

UNIVERSITY OF ZAGREB FACULTY OF AGRICULTURE  
AGRICULTURAL ENGINEERING DEPARTMENT  
UNIVERSITY OF J. J. STROSSMAYER IN OSIJEK  
FACULTY OF AGROBIOTECHNICAL SCIENCES  
UNIVERSITY OF MARIBOR  
FACULTY OF AGRICULTURE AND LIFE SCIENCES  
AGRICULTURAL INSTITUTE OF SLOVENIA, LJUBLJANA  
INSTITUTE OF AGRICULTURAL ENGINEERING, BOKU, VIENNA  
NATIONAL INSTITUTE FOR AGRICULTURAL MACHINERY,  
INMA BUCHAREST  
CROATIAN AGRICULTURAL ENGINEERING SOCIETY



PROCEEDINGS OF THE 49<sup>th</sup> INTERNATIONAL SYMPOSIUM

# ACTUAL TASKS ON AGRICULTURAL ENGINEERING

OPATIJA, CROATIA, FEBRUARY 28<sup>th</sup> - MARCH 2<sup>nd</sup> 2023



UNIVERSITY OF ZAGREB FACULTY OF AGRICULTURE  
AGRICULTURAL ENGINEERING DEPARTMENT

UNIVERSITY OF J. J. STROSSMAYER IN OSIJEK  
FACULTY OF AGROBIOTECHNICAL SCIENCES

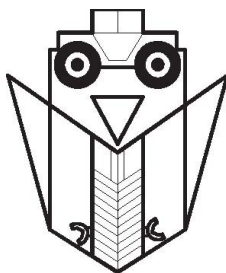
UNIVERSITY OF MARIBOR  
FACULTY OF AGRICULTURE AND LIFE SCIENCES  
AGRICULTURAL INSTITUTE OF SLOVENIA, LJUBLJANA  
INSTITUTE OF AGRICULTURAL ENGINEERING, BOKU,  
VIENNA

NATIONAL INSTITUTE FOR AGRICULTURAL MACHINERY,  
INMA BUCHAREST

CROATIAN AGRICULTURAL ENGINEERING SOCIETY



# ACTUAL TASKS ON AGRICULTURAL ENGINEERING



PROCEEDINGS

of the 49<sup>th</sup> International Symposium

Opatija, Croatia, 28<sup>th</sup> February – 2<sup>nd</sup> March 2023

---

Published by University of Zagreb, Faculty of Agriculture  
Department of Agricultural Engineering,  
Svetošimunska 25, 10000 Zagreb, Croatia

---

Editors Igor Kovačev (ikovacev@agr.hr)  
Mateja Grubor (mgrubor@agr.hr)

Technical editor Igor Kovačev

---

Organising committee

Anamarija Banaj	Mateja Grubor
Nikola Bilandžija	Dubravko Filipović
Krešimir Čopec	Igor Kovačev, Chairman
Goran Fabijanić	Stjepan Sito

---

Scientific committee

Assoc. prof. dr. Nikola Bilandžija, HR, Chairman	Prof. dr. Dumitru Mnerie, RO
Ing. Jaroslav Čepl, CSc., CZ	Prof. dr. Joachim Mueller, DE
Prof. dr. Aleksandra Dimitrijević, RS	Prof. dr. Pietro Picuno, IT
Assoc. prof. dr. Đorđe Đatkov, RS	Prof. dr. Stjepan Pliestić, HR
Prof. dr. Dubravko Filipović	Prof. dr. Egidijus Sarauskis, LT
Prof. dr. Ettore Gasparetto, IT	Prof. dr. John Schueller, USA
Prof.dr. Ivo Grgić, HR	Prof. dr. Peter Schulze-Lammers, DE
Prof. dr. Andreas Gronauer, AT	Prof. dr. Denis Stajnko, SI
Dr. Viktor Jejčič, SI	Prof. dr. Dumitru Tucu, RO
Prof. dr. Silvio Košutić, HR	Assoc. prof. dr. Vjekoslav Tadić, HR
Assoc. prof. dr. Igor Kovačev, HR	Assist. prof. dr. Peter Vindiš, SI
Prof. dr. Miran Lakota, SI	Dr. Valentin Vladut, RO
Prof. dr. Milan Martinov, RS	Prof. dr. Daniele De Wrachien, IT

**ISSN 1848-4425**

**<http://atae.agr.hr>**

Cover photo: Lanz Bulldog at the entrance to the Agricultural Engineering Department test site, oil on canvas by Dušan Jejčič

All papers in the Proceedings are peer reviewed.

Papers from the Proceedings have been indexed since 1997 into databases:

Clarivate Analytics: Web of Science Core Collection: Conference Proceedings Citation Index  
CAB International: Agricultural Engineering Abstracts

---

---

## SPONSORS



**POLJO-NOVA d.o.o. – SESVETE**



**POLJOOPSKRBA MT – ZAGREB**



**MESSIS – ZAGREB**



**AGROMEHANIKA – BJELOVAR**

---

## PREFACE

Dear colleagues,  
Dear readers,

I am very pleased to introduce the Proceedings of the 49th edition of Actual Tasks on Agricultural Engineering, with its unique and long tradition. Due to the worldwide Corona pandemic and last online symposium, this year's symposium is gathering us again in person in our beautiful Opatija from February 28 to March 2, 2023.

For the quality of the content of the Proceedings, the authors of 54 papers from 10 countries are meritorious, including: Austria 1, Croatia 11, Czech Republic 1, Germany 1, Hungary 1, Italy 3, Lithuania 5, Romania 20, Serbia 5, and Slovenia 6.

International professional associations as co-organizers of this year's Symposium are Croatian Soil Tillage Research Organization (CROSTRO (HDPOT)) International Commission of Agricultural and Biosystems Engineering (CIGR), and European Network for Advanced Engineering in Agriculture and Environment (EurAgEng).

The scientific importance of the ATAE symposium is assessed by the fact that papers from the Proceedings have been indexed since 1997 into databases: Clarivate Analytics: Web of Science Core Collection - Conference Proceedings Citation Index and CAB International - Agricultural Engineering Abstracts. Access to the web edition of the Proceedings is free of charge at the website <https://atae.agr.hr/proceedings.htm>.

I would like to thank all authors, reviewers and especially the members of the Organizing and Scientific Committees for their efforts in making this conference possible.

It is my pleasant duty to acknowledge the financial support from the POLJO-NOVA d.o.o.

I hope that at the next ATAE symposium in 2025, we will gather again in person and make a toast with a glass of wine for our 50th anniversary of ATAE symposium.

Zagreb, March 2023

Mateja Grubor, editor

---

## CONTENTS

<b>Anamarija BANAJ, Đuro BANAJ, Bojan STIPEŠEVIĆ, Dominik MIKOLČEVIĆ</b> .....	11
Application of the newly designed seed eliminator for the vacuum sowing machine	
<b>Giovanni CARABIN, Lorenzo BECCE, Andreas MANDLER, Fabrizio MAZZETTO</b> .....	23
Integrated determination of tractor centre of gravity and lateral rollover angle	
<b>Fredrik REGLER, Max KRUEGER, Heinz BERNHARDT</b> .....	33
Using a digital maintenance assistant to independently maintain the PTO shaft	
<b>Zita KRIAUČIŪNIENĖ, Lina SALDUKAITĖ, Sidona BURAGIENĖ, Aida ADAMAVIČIENĖ, Andrii ZABRODSKYI, Egidijus ŠARAUSKIS</b> .....	41
Effect of strip tillage and direct seeding on winter wheat yield, diesel consumption and environment	
<b>Nicolae LONTIS, Gabriel MALAIMARE, Dumitru TUCU</b> .....	51
Stability analysis of a trailed farm sprayer aggregate by simulation model	
<b>Lorenzo BECCE, Giovanni CARABIN, Fabrizio MAZZETTO</b> .....	59
Evaluation of air flow influence on sprayer nozzle performance by shadowgraphy	
<b>Jurica PLUKAVEC, Dubravko FILIPOVIĆ, Igor ĐUKIĆ, Krešimir ČOPEC, Igor KOVAČEV</b> .....	69
Analysis and comparison of the noise of hand-held and back-pack type grass trimmers	
<b>George IPATE, Cristian CIOBANU, Gheorghe VOICU, Filip ILIE, Madalina STEFAN, Paula TUDOR, Iuliana GAGEANU, Petru CARDEI, Dan CUJBESCU</b> .....	79
Estimation of the parameters of the portland cement clinker grinding equation in the ball mill	
<b>Kęstutis ROMANECKAS, Jovita BALANDAITĖ, Austėja ŠVEREIKAITĖ, Algirdas JASINSKAS, Ugnius GINELEVIČIUS, Deividas PAKALNIS</b> .....	91
Impact of maize, hemp and faba bean intercropping on the soil properties	
<b>Egidijus ŠARAUSKIS, Marius KAZLAUSKAS, Indrė BRUČIENĖ, Kęstutis ROMANECKAS, Vilma NAUJOKIENĖ, Sidona BURAGIENĖ, Dainius STEPONAVIČIUS, Abdul Mounem MOUAZEN</b> .....	99
Winter wheat productivity and profitability at variable seeding rate and depth	

---

<b>Jaroslav ČEPL, Pavel KASAL, Andrea SVOBODOVA.....</b>	<b>109</b>
Influence of potato weed management on yield and quality of potato	
<b>Zorica SRĐEVIĆ, Bojan SRĐEVIĆ, Senka ŽDERO, Milica ILIĆ, Laslo GALAMBOŠ, Tanja BOŠNJAK.....</b>	<b>119</b>
Reducing drought risks in wetlands: analysis of causality relations between regulating measures using DEMATEL	
<b>Bojan SRĐJEVIC, Zorica SRĐJEVIC .....</b>	<b>129</b>
Multicriteria and social choice methods in agriculture, water management and forestry	
<b>Vlad MĀRĀZAN, Alexandru ŢUCU, Hortensia RĀDULESCU, Rareş HĀLBAC-COTOARĀ-ZAMFIR .....</b>	<b>141</b>
Squall phenomena in the Banat-Crişana plain of Romania and their impact on agriculture in a changing climate	
<b>Vlad MĀRĀZAN, Codruţa CHIŞ, Antoanela COZMA, Rareş HĀLBAC-COTOARĀ-ZAMFIR .....</b>	<b>151</b>
Quantitative analysis of precipitation and the liaison with agriculture in western Romania	
<b>Antoanela COZMA, Ariana VELCIOV, Iasmina Madalina ANGHEL, Bogdan COZMA, Vlad MĀRĀZAN.....</b>	<b>161</b>
Development of chicken eggshells powder as agricultural fertilizer and soil conditioner	
<b>Vladimir PEJAKOVIĆ, Andreas GRONAUER .....</b>	<b>173</b>
Agricultural robots for the field operations	
<b>Larisa Georgiana MATEI, Andrei-Alin VOINESCU, Alexandru SUCIU, Narcis GHITA, Marius FATU, Gabriel GARBAN, Titus SLAVICI.....</b>	<b>183</b>
New system of manufacturing molds using Industry 4.0 for pellets and briquettes	
<b>Ivan BRANDIĆ, Neven VOĆA, Josip LETO, Nikola BILANDŽIJA.....</b>	<b>193</b>
Application of machine learning models in miscanthus x giganteus yield estimation	
<b>Ante GALIĆ, Stjepan PLIESTIĆ .....</b>	<b>203</b>
Technological innovations and new approaches in agricultural production	
<b>Dumitru TUCU, Gabriel MALAIMARE, Vasile LEŞ, Nicolae LONTIS.....</b>	<b>213</b>
Performance evaluation of photovoltaic system in conditions of independent farm	
<b>Ariana-Bianca VELCIOV, Iasmina Madalina ANGHEL, Maria RADA, Vlad MĀRĀZAN, Antoanela COZMA.....</b>	<b>223</b>
Valorification of the nettle plants from spontaneous flora as nettle powder – mineralizing potential in animal feed	
<b>Vjekoslav TADIĆ, Davor PETROVIĆ, Petra MIŠKULIN, Goran PAČAREK, Ivan VIDAKOVIĆ, Željko BARAČ .....</b>	<b>233</b>
Protection systems against late spring frosts in permanent crops	

---

<b>Cătălina TUDORA, Cristina STROE, Floarea BURNICHI, Adriana MUSCALU, Valentin Nicolae VLĂDUȚ</b> .....	245
Interactive, modulated system for the protection of vegetable crops	
<b>Peter BERK, Andreja URBANEK KRAJNC, Mario LEŠNIK, Andrej PAUŠIČ, Denis STAJNKO, Peter VINDIŠ, Damijan KELC, Miran LAKOTA, Aleš BELŠAK, Tomaž POJE, Viktor JEJČIČ, Mojca MAVRIČ ŠTRUKELJ, Simona HAUPTMAN, Marko BREZNIK, Marko HOČEVAR, Matej SEČNIK</b> .....	255
Automated spray mixture application process in the "Rebula" variety vineyard	
<b>Damijan KELC, Denis STAJNKO, Miran LAKOTA, Peter VINDIŠ, Jurij RAKUN, Erik RIHTER, Peter BERK</b> .....	267
Efficiency of alternative weed control with mechanical systems in the vineyard	
<b>Erik RIHTER, Damijan KELC, Denis STAJNKO, Rajko BERNIK, Peter VINDIŠ, Vasilije FEMIĆ, Peter LEPEJ, Miran LAKOTA, Jurij RAKUN</b> .....	275
An approach to save on plant protection products in cherry orchards	
<b>Denis STAJNKO, Peter BERK, Damijan KELC, Miran LAKOTA, Jurij RAKUN</b> .....	285
The effect of different led lighting on the growth of Eruca sativa (Mill.)	
<b>Emilia DOBRIN, Nicușor-Alin SÎRBU, Gabriela-Victoria MNERIE</b> .....	293
Research on the ultrasonic extraction of volatile sea buckthorn oils	
<b>Matija BALALA, Igor KOVAČEV, Lepomir ČOGA, Sanja SLUNJSKI, Fabio CELLA, Željko JUKIĆ</b> .....	303
Influence of nitrogen fertilization on the rupture force of maize kernels	
<b>Augustina PRUTEANU, Mihaela NITU, Cristian SORICA</b> .....	315
Research on the analysis of fruit and vegetable juice yield	
<b>Mateja GRUBOR, Nikola BILANDŽIJA, Ana MATIN, Vanja JURIŠIĆ, Darija BILANDŽIJA, Tajana KRIČKA</b> .....	325
The influence of precipitation on the energy properties of wheat biomass	
<b>Božidar MATIN, Tajana KRIČKA, Alen ĐUROVIĆ, Mateja GRUBOR, Ana MATIN, Alan ANTONOVIĆ</b> .....	331
Lignocellulosic composition and heating value of forest and agricultural biomass: A review	
<b>Gvidas GRAMAUSKAS, Algirdas JASINSKAS, Ramūnas MIELDAŽYS</b> .....	343
Evaluation of the processing and utilization of invasive herbaceous plants for the production of biofuel pellets	
<b>Aleksandar NESTEROVIC, Djordje DJATKOV, Miodrag VISKOVIĆ, Milan MARTINOV</b> .....	353
Sustainable crop residues potential for the production of lignocellulosic bioethanol in Serbia	

---



---

<b>Zorana KOVAČEVIĆ, Anja ZERGOLLERN, Ksenija VIŠIĆ.....</b>	<b>363</b>
Analysis of fibres extracted from corn husk	
<b>Algirdas JASINSKAS, Rita PETLICKAITĖ, Edvardas VAICIUKEVIČIUS, Kęstutis ROMANECKAS .....</b>	<b>371</b>
Processing and utilization of large-stemmed herbaceous plants for energy conversion	
<b>Anamarija GUDELJ-VELAGA, Nikola BILANDŽIJA, Mateja GRUBOR, Ivana TOMIĆ, Zorana KOVAČEVIĆ, Tajana KRIČKA.....</b>	<b>381</b>
Enzymes for lignocellulosic biomass degradation as an approach to green technology	
<b>Viktor JEJČIČ, Tomaž POJE, Fouad AL-MANSOUR.....</b>	<b>389</b>
Energy consumption for production rapeseed oil on family farms	
<b>Cristian BEJERITA, Adriana-Carmen CAZAN, Nicoleta CONDESCU-ULARU, Liliana DORNEANU, Cristian COSARIU, Simina MARIS.....</b>	<b>399</b>
Statistical methods and artificial neural networks in the optimization of heating pellets and briquettes	
<b>Adriana-Carmen CAZAN, Cristian BEJERITA, Alexandra SUTA, Andrei-Alin VOINESCU, Larisa Georgiana MATEI, Simina MARIS, Daniel BOTEZ, Titus SLAVICI.....</b>	<b>409</b>
Contemporary manufacturing techniques used in agricultural engineering	
<b>László MAGÓ .....</b>	<b>419</b>
Farmers cooperation in procurement and distribution of goods using online-marketplace	
<b>Bogdan Raul MIRCEA, Rudolf MIRESCU, Dumitru TUCU .....</b>	<b>427</b>
The use of gauge R&R method in manufacturing of agricultural machinery	
<b>Djordje DJATKOV, Aleksandar NESTEROVIC, Miodrag VISKOVIC, Milan MARTINOV .....</b>	<b>437</b>
Small biogas plants in Serbia- prerequisites for profitability	
<b>Miodrag VISKOVIC, Djordje DJATKOV, Aleksandar NESTEROVIC, Milan MARTINOV .....</b>	<b>447</b>
Possibilities for financing of new biogas plants in Serbia	
<b>Rudolf MIRESCU, Alexandru TUCU, George Catalin CRISAN, Emil KAZOMIR, Dumitru TUCU.....</b>	<b>457</b>
Causes and consequences of work events in the food industry enterprises from Timis county	
<b>Rudolf MIRESCU, Alexandru TUCU, Bogdan Raul MIRCEA, Dumitru TUCU.....</b>	<b>467</b>
Occupational risk management by systems ergonomics in manufacturing of ice cream sticks	

---

---

<b>Alexandru TUCU, Anca-Alexandra PURCĂREA, George Catalin CRISAN, Vlad MĂRĂZAN, Dumitru TUCU</b> .....	<b>473</b>
Perception of control in motivating compliance with ohs requirements in rural SMEs	
<b>Emil Călin KAZOMIR, Dumitru ȚUCU</b> .....	<b>481</b>
Safety improvement of integrated biomass combustion systems by simulation	
<b>Ramona DZITAC, Ileana MOGOȘANU, Simina-Ștefania MARIȘ, Gabriela-Victoria MNERIE, Mihaela POPUȚA</b> .....	<b>489</b>
Some particularities of telework activities practiced in agriculture	
<b>Tomaž POJE</b> .....	<b>499</b>
Analysis of registered tractors in Slovenia in the year 2021	
<b>Gheorghe VOICU, Mircea-Bucur LAZEA, Paula TUDOR, Gabriel-Alexandru CONSTANTIN, Bianca-Stefania ZABAVA</b> .....	<b>507</b>
Plastic waste behaviour during compaction in horizontal press with continuous feeding	
<b>Pietro PICUNO, Roberto PUGLISI, George SPYROU, Evangelos DIMITRIOU, George PAPADAKIS, Maria SMYRNIOTAKI, Violetta OUTSOGIANNNOPOULOU, Christine STAVROPOULOU, Tina PAPASIDERI, Mercè BALCELLS, Lluís MARTIN CLOSAS, Luca BRONDELLI DI BRONDELLO, Cristina MATA, Anna FARRUS, Fátima BAPTISTA, Vasco FITAS DA CRUZ, Maria Elena MUR CACUHO, Teresa BATISTA, Firmino CORDEIRO, Zoe GODOSI, Delphine MARGOUT-JANTAC</b> .....	<b>517</b>
Training farmers on circular economy implementation: The TANGO-circular project	
<b>Nikola BILANDŽIJA, Andrea PUŠKARIĆ, Neven VOĆA, Vanja JURISČIĆ, Jona ŠURIĆ, Anamarija PETER</b> .....	<b>527</b>
The energy potential of the brewers' spent grain in small craft breweries – case study “Zmajška pivovara”	
<b>Commercial pages</b> .....	<b>535</b>



## APPLICATION OF THE NEWLY DESIGNED SEED ELIMINATOR FOR THE VACUUM SOWING MACHINE

Anamarija BANAJ<sup>1\*</sup>, Đuro BANAJ<sup>1</sup>, Bojan STIPEŠEVIĆ<sup>1</sup>, Dominik MIKOLČEVIĆ<sup>2</sup>

\*E-mail of corresponding author: abanaj@fazos.hr

<sup>1</sup>Faculty of Agrobiotechnical Sciences Osijek, Josip Juraj Strossmayer University of Osijek

<sup>2</sup>PhD student at Faculty of Agrobiotechnical Sciences Osijek, Josip Juraj Strossmayer University of Osijek

### ABSTRACT

*The paper presents the comparative results of the research on the application of the newly developed and original seed eliminator when sowing 4 fractions of corn. The research was conducted at the Department of Agricultural Engineering and Renewable Energy Resources of the Faculty of Agrobiotechnical Sciences Osijek. The newly developed seed eliminator covers a section of a circle of 10° more and is extended with one field with small teeth. The research was carried out on a test table at a simulation speed of 6 km h<sup>-1</sup>. The original seed eliminator in position "19" when sowing the LFG fraction achieved the best QFI index of 98.81 with an average distance of 21.070 cm, and the new seed eliminator in position "20" achieved a QFI index of 99.69, a Mult index of 0.19 and a Miss index of only 0.13. During the simulation of sowing with the original seed eliminator of the MRG fraction, a QFI index of 99.38 was determined, as well as a Mult index of 0.13 and a Miss index of 0.50, with the use of the new seed eliminator, a deviation from the theoretical distance of only -0.002 cm was recorded with the high value of QFI index of 99.69. When sowing the LFG fraction when using the original seed eliminator at position "19", the QFI index value of 99.13 was obtained. The new seed eliminator obtained value of QFI index of 99.44 with a Mult index of 0.31 and a Miss index of 0.25. Even with the sowing of the LFG fraction, a significant improvement in sowing quality is visible with the use of the new seed eliminator. The best result of sowing the LRG fraction with the original seed eliminator was achieved at position "22", where the average sowing distance of 21.055 + 0.062 cm was achieved compared to the theoretical distance of 20.993 cm. In this position, the seed eliminator achieved a QFI index of 99.68 with a Miss index of 0.31. Similar results were achieved using the new seed eliminator, which achieved a slightly better Prec.index of only 7.193.*

**Keywords:** sowing, vacuum sowing machine, seed eliminator, grain fraction, QFI index

## INTRODUCTION

The importance of preparing and adjusting the Sowing machine before sowing in nowadays production conditions is one of the most important factors in the overall production of corn (Staggenborg, S.A. et al., 2004.). Attention should be paid to the seed extraction system, which must be adapted for sowing certain sizes (small, medium and large) and seed shapes (flat or round). (Banaj, A et al., 2021a.) The vacuum system is based on the creation of vacuum at the openings of the seed plate so that the seeds (one or more) in the lower part of the chamber adhere to the opening of the plate. By rotating the sowing plate, the seeds come into a space where there is no negative pressure and under the influence of gravity they fall into the furrow opened by a coulter or a disc feeder. The importance of adjustment according to Lauer, J. (2001); Banaj, A. et al. (2017a.) is based on the fact that at the time of harvest, 7 to 12 % of the plants of the planned theoretical set are missing. Berus, P. (2010.) states that the sowing machine is optimally adjusted if it provides 95 % sowing. This information can be reliable for the realization of the plant population, but it also hides double ejected seeds, which we cannot determine with this percentage (Banaj, A. et al. 2021.). Another indicator of sowing precision is the determination of the percentage of double grains and empty places (unsown grains) within a row. If the number of double grains and empty places is less than 2.5 %, the planter is considered to be very precise. If the percentage of the specified values is  $> 5$  %, the Sowing machine must be readjusted or worn parts must be replaced. Önal, I. (2006.) states and recommends an upper limit of 4.75 %. After selecting the hybrid and adjusting the transmission ratio ( $i$ ), it is necessary to adjust the seed eliminator with regard to the shape and size of the grain. An adjusted seed eliminator with regard to the shape of the grain ensures quality sowing, otherwise there will be an empty space inside the row without seed or an accumulation of seeds (2-3 grains) at the same sowing place, which prevents optimal growth and development of plants due to the lack of vegetation space. The main role of the seed eliminator is to direct the one or more attracted seeds on the hole of the rotating seed plate towards the central part of the hole, where the level of vacuum is also the highest. If the seed eliminator is moved with its teeth closer to the sowing hole of the plate, it is also possible to remove one seed from the hole of the seed plate. By moving the seed eliminator to the opposite side, we will enable the sowing of double or more seeds. Findura, P. et al. (2012.) states that, among other things, the size and shape of the seed is also important. Yazgi, A. et al. (2016.) investigated the physical properties of seeds as they affect variables such as the level of vacuum, peripheral speed and the diameter of the vacuum plate hole. The authors state that the physical properties of the seed plays an important role in choosing the appropriate diameter of the hole of the seed plate and the level of vacuum. The speed of the sowing machine at the time of sowing should be increased to the level that the quality of work is not impaired (Banaj, Đ. & Šmrčković, P., 2002.). When simulating sowing in laboratory conditions at working speeds of 4 and 8 km h<sup>-1</sup>, Vitas, N. et al. (1990.) state that regardless of the equal distance of the holes on the seed plate, the seeds are not distributed at the same distance from each other. The reason is in because the seed is not forcibly guided, but upon reaching the area of atmospheric pressure, falls at different speeds depending on its own mass and the moment of separation from the seed plate. Unfavorable spacing distribution as well as an increased number of ejected double grains and unfilled holes were obtained at a

simulation speed of  $8 \text{ km h}^{-1}$ . Karayel, D. et al. (2004.) state that with a mathematical model for prediction based on absolute mass, sphericity, they determined that the optimal value of negative pressure for corn kernels of absolute mass  $288.7 \pm 1.90$  and  $372.50 \pm 2.10$  g of 4.0 kPa and 3.0 kPa for cotton, soybean and watermelon. Yazgi, A. et al. (2010.) conclude that the performance of the seeding system is affected by the hole diameter of the seed plate. The optimal hole diameter would be about 3.8 mm and can vary depending on the size and shape of the seeds. The vacuum level is also important and interacts with the hole diameter. The optimal level would be 7.7 kPa, but it also depends on the physical properties of the maize seed. The authors state that the optimal rotational speed of the vacuum plate for maize seed is  $0.07 \text{ m s}^{-1}$  ( $0.7 \text{ m s}^{-1}$  working speed), but at such speed, a small area would be seeded in a unit of time. Therefore, the authors suggest increasing the speed to  $0.15 \text{ m s}^{-1}$  ( $1.5 \text{ m s}^{-1}$  working speed) although increasing the speed decreases the QFI index. Onal, I. et al. (2012.) state that  $16 \text{ seeds s}^{-1}$  is the upper limit of the seed eliminator frequency (SRF) for cotton and corn seeds, that is, the upper acceptable peripheral speed of the vacuum plate is  $0.34 \text{ m s}^{-1}$ . Likewise, the authors state that vacuum plates with  $n=26$  holes are suitable for sowing corn seeds.

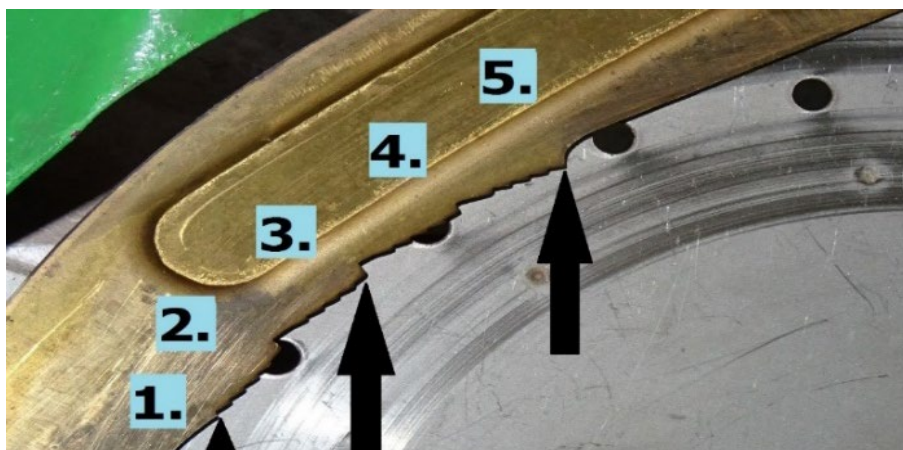
## MATERIALS AND METHODS

The research was conducted at the Department of Agricultural Engineering and Renewable Energy resources of the Faculty of Agrobiotechnical Sciences Osijek. A PSK pneumatic sowing machine from the OLT Osijek company was placed on the test table for simulating corn sowing with the possibility of adjusting certain technical sowing factors. By setting the number of revolutions of the fan shaft to  $4.320 \text{ min}^{-1}$  in the same sowing machine with filled sowing plates,  $n=22$  holes  $\varnothing 5.5$  mm, a vacuum of 4.58 kPa was achieved. Determining the most favorable position of the seed eliminator was carried out at different distances of the teeth of the seed eliminator in relation to the central diameter of the hole of the vacuum plate at the working speed of the simulation of  $6 \text{ km h}^{-1}$ . In the research, two seeds eliminator were used: the original one (Figure 1), which has 5 tips or 4 areas with small teeth.



**Figure 1** Original seed eliminator (down) and new seed eliminator (up)

This eliminator covers the space of  $36^\circ$  of the seed plate. On the new seed eliminator, another area with small teeth has been added, and there are a total of 5 areas or 6 tips. The new seed eliminator covers the surface of the seed plate by  $49^\circ$  or  $10^\circ$  more than the original seed eliminator. Seed eliminators are made of stainless steel AISI 304 and cut with the Amada LC 3015 XI NT device.



**Figure 2** Position of the seed eliminator at the PSK sowing machine

**Table 1** Distance of the tooth tip of the seed eliminator from the center of the vacuum plate hole ( $\varnothing$  5.5 mm) in mm

Measuring point - number of teeth	Mark on the scale				
	0	10	20	25	30
1	2.00	2.50	3.00	3.50	4.00
3	0.50	1.25	2.25	2.75	3.00
5	-0.50	0.00	1.75	2.00	2.50

The simulation of sowing with the mentioned eliminators was carried out at a theoretical distance of 22.993 cm with the dynamic diameter of the driving wheel of the sowing machine  $D_d=62.10$  cm, and the other factors of the test simulation are shown in Table 2.

The spacings were determined with the help of a sensor for detecting the time of seed passage, whereby the central unit calculates the seeding spacings with the simulated working speed. The position of the sowing machine was determined by an encoder 1200 with an error in measuring the distance traveled of  $\pm 1.37$  mm, where a very high position accuracy was achieved, and it was mounted on the drive shaft of the sowing machine.

Measurements of the basic properties of the thickness, width and length of the grains of the seeds used by the fractions of the tested hybrids were carried out with a movable digital scale of the company INSIZE CO., LTD, with 200 randomly selected grains.

**Table 2** Technical factors during measurements at the tested vacuum plates

Technical factors	Vacuum plate 22 (hole ø 5,5 mm)
Drive wheel to vacuum plate ratio (i)	0.42221
Working speed (m s <sup>-1</sup> )	1.666
Peripheral speed (m s <sup>-1</sup> )	0.359
Seed releasing frequency (s)	7.898
Distance between 2 holes (mm)	21.631
Theoretical spacing (cm)	20.993



**Figure 3** Shape of hybrid seed fraction used in research (large round grain-left, large flat grain-right)



**Figure 4** Shape of hybrid seed fraction used in research (medium round grain-left, medium flat grain-right)

Measurements of the basic characteristics of the thickness, width and length of the seeds used fractions are shown in Table 3.

Table 3 Average grain dimensions by fractions

Fraction	Grain dimensions, $\bar{x}$			Grain properties, $\bar{x}$		
	Thickness (mm)	Width (mm)	Length (mm)	Absolute mass (g)	Hectolitre mass (kg)	Moisture (%)
<b>LRG</b>	6.83	8.80	9.79	374.25	66.18	9.95
<b>MRG</b>	6.79	8.24	9.67	318.50	69.87	10.08
<b>LFG</b>	4.90	8.63	10.70	318.53	70.45	10.55
<b>MFG</b>	5.16	8.16	10.40	287.11	69.95	12.55

LRG-large round grain; MRG-medium round grain; LFG-large flat grain; MFG-medium flat grain

From Table 3, it can be seen that the grains of the LRG fraction had the highest average absolute mass of 374.25 g with an average hectoliter mass of 66.18 kg at a moisture content of 9.95 %. Among the mentioned fractions, the largest average hectoliter weight (70.45 kg) was obtained from the LFG fraction determined at a moisture content of 10.55 %. Most of the research was carried out according to the ISO standard: ISO 7256-1:1984 for single seed drills - standard sowing (Sowing equipment - Test methods - Part 1: Single seed drills). The comparison of the precision of the work during the simulation is based on the evaluation of the uniformity of sowing using the QFI, MULT and MISS indices. The ISO standard classifies spacing determination into three different seed spacing groups according to the theoretical spacing ( $Z_t$ ):

I. The multiple index MULT ( $I_{mt}$ ) indicates the percentage of multiple seed drops ( $N_{mt}$ ) (0 to  $\leq 0.5 Z_t$ ),  $Z_t$  is the theoretical seed spacing:

$$I_{mt} = \frac{N_{mt}}{N} 100 \quad (1)$$

II. Quality of feed index (QFI) indicates the percentages of single seed drops in the range of  $>0.5 Z_t$  to  $\leq 1.5 Z_t$ ;

III. Missing index, The miss index ( $I_{ms}$ ) is the ratio of number of spacing ( $N_{ms}$ ) greater than 1.5 times of set spacing and total number of measured spacings ( $N$ ):

$$I_{ms} = \frac{N_{ms}}{N} 100 \quad (2)$$

Seed spacing uniformity of the main seed distribution (QFI), called precision (Prec. index), is expressed by the coefficient of variation ( $CV_m$ , %) as shown in equation:

$$CV_m = \frac{\sigma}{z_m} 100 \quad (3)$$

Where  $\sigma$  is the standard deviation of the main seed distribution (QFI) and  $Z_m$  is the mean seed spacing of the main seed distribution curve.



## RESULTS AND DISCUSSION

### *Results of measurement of vacuum values at holes of seed plates*

The vacuum, which is created by the rotation of the fan, must adhere to the seeds at the hole of the vacuum plate, opposing the force of gravity and the forces created by the rotation of the plate as a consequence of the rotational speed Zimmer et al. (2009.) It can be said that the vacuum opposes the weight and friction of the seeds, and the centrifugal force.

**Table 4** Air velocities at different distances from the center of a hole

Vacuum pressure (kPa)	Terminal velocity (m s <sup>-1</sup> )	Distances from the center of a hole ø 5.5 mm (mm)				
		0	2.75	7.75	12.75	18.27*
Air velocity (V <sub>ri</sub> ) m s <sup>-1</sup>						
4.58	8.32–12.41	62.838	31.350	3.947	1.458	0.710

\*The center between two holes on the sowing plate n=22

### *Results of measuring the most favorable position of the seed eliminator*

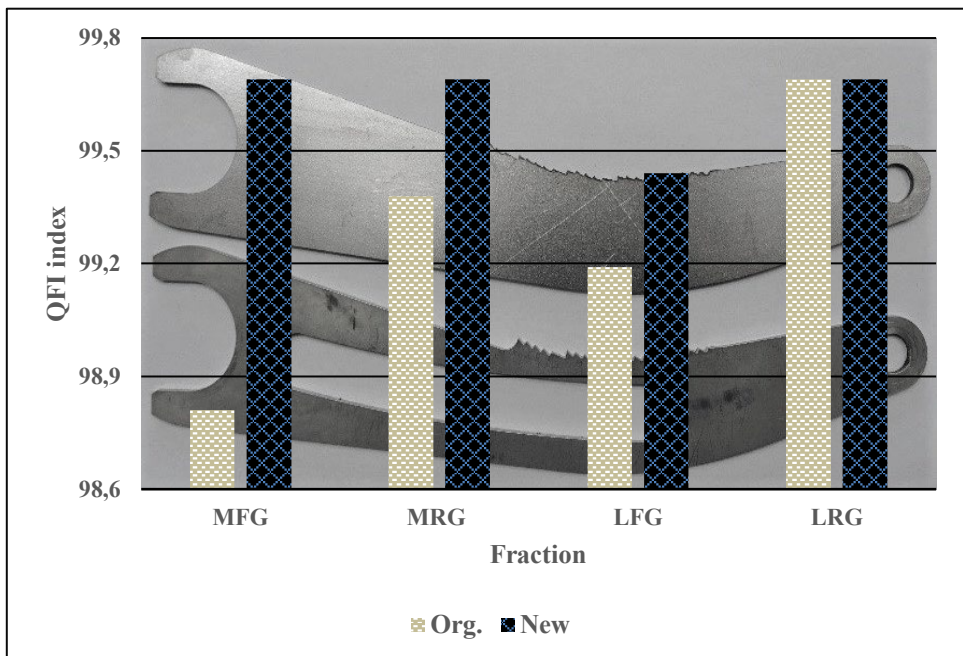
From Table 5, it can be seen that the original seed eliminator in position "19" when sowing the LFG fraction achieved the best QFI index of 98.81 with an average spacing of 21,070 cm. The obtained average distance is larger than the theoretical one by +0.077 cm. However, using the new seed eliminator at the "20" position, a QFI index of 99.69 and a Mult index of 0.19 and a Miss index of only 0.13 were achieved. With this fraction, it can be seen that by using the new seed eliminator, it was achieved a slightly better result in sowing, and this was confirmed at a highly significant level (P<0.01). When simulating the sowing of the MRG fraction when using the original seed eliminator at position "24", an average distance of 21.058 cm was achieved with a deviation of +0.065 cm. The analysis of the obtained spaces revealed a QFI index of 99.38, a Mult index of 0.13 and a Miss index of 0.50. It was also established Prec. index of 8.034. According to the authors Banaj et. al. (2021) achieved the smallest average deviations during seeding simulation using KP and KO seed fractions at the seed eliminator position at factory mark 10 (KP -0.0 7% and KO -0.32) at the working speed of the sowing machine of 8 km h<sup>-1</sup> (%), and with the fraction SO and SP, they achieved the best average result at the position of the seed eliminator at position 25 (SO + 0.44 % and SP + 0.39 %). An analysis of the distances achieved when using the new seed eliminator in position "22" revealed a deviation from the theoretical distance of only -0.002 cm. The new seed eliminator achieved a high QFI index of 99.69, a Mult index of 0.19 and a Miss index of 0.13. By analyzing the data, the new seed eliminator achieved the lowest Prec. index of only 7.127. Based on the above, it can be seen that the new seed eliminator achieved better results at a simulation speed of 6 km h<sup>-1</sup>. When sowing the LFG fraction using the original seed eliminator at position "19", the value of the QFI index was 99.13 and the Mult index was obtained of 0.19 and Miss index of 0.63. Testing resulted in an average distance of 21.086 cm, i.e. more by + 0.093 cm compared to the theoretical distance. However, using the new seed eliminator, an average seeding distance of 20.982 cm was achieved with a QFI index of 99.44, a Mult index of 0.31 and a Miss index of 0.25.

**Table 5** Statistical measurement values and sowing quality indices

Fraction/ org or new/ mark on the scale	Statistical measurement values				Sowing quality indices			
	$\bar{x}$	$\sigma$	C.V. (%)	T- $\bar{x}$ (cm)	Mult index	Qfi index	Miss index	Prec. indeks (C.V.)
MFG /Org./18	21.281	0.234	1.10	+ 0.288	0.13	98.38	1.50	9.125
MFG /Org./19	21.070	0.132	0.63	+ 0.077	0.50	98.81	0.69	9.540
MFG /Org./20	20.924	0.108	0.51	- 0.069	0.88	98.56	0.56	9.052
MFG /New/19	21.371	0.201	0.941	+ 0.378	0.06	98.06	1.88	8.181
MFG /New/20	20.982	0.050	0.239	- 0.011	0.19	99.69	0.13	8.530
MFG /New/21	20.898	0.024	0.116	- 0.095	0.63	99.13	0.25	9.106
MRG /Org./20	21.308	0.183	0.861	+ 0.315	0.00	98.56	1.44	7.309
MRG /Org./22	21.161	0.139	0.655	+ 0.168	0.13	98.94	0.94	7.708
MRG /Org./24	21.058	0.185	0.878	+ 0.065	0.13	99.38	0.50	8.034
MRG /New/20	21.174	0.069	0.328	+ 0.181	0.06	99.06	0.88	7.733
MRG /New/22	20.991	0.049	0.232	- 0.002	0.19	99.69	0.13	7.127
MRG /New/24	20.939	0.111	0.529	- 0.054	0.56	99.19	0.25	7.689
LFG/Org./19	21.086	0.086	0.407	+ 0.093	0.19	99.19	0.63	8.280
LFG/Org./21	20.915	0.110	0.525	- 0.078	0.63	99.13	0.25	8.643
LFG/Org./23	20.899	0.028	0.132	- 0.094	0.69	99.00	0.31	8.783
LFG/New/20	20.914	0.056	0.270	- 0.079	0.56	99.31	0.13	8.455
LFG/New/21,5	20.982	0.088	0.421	- 0.011	0.31	99.44	0.25	8.453
LFG/New/23	20.902	0.102	0.490	- 0.091	0.75	98.88	0.38	9.318
LRG/Org./20	21.094	0.081	0.386	+ 0.101	0.06	99.44	0.50	7.513
LRG/Org./21	21.058	0.026	0.124	+ 0.065	0.00	99.69	0.31	7.218
LRG/Org./22	21.055	0.052	0.247	+ 0.062	0.00	99.69	0.31	7.987
LRG/New/20	21.242	0.134	0.632	+ 0.249	0.13	98.63	1.25	7.307
LRG/New/22	21.007	0.030	0.144	+ 0.014	0.13	99.69	0.19	7.193
LRG/New/24	20.979	0.073	0.349	- 0.014	0.25	99.56	0.19	7.477

Theoretical spacing 20.993 cm, T–The difference between the average achieved and theoretical spacing, LRG-large round grain; MRG-medium round grain; LFG-large flat grain; MFG-medium flat grain.

When sowing the LFG fraction, a significant improvement in sowing quality is visible with the use of the new seed eliminator. The best result of sowing the LRG fraction with the original eliminator was achieved at position "22", where we achieved an average sowing distance of 21.055 or + 0.062 cm compared to the theoretical distance of 20.993 cm. In this position, the original seed eliminator achieved a QFI index of 99.68 with a Miss index of 0.31. Similar results were achieved using the new seed eliminator, which achieved a slightly better Prec.index of only 7.193. Statistical comparison of the obtained data did not reveal any significant differences. Authors Banaj et. al. (2022) state in their research that during the sowing simulation ( $6 \text{ km h}^{-1}$ ) they achieved the most favorable position of the seed eliminator at the factory mark 12, i.e. the first tooth of the remover was 2.60 mm from the center of the hole ( $\varnothing 4.5 \text{ mm}$ ) on the vacuum plate. At the same time, tooth 5 was only 0.50 mm away. The most favorable position of the seed eliminator is stated by the authors Banaj et. al. (2021a) in the case of the PSK Olt sowing machine when sowing sunflowers (with an average length of 9.581 and a width of 5.049 mm and a thickness of 4.088 mm) was recorded at the distance of the last (fifth) tip of the tooth from the center of the vacuum plate hole ( $\varnothing 3.5 \text{ mm}$ ) by 1 mm. When sowing the same seed with the MaterMacc Twin Row-2 sowing machine, when using a vacuum plate  $n=12$  and  $\varnothing 3.5 \text{ mm}$ , the best distant tip of the twelfth tooth from the center of the vacuum plate hole was determined to be 1.20 mm.



**Figure 5** Presentation of the achieved QFI indices for the examined seed eliminators

## CONCLUSION

After conducting research on the test table of two different seed eliminators during the simulation of the working speed of the seeder of 6 km h<sup>-1</sup> when using 4 fractions of corn seeds, the following conclusions can be made:

- the LRG corn fraction had the highest thickness of 6.83 mm and width of 8.80 mm and the highest average absolute mass of 374.25 g with an average hectoliter mass of 66.18 kg at a moisture content of 9.95 %,
- the smallest fraction of corn was MFG with an absolute mass of only 287 g and the smallest width of 8.16 mm,
- the new seed eliminator in position "20" when working with the MFG fraction achieved a slightly better QFI index of 99.69 and a Mult index of 0.19 and a Miss index of only 0.13. The same seed eliminator achieved Prec. index of 8.53,
- when working with the MRG fraction, similar results were achieved, which indicate, based on the QFI index, that the new seed eliminator also achieved slightly better results, with Prec. index of 7.127.
- however, in the case of the largest LRG fraction, the results obtained by both seed eliminators were equal, and the QFI achieved by both was a high 99.69.

Since the research indicates the possibility of improving the sowing, i.e. achieving uniformity of spacing, the research will continue with the simulation at other working speeds as well as the use of seeds of other agricultural crops.

## REFERENCES

- Banaj, A., Šumanovac, L., Heffer, G., Tadić, V., Banaj, Đ. (2017). Yield of corn grain by sowing in twin rows with MaterMacc-2 planter. In *Proceedings of the 45th International Symposium on Agricultural Engineering, Actual Tasks on Agricultural Engineering, 21-24 February 2017, Opatija, Croatia* (pp. 141-152). University of Zagreb, Faculty of Agriculture.
- Banaj, A., Banaj, Đ., Tadić, V., Petrović, D., Stipešević, B. (2019). Utjecaj sustava sjetve na prinos zrna kukuruza različitih FAO grupa. *Poljoprivreda Osijek*, 25/2, 62-70, doi:10.18047/poljo.25.2.9
- Banaj, A., Banaj, Đ., Petrović, D., Stipešević, B., Tadić, V. (2021 a.). Sustavi sjetve kao čimbenik prinosa zrna u proizvodnji suncokreta. *Poljoprivreda* 27 (2), 84-90
- Banaj, A., Banaj, Đ., Petrović, D., Stipešević, B., Tadić, V. (2021.). The impact of maize fraction and technical adjustment factors on the working quality of the PSK4 sowing machine. *Poljoprivreda* 27(1), 11-21.
- Banaj, Anamarija; Banaj, Đuro; Stipešević, Bojan; Nemet, Franjo; Jurković, Dragan (2022). Utjecaj obodne brzine sjetvene ploče na razmak u sjetvi kukuruza kokičara // *Journal of Central European agriculture*, 23 (2022), 3; 642-654 doi:10.5513/JCEA01/23.3.3545
- Banaj, Đ. & Šmrčković, P. (2002). Upravljanje poljoprivrednom tehnikom, Udžbenik, *Poljoprivredni fakultet u Osijeku*.
- Berus P. (2010). Vpliv hitrosti setve na točnost odlaganja semena pri pnevmatski podtlačni sejalnici za koruzo. Dipl. delo. Ljubljana, Univ. v Ljubljani, Biotehniška fakulteta, Odd. za zootehniko. pp. 70.
- Findura, P., Turan, J., Jobbágy, J., Angelovic, M. (2012). Influence of the physical attributes of seeds on the sowing quality within selected sowing mechanism. *Cont. Agr. Engng.*, 38(1):1–8
- Staggenborg, S. A., Taylor, R. K., Maddux, L. D. (2004). Effect of planter speed and seed firmers on corn stand establishment. *Applied Engineering in Agriculture*, 20(5): 573–580. doi: 10.13031/2013.17457

- Karayel, D., Wisenhoff, M., Özmerzi, A., Müller, J. (2006). Laboratory measurement of seed drill seed spacing and velocity of fall of seeds using high-speed camera system. *Computers and Electronics in Agriculture*, 50 (2): 89-96. <https://doi.org/10.1016/j.compag.2005.05.005>
- Lauer, J.G. (2001). Theoretical and experimental evaluation of within-row plant spacing in corn. In Annual Meetings Abstracts (CD-ROM). ASA, CSSA, and SSSA, Madison, WI.
- Onal, I. (2006): Tek dane ekimin matematik-istatistik esasları ve ekim makinalarının denemelerinde kullanılması. In: Tarımsal Mekanizasyon 23. Ulusal Kongresi (Eds. I Kavdır, H Kocabıyık, SK Sumer, MB Buyukcan), Canakkale, pp 97-102.
- ONAL I., DEĞİRMENCİOĞLU A., YAZGI A. (2012): An evaluation of seed spacing accuracy of a vacuum type precision metering unit based on theoretical considerations and experiments, *Turk J Agric For* 36 (2012): 133-144, DOI:10.3906/tar-1010-1316
- Vitas, N., Bilandžić, M. (1990.): Ispitivanje sijačice PSK-OLT na probnom stolu pomoću osobnog računala, Primjena kompjutera u poljoprivredi – Osijek 1990., 84-88.
- Yazgi, A., Değirmencioğlu, A., İsmet, O., Bayram, E. (2010.): Mathematical Modelling and Optimization of the Performance of a Metering Unit for Precision Corn Seeding. *Tarım Makinaları Bilimi Dergisi* 6 (2), 107-113
- Yazgi, A., Değirmencioğlu, A. (2016) Development of Prediction Functions for a Maximized Precision Seeding Performance Based on Optimized Variables. *Ege Üniv. Ziraat Fak. Derg.*, 2016, 53 (2):179-187 [doi:https://doi.org/10.20289/zfdergi.389108](https://doi.org/10.20289/zfdergi.389108)
- Zimmer, R., Košutić, S., Zimmer, D. (2009.): Poljoprivredna tehnika u ratarstvu, Osijek

---

---



## INTEGRATED DETERMINATION OF TRACTOR CENTRE OF GRAVITY AND LATERAL ROLLOVER ANGLE

Giovanni CARABIN<sup>1\*</sup>, Lorenzo BECCE<sup>2</sup>, Andreas MANDLER<sup>1</sup>, Fabrizio MAZZETTO<sup>1,2</sup>

\*E-mail of corresponding author: giovanni.carabin@unibz.it

<sup>1</sup>Faculty of Science and Technology, Free University of Bozen-Bolzano,  
Piazza Università 5, 39100 Bolzano, Italy.

<sup>2</sup>Competence Centre for Plant Health, Free University of Bozen-Bolzano,  
Piazza Università 5, 39100 Bolzano, Italy.

### ABSTRACT

*Tractor roll-over is one of the major safety issues particularly when these machines operate in mountainous environments. This causes nearly 140 fatal accidents each year in Italy, and many other cases still result in considerable vehicle damages and loss of income from lost work. Therefore, the development and implementation of stability models to study the behaviour of existing vehicles operating in hazardous conditions results very important, especially if they are originally designed to work on flat surfaces. From them, new solutions can be integrated into the vehicles control systems to warning the operator when an instability is approaching, or to implement automatic countermeasures to prevent it. However, the validation of these models is still a challenge as they must be compared and calibrated with experiments on real machines (i.e., too much complexity in working with bulky and heavy machines even from a safety point of view). In this work a four-wheel-drive narrow-track tractor (New Holland TN75V) is considered as a test case. Firstly, a mathematical model of static rollover stability was derived to predict all instabilities for any orientation of the machine. The results are then compared with an experimental test campaign performed on a real tractor and taking advantage of an innovative vehicle stability test rig available at the Agroforestry Innovations Lab (AFILAB) of the Free University of Bozen-Bolzano.*

**Keywords:** Roll-over stability, safety, rotating test-rig, tractor stability, Centre of Gravity determination.

### INTRODUCTION

One of the main safety issues that affects tractors, or earth-moving machines, operating in mountainous environments is the roll-over. This causes, on average, between 110 and 140

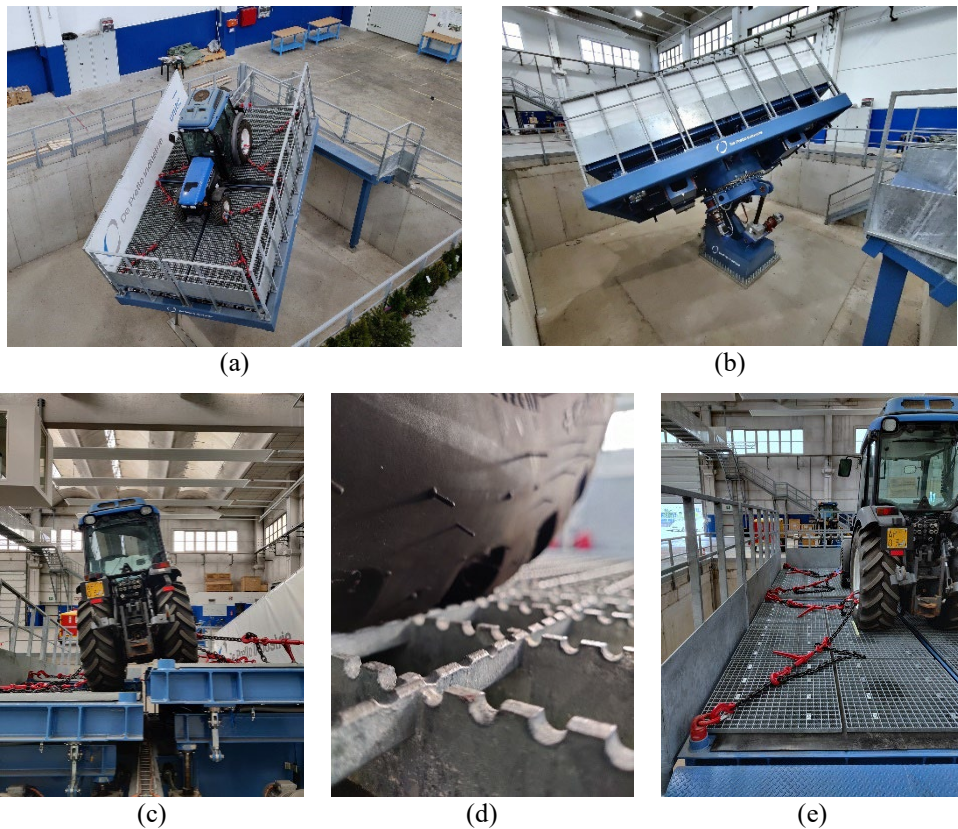
fatal accidents every year in Italy (Facchinetti et al., 2021). Even if in the best cases operators are not or only minimally injured, as consequence considerable damages to vehicles and loss of income from missed work are implicated (Bietresato and Mazzetto, 2020). Therefore, the development and implementation of stability models to study the behaviour of existing vehicles operating in hazardous conditions results very important, especially if they are originally designed to work on flat surfaces. From them, new solutions can be integrated into the machines control systems to warning the operator when an instability is approaching, or to implement automatic countermeasures to prevent it (e.g., inhibition of the steering in the direction of instability, automatic blocking of the pivoting, etc.) (Bietresato et al., 2020; Carabin et al., 2016; Rondelli et al., 2013). In the literature many works (e.g., (Franceschetti et al., 2021, 2014; ISO-16231-2, 2015; Majdan et al., 2021; Pessina et al., 2022; Yang et al., 2020)) are related to the lateral roll-over stability, which represents the most critical condition for safety. Typically, they focus on a specific tractor/platform configuration, e.g., tracked, 4-wheeled, with a rigid body or an articulated-body, etc. More complex and generic studies (Bietresato and Mazzetto, 2020; Carabin et al., 2016; Previati et al., 2014; Vidoni et al., 2015) consider the stability of a tractor in different orientations and conditions. Generally, with some exceptions (Majdan et al., 2021; Pessina et al., 2022), these works are based on the definition of a mathematical model of the phenomena, which is then exploited to study the stability under different conditions. However, an experimental validation is not performed, as it is complex to work with bulky and heavy machines as well as the necessary equipment is expensive. Finally, some authors (Bietresato et al., 2020; Lontis et al., 2021; Simion and Nastase, 2009) propose some studies about the tractor dynamic stability tests. Anyway, these are not covered by the standards, as they are difficult for the driver (necessarily on board) to perform safely. This work focuses on the study of static rollover stability of 4-wheeled tractors with rigid-frames and pivoting front-axes. In particular, a four-wheel-drive narrow-track New Holland TN75V has been considered as a test case. The narrow-track characteristics (i.e., rear or front track smaller than  $1150\text{mm}$  (Pessina et al., 2022)) allows to work easily between rows of orchards and vineyard, but it becomes very susceptible to lateral rollover (Pessina et al., 2022). Firstly, a mathematical model of static rollover stability was derived to predict all instabilities for any orientation of the machine: from the most dangerous lateral instability to the longitudinal one, passing through all the intermediate configurations. Unlike most of the works, the results were evaluated through an experimental test campaign performed on a real tractor and taking advantage of an innovative vehicle stability test rig available at the Agroforestry Innovations Lab (AFILAB) of the Free University of Bozen-Bolzano. This consists in a tilting and rotating platform capable of moving a tractor placed on it (up to a weight of 10 tons) in any orientation. A series of load cells, integrated into the support plane, then measure the forces discharged to the ground by each wheel/track. Beyond evaluating the tractor stability limit tilting angle, this routable testing-rig is also exploited to tune the mathematical model by determining some of the physical parameters of the tractor involved into the stability problem (e.g., CoG - Centre of Gravity position).

## MATERIALS AND METHODS

### *Stability test-rig*

The experimental study of a tractor rollover stability as well as the determination of some of its important physical parameters have been performed through a new stability test-rig available at the Agroforestry Innovations Lab (AFILAB) of the Free University of Bolzano.

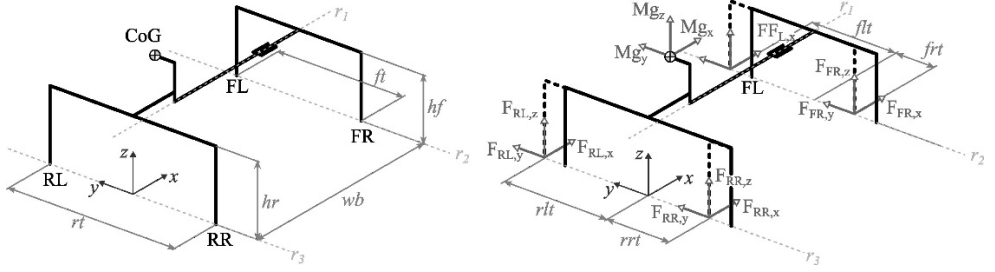




**Figure 1** (a) Stability test-rig, (b) rotational degrees of freedom, (c) plane conformation, (d) plate special metal grid, (e) tractor anchoring with chains

As visible in figure 1a and 1b, it consists in a rotating supporting plane capable of orientate and tilting in a quasi-static way any machine located on it (up to a weight of 10 tons and a dimension of about 6x4m). The mechanical system (figure 1b) allows for two different motions: (1) support plane tilting ( $\alpha$  angle) up to an angle of  $55^\circ$  and (2) support plane rotation around an axis normal to its surface ( $\beta$  angle) from  $-175^\circ$  to  $175^\circ$  (Bietresato and Mazzetto, 2022). In addition, the support plane is divided in four plates, each of which can be lowered and/or raised to simulated uneven terrains with the presence of bumps or potholes (figure 1c). Then, a series of load cells integrated into each of the four support plane plates continuously measure the contact forces between wheels/tracks and the ground. In this way, it is possible to monitor the stability state and determine the beginning of a rollover as soon as one of the four forces become zero. Special metal grids, equipped with small reliefs that fit into the tire rubber (figure 1d), are used to prevent, or at least limit, the machine from sliding on steep slopes. However, the tractor is still anchored for safety reasons with a series of chains (figure 1e). Even if they are kept loose so as not to interfere with the measurement (e.g., a wheel can detach from the ground for a certain amount). By combining all of the platform motions, different kind of test and certification procedures can be realized on a machine, such as the

rollover stability determination, the localization of the gravity centre, the study of the behaviour of a tractor passing through a hole or over an obstacle, the influence of implements over stability, etc.



**Figure 2** Kinematic model

### **Tractor roll-over stability model**

In this work common tractors schematic with 4 wheels drive transmission and a pivoting front axle are considered. In order to study and simulate the stability behaviour of the tractor, a simplified model of its kinematics has been developed based on the work of Previati et al. (Previati et al., 2014). The following hypothesis have been assumed: (1) the tyre-terrain contact force has direction according to the action of gravity, (2) the tyre-terrain contact area is considered as a point located in the middle of tyre width in stable conditions, (3) while when approaching the rollover conditions it is located at 1/3 of the width of the tyre in the downhill direction, (4) the front axle is symmetric and (5) the front pivoting axle is frictionless. With reference to figure 2 the normal components of the reaction forces acting on the tyres can be computed considering the momentum equilibrium around the axis  $r_3$ ,  $r_2$  and  $r_1$  of the front and rear part separately. This corresponds to solve the following system of equations:

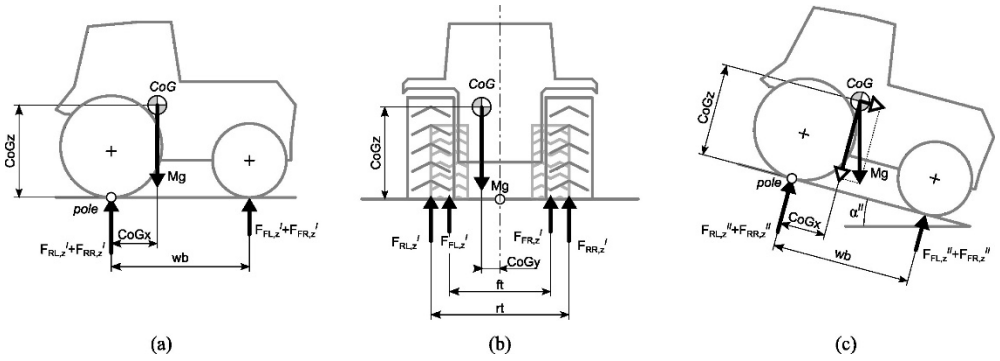
$$\left\{ \begin{array}{l} (F_{FL,z} + F_{FR,z})wb - Mg_x CoG_z + Mg_z CoG_x = 0 \\ (F_{RL,z} + F_{RR,z})wb + Mg_x CoG_z + Mg_z (wb - CoG_x) = 0 \\ F_{RL,z} rlt - F_{RR,z} rrt + (F_{RL,y} + F_{RR,y})hf - Mg_y (CoG_z - hf) + \\ \quad + Mg_z CoG_y = 0 \\ (F_{RL,z} - F_{RR,z})\frac{rt}{2} + (F_{RL,y} + F_{RR,y})hf - Mg_y (CoG_z - hf) + Mg_z CoG_y = 0 \\ F_{FL,z} flt - F_{FR,z} frt + (F_{FL,y} + F_{FR,y})hf = 0 \end{array} \right. \quad (1)$$

where  $F_{i,j}$  is the  $j$ -th component of the contact force of the  $i$ -th wheel (i.e., FL: front left, FR: front right, RL: rear left, RR: rear right),  $wb$  is the wheelbase,  $ft$  the front track,  $rt$  the rear track,  $hf$  the front axle height,  $hr$  the rear axle height,  $M$  the tractor mass and  $CoG$  the position of the Centre of Gravity. The terms  $rlt = \frac{rt}{2} - \text{sign}(\sin\beta)\frac{wr}{6}$ ,  $rrt = \frac{rt}{2} + \text{sign}(\sin\beta)\frac{wr}{6}$ ,  $flt = \frac{ft}{2} - \text{sign}(\sin\beta)\frac{wf}{6}$  and  $frt = \frac{ft}{2} + \text{sign}(\sin\beta)\frac{wf}{6}$ , with  $w_r$  and  $w_f$  the width of rear and front tyres respectively, take into account for the contact point shifting

(i.e., hypothesis 3). Finally,  $g_x$ ,  $g_y$  and  $g_z$  are the component of the gravity vector referred to the tractor reference system, that can be expressed in function of angles  $\alpha$  and  $\beta$  as:

$$\mathbf{g} = (g_x, g_y, g_z) = g(\sin \alpha \cos \beta, -\sin \alpha \sin \beta, -\cos \alpha) \quad (2)$$

where  $g = 9.81 \frac{m}{s^2}$ . Substituting equation (2) into system (1) and solving for the force components, a close solution can be determined. Here it is not reported for lack of space. This result is exploited to determine static rollover limit angle using a recursive computation: for each orientation (i.e.,  $\beta$  angle), the  $\alpha$  angle is increased starting from  $0^\circ$  and each time the four wheels contact forces are computed. The critical angle is determined as soon as at least one of the forces becomes null or negative.



**Figure 3** Tilting test for the determination of the Centre of Gravity (CoG) location.

### Centre of Gravity determination

As shown in the previous paragraph, one of the parameters that plays an important role in the stability problem is the position of the Centre of Gravity (CoG). Its determination is based on an indirect measure similar to the procedure reported by the ISO 16231-2 standard (ISO-16231-2, 2015). It consists in evaluating the distribution of the forces acting on each wheel when the tractor is on a horizontal plane (figures 3a and 3b) and when it is tilted longitudinally (figure 3c). In these conditions, the following equations can be determined:

$$Mg = F_{RL,z}^I + F_{RR,z}^I + F_{FL,z}^I + F_{FR,z}^I \quad (3)$$

$$CoGx = \frac{F_{FL,z}^I + F_{FR,z}^I}{Mg} wb \quad (4)$$

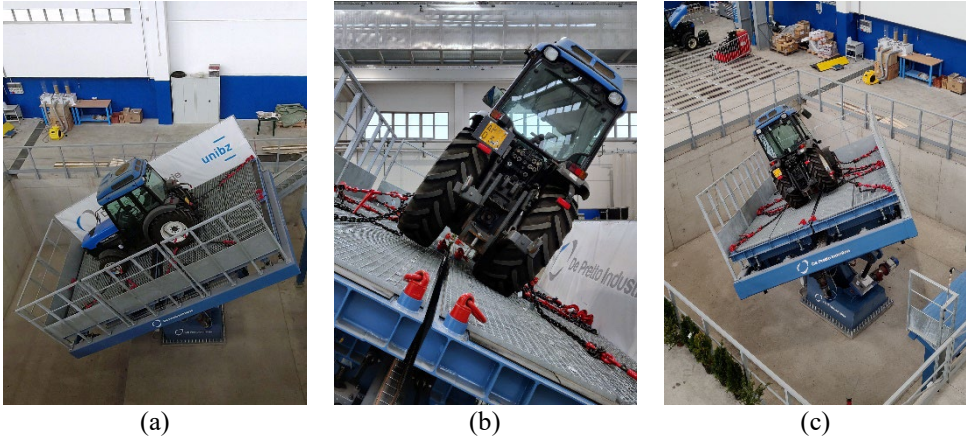
$$CoGy = \frac{(F_{RL,z}^I + F_{RR,z}^I)rt + (F_{FL,z}^I + F_{FR,z}^I)ft}{2Mg} \quad (5)$$

$$CoGz = \frac{(F_{FL,z}^{II} + F_{FR,z}^{II})wb - Mg \cos \alpha^{II} CoGx}{Mg \sin \alpha^{II}} \quad (6)$$

Note that  $CoGx$  and  $CoGz$  are always positive, whereas a positive  $CoGy$  means that the CoG is shifted toward the tractor left side.

**Table 1** New Holland NH-TN75V parameters.

Wheelbase	$wb$	[m]	2.060
Rear axle height	$hr$	[m]	0.518
Front axle height	$hf$	[m]	0.335
Rear track	$rt$	[m]	0.860
Front track	$ft$	[m]	0.850
Rear tyre (360/70 R24) width	$wr$	[m]	0.350
Front tyre (240/70 R16) width	$wf$	[m]	0.270

**Figure 4** (a) CoG determination, (b)(c) determination of the static rollover angle ( $\alpha_{im}$ ) in different orientation ( $\beta$ ).

### Case of study

In this work a New Holland TN75V tractor has been considered as test case. It is a four-wheel-drive narrow-track tractor with a rigid body and a pivoting front axle. It is in its basic configuration with the diesel tank 1/3 filled, the tires inflated to the pressure given in the manual and without the front ballast mounted. The first operation of the experimental test regards the determination of the position of the Centre of Gravity. The tractor is placed on the platform which is initially kept in a horizontal position. By reading the value of the measured forces it is therefore possible to calculate the  $CoGx$  and  $CoGy$  coordinates using equations (4) and (5), respectively. The tractor is then secured with chains (i.e., the chains remain slack so as not to interfere with the measurement) and the platform is tilted (figure 4a). The CoG height can then be calculated according to equation (6). In this case, to reduce the error, the platform was inclined at different angles and therefore an average value for  $CoGz$  has been considered. This first test also allows to calculate the total mass of the tractor, using equation (3). The second part of the experimental campaign concerns the determination of the static rollover angle in different orientations of the machine (i.e., angle  $\beta$  set to  $\pm 45^\circ$ ,  $\pm 90^\circ$  and  $\pm 120^\circ$ ). For

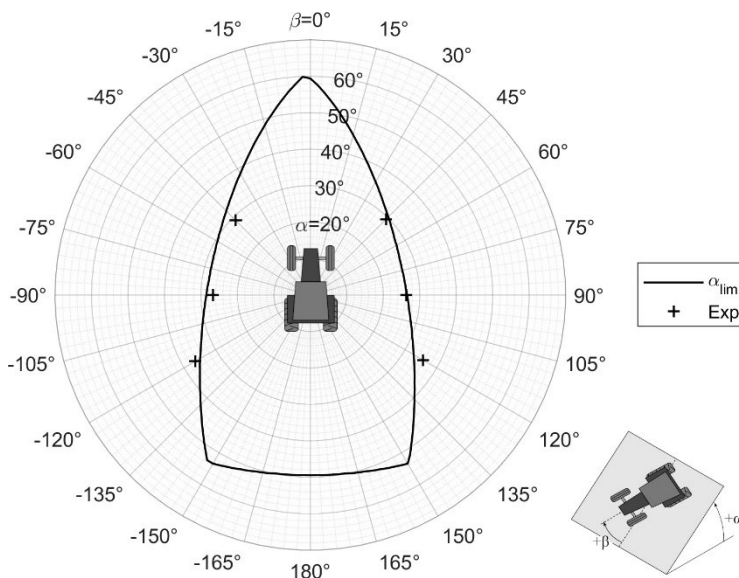
each orientation considered, the platform is then tilted until the value of at least one of the four forces becomes zero and thus the correspondent wheel detaches from the ground (figures 4b and 4c).

## RESULTS AND DISCUSSION

The results of the theoretical model and the experimental tests considering a New Holland TN75V tractor as a test case are presented in this section. The first step involved the determination of the position of the Centre of Gravity. The three coordinates turn out to be equal to:

$$\mathbf{CoG} = (0.816, -0.013, 0.701) \text{ m}$$

This result means, considering the ratio between  $CoGx$  and the wheelbase  $wb$ , that the static weight distribution is 2/5 on the front axle and 3/5 on the rear axle. The mass of the tractor, which has no front ballast, is 2355 kg. These two parameters, along with those given in table 1 have then been used to solve the stability mathematical model (i.e., equation (1)) for different values of the  $\beta$  angle, obtaining the diagram visible in figure 5.



**Figure 5** Rollover stability map expressed as the maximum slope ( $\alpha_{lim}$ ) versus the tractor orientation ( $\beta$ ): result from mathematical model and experimental measures.

It represents the value of the static rollover stability angle  $\alpha_{lim}$  in function of the tractor orientation (i.e.,  $\beta$  angle). The lateral rollover stability (i.e.,  $\beta = \pm 90^\circ$ ) appears to be, as expected, the most critical with values of about  $27^\circ$ . Actually, the two values are slightly different between the left and right side due to the non-symmetrical position of the CoG. The longitudinal rollover stability (i.e.,  $\beta = 0^\circ$  and  $\beta = 180^\circ$ ) reaches the highest values of  $50^\circ$  and  $60^\circ$  for a tilt toward the rear and front part, respectively. Finally, in table 2 and in figure

5 the experimental results of the rollover test for different  $\beta$  angles have been reported. These are almost superimposed on the model predictions, and any deviations are due to the complexity of the rollover phenomenon, which is greatly influenced by factors such as elasticity and tire deformation (figure 4b).

**Table 2** Experimental static rollover limit angles. Determined as the angle for which at least one of the four contact forces becomes null.

$\beta$	$\alpha_{lim}$
45°	29.42°
90°	26.25°
120°	35.70°
-45°	28.97°
-90°	26.73°
-120°	36.38°

## CONCLUSIONS

In this work the study of static rollover stability of 4-wheeled tractors with rigid-frames and pivoting front-axles has been considered. A mathematical model to predict the limit stability angle has been developed and evaluated through an experimental campaign on a real tractor (i.e., New Holland TN75V) and taking advantage of an innovative vehicle stability test rig available at the Agroforestry Innovations Lab (AFILAB) of the Free University of Bozen-Bolzano. This test-rig has been exploited to measure the position of the tractor Centre of Gravity, following a procedure similar to one provided by the ISO standard, but much faster. A rollover stability map has then been computed as result of the developed mathematical model. Finally, a certain number of experimental rollover test have been performed and compared with the model results showing the validity of the method.

## ACKNOWLEDGEMENTS

This research has been carried out within the PNRR research activities of the consortium iNEST (Interconnected North-East Innovation Ecosystem) funded by the European Union Next-GenerationEU (Piano Nazionale di Ripresa e Resilienza (PNRR) – Missione 4 Componente 2, Investimento 1.5 – D.D. 1058 23/06/2022, ECS\_00000043). This manuscript reflects only the Authors' views and opinions, neither the European Union nor the European Commission can be considered responsible for them.

## REFERENCES

Bietresato, M., Belotti, R., von Ellenrieder, K.D., Mazzetto, F., 2020. A Preliminary Study of Active Stabilization for Agricultural Machines Using a Movable Mass. Presented at the ASME 2019

- International Mechanical Engineering Congress and Exposition, American Society of Mechanical Engineers Digital Collection. <https://doi.org/10.1115/IMECE2019-11507>
- Bietresato, M., Mazzetto, F., 2022. A Novel Facility For Statically Testing The Stability Of Vehicles: Technical Features And Possibilities. *Int. J. Transp. Dev. Integr.* 6, 107–121. <https://doi.org/10.2495/TDI-V6-N2-107-121>
- Bietresato, M., Mazzetto, F., 2020. Stability Tests of Agricultural and Operating Machines by Means of an Installation Composed by a Rotating Platform (the “Turntable”) with Four Weighting Quadrants. *Appl. Sci.* 10, 3786. <https://doi.org/10.3390/app10113786>
- Carabin, G., Gasparetto, A., Mazzetto, F., Vidoni, R., 2016. Design, implementation and validation of a stability model for articulated autonomous robotic systems. *Robot. Auton. Syst.* 83, 158–168. <https://doi.org/10.1016/j.robot.2016.05.008>
- Facchinetti, D., Santoro, S., Galli, L.E., Pessina, D., 2021. Agricultural Tractor Roll-Over Related Fatalities in Italy: Results from a 12 Years Analysis. *Sustainability* 13, 4536. <https://doi.org/10.3390/su13084536>
- Franceschetti, B., Lenain, R., Rondelli, V., 2014. Comparison between a rollover tractor dynamic model and actual lateral tests. *Biosyst. Eng.* 127, 79–91. <https://doi.org/10.1016/j.biosystemseng.2014.08.010>
- Franceschetti, B., Rondelli, V., Capacci, E., 2021. Lateral stability performance of articulated narrow-track tractors. *Agronomy* 11. <https://doi.org/10.3390/agronomy11122512>
- ISO-16231-2, 2015. Self-Propelled Agricultural Machinery—Assessment of Stability—Part 2: Determination of Static Stability and Test Procedures.
- Lontis, N., Tucu, D., Malaimare, G., Groza, I.V., 2021. Simulation model of agricultural transport units behaviour on public roads. Presented at the 48th Symposium “Actual Tasks on Agricultural Engineering,” Zagreb, Croatia, 2nd-4th March 2001, pp. 493–500.
- Majdan, R., Abrahám, R., Tkáč, Z., Drlička, R., Matejková, E., Kollárová, K., Mareček, J., 2021. Static Lateral Stability of Tractor with Rear Wheel Ballast Weights: Comparison of ISO 16231-2 (2015) with Experimental Data Regarding Tyre Deformation. *Appl. Sci.* 11, 381. <https://doi.org/10.3390/app11010381>
- Pessina, D., Facchinetti, D., Galli, L.E., Bisaglia, C., Cutini, M., 2022. Survey on the Lateral Stability of Wheeled Narrow-Track Tractors, in: Biocca, M., Cavallo, E., Cecchini, M., Failla, S., Romano, E. (Eds.), *Safety, Health and Welfare in Agriculture and Agro-Food Systems, Lecture Notes in Civil Engineering*. Springer International Publishing, Cham, pp. 457–467. [https://doi.org/10.1007/978-3-030-98092-4\\_47](https://doi.org/10.1007/978-3-030-98092-4_47)
- Previati, G., Gobbi, M., Mastinu, G., 2014. Mathematical models for farm tractor rollover prediction. *Int J Veh. Des.* 64, 280–303. <https://doi.org/10.1504/IJVD.2014.058486>
- Rondelli, V., Martelli, R., Casazza, C., Guarnieri, A., 2013. Methodological approach to assess tractor stability in normal operation in field using a commercial warning device. *J. Agric. Eng.* 44, 659–662. [https://doi.org/10.4081/jae.2013.\(s1\):e132](https://doi.org/10.4081/jae.2013.(s1):e132)
- Simion, P., Nastase, S., 2009. Contributions to the study of the dynamics of agricultural tractors equipped with front-end loader and rear forklift loader.
- Vidoni, R., Bietresato, M., Gasparetto, A., Mazzetto, F., 2015. Evaluation and stability comparison of different vehicle configurations for robotic agricultural operations on side-slopes. *Biosyst. Eng.* 129, 197–211. <https://doi.org/10.1016/j.biosystemseng.2014.10.003>
- Yang, H., Yang, H., Xia, C., Han, J., Chen, C., Zhang, H., Zhang, H., 2020. Analysis of Stability and Dynamic Model Simulation of Mountain Tractor Rollover. Presented at the IOP Conference Series: Earth and Environmental Science. <https://doi.org/10.1088/1755-1315/512/1/012151>

---

---





## USING A DIGITAL MAINTENANCE ASSISTANT TO INDEPENDENTLY MAINTAIN THE PTO SHAFT

Fredrik REGLER<sup>1\*</sup>, Max KRUEGER<sup>2</sup>, Heinz BERNHARDT<sup>1</sup>

\*E-mail of corresponding author: fredrik.regler@tum.de

<sup>1</sup>Chair of Agricultural Systems Engineering, Technical University of Munich,  
Duernast 10, 85354 Freising, Germany

<sup>2</sup>Off-Highway Powertrain Services Germany GmbH, Walterscheid Powertrain Group,  
Hauptstraße 150, 53797 Lohmar, Germany

### ABSTRACT

*In agriculture, maintenance is one of the most important tasks to keep machinery reliable and downtimes low. Specific maintenance plans exist for most modern machines and implements with defined frequencies and tasks from their manufacturers. One part that often got missed out is the agricultural PTO shaft, which is not directly a part of the machine, neither of the implement. Even though, omitted or reduced maintenance of the PTO shaft leads to downtimes of the production.*

*In order to perform maintenance correctly, accurate maintenance instructions need to be available. Digitization can solve the problem of the PTO shaft's unique standing, as operation hours are retraced precisely by a sensor, and the right moment for maintenance is calculated. Commonly, the PTO shaft is maintained together with the implement it is attached to, and its specific maintenance intervals are ignored, even though the manufacturer gives those intervals. Here, the point of view needs to be shifted to the uniqueness of the PTO shaft and its recommended maintenance intervals.*

*This work summarizes the chances and threats of the actual situation of PTO shaft maintenance and introduces an operation hours counter to estimate the right moment for PTO shaft maintenance in combination with a smartphone application. Ultimately, operation hours detection of the PTO shaft gives the opportunity to directly measure the working time of the attached implement. Thereby, older and pure mechanical implements can be digitized, but likewise modern implements benefit from optimized maintenance.*

**Keywords:** maintenance assistant, digitization, PTO shaft maintenance, sensor technique, precision agriculture

## INTRODUCTION

In modern farming, maintenance is one of the usual tasks of the farmer to keep the machines and implements running and prevent failure. Here it needs to be differed between the maintenance of the tractor itself and the implement. The tractor maintenance includes general servicing as changes of oil and other fluids of the engine and transmission, cleaning of the air filters and radiators, check for the mechanical components, and check for road safety (Bello 2013). The maintenance of implements largely differs between the kind of implement and its complexity. A rotary harrow for example needs regular lubrication of the moveable parts, cleaning, and check for its road safety as well. A major maintenance factor for a rotary harrow is the check for the mechanical components, as high loads regularly occur. Thus, the tines are damaged and need to be changed. This is a necessary task before every operation but it is time and labor consuming.

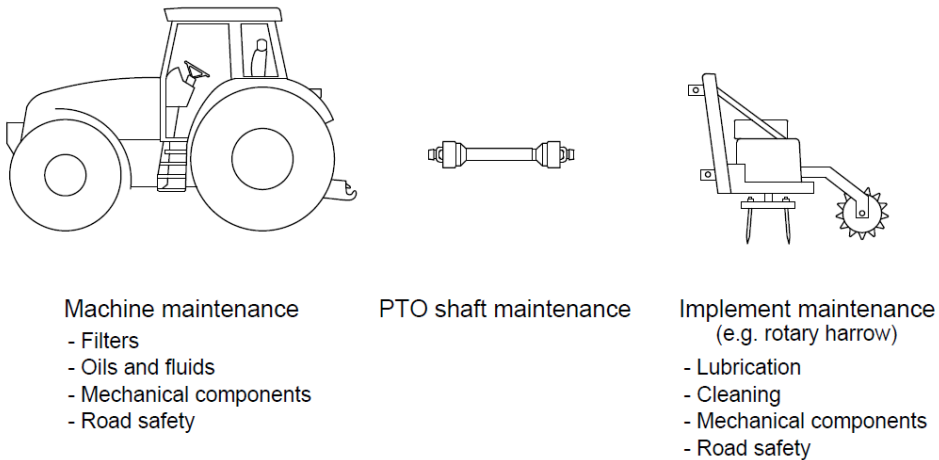
Classical machine maintenance management gets more and more support from digitization, as management systems evolve and adapt continuously. Artificial Neural Networks (ANN), Internet Communication Technology (ICT), or Machine Learning (ML) are used to support the proper maintenance of machines in small- and medium-sized enterprises (Velmurugan et al. 2022). Compared to that, the agricultural maintenance is less advanced and often done by farmers, contractors, or employees themselves and without proper knowledge or awareness, as a previous study finds (Regler et al. 2022). In modern industry, the concept of predictive maintenance became common, but is poorly adapted in agriculture so far. The idea of predictive maintenance is to evaluate raised machine data in real time and predict the condition of different parts. As soon as a critical condition is assumed, the system informs the user that maintenance is necessary (Mobley 2002). Those systems became more common in modern "Industry 4.0" as it is mostly used enhancing machine downtime, costs, control, and quality of production, as Zonta et al. (2020) concluded in their work. The authors reviewed different predictive maintenance systems described in the literature and consider the often-used monitoring and estimation of failure as problematic, as those models don't predict failure for individual cases. For agricultural machinery, a comparable system can be achieved by adapting a torque transducer into the driveshaft of the machine and measures forces. This helps to protect from overload, monitors the power flow, previses the residual fatigue life, and enables basic predictive maintenance compared to the traditional preventive maintenance (Golinelli et al. 2019).

Regarding the maintenance of the tractor, the implement, and the technological evolution of maintenance management, one specific part with a unique standing appears: the agricultural PTO shaft. The agricultural PTO shaft is not considered as part of the tractor, neither as part of the implement, but connects both. It fulfillls different tasks as it directly transfers power from the tractor engine to the implement, balances the tractor PTO with the implement when they don't align, and buffers movement when the longitude changes during curves (Hilgers 2016). Length and angle compensation are major tasks of the PTO shaft and desire proper lubrication during operation to reduce friction and wear, and therefore failure (Gagg and Lewis 2007). This arises the question of how and when proper PTO shaft maintenance should be carried out, as it is not included in the existing maintenance plans of machines, and only general information is given in the manuals of implements, which don't consider specific designs or outer circumstances. Even though the maintenance necessity between implement and PTO shaft hugely differs. Aim of this research is to identify the potential and improvement of PTO shaft maintenance and introduce a digital maintenance assistant consisting of a sensor

and a smartphone application that gives specific information about proper PTO shaft maintenance to the operator.

## MATERIALS AND METHODS

After identifying the PTO shaft and its unique standing (compare figure 1), proper maintenance occurs as a problem. The current situation of maintenance and support given by the PTO shaft manufacturers shall be evaluated at first using an online questionnaire to evaluate the maintenance habits of users and consider further improvement. To define the right moment for PTO shaft maintenance, an operation hours counter is developed, and its areas of application are considered. To evaluate the operation hours of agricultural PTO shafts, a possible approach is the estimation of operation hours using a sensor. Retracing the motion of the PTO shaft, the sensor can be applied directly onto the shaft and should be able to transfer the raised information to a handheld interface or a smartphone. Additionally, it gives out proper information about the maintenance condition of the PTO shaft, and informs the user when the PTO shaft specific interval is due. Different PTO shaft types are considered, which leads to specific maintenance strategies. Finally, the solution is discussed regarding the practicability, reliability, and the impact and changes for the users.



**Figure 1** The agricultural PTO shaft stands unique as the connection between a machine and an implement. PTO shaft maintenance needs to be considered independent from the machine or implement.

## DIGITAL MAINTENANCE ASSISTANT FOR PTO SHAFTS

To identify the need of a digital maintenance assistant, a previous study by Regler et al. (2022) stated the habits of maintenance and desires of support from farmers and contractors. The survey was published from December 20<sup>th</sup>, 2021, until January 31<sup>st</sup>, 2022, online and was completely answered by 812 participants. Regarding the results, maintenance is only carried

out according to the utilization of the machine on 37.4% of the farms, while 23.7% maintain according to a fixed scheme, and 16.2% maintain when they assume it to be necessary. Concluded, maintenance is not carried out properly on most of the farms. The behavior about maintenance documentation is similar to the maintenance itself: 43.1% don't document maintenance at all, while 35.5% use pen and paper for documentation. Digital solutions are only mentioned little. The maintenance behavior of farmers is negligent when the maintenance of special PTO shafts – e.g., standard or wide-angle joints – is considered: Only 54.2% of the participants knew in the first place that specific maintenance intervals for such PTO shafts exist, and only 46.1% of those who know carry out maintenance according to those intervals. Even though PTO shaft manufacturers have developed specific maintenance plans for specific PTO shaft types which consider outer factors (Walterscheid Powertrain Group 2022b) or recommend a general maintenance interval for their PTO shafts (Bondioli & Pavesi S.p.A. 2022), most farmers or contractors ignore those. Considering these circumstances, an easy to use, practical, and digital solution to the problem of maintenance mentality is needed to support the user.

In order to provide the right information and tools for the optimal maintenance of PTO shafts, the digital maintenance assistant for PTO shafts was developed. The Walterscheid Connected Service maintenance assistant provides all relevant information for the operation, service, and maintenance of PTO shafts through the smartphone application “Walterscheid Connected Service Assistant” (figure 2). Walterscheid Connected Service has been developed together with farmers and agricultural contractors from different sizes and applications to guarantee an efficient approach for maintenance activities in current farm operation.

The new smartphone application (Walterscheid Connected Service assistant) conducts the farm assets with the current operation hours and the corresponding maintenance intervals and activities within a simple overview. The current condition and latest maintenance activities are synchronized between all farm or contractor employees.

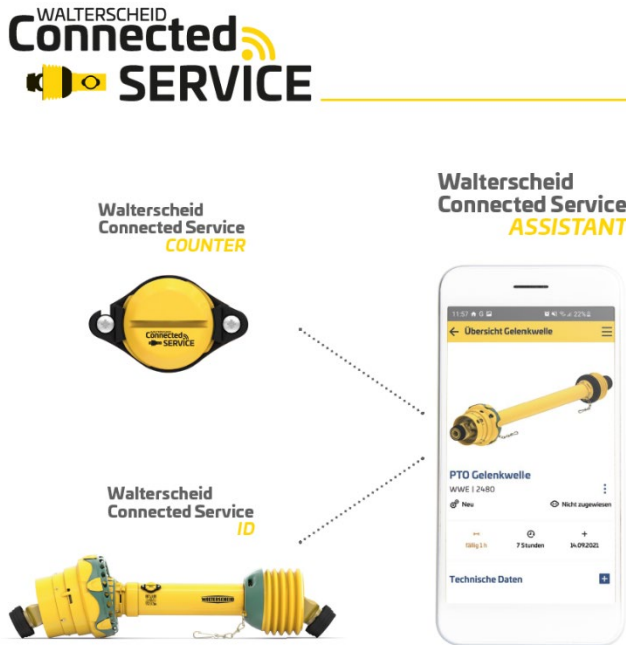
During the asset registration process, the type, and application of implement or machine is defined by the user. The corresponding PTO shaft can be registered automatically using the QR-code with an inherent serial number printed on the PTO shaft (see figure 2, Walterscheid Connected Service ID). Even old PTO shafts without serial numbers can be registered manually by the definition of type and maintenance interval. The digital maintenance assistant calculates the correct maintenance interval for the PTO shaft in regard to the type of application. All required information of the PTO shaft including technical specification, operator's manual, and installation instruction are available through the smartphone application (Walterscheid Connected Service Assistant). After registration, the digital maintenance assistant reminds the user of upcoming maintenance intervals and guides him to perform the regreasing with all relevant information, e.g., type and volume of grease and the location of grease jerks on the PTO shaft. After the greasing process, the maintenance history is generated by the time stamp, user information, and optional user comments. Thereby, the owner can check the maintenance history and current findings on the smartphone application, providing an overview of all registered machines and PTO shafts in his fleet.

PTO and secondary shafts are dedicated to specific implements. Agricultural implements can be attached to different tractors over the season. For implements without ISOBUS-connection, the identification of real usage and operation hours of the implement is nearly impossible today. To be able to track the real usage of an implement and deduct the operation hours of the machine and its components, the Walterscheid Connected Service Counter was

developed. The counter is a battery powered sensor beacon, which is mounted on the protection guard of the PTO shaft in order to sense the operation of the shaft (see figure 2). The operation hours are deducted from the movement of the shaft and are communicated via Bluetooth protocol to the smartphone application. In most applications, the implement is active when the PTO shaft is in rotation. Thus, the operation hours of the implement can be received in the same way by the counter sensor. This solution can be retrofitted to any type of PTO powered implement and therefore can be used for the whole (mixed) fleet of the farm or the contractor.

Using such a system, PTO shaft maintenance gets more precise and excessive maintenance is prevented, which reduces the quantity of consumable inputs and labor time needed for maintenance. Additionally, constant communication between the farmer and his employees is necessary for proper machine maintenance and lubrication, which is a major management task for farms or contractor companies with numerous employees. The right management can be supported by digitized approaches but needs to be accepted and applied in a very classical field (Velmurugan et al. 2022). Here, simple and handy solutions are needed, which is given by the operation hours analysis of the PTO shaft.

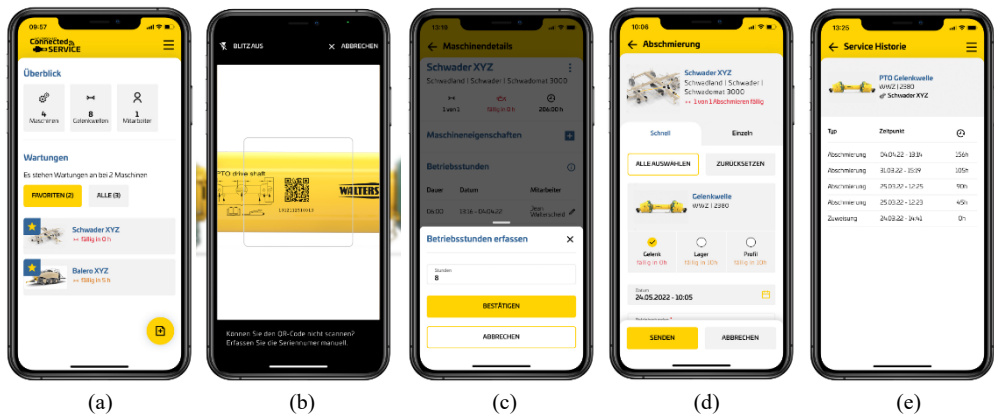
In general, maintenance is considered as routine for the farmer, which means that preventive and corrective maintenance is the standard procedure on farms (Da Silva et al. 2019).



**Figure 2** Overview of the digital maintenance assistant for PTO shafts “Walterscheid Connected Service” (Walterscheid Powertrain Group 2022a)

In a previous study, Regler et al. (2023) calculated the possible savings of labor time and usable input compared to “maintaining a PTO shaft before every usage” or “completely omitting maintenance” to “maintaining a PTO shaft when the manufacturer recommends to”. They came to a comparable result as Da Silva et al. (2019) and achieved an average labor time reduction of 81.8% and a cost reduction of up to 93.8%. An additional advantage of the operation hours analysis is the actual machine time detection, which gives information about the time in use of every implement, no matter if the implement is already digitized and modern, an older, or a simple mechanic implement like a rotary harrow or a rotary cultivator. For older implements, this gives the opportunity to support and optimize implement maintenance as well, as the correct operation hours of the implement is detected. With such a sensor, the basic digitization of every older PTO driven implement becomes possible. The maintenance of those implements can then be included in the management system to schedule maintenance when necessary. For all implements, the Walterscheid Connected Service Assistant is able to support the user with different functions:

- Easy management of the whole machine fleet (figure 3a)
- Quick identification of the specific PTO shaft via imprinted QR-code (figure 3b)
- Tracking of the operation hours (figure 3c)
- Detailed maintenance instructions for the specific PTO shaft with the positioning of the grease zerks, the amount of grease needed for lubrication, and the estimated time until the next maintenance for every specific component is due (figure 3d)
- A digital check book to retrace former maintenance (figure 3e).



**Figure 3** Different functions of the Walterscheid Connected Service Assistant with machine management (a), identification (b), operation hours (c), maintenance instructions (d), and digital check book (e) (Walterscheid Powertrain Group 2022a).

Those functions together give the farmer or contractor the possibility to track the exact usage of its PTO shafts in use and keep maintenance according to the scheduled plans of the manufacturer. The additional function to document maintenance from different devices gives the opportunity for companies with numerous employees to keep better track of the actual maintenance condition of the PTO shaft by the person in charge, even though agreements

about maintenance among the employees are simplified. Therefore, operation of the PTO shaft is retractable, and maintenance can be optimized.

## CONCLUSIONS

The maintenance of agricultural PTO shafts needs to be improved, as the PTO shaft is a critical component for the production process. In other industries, predictive maintenance became common, but in agriculture is still a chance for digitization to improve the predominant and error-prone maintenance behavior of farmers. Here, an operation hours counter is a possible solution.

The developed counter sensor detects the actual time the PTO shaft is in use and calculates the right moment for maintenance according to outer circumstances and use. This gives the opportunity to save labor time and consumable input for unnecessary maintenance. Additional information about the condition of the PTO shaft and the using time of the machine or implement is displayed in the associated smartphone application. Here, the user gets additional information about the maintenance condition, the user manual, or the properties of the PTO shaft the sensor is attached to, beside the information of operation hours.

In future work, the added value of such a sensor will be evaluated in a field study. Additionally, the reduction of environmental losses due to excessive lubrication compared to an improved maintenance system will be evaluated.

## ACKNOWLEDGEMENTS

The project SMART-PTO is supported by funds of the Federal Ministry of Food and Agriculture (BMEL) based on a decision of the Parliament of the Federal Republic of Germany via the Federal Office for Agriculture and Food (BLE) under the innovation support programme.

## REFERENCES

- Bello, S. R. (2013). *Farm Tractor Systems: Maintenance and Operation*: DPS Dominion Publishing Services. Available online at [https://www.researchgate.net/publication/275642331\\_Farm\\_Tractor\\_Systems\\_Operations\\_and\\_Maintenance](https://www.researchgate.net/publication/275642331_Farm_Tractor_Systems_Operations_and_Maintenance), checked on 10/26/2022.
- Bondioli & Pavesi S.p.A. (2022). *Service 015. Werkstatt-Handbuch*, 18ff. Available online at [https://www2.bypy.it/Cataloghi\\_prodotti/pdf/398C37500\\_0.pdf#search=schmierren](https://www2.bypy.it/Cataloghi_prodotti/pdf/398C37500_0.pdf#search=schmierren).
- Da Silva, C.; Rodrigues de Sá, J.; Menegatti, R. (2019). Diagnostic of Failure in Transmission System of Agriculture Tractors Using Predictive Maintenance Based Software. In *AgriEngineering* 1 (1), pp. 132–144. DOI: 10.3390/agriengineering1010010.
- Gagg, Colin R.; Lewis, Peter R. (2007). Wear as a product failure mechanism – Overview and case studies. In *Engineering Failure Analysis* 14 (8), pp. 1618–1640.
- Golinelli, N.; Spaggiari, A.; Castagnetti, D.; Fornari, L.; Dragoni, E.; Gualdi, G.; Brunazzi, A. (2019). Development of a driveshaft torque transducer for low-cost structural health monitoring of off-highway vehicles. In *Proceedings of the Institution of Mechanical Engineers, Part L: Journal of Materials: Design and Applications* 233 (4), pp. 714–720. DOI: 10.1177/1464420716669966.
- Hilgers, M. (2016). Gelenkwelle(n). In M. Hilgers (Ed.): *Getriebe und Antriebsstrangauslegung*. Wiesbaden: Springer Vieweg (Nutzfahrzeugtechnik lernen), pp. 45–46.

- Mobley, R. K. (2002). *Introduction to Predictive Maintenance*. With assistance of R. Keith Mobley. 2nd ed. Oxford: Elsevier Science & Technology (Plant Engineering Ser).
- Regler, F.; Hausmann, F.; Krueger, M.; Bernhardt, H. (2022). Potential and improvement of maintenance efficiency of agricultural machines by a new digital maintenance assistant. In VDI Wissensforum GmbH (Ed.): *International Conference on Agricultural Engineering AgEng-LAND.TECHNIK 2022*, VDI-Bericht 2406: VDI Verlag GmbH, pp.419–428, checked on 12/8/2022.
- Regler, F.; Hausmann, F.; Krueger, M.; Bernhardt, H. (2023). Potential and improvement of maintenance efficiency of agricultural PTO shafts by a new digital maintenance assistant. (in press). In *Agriculture*.
- Velmurugan, K.; Saravanasankar, S.; Bathrinath, S. (2022). Smart maintenance management approach: Critical review of present practices and future trends in SMEs 4.0. In *Materials Today: Proceedings* 62, pp. 2988–2995. DOI: 10.1016/j.matpr.2022.02.622.
- Walterscheid Powertrain Group (2022a). *Walterscheid Connected Service Assistant – Jetzt besser APPschmieren!* Edited by Walterscheid Powertrain Group. Available online at <https://www.walterscheid.app/>, updated on 6/1/2022, checked on 6/1/2022.
- Walterscheid Powertrain Group (2022b). *Walterscheid GmbH | ServicePlus System*. Available online at <https://www.walterscheid.com/en/serviceplus/>, updated on 5/24/2022, checked on 5/24/2022.
- Zonta, T.; Da Costa, C. A.; Da Rosa Righi, R.; Lima, M. J. de; Da Trindade, E. S.; Li, G. P. (2020). Predictive maintenance in the Industry 4.0: A systematic literature review. In *Computers & Industrial Engineering* 150, p. 106889. DOI: 10.1016/j.cie.2020.106889.





## EFFECT OF STRIP TILLAGE AND DIRECT SEEDING ON WINTER WHEAT YIELD, DIESEL CONSUMPTION AND ENVIRONMENT

Zita KRIAUCIŪNIENĖ<sup>1\*</sup>, Lina SALDUKAITĖ<sup>2</sup>, Sidona BURAGIENĖ<sup>2</sup>,  
Aida ADAMAVIČIENĖ<sup>1</sup>, Andrii ZABRODSKYI<sup>2</sup>, Egidijus ŠARAUSKIS<sup>2</sup>

\*E-mail of corresponding author: zita.kriauciuniene@vdu.lt

<sup>1</sup>Department of Agroecosystems and Soil Sciences, Faculty of Agronomy, Agriculture Academy, Vytautas Magnus University, Studentu Str. 11, LT-53361 Akademija, Kaunas Dist., Lithuania

<sup>2</sup>Department of Agricultural Engineering and Safety, Faculty of Engineering, Agriculture Academy, Vytautas Magnus University, Studentu Str. 15A, LT-53362 Akademija, Kaunas Distr., Lithuania

### ABSTRACT

*Crop production is often highlighted as one of the most significant areas of agriculture that provides humanity with food raw materials. However, it also has a fundamental problem – environmental pollution. In order to avoid or reduce the impact of agricultural technological processes on the environment, solutions are sought that would not only be long-term and sustainable, but would help continue and develop farmers' activities without affecting negatively crop yields. For these reasons, various energy-saving technologies, which are characterized not only by less environmental impact, but also by lower diesel fuel, time, energy consumption and costs, as well as lower GHG emissions into the environment, have been widely used. The aim of this study was to investigate and evaluate the use of strip tillage and seeding machines and direct seeding machines in different soil tillage technologies, and also to evaluate the efficiency in terms of yield, diesel consumption, and environmental impact. The research was conducted in 2020–2021 at the Vytautas Magnus University Agriculture Academy Experimental Station. Winter wheat (*Triticum aestivum* L.) was cultivated using three different tillage technologies: conventional tillage with ploughing (CT), minimal stubble cultivation (MT), no tillage (NT) and two sowing machines: strip tillage and seeding (STS) and direct seeding (DS). Research has shown that minimal tillage had a positive effect on the yield of winter wheat. Applying the NT-STS technology resulted in a higher yield (7.3 t ha<sup>-1</sup>) than applying the conventional tillage method CT-STS (6.9 t ha<sup>-1</sup>). A lower CO<sub>2</sub> concentration (0.99 ppm) than in NT-STS (1.14 ppm) was found in the soil in the NT-DS treatment. The highest yield of winter wheat was determined in NT-DS. The highest total fuel consumption (66.2 L ha<sup>-1</sup>) and the*

*total costs of technological processes (202.8 Eur ha<sup>-1</sup>) were determined in the application of conventional tillage and strip sowing technological operation, while the lowest consumption and costs were 25.2 L ha<sup>-1</sup> and 112.1 Eur ha<sup>-1</sup>, respectively, in direct seeding in uncultivated soil.*

**Keywords:** *Strip tillage, direct sowing, Triticum aestivum L., fuel consumption, CO<sub>2</sub> concentration in the soil.*

## INTRODUCTION

Recently, there has been a lot of concern about the human impact on nature and the consequences of its activities. Agriculture is named as one of the most polluting sectors in Lithuania, but by applying nature-friendly agrotechnologies, agriculture could be one of the main ways to solve this problem (Konstantinavičiūtė et al., 2017). It is predicted that the global average temperature might rise between 1.1 and 6.4°C during this century if no emission reduction policies are implemented.

The highest impact on environmental pollution is the emission of CO<sub>2</sub> from motor vehicles and agricultural machines, which cause the greenhouse effect and climate change (Al-Mansour and Jecic, 2017). In order to save the soil and the environment, technologies that are characterized by low environmental pollution, low costs of diesel fuel, energy and working time have been increasingly applied (Pandey and Agrawal, 2014).

According to scientists, CO<sub>2</sub> emissions from the soil depends proportionally to the volume of mechanically disturbed soil (Reicosky and Archer, 2007). According to Feizienė et al. (2012) CO<sub>2</sub> emissions are determined by the depth and intensity of mechanical cultivation of the soil. CO<sub>2</sub> emissions are directly increased by intensive tillage. Other scientists also state that intensive tillage increases the release of CO<sub>2</sub> into the atmosphere (Arlauskas, 1994; Maikštėnienė et al., 2007).

According to Singh et al. (2008) about 30% of the total energy input in crop production is tillage. Each tillage technological operation causes different and uneven environmental impacts because resources are used differently (Sørensen et al., 2014). According to Soni et al. (2013) intensive, traditional tillage with a plough produces the highest greenhouse gas (GHG) emissions compared to other tillage technologies. The analysis of different tillage technologies is necessary to choose tillage technological operations with the lowest energy consumption and negative impact on the environment and generally reducing the use of agricultural machinery (Rusu, 2014). Applying reduced tillage minimises soil erosion, improves soil structure and stability and other physical properties (Jodaugienė, 2002; Buragienė et al., 2011; Steponavičienė, 2017). When the soil is tilled minimally before sowing, the activity of microorganisms becomes more intense, its structure is less damaged, and the crop residues are mixed in the upper layer of the soil (Avižienytė, 2013).

It has been established that the most efficient and environmentally friendly tillage and sowing technology is strip tillage and sowing. This technology, compared to others, less harmful to the soil and its structure, reduces working time (even about 3–4 times), fuel (consumes 38.96 l ha<sup>-1</sup> less than deep tillage), fertilizers (about 30%) and seeds (about 20%) costs, emits less CO<sub>2</sub>, reduces soil erosion caused by wind and water, the stubble left in the rows better retains the moisture needed by plants. By applying the strip tillage technology,

the proper quality of seed placement is ensured, and the yield increases even by 10–20%, compared to plough tillage technology (Mugauskienė, 2017).

As there is still not enough research performed to determine the effect of strip tillage and seeding on ploughed soil, the aim of this work was to investigate and evaluate the use of strip tillage and seeding machines and direct seeding machines on differently prepared soils, and also to evaluate the efficiency of the technologies in terms of yield, energy and impact in relation to the environment.

## METHODS

Experimental research was carried out at the Experimental Station of Vytautas Magnus University Agriculture Academy in 2020–2021. Winter wheat (*Triticum aestivum* L.) was grown in the research field, and winter rapeseed was the pre-crop. Soil properties tests were carried out according to a predetermined schedule: before tillage and sowing; after sowing; 4 weeks after sowing; at the end of the growing season; after vegetation renewal; pre-harvest and during harvest. The length of the field used for research was 150 m, and the width was 25 m. The entire research field was divided into 3 sections, the soil of which was cultivated differently: 1) conventional tillage with ploughing (CT); 2) minimal stubble cultivation (MT); 3) no tillage (NT) and two sowing machines: 1) strip tillage and seeding (STS); and 2) direct seeding (DS). The research field plan is presented in Fig. 1.

DS	STS	DS	STS	STS	DS
CT		MT		NT	

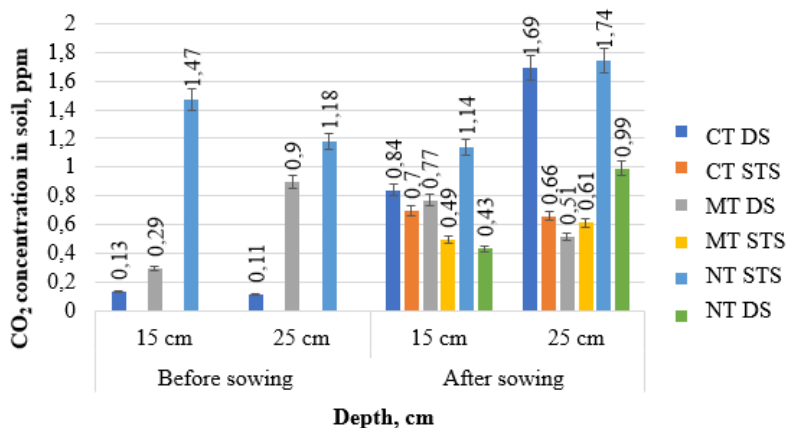
**Figure 1** Field plan for experimental research  
(CT – conventional tillage with ploughing; MT – minimal stubble cultivation;  
NT – no tillage; DS – direct seeding; STS – strip tillage and seeding)

CO<sub>2</sub> concentration in soil (ppm) were measured in each experimental plot, in 4 places, at every 20 m. CO<sub>2</sub> concentration was measured in 15 and 25 cm depth of soil with a Honold G200–X gas analyzer. Soil density, moisture content, and porosity were determined by weighing samples from the 0–10 and 10–20 cm soil layers using a Nekrasov drill and drying in a drying chamber to constant weight. In experiment two sowing machines were used: 1) Mzuri Pro-Till strip tillage and seeding machine; 2) Vaderstad direct seed drill. In the statistical analysis for average indices standard error calculated.

## RESULTS AND DISCUSSION

### *Impact of tillage on CO<sub>2</sub> concentration in soil*

Different tillage practices have different effects on soil temperature. One of the indicators characterizing the soil is the temperature of its surface and surface layers (Mačiulytė and Rimkus, 2016). Moreover, it has influence on CO<sub>2</sub> emissions and its concentration in the soil.



**Figure 2** Changes of CO<sub>2</sub> concentration in soil before and after sowing (CT – conventional tillage with ploughing; MT – minimal stubble cultivation; NT – no tillage; DS – direct seeding; STS – strip tillage and seeding; Error bars indicate the standard error.)

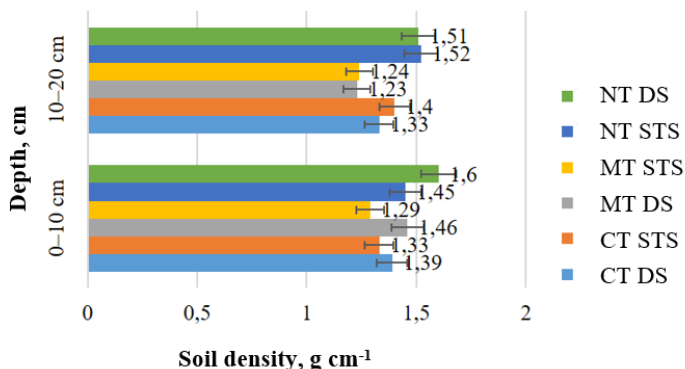
The results of the environmental impact studies showed that after sowing, the concentration of CO<sub>2</sub> in the soil varied the most in the CT soil. The concentration of CO<sub>2</sub> at a depth of 25 cm CT soil varied from 0.11 ppm up to 1.69 ppm when applying DS, while the concentration of CO<sub>2</sub> when applying STS was lower – 0.66 ppm (Fig. 2). However, it can be observed that in the deeper layer of the MT soil the level of CO<sub>2</sub> decreased after sowing, both with the direct sowing and strip sowing, compared to the amount of CO<sub>2</sub> in the MT soil before sowing.

### *Soil density, porosity, moisture*

The results of the conducted research showed that the density of the soil was optimal for the growth of winter wheat both in strip and direct sowing, when soil was conventionally ploughed (CT) or minimally cultivated (MT). However, in the plots of uncultivated soil (NT) both in the case of DS (at 0–10 cm – 1.60 g cm<sup>-3</sup>, and at 10–20 cm – 1.51 g cm<sup>-3</sup>) and in the case of STS (at 0–10 cm – 1.45 g cm<sup>-3</sup>, and at 10–20 cm – 1.52 g cm<sup>-3</sup>) soil density exceeded optimal plant growth conditions for winter crops, which should be 1.30–1.40 g cm<sup>-3</sup> (Fig. 3).

According to the obtained data, the maximum soil aeration porosity was reached at later periods of growing season, i.e. in 15 June, 2021 (Fig. 4). In all periods, in all experimental plots, the highest soil aeration porosity was obtained in soil where strip tillage and seeding (STS) was applied, except DS in conventional tillage with ploughing (CT) in 15 June, 2021.

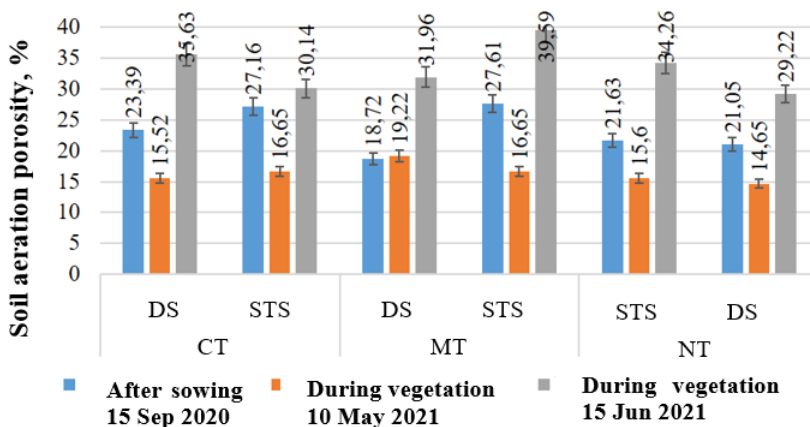
The most favourable soil aeration conditions occur when the total porosity is approximately 50–60% of the soil volume. Critical soil aeration porosity for plant growth is 10% (Arvidsson, 2010).



**Figure 3** Soil density, g cm<sup>-3</sup>

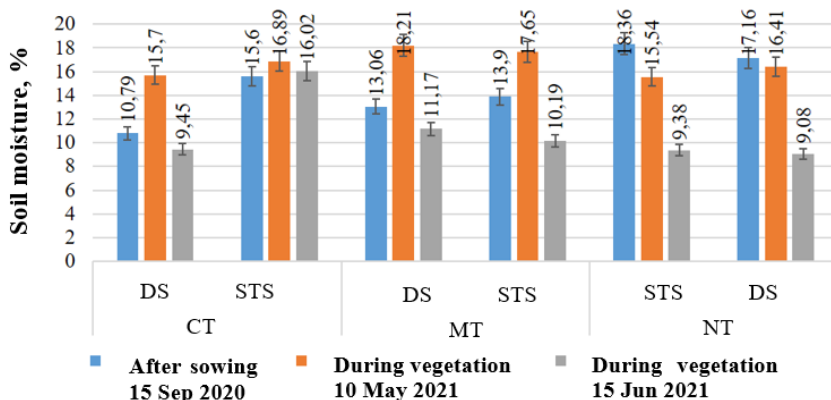
(CT – conventional tillage with ploughing; MT – minimal stubble cultivation; NT – no tillage; DS – direct seeding; STS – strip tillage and seeding; Error bars indicate the standard error.)

After analysing the obtained data, it was found that the highest amount of moisture in the soil during the research period was after sowing, using strip tillage and seeding in NT (18.36%) (Fig. 5). Higher moisture content was found after sowing and during all vegetation in soil where strip tillage and seeding was used in CT than when DS was used.



**Figure 4** Soil aeration porosity, %.

(CT – conventional tillage with ploughing; MT – minimal stubble cultivation; NT – no tillage; DS – direct seeding; STS – strip tillage and seeding; Error bars indicate the standard error.)

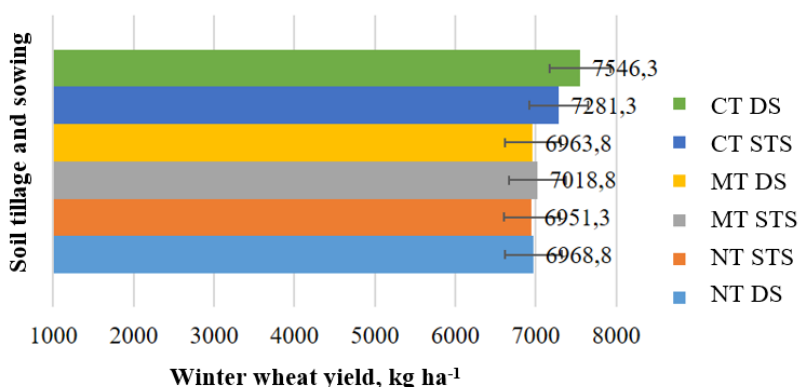


**Figure 5** Moisture variation at a depth of 0–10 cm of soil.

(CT – conventional tillage with ploughing; MT – minimal stubble cultivation; NT – no tillage; DS – direct seeding; STS – strip tillage and seeding; Error bars indicate the standard error.)

### Winter wheat yield

The yield of agricultural plants depends on many factors, but one of the most important is the tillage system (Velykis and Satkus, 2012). After analysing the obtained research results (Fig. 6), it was found that the highest yield (7546.3 kg ha<sup>-1</sup>) was obtained from NT by applying direct sowing. The lowest yield (6951.3 kg ha<sup>-1</sup>) was obtained using the CT and strip tillage and seeding.



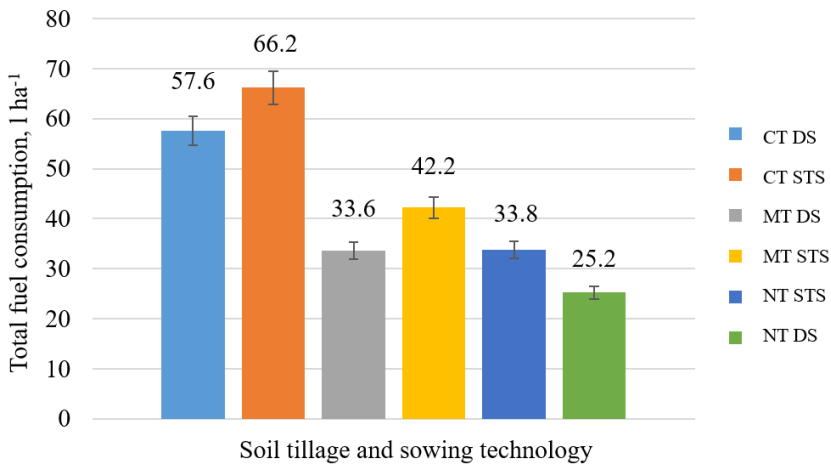
**Figure 6** Winter wheat yield, 2021.

(CT – conventional tillage with ploughing; MT – minimal stubble cultivation; NT – no tillage; DS – direct seeding; STS – strip tillage and seeding; Error bars indicate the standard error.)

Very similar results were obtained with the application of the STS and minimal stubble cultivation (6963.8 kg ha<sup>-1</sup>), as well as with the application of the DS and the conventional tillage with ploughing (6968.8 kg ha<sup>-1</sup>).

### **Fuel consumption**

Evaluating the total fuel consumption, it can be seen that the highest fuel consumption was obtained in CT STS (66.2 L ha<sup>-1</sup>), and the lowest in NT DS (25.2 L ha<sup>-1</sup>), i. e. more than half lower. It was also observed that, regardless of the soil preparation method, strip tillage and seeding machine resulted in higher fuel consumption than the direct seeding machine (Fig. 7).



**Figure 7** Total fuel consumption in different agrotechnologies, 2020–2021. (CT – conventional tillage with ploughing; MT – minimal stubble cultivation; NT – no tillage; DS – direct seeding; STS – strip tillage and seeding; Error bars indicate the standard error.)

Research results show that soil tillage technology using a plough is expensive and requires high fuel consumption and costs for technological processes. From the economic point of view, the most favourable for the farmer is the no tillage technology using direct seeding (NT DS).

According to Beinor and Vanag (2022), using no-till technology in farms reduces fuel consumption by 44% compared to ploughed tillage technology, moreover it results in approximately 40% less greenhouse gas emissions. Furthermore, when using no-till farming technology, the time required for technological operations is reduced by 30% compared to tillage technology with ploughing.

## CONCLUSIONS

Lower CO<sub>2</sub> concentration of 0.99 ppm in the soil was found in the NT DS treatment than in the TN STS (1.14 ppm).

In the plots of uncultivated soil (NT) both in the case of DS and STS and MT DS soil density was higher than in CT. The highest soil aeration porosity was obtained in soil where strip tillage and seeding (STS) was applied, except DS in conventional tillage with ploughing (CT) at later stages of winter wheat vegetation.

The highest amount of moisture in the soil during the research period was after sowing, using strip tillage and seeding in NT (18.36%). Higher moisture content was found after sowing and during all vegetation in soil in CT with strip tillage and seeding with DS.

Reduced tillage had a positive influence on the yield of winter wheat, a higher yield was obtained when applying NT STS – 7281.3 kg ha<sup>-1</sup>, than when applying the CT STS – 6951.3 kg ha<sup>-1</sup>.

The highest total fuel consumption (66.2 L ha<sup>-1</sup>) and the total costs of technological processes (202.8 Eur ha<sup>-1</sup>) were determined when applying conventional tillage and the technological operation of strip sowing (CT STS), and the lowest, respectively, 25.2 L ha<sup>-1</sup> and 202.8 Eur ha<sup>-1</sup> – when applying direct sowing in uncultivated soil (NT DS).

## ACKNOWLEDGMENT

The authors want to express their appreciation to Experimental Station of Vytautas Magnus University Agriculture Academy.

## REFERENCES

- Al-Mansour F., Jecic V. (2017). A model calculation of the carbon footprint of agricultural products: The case of Slovenia. *Energy* 136: 7-15.
- Arlauskas M. (1994). Minimization of tillage. *Agricultural Sciences* 1: 39-43.
- Arvidsson J. (2010). Energy use efficiency in different tillage systems for winter wheat on a clay and silt loam in Sweden. *European Journal of Agronomy* 33(3): 250-256.
- Avižienytė D. (2013). Long-term impact of different tillage on agroecosystem by applying intensive technologies and plant change: Doctoral Thesis. Akademija, Lithuania
- Buragienė S., Šarauskis E., Romaneckas K., Sakalauskas A., Užupis A., Katkevičius E. 2011. Soil temperature and gas emissions from soils under different tillage machinery systems. *Journal of Food, Agriculture and Environment* 9: 480-485.
- Feizienė D., Feiza V., Kadžienė G., Vaidelienė A., Povilaitis V., Deveikytė I. (2012). CO<sub>2</sub> fluxes and drivers as affected by soil type, tillage and fertilization. *Acta Agriculturae Scandinavica, Section B - Soil and Plant Science* 62(4): 311-328.
- Jodaugienė D. (2002). The influence of long-term ploughing and cultivation on soil and crops of agricultural plants in the system of reduced tillage: summary of doctoral dissertation. Akademija, Lithuania.
- Konstantinavičiūtė I., Byčenkienė S., Kavšinė A., Smilgius T., Zaikova I., Juška R., Žiukelytė I., Lenkaitis R., Juraitė T., Kazanavičiūtė V., Jezukevičius S., Tijūnaitė R., Kairienė E., Kavšinė A.,



- Žiukelytė I., Merkelienė J., Čeicytė L. (2017). Lithuania's national inventory report 2017 greenhouse gas emissions (1990-2015).
- Mačiulytė V., Rimkus E. (2016). Soil thermal regime in Lithuania. *Geology* 2(1):1-13.
- Maikštėnienė S., Šlepetienė A., Masilionytė L. (2007). Effects of rotary and non-rotary main tillage on the properties of gleyic cambisols and energy efficiency of agrosystems. *Agriculture* 94(1): 3-23.
- Mugauskiene V. (2017). *Agroakademija: The threat of erosion to our soils.*
- Pandey D., Agrawal M. (2014). Carbon footprint estimation in the agriculture sector. In *Assessment of Carbon Footprint in Different Industrial Sectors, Volume 1*, Springer, Singapore, 25-47.
- Reicosky D. C., Archer D.W. (2007). Moldboard plow tillage depth and short-term carbon dioxide release. *Soil and Tillage Research* 94: 109-121.
- Rusu T. (2014). Energy efficiency and soil conservation in conventional, minimum tillage and no-tillage. *International Soil and Water Conservation Research* 2(4): 42-49.
- Singh K.P., Prakash V., Srinivas K., Srivastva A.K. (2008). Effect of tillage management on energy-use efficiency and economics of soybean (*Glycine max*) based cropping systems under the rainfed conditions in North-West Himalayan Region. *Soil and Tillage Research* 100(1-2): 78-82.
- Son, P., Taewichit C., Salokhe V. M. (2013). Energy consumption and CO<sub>2</sub> emissions in rainfed agricultural production systems of Northeast Thailand. *Agricultural Systems* 116: 25-36.
- Sørensen C. G., Halberg N., Oudshoorn F. W., Petersen B. M., Dalgaard R. (2014). Energy inputs and GHG emissions of tillage systems. *Biosystems Engineering* 120: 2-14
- Steponavičienė V. (2017). Sustainability of agroecosystems and carbon accumulation in the soil by applying long-term complex measures: Doctoral Thesis. *Akademija, Lithuania.*
- Velykis A., Satkus A. (2012). Influence of reduced tillage of heavy loams on spring barley weediness and yield. *Agricultural sciences* 19(4): 236-248

---

---



## STABILITY ANALYSIS OF A TRAILED FARM SPRAYER AGGREGATE BY SIMULATION MODEL

Nicolae LONTIS, Gabriel MALAIMARE, Dumitru TUCU\*

\*E-mail of corresponding author: dumitru.tucu@upt.ro

*Mechanical Machines and Transportation, Politehnica University Timisoara,  
No.1, Mihai Viteazu Av., RO-300011 Timisoara, Romania*

### ABSTRACT

*The trailed farm sprayers became important equipment in weed control, especially in mico-, small and middle farms. Thanks to their reliability and efficiency it can cover the needs of every farmer. An important problem is the stability of the aggregate, even on the apparent flat surfaces, because aggregate has no suspension system. The paper presents a simulation model for analyse the dynamics and stability of trailed farm sprayer aggregate used in agriculture on the flat field, based on commercial soft Virtual CRASH 4. The simulation model analyses the stability of the aggregate composed by Maschio Gaspardo Campo CX P32, 3000 litre, and tractor CLASS ARION Serie 460 on a flat land (cultivated land), scanned by drone DJI Mavic Pro2. The displacement was considered at 1,4 m/s; 2,8 m/s; and 4,2 m/s. A suddenly ditch with variable deep were considered at four levels 0,25 m, 0,2 m, and 0,15 m. Three steering angle situations were considered: 30, 20 and 10 degrees. During the experiments the tank was considered 60 % filled. After simulation, based on presented model, next recommendations are presented: during weeding control activities (spraying), the operator must be carefully to the land conditions and permanently adapt the tractor speed and steering angle to them. A special mention must be the operator to keep in mind the filled level of the tank and correlate the displacement speed between different crop zones as workplaces. Such procedures generated by present simulation model must be integrated with other elements of modern agriculture.*

**Keywords:** *stability analysis, trailed farm sprayer, simulation model, land conditions*

### INTRODUCTION

Almost in agricultural crops site-specific weed control offers a substantial potential for herbicide savings, without causing yield losses or ecological accidents and additional weed management costs (Allmendinger et al., 2022). Therefore, a complex of research activities

approaches the many problems regarding different topics of plant protection products applied by agricultural sprayers. Even the public beneficiaries are interested on the influences of plant protection activities on the crop (Pikuła and Rutkowska, 2014; Beres, 2016; Hurej et al., 2017; Zarzyńska et al., 2017), almost attention is concentrated on chemical pest control (Matyjaszyk, 2017). Optimization of plant protection process, firstly, supposes the herbicide savings by limited to the necessary extent by using of Variable-rate Sprayers (Chen et al., 2021) or other Precision Chemical Weed Management Strategies: robots and automation (Lowenberg-DeBoer et al., 2020), real-time precision spraying (Zanin et al., 2022), etc. Less studies approach the accidents which spread in the same place a lot of herbicides. Such problems became interesting in conditions of law qualification, perception, and motivation regarding risk of accident in agriculture (Tucu et al., 2021; Tucu et al., 2019). The actual question is if the current state of the art of weed control is suitable for site-specific weed management in arable crops (Fernández-Quintanilla et al., 2018), in conditions of missing inspection regarding the sprayer's stability (Tadic et al., 2021).

The paper presents the results regarding analysis of the trailed farm sprayer stability when the aggregate (tractor + sprayer) makes a U turn at the end of the crop field, using a simulation model based on commercial soft Virtual CRASH 4.0 in field conditions modelled using high resolution aerial photos captured by DJI MAVIC Pro 2 Drone.

## MATERIAL AND METHODS

The software used for performing virtual experiments was a commercial version licensed by dongle key - Virtual CRASH 4.0. The simulation model analyzed the stability of the trailed farm sprayer when the aggregate makes a U turn at the end of the crop field, continuing with the land treatment in the opposite direction (180°). The proposed model is composed by a tractor (Class Arion 460, 135 HP (main specifications in table 1)) and steered trailed farm sprayer with prow and one axes, manufactured by MASCHIO GASPARDO (specifications presented in table 2).

**Table 1** Class Arion 460 specifications

No.	Specification	Value(s)
1	Length, [m]	4.910
2	Width, [m]	3.110
3	Height, [m]	3.165
4	Wheelbase, [m]	2.890
5	Track width rear, [m]	2.370
6	Track width front, [m]	2.200
7	Front tires	550R22
8	Rear tires	650R35
9	Mass, [kg]	5200

**Table 2** Trailed farm sprayer Gaspardo CAMPO C32 specifications

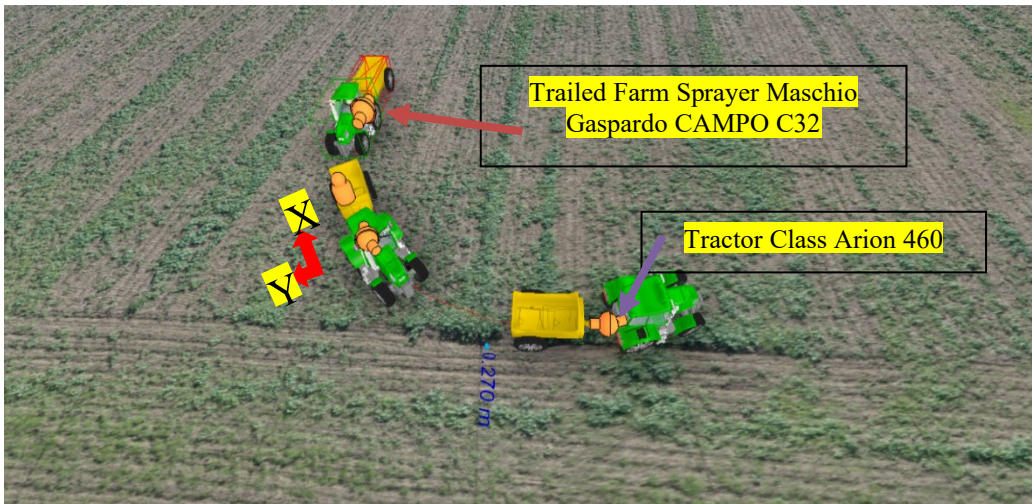
No.	Specification	Values
1	Length, [m]	5.000
2	Width, [m]	2.365
3	Height, [m]	2.303
4	Overhang, [m]	4.100
5	Track width, [m]	2.250
6	Tyres	270/95 R48
7	Mass, [kg]	4680

The crop field was modeled in Virtual CRASH 4.0 software using high resolution aerial photos captured by DJI MAVIC Pro 2 Drone, with a 20-million-pixel camera.

The following hypothesis were considered during the simulation's operations:

- The computational method of the Virtual CRASH 4.0 is full integration with integrations step of 0.005 s and pre-calculated of 1.000 s.
- The trailed farm sprayer load is stable - the center of gravity does not change.
- The surface of the field is dry value of the coefficient of friction is 0,7.
- The aggregate will make a U turn at the end of the field crossing the sudden ditch.

The complete model developed in Virtual CRASH 4.0 and run-in simulations is presented in figure 1. The simulations computed in Virtual CRASH 4.0 were performed on a flat crop field while the assembly makes a U turn at the end of the crop field in order to treat the rest of the field in the opposite direction when a sudden ditch is crossed and after the left wheel of the trailed farm sprayer meets the bottom of the ditch, and for a time fraction the wheel is placed inside the ditch along with the bed. For the present study 3 sudden ditches were proposed with deeps varying from 0.15 m, 0.20 m and 0.25 m. The width of the bottom of the ditch was 0.270 m. During the simulations then different steer angles of Tractor were applied 10, 20 and 30 degrees. The simulations were run for the specific assembly (tractor and steered trailed farm sprayer) at three speeds (1.4, 2.8 and 4.2 m/s).



**Figure 1** The complete model developed

The following hypothesis were considered during the simulation's operations:

- The computational method of the Virtual CRASH 4.0 is full integration with integrations step of 0.005 s and pre-calculated of 0.050 s.
- The steered trailed farm sprayer load is 60 % of the total tank capacity  $V_{\max} = 3000$  l.
- The crop field is dry – the value of the coefficient of friction is 0.7.
- The center of gravity of the Trailed Farm Sprayer is moving along the y and z axes.

For results analysis was used the factorial experiment method (Lontis et al., 2021). After simulation resulted the mathematical model. Also, was evaluated the concordance between the obtained objective function from the experimental tests and the values estimated by the mathematical model. Finally, the reciprocal influences between the factors were evaluated.

## RESULTS AND DISCUSSION

In table 3 are described the results of simulations. The position of trailed farm sprayer had the next levels: crossing; trip; slight difficulty in crossing needs more speed to take out the trailed farmed sprayer from the ditch, marked as „+“; difficulty in crossing needs more speed to take out the Tractor from the ditch, marked as „++“; tilting the Trailed farm sprayer when crossing the ditch, marked as „+++“; tilting the Trailed farm sprayer before crossing the ditch, marked as „++++“”. The displacement of center of gravity (CG) – on y axis was also considered.

**Table 3** Results of the simulations

No.	Speed [m/s]	Ditch depth, [m]	Tractor steering angle, [°]	Trailed farm sprayer CG displacement on y axes, [m]	Trailed farm sprayer position
1			10	0.058	crossing
2	1.4	0.15	20	0.074	crossing
3			30	0.081	crossing
4			10	0.118	crossing
5	1.4	0.20	20	0.162	crossing
6			30	0.204	crossing
7			10	0.182	crossing
8	1.4	0.25	20	0.257	+
9			30	0.334	++
10			10	0.343	crossing
11	2.8	0.15	20	0.365	crossing
12			30	0.382	crossing
13			10	0.420	crossing
14	2.8	0.20	20	0.475	crossing
15			30	0.521	crossing
16			10	0.500	crossing
17	2.8	0.25	20	0.584	+
18			30	0.662	++
19			10	0.624	crossing
20	4.2	0.15	20	0.654	crossing
21			30	0.687	crossing
22			10	0.720	crossing
23	4.2	0.20	20	0.781	crossing
24			30	0.836	crossing
25			10	0.821	+++
26	4.2	0.25	20	0.904	++++
27			30	0.987	<b>Trip</b>

The number of levels,  $p$ , were maxim and minim ( $p=2$ ), and the number of factors,  $k=3$ , thus resulting a minimum number of experiments in revealing important conclusions,  $N : N = 2^3 = 8$ .

Because the input parameters (factors) for the mathematical model were:

- $X_1 =$  Assembly speed,  $v$ , [km/h];
- $X_2 =$  Ditch depth,  $h$  [m];
- $X_3 =$  Tractor steering angle,  $\alpha$ , [degrees],

the established resulted levels of each factor and their specific range of variation (lower level, central point and higher level), are shown in table 4.

**Table 4** Values of the input parameters

Name/Code	Parameters	Speed [m/s]	Ditch depth [m]	Tractor steering angle $\alpha$ [°]
Base level, <b>0</b>	$X_0$	2.8	0.20	20
Lower level, <b>-1</b>	$X_1$	1.4	0.15	10
Higher level, <b>+1</b>	$X_s$	4.2	0.25	30
Variation	$\Delta X$	$\pm 1.4$	$\pm 0.05$	$\pm 10$

The program matrix with adjustable parameters (lower and upper level) related to the simulated conditions of movement of the assembly is presented in table 5.

The output parameter of the system, taken into analysis, was **Trailed farm sprayer CG on y axes displacement, Y [m]**, representing the sliding displacement of trailer relative to initial position. The program matrix of the mathematical model is presented in table 6.

**Table 5** The program matrix with adjustable parameters while the assembly is moved

No.	Speed [m/s]	Ditch depth [m]	Tractor steering angle [°]
1	1.4	0.15	10
2	4.2	0.15	10
3	1.4	0.25	10
4	4.2	0.25	10
5	1.4	0.15	30
6	4.2	0.15	30
7	1.4	0.25	30
8	4.2	0.25	30

**Table 6** Matrix program with coded parameters for the assembly

No.	$X_0$	$X_1$	$X_2$	$X_3$
1	1	-1	-1	-1
2	1	+1	-1	-1
3	1	-1	+1	-1
4	1	+1	+1	-1
5	1	-1	-1	+1
6	1	+1	-1	+1
7	1	-1	+1	+1
8	1	+1	+1	+1

Using the regression coefficients calculated (table 7), the resulted mathematical model was:

$$Y_c = 0,472 + 0,308 \cdot X_1 + 0,109 \cdot X_2 + 0,051 \cdot X_3 + 0,015 \cdot X_1 \cdot X_2 + 0,007 \cdot X_1 \cdot X_3 + 0,029 \cdot X_2 \cdot X_3 - 0,003 \cdot X_1 \cdot X_2 \cdot X_3$$

**Table 7** The regression coefficients calculated

b <sub>0</sub>	b <sub>1</sub>	b <sub>2</sub>	b <sub>3</sub>	b <sub>12</sub>	b <sub>13</sub>	b <sub>23</sub>	b <sub>123</sub>
0.472	0.308	0.109	0.051	0.015	0.007	0.029	-0.003

Table 8 presents the results calculated for control the concordance between the real values simulated, obtained from the experimental tests (column Y) and the values calculated by the application of mathematical model (column Yc).

**Table 8** Control of the concordance between the function objective and the mathematical model

No.	X <sub>0</sub>	X <sub>1</sub>	X <sub>2</sub>	X <sub>3</sub>	Y	Yc	ΔY [%]
1	1	-1	-1	-1	0.058	0.058	0.000
2	1	+1	-1	-1	0.624	0.624	0.000
3	1	-1	+1	-1	0.182	0.182	0.000
4	1	+1	+1	-1	0.821	0.820	0.122
5	1	-1	-1	+1	0.081	0.082	-1.235
6	1	+1	-1	+1	0.687	0.688	-0.146
7	1	-1	+1	+1	0.334	0.334	0.000
8	1	+1	+1	+1	0.987	0.988	-0.101

The R-Squared statistic calculated by STATEGRAPHIC Centurion XVI justify that the model as fitted explains 99.9996% of the variability. The standard error of the estimate shows the standard deviation of the residuals to be 0.000763751. The obtained model permits to calculate (to predict) the displacement of CG on Y axis (transversal) for a trailed sprayer, as function on Assembly speed, v (X1), Ditch depth, h (X2) and Tractor steering angle, α (X3). Such mathematical model can be applied in integrated solutions for digitalize the weed control agrotechnics with agricultural aggregate or/and other systems in different solutions and conditions (Hu et al., 2021; Crisan et al., 2017). The proposed model and analysis did not considered the influences on stability of liquid sloshing. For such solutions an integrated model cumulating the equivalent mechanical at model of liquid sloshing must be used. A multi-degree-of-freedom model of the sprayer chassis that includes the effect of liquid sloshing could be transferred from Zheng et al. (2022).



## CONCLUSIONS

Consulting the simulations results, a first conclusion is the displacement of trailed sprayer must be carefully, with attention at ditch's depth, because even at low depth if the speed is not adequate on the tank fulfilling, the aggregate stability could be lost. Also, special attention must be assigned to the surface of the field (if the surface is not dry, the coefficient of friction decrease, also the land stability). The proposed mathematical model could be applied to predict the safety displacement of aggregate including trailed sprayer and tractor on dry surfaces on the lands with ditches for obtaining the correct trajectory and speed, especially at the end of land during turning on „U”. Future research must consider different initial conditions regarding friction coefficient (different soil moisture values) and built up a four variable prediction model. Also, influences on high (Z axis) must be considered in the displacement at speed value more than 2.4 - 3 m s<sup>-1</sup>.

The procedures generated using present simulation model must be integrated with other elements of remote/digital agriculture.

## REFERENCES

- Allmendinger, A., Spaeth, M., Saile, M., Peteinatos, G.G., Gerhards, R. (2022) Precision Chemical Weed Management Strategies: A Review and a Design of a New CNN-Based Modular Spot Sprayer. *Agronomy*, 12, 1620. <https://doi.org/10.3390/agronomy12071620>
- Bereś, P. K. (2016). Efficacy of spinosad and *Bacillus thuringiensis* var. *kurstaki* in biological control of the european corn borer on sweet corn. In: *Acta Scientiarum Polonorum-Hortorum Cultus*, Vol. 15(6), 19-35
- Chen, L.M., Zhu, H.P., Horst, L., Wallhead, M., Reding, M., Fulcher, A. (2021). Management of Pest Insects and Plant Diseases in Fruit and Nursery Production with Laser-guided Variable-rate Sprayers. *Hortscience*, Vol. 56 (1), 94-100
- Crisan, G.C., Tucu, D., Boboescu, R. (2017). Improvement of safe & healthy work systems in agricultural SME's. In: *Actual Tasks on Agricultural Engineering-Zagreb*, vol.45, 657-663
- Fernández-Quintanilla, C., Peña, J.M., Andújar, D., Dorado, J., Ribeiro, A., López-Granados, F. (2018). Is the current state of the art of weed monitoring suitable for site-specific weed management in arable crops? *Weed Res.*, 58, 259-272
- Hu, D., Pei, Z., Tang, Z. (2021). Automatic Control Optimization for Large-Load Plant-Protection Quadrotor. *Appl. Sci.*, 11, 4058. <https://doi.org/10.3390/app11094058>
- Hurej, M., Kucharczyk, H., Twardowski, J.P., Kotecki, A. (2017). Thrips (Thysanoptera) associated with two genetically modified types of linseed (*Linum usitatissimum* L.). *Journal of Plant Diseases and Protection*, Vol. 124 (1), 81-91
- Lontis, N., Tucu, D., Malaimare, G., Groza, I.V. (2021). Simulation model of agricultural transport units behaviour on public roads. In: *Book Series: Actual Tasks on Agricultural Engineering, Zagreb*. Vol.48, 493-500
- Lowenberg-DeBoer, J., Huang, I., Grigoriadis, V., Blackmore, S. (2020). Economics of robots and automation in field crop production. *Precision Agric.* 21, 278-299
- Matyjaszczyk, E. (2017). Use of active substance depending of the formulation of plant protection products applied with agricultural sprayers. A case study of winter wheat in Poland. In: *9th International Scientific Symposium on Farm Machinery and Process Management in Sustainable Agriculture*, Lubin, Poland, 228-232,

- [https://depot.ceon.pl/bitstream/handle/123456789/14808/FMPMSA2017\\_228Matyjaszczyk.pdf?sequence=1&isAllowed=y](https://depot.ceon.pl/bitstream/handle/123456789/14808/FMPMSA2017_228Matyjaszczyk.pdf?sequence=1&isAllowed=y), accessed October 2022
- Pikuła, D., Rutkowska, A. (2014). Effect of leguminous crop and fertilization on soil organic carbon in 30-years field experiment. *Plant, Soil and Environment*, Vol. 60 (11), 507-511
- Tadić, V., Banaj, Đ., Knežević, D., Banaj, A., Petrović, D., Sabljak, J. (2021). Technical inspection of crop protection machines according to HRN EN ISO 16122:2015. In: *Book Series: Actual Tasks on Agricultural Engineering-Zagreb*, vol.48, 401-408
- Tucu, A., Purcarea, A.A., Crisan, G.C., Vasilica, A., Tucu, D. (2021). Quality evaluation of occupational health & safety (OHS) risk management systems from agriculture. In: *Book Series: Actual Tasks on Agricultural Engineering-Zagreb*, vol.48, 527-534
- Tucu, D., Crisan, G.C., Tucu, A. (2019). The use of self-assessment in occupational risk management system in SMEs from agriculture. In: *Book Series: Actual Tasks on Agricultural Engineering-Zagreb*, vol.47, 479-485
- Zanin, A.; Neves, D.; Teodora, L.; Silva Junior, C.; Silva, S.; Teodora, P.; Baio, F. (2022). Reduction of pesticide application via real-time precision spraying. *Sci. Rep.* 12, 5638. <https://doi.org/10.1038/s41598-022-09607-w>
- Zarzyńska, K., Boguszewska-Mańkowska, D., Nosalewicz, A. (2017). Differences in size and architecture of the potato cultivars root system and their tolerance to drought stress. *Plant, Soil and Environment*, Vol. 63 (4), 159-164
- Zheng, J., Li, Y., Zhang, L., Xue, X. (2022). Analysis of roll stability of the sprayer based on the equivalent mechanical model of liquid sloshing. *INMATEH - Agricultural Engineering*, Vol. 67, No. 2, 106-116



## EVALUATION OF AIR FLOW INFLUENCE ON SPRAYER NOZZLE PERFORMANCE BY SHADOWGRAPHY

Lorenzo BECCE<sup>1,2\*</sup>, Giovanni CARABIN<sup>2</sup>, Fabrizio MAZZETTO<sup>1,2</sup>

\*E-mail of corresponding author: lorenzo.becce@unibz.it

<sup>1</sup>Competence Centre for Plant Health, Free university of Bozen-Bolzano (UNIBZ), Italy

<sup>2</sup>Faculty of Science and Technology (Fa.S.T.), Free university of Bozen-Bolzano (UNIBZ), Italy

### ABSTRACT

*Effective crop protection is strongly dependent on proper calibration of the machines. An important performance parameter is the drop size distribution of the single nozzle, which is usually evaluated in dedicated test stands, separate from the machine. This raises the question of how said performances change once the nozzle is mounted on the machine. Well-known nozzle analysis techniques such as Particle/Droplet Image Analysis (PDIA) can both answer this question and aid in calibrating the machine in its working configuration. This work compares droplet statistics of a nozzle by laser shadowgraphy, a PDIA technique, in a dedicated test bench and on an orchard airblast sprayer, studying the effect of air assistance and laying the groundwork for the development of an automated calibration protocol for sprayers, which foresees scanning the whole distribution pattern of the machine to evaluate the uniformity of distribution. Air-inclusion flat-fan were tested by a VisiSize N60V by Oxford Lasers on an orchard airblast sprayer at three fan gear ratios (idle, low, high). The instrument was positioned in front of the sprayer and, under the same conditions, in a dedicated test bench to evaluate the same nozzles. The influence of airspeed on average droplet parameters (volume percentiles and mean velocities) is examined, prompting a brief discussion of the mechanisms involved. The next steps foresee gathering further data to refine the methodology.*

**Keywords:** *crop protection, airblast sprayer, Particle/Droplet Image Analysis, sprayer calibration, droplet size distribution*

### INTRODUCTION

Due to the relevance of fruit and wine grape production for the local economy (Tappeiner et al., 2020), plant protection treatments are frequent and raise concerns among the general public, in particular regarding the problem of atmospheric drift. This phenomenon, together

with orchard sprayer performance, is at the centre of a recently launched research activity at the Agroforestry Innovation Laboratory (AFI-Lab) of the Free University of Bozen-Bolzano (unibz, Italy).

The proper calibration of orchard sprayers is fundamental in ensuring effective treatments and in reducing product losses to the environment. In particular, in order to properly set the machine up for field operation, the performance of every single nozzle employed, in terms of droplet size distribution (DSD) and relevant droplet statistics, has to be known beforehand. The strategies to analyse single nozzles in dedicated test stands, separate from the target machine, are many and well proven: (Pascuzzi et al., 2021) provided a brief review of the most common techniques. How said performances change once the nozzle is inserted in the machine and cooperates with the rest of the system is an interesting question per se; answering it may open the possibility to use well-known nozzle analysis techniques to calibrate the machine in its working configuration, an idea which has been preliminarily validated by (Pascuzzi & Mazzetto, 2021).

The presented work compares droplet statistics of a nozzle by laser shadowgraphy, also known as Particle/Droplet Image Analysis (performed by a VisiSize N60V, Oxford Lasers) in a dedicated nozzle test bench and on an orchard airblast sprayer, studying in particular the effect of air assistance. Interesting studies on PDIA have been carried out, for example, by (Castanet et al., 2013; Minov et al., 2016).

Three samples of an air-inclusion flat-fan nozzle (Albuz CVI80-01, Solcera, France) were tested in a dedicated test bench and on a Caffini Synthesis 1000 (Caffini s.p.a., Palù, VR, Italy) at three fan gear ratios (idle, low, high) at 3 bar pressure, replicating the conditions as best as possible. The shadowgraph is positioned in front of the sprayer at fixed height above the ground. Correlations of average droplet parameters (volume percentiles) are drawn with respect to airspeed and between the two setups (machine and test bench), prompting a brief discussion of the mechanisms involved.

A further aim of this work is to develop the methodology for an automated calibration protocol for orchard sprayers, evaluating the uniformity of distribution by scanning the whole distribution pattern of the machine.

A similar work has been carried out by (Balsari et al., 2019), yet on pneumatic sprayers, which work according to a totally different principle and the liquid breakup into droplets takes place thanks to the airflow in which the nozzle is dipped.

The next steps in the work involve gathering further data from more nozzle specimen and types in order to refine the methodology. The document is closed with a description of the instrument to be developed to conduct the automated test and the research possibilities enabled by such a tool.

## **MATERIALS AND METHODS**

### ***Generalities***

Three specimens of the same nozzle type were characterized by shadowgraphy in a dedicated test bench and then on a Caffini Synthesis 1000 orchard airblast sprayer. The nozzle is a CVI80 by Albuz, ISO class 01 (orange), operated with tap water.

The performance parameters considered are the three main volume percentiles (DV10, DV50 or Volume Median Diameter (VMD), DV90), and the average speed of the droplets. An extensive explanation on these parameters can be found in chapter 3 of (Lefebvre & McDonell, 2017).

### ***The shadowgraph***

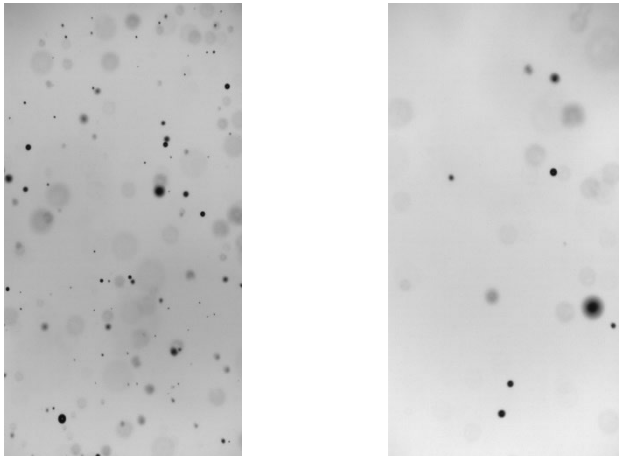
The shadowgraph, a Particle/Droplet Image Analysis system (PDIA): the VisiSize N60 by Oxford Lasers (Didcot, Oxfordshire, UK). In short, it is composed of a light diffuser which pulsates light against a camera. By analysing the shadows cast by the droplets crossing the camera's field of view, the relevant statistics describing the nozzle performance can be extracted. The authors of (Kashdan et al., 2007) described the inner workings of the algorithm in good detail.

The FOV of the camera, at the standard lens magnification of 0.58 x, is roughly 10.6x18.7 mm. Figure 1 shows two typical images acquired during the tests.

For every nozzle specimen, one acquisitions of about 10000 droplets was carried out, with the centreline of the spray fan aligned to the centre of the camera FOV.

### ***The nozzle test bench***

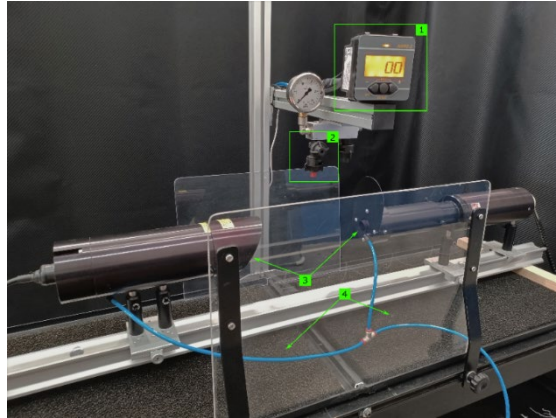
The dedicated nozzle test bench, described in more detail in (Becce et al., 2022), is a custom-built water-recirculating system, which together with the shadowgraph is visible in Fig. 2. The hydraulic circuit is made of a collecting tub, acting as reservoir, from which tap water is drawn and forced by a membrane pump, at the desired pressure, into a conventional nozzle holder facing downwards. The distance between nozzle orifice and optical setup centreline was 50 cm.



**Figure 1** Two shadowgrams collected during the work: left are droplets from a CVI8001 without air assistance, right is the same setting with high fan speed

The pressure is verified by a pressure transducer (Keller PA-22S, 10 bar scale, KELLER Pressure, Wintherthur, Switzerland) connected to a P90 Agro 2 multimeter supplied by

Salvarani s.r.l. (Poviglio, Italy). Its accuracy, limited to 1 decimal position, was verified in a manometer test jack by Salvarani, made of a manual screw jack which applies the same pressure to the sensor under testing and to a reference one (CPG500 digital pressure gauge, 0-60 bar, accuracy 0.25% FS; Wika Alexander Wiegand SE & Co. KG, Germany).



**Figure 2** The nozzle test bench with optical setup. (1) P90 multimeter, (2) nozzle holder, (3) VisiSize N60 optical array, (4) water collection and storage tubs

### ***Testing on the machine***

The test machine was a Caffini Synthesis 1000, an orchard airblast sprayer with ten nozzles per side. For the test, it was powered by the power take-off (PTO) of a New Holland TN75V orchard tractor.

The airblast apparatus was calibrated less than a month before by a special test stand (WP5000, Ernst Herbst Prüftechnik e.K., Hirschbach, Germany) at the sprayer functional control workshop of the South Tyrolean Advisory Centre for Fruit and Grapevine Production (Südtiroler Beratungsring für Obst- und Weinbau/Centro di Consulenza per la fruttivitecologia dell'Alto Adige) in Lana, BZ.

For the calibration, scans of the output airspeed and direction were iterated several times while manually adjusting the outlet duct so as to align and uniform the flow as much as possible. The final configuration sported a 15.6% coefficient of variation (CV) in the volumetric airflow rate, and was deemed satisfactory.

To test the nozzles on the machine, the same three specimen evaluated beforehand were mounted on one of the ten anti-drip nozzle holders (Braglia s.r.l., Reggio Emilia, Italy) available on the right side of the sprayer. All the other holders were turned off, so that the only active nozzle was the one under test, at a height of 105 cm above the ground.

The Wika reference manometer was then mounted at the end of the sprayer's hydraulic circuit to verify its accuracy as well. However, due to the high vibrations of the machine and the coarse control system (a simple hand-operated switch to pilot the pressure regulator), a stable value of 3 bar could not be achieved and the actual value was found to oscillate between 2.70 and 3.80 bar.

The optical setup of the N60 was mounted on a dedicated stand realized out of aluminium structural beams, mounted on lockable wheels for a more accurate positioning of the setup relative to the machine: the distance between the nozzle output and the camera FOV is about 50 cm. The height of the setup was regulated so as to match the centreline of the nozzle, therefore recreating the scenario on the nozzle test bench, except for having the whole system horizontal.

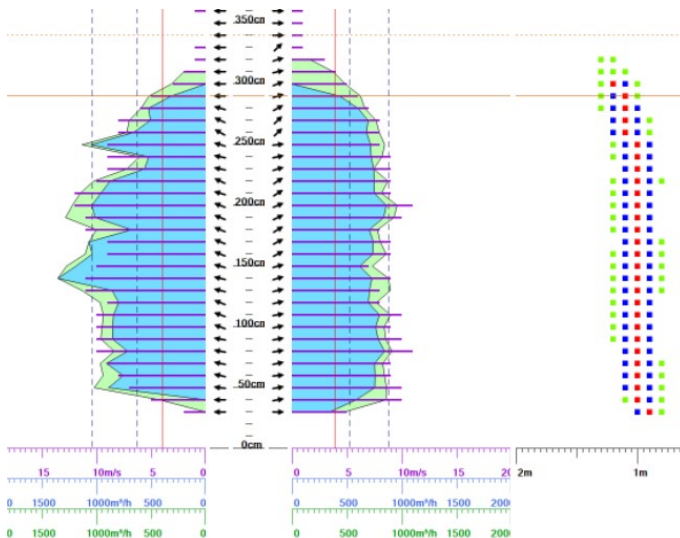
**Software**

The software used to gather and elaborate the data is VisiSize, provided by Oxford Lasers together with the instrument. VisiSize controls the laser and data acquisition and performs the analysis of the raw images: after discarding the shadows that are either out of focus, crossing the image border or too oblate, the pixels composing each of these are counted and, by a pixel-micron factory calibration, the equivalent diameter of the droplet which cast the shadow is estimated. Once the test is complete, an automated report is produced, complete with all the relevant test parameters and accompanied by a text file containing the information for all the successfully captured droplets.

Given the limited size of the data, these were extracted manually from the reports. Larger datasets will be imported and managed with the tools under development as per (Becce et al., 2022), but given the architectural limitations described in the work, a large redesigning effort is necessary and currently being addressed.

**RESULTS AND DISCUSSION**

**Machine Configuration**

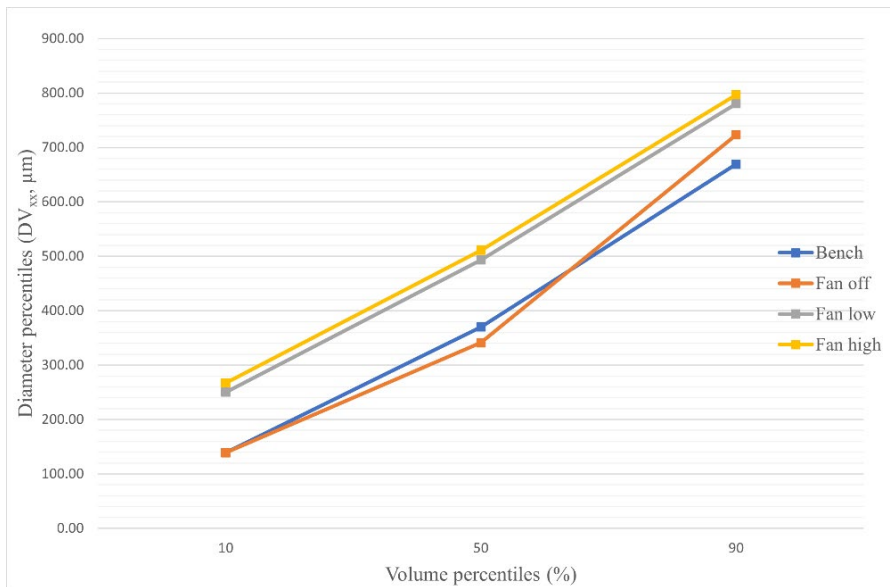


**Figure 3** A portion of the automated test report from the WP5000 air test stand detailing the measured air flow from the two sides of the machine. Notice the non-uniformity of the flow from the left side, which was not yet calibrated.

The WP5000 report in Fig. 3 states that the airstream at 105 cm above ground level has a speed of about 9.5 m s<sup>-1</sup>, with a usable volume rate of about 800 m<sup>3</sup>h<sup>-1</sup> (purple lines and blue area in the figure). It is referred to the high speed fan gear ratio.

### *Volume percentiles*

As can be seen from Table 1, the three nozzles behave in a significantly similar manner. There is of course a slight variability, perfectly normal in items manufactured in large-scale, but the limited CV allows the averaged parameters to well represent the -albeit small- population.



**Figure 4** Visualization of the volume percentile diameters (means) with respect to airspeed. The plot was produced in MS Excel.

The means of the same values are visualized in Fig. 4, where it seems as though the air assistance pushes the droplet spectrum towards the coarser end. However, the effect of the gear ratio does not seem to influence the spectrum so much, hinting at a measurement artifact rather than a physical phenomenon. The main phenomenon that comes to mind is the disintegration of droplets by the shear force of the airflow, but this would affect the spectrum in the opposite way, by increasing the number of smaller droplets.

Since the airblast nozzle, by construction, is not affected by the airflow (it is not enclosed in the outlet duct), and therefore the droplet generation is about the same in all cases, new questions arise as to how the airflow influences the PDIA results: one explanation could be the higher impact that airspeed has on smaller droplets, accelerating them to the point of having a significantly smaller chance of being captured by the instrument. Numerical modelling of the transport phenomenon could help in addressing this question, as well as tweaking the settings of the instrument.



**Table 1** All the gathered data, ranging from the test bench to the different fan gear ratios.

	BENCH			NO AIR			LOW			HIGH		
NOZ.	D <sub>V10</sub>	D <sub>V50</sub>	D <sub>V90</sub>	D <sub>V10</sub>	D <sub>V50</sub>	D <sub>V90</sub>	D <sub>V10</sub>	D <sub>V50</sub>	D <sub>V90</sub>	D <sub>V10</sub>	D <sub>V50</sub>	D <sub>V90</sub>
I	134.1	386.7	704.1	144.5	333.4	691.3	256.4	501.4	775.6	271.4	517.4	812.2
II	132.1	344.0	642.4	133.8	327.0	702.0	236.3	474.9	789.7	259.6	499.1	790.0
III	152.9	380.5	662.4	139	363.9	779.7	258.4	503.7	776.1	271.3	516.8	788.5
MEAN	139.39	369.91	669.14	139.03	341.06	723.29	250.16	493.16	780.44	267.38	511.03	796.83
STD	9.37	18.84	25.70	4.37	16.10	39.39	9.98	13.07	6.53	5.54	8.49	10.84
CV	6.7%	5.1%	3.8%	3.1%	4.7%	5.4%	4.0%	2.6%	0.8%	2.1%	1.7%	1.4%

### *Analysis of velocities*

The average droplet velocities, summarised in Table 2, show a foreseeable trend: it comes to no surprise how increasing the speed of the accompanying airflow also increases the average velocity of the carried droplets. The faster droplets from the test bench with respect to the sprayer test without air assistance are also to be expected due to the action of gravity, as the nozzle in the test bench sprays directly downwards.

**Table 2** Results of the velocity analysis

NOZZLE	BENCH	NO AIR	LOW	HIGH
I	1.94	1.71	4.07	4.51
II	1.78	1.67	3.68	4.27
III	1.90	1.58	3.91	4.25
MEAN ± STD	1.87 ± 0.07	1.65 ± 0.05	3.88 ± 0.16	4.34 ± 0.12
CV	3.6%	3.3%	4.1%	2.7%

The velocity analysis could shed more light on the previously mentioned spectrum distortion phenomenon. In this direction, tweaking the instrument to gather faster droplets will be tried in the next test campaign, and a size-speed correlation will be investigated. Also reiterating this study at different downstream positions can confirm or dispute this hypothesis on droplet dynamics.

## CONCLUSIONS

The presented work lays the foundation for an automated instrument to evaluate the liquid distribution properties of orchard sprayers in working configurations by harnessing the potentialities enabled by optical instruments such as Particle/Droplet Image Analysis systems.

The idea is to move the instrument in front of the machine's outlet ducts, studying the relevant spatial distribution parameters of a combination of nozzles, rather than isolated ones, under the effect of air assistance.

Besides being easily reconfigurable to carry out the same task on field crop sprayers or even on sprayer Unmanned Aerial Systems (UAS) (Bloise et al., 2021), it could prove a powerful tool to validate nozzle performance models.

To answer the question as to why the droplet spectrum seems to become coarser with increasing airspeed, a numerical model accounting for the involved phenomena and the instrument's ability to capture droplets can be set up; to aid in this, measuring airspeed in a more punctual way becomes mandatory (the report from the WP5000 only provides a local average with a resolution of 10 cm), as does gathering more data, both from nozzles of the same type and different types.

Apart from the theoretical aspects of nozzle dynamics, the establishment of a measurement protocol to assess the distribution uniformity from a sprayer can only be worked out by correlating the data from the instrument, e.g. the drops/frame ratio, with deposition on trusted intercepting systems such as vertical patternators and water sensitive papers.

#### ACKNOWLEDGEMENTS

This study was carried out within the Agritech National Research Center and received funding from the European Union Next-Generation EU (PIANO NAZIONALE DI RIPRESA E RESILIENZA (PNRR) – MISSIONE 4 COMPONENTE 2, INVESTIMENTO 1.4 – D.D. 1032 17/06/2022, CN00000022). In particular, our study represents an original paper related to the Spoke 4 *Multifunctional and resilient agriculture and forestry systems for the mitigation of climate change risks* and in particular to the following Task: 4.2.3 titled *Big data analysis and decision support systems for the climate adaptation of agriculture and forestry*. This manuscript reflects only the authors' views and opinions, neither the European Union nor the European Commission can be considered responsible for them.

The raw data used for the study are available upon request to the corresponding author.

Finally, the authors would like to thank Caffini s.p.a. for the availability of the machine and the Südtiroler Beratungsring für Obst- und Weinbau/Centro di Consulenza per la Fruttivitecologia dell'Alto Adige for the availability of its testing facility.

#### REFERENCES

- Balsari, P., Grella, M., Marucco, P., Matta, F., & Miranda-Fuentes, A. (2019). Assessing the influence of air speed and liquid flow rate on the droplet size and homogeneity in pneumatic spraying: Air speed and liquid flow rate influence on droplets in pneumatic spraying. *Pest Management Science*, 75(2), 366–379. <https://doi.org/10.1002/ps.5120>
- Becce, L., Amin, S., Carabin, G., & Mazzetto, F. (2022). Preliminary spray nozzle characterization activities through shadowgraphy at the AgroForestry Innovation Lab (AFI-Lab). *2022 IEEE Workshop on Metrology for Agriculture and Forestry (MetroAgriFor)*, 136–140. <https://doi.org/10.1109/MetroAgriFor55389.2022.9965106>

- Bloise, N., Carreno Ruiz, M., D'Ambrosio, D., & Guglieri, G. (2021). Wind Tunnel Testing of Remotely Piloted Aircraft Systems for Precision Crop-Spraying Applications. *2021 IEEE International Workshop on Metrology for Agriculture and Forestry (MetroAgriFor)*, 378–383. <https://doi.org/10.1109/MetroAgriFor52389.2021.9628600>
- Castanet, G., Dunand, P., Caballina, O., & Lemoine, F. (2013). High-speed shadow imagery to characterize the size and velocity of the secondary droplets produced by drop impacts onto a heated surface. *Experiments in Fluids*, *54*(3), 1489. <https://doi.org/10.1007/s00348-013-1489-3>
- Kashdan, J. T., Shrimpton, J. S., & Whybrew, A. (2007). A digital image analysis technique for quantitative characterisation of high-speed sprays. *Optics and Lasers in Engineering*, *45*(1), 106–115. <https://doi.org/10.1016/j.optlaseng.2006.03.006>
- Lefebvre, A. H., & McDonnell, V. G. (2017). *Atomization and sprays* (Second edition). CRC Press, Taylor & Francis Group, CRC Press is an imprint of the Taylor & Francis Group, an informa business.
- Minov, S., Cointault, F., Vangeyte, J., Pieters, J., & Nuyttens, D. (2016). Spray Droplet Characterization from a Single Nozzle by High Speed Image Analysis Using an In-Focus Droplet Criterion. *Sensors*, *16*(2), 218. <https://doi.org/10.3390/s16020218>
- Pascuzzi, S., Manetto, G., Santoro, F., & Cerruto, E. (2021). A Brief Review of Nozzle Spray Drop Size Measurement Techniques. *2021 IEEE International Workshop on Metrology for Agriculture and Forestry (MetroAgriFor)*, 351–355. <https://doi.org/10.1109/MetroAgriFor52389.2021.9628757>
- Pascuzzi, S., & Mazzetto, F. (2021). Feasibility study of using laser technology for calibrating orchard sprayer machinery. First results. *2021 IEEE International Workshop on Metrology for Agriculture and Forestry (MetroAgriFor)*, 367–371. <https://doi.org/10.1109/MetroAgriFor52389.2021.9628610>
- Tappeiner, U., Marsoner, T., & Niedrist, G. (2020). *Rapporto sulla sostenibilità dell'agricoltura – Alto Adige*. Eurac Research.

---

---



## ANALYSIS AND COMPARISON OF THE NOISE OF HAND-HELD AND BACK-PACK TYPE GRASS TRIMMERS

Jurica Plukavec<sup>1</sup>, Dubravko Filipović<sup>2\*</sup>, Igor Đukić<sup>3</sup>, Krešimir Čopec<sup>2</sup>, Igor Kovačev<sup>2</sup>

\*E-mail of corresponding author: dfilipovic@agr.hr

<sup>1</sup>SPIDO PLO d.o.o., Trg Francuske republike 5, 10000 Zagreb, Croatia

<sup>2</sup>University of Zagreb Faculty of Agriculture, Svetosimunska 25, 10000 Zagreb, Croatia

<sup>3</sup>University of Zagreb Faculty of Forestry and Wood Technology, Svetosimunska 25,  
10000 Zagreb, Croatia

### ABSTRACT

*Grass trimmers are identified as a type of machines whose operators are exposed to high noise levels. The high noise level combined with the long exposure time of the operator can cause temporary or permanent noise-induced hearing loss (NIHL). The objective of this study was to evaluate and compare noise levels emitted by the two types of grass trimmers from same manufacturer: hand-held and back-pack type, with approximately the same engine power (1.7 vs. 1.6 kW). Noise levels at operator's ears were measured at engine idling mode and full load mode. A significantly higher noise levels were measured when grass trimmers worked in the full load mode. All measured parameters of the noise level were significantly higher ( $P < 0.05$ ) at the hand-held grass trimmer. The daily personal noise exposure  $LEX,8h$  for operators of both grass trimmers were above the exposure limit value specified in the European Directive 2003/10/EC, 99.0 dB(A) at hand-held type and 90.5 dB (A) at back-pack type of grass trimmer. The frequency analysis of sound pressure level in the full load mode showed that the highest sound pressure levels were recorded in the frequency range 630-4000 Hz with the peak at 800 Hz at both grass trimmers.*

**Keywords:** ergonomics, noise, grass trimmer, exposure limit value, exposure action value

### INTRODUCTION

The grass trimmers are hand-carried machines that are widely used to maintenance of public areas such as parks and areas along public roads, as well as private yards and house gardens. The use of these machines in agriculture is the best way for cutting long grass in

narrow areas such as rows in orchards and vineyards due to different levels and difficult angles that the grass can grow and where the use of a lawn mower is not practical (Jaafar et al., 2017). The use of grass trimmers for mechanical weed control is also more environmentally friendly than the use of herbicides (Hao and Ripin, 2013; Bernardi et al., 2018). The main parts of grass trimmer are petrol engine, drive shaft and cutting head with a nylon line. Two-stroke single-cylinder petrol engines with small displacement volume are used to drive because of its small weight and size, and the possibility to operate the device in different positions (Figlus et al., 2013). With regard to the location of the engine, two basic versions of the grass trimmers are hand-held and back-pack type. Hand-held type has the engine at the front connected to the cutting head by a rigid shaft, while at the backpack type the engine is located on the support on the operator's back and is connected to the cutting head by a flexible cable coupled to another rigid shaft. The operators of grass trimmers are exposed to large levels of noise and most of these workers are of lower education with less awareness of occupational safety and health, such as noise-induced hearing loss (NIHL) (Mallick et al., 2009). At the time of intense vegetation growth, the communal and agricultural workers use them daily, sometimes 8 hours a day, and in other periods not used them or used significantly less (Tint, 2012). High noise levels in conjunction with long work hours could cause temporary or permanent reduction in their hearing. This means that many operators could lose their hearing due to exposure of high noise levels at work, along with all the professional and social consequences (Karamousantas et al., 2009). The primary source of grass trimmer noise is the engine, while the secondary noise comes from the nylon line that breaks out the plants. According to Mallick et al. (2009), the primary source of noise is of interest for the analyst whereas contribution of secondary source is negligible.

Operators' exposure to noise in the workplace is regulated by the European Directive 2003/10/EC (Council of the European Union, 2003), which specifies the minimum requirements for the protection of workers from risks to their health and safety arising or which may arise due to exposure to noise, especially the risk to hearing. This Directive defines the exposure limit value and exposure action values in respect to the daily and weekly noise exposure level as well as peak sound pressure. According to this Directive, the exposure limit value is limited to 87 dB(A) and no worker should be exposed to a higher level of noise, taking into account hearing protection. The lower exposure action value is limited to 80 dB(A) and in case of exceeding it, the employer must provide information and training for workers and provide them hearing protection. The upper exposure action value is limited to 85 dB(A) and in case of exceeding it, the employer must take reasonably practicable measures to reduce worker's noise exposure. In addition to determination of the daily noise exposure level, assessment of noise exposure at workplaces in accordance with the European Directive 2003/10/EC may require measurement of the C-weighted peak sound pressure level which corresponds to the absolute peak value of a sound pulse, and is used as a quantity describing the mechanical exposure of human hearing to a discrete noise event (Maue, 2009). The most common measure to assess exposure to noise at the workplace is the daily noise exposure level obtained from the measured noise level and the measurement time calculated for a nominal 8 hour working day. The objective of this study was to evaluate and compare the noise level of two basic types of grass trimmers, hand-held and back-pack type.

## MATERIALS AND METHODS

The noise level measurements were carried out during October 2022 in the Testing station of Agricultural Engineering Department, University of Zagreb Faculty of Agriculture (45° 51' N, 16° 04' E). In order to evaluate the noise level, two grass trimmers of the same manufacturer, hand-held and back-pack type, were selected for this study. The both trimmers are used, the back-pack grass trimmer is older, but has been used less annually, so it can be assumed that the tested grass trimmers have approximately the same number of working hours. The technical characteristics of the tested grass trimmers are shown in Table 1. The noise levels were measured in two working modes: at engine idling and full load. Measurements were conducted during sunny and windless weather, and both grass trimmers were operated by the same operator during all measurements.

**Table 1** Technical characteristics of the tested grass trimmers

Grass trimmer type	Hand-held	Back-pack
Grass trimmer version	FS 240	FR 350
Grass trimmer manufacturer	Stihl	Stihl
Engine type	two-stroke gasoline	two-stroke gasoline
Number of cylinders	1	1
Displacement (cm <sup>3</sup> )	37.7	40.2
Engine power (kW)	1.7	1.6
Engine idling speed (rpm)	2800	2800
Max. output speed (rpm)	9360	8790
Grass trimmer weight (kg)	6.9	10.4
Total length (cm)	180	280

Noise level of grass trimmers was measured with a sound level meter and analyzer B&K 2250-L (Brüel & Kjær, Nærum, Denmark) in accordance with international standard ISO 9612:2009 (ISO, 2009). According to the electroacoustic performance specifications given in IEC standard 61672-1 (IEC, 2013), this sound level meter is a Class 1 sound measuring instrument. During the measurements, the microphone of the sound level meter was positioned as close as possible to the operator's ear. For each grass trimmer and working condition, noise level was measured at both ears of the operator, and the duration of each measurement was one minute. For each working condition, five independent measurements were carried out. Before each measurement cycle was performed calibration using a sound calibrator B&K 4231 (Brüel & Kjær, Nærum, Denmark) which provides a stable sound pressure at 1 kHz and has minimal susceptibility to environmental factors. The measurements were made in an open space without obstacles and the background noise was between 43 and 46 dB(A), so it had no influence on the noise level during the measurements. For almost all measured parameters, A-frequency weighting was applied, except for measurement of peak

levels where C-frequency weighting is applied. The A-weighting is the most commonly applied frequency weighting because it adjusts the sound pressure level readings to reflect the sensitivity of the human ear at medium-range levels. For measuring peak sound levels, C-frequency weighting is the most commonly applied because it better shows the effect of low frequency sounds on the human ear than the A-weighting, and also takes into account the energy present at low frequencies. Time weighting specifies how the sound level meter reacts to changes in sound pressure and was set to fast time weighting during all measurements. During the measurement of the noise level of two grass trimmers, the following parameters were recorded:

- $L_{Aeq}$  (dB) is the equivalent continuous A-weighted sound pressure level of one minute interval which over the duration of the measuring period would contain the same amount of energy as the actual noise during this period.
- $L_{Cpeak}$  (dB) is the peak C-weighted sound pressure level of one minute interval defined as the maximum sound pressure level occurring during the measuring period.
- $L_{AF90}$  (dB) is the noise level exceeded for 90% of the measurement period with 'A' frequency weighting calculated by statistical analysis from samples of the Fast time weighted sound level.
- $L_{AFmax}$  (dB) is the maximum noise level with A-weighting and fast time weighting during the measurement period.
- $L_{AFmin}$  (dB) is the minimum noise level with A-weighting and fast time weighting during the measurement period.

The daily noise exposure value  $L_{EX,8h}$  is used to quantify operator's noise exposure at the workplace during an 8 h working day. If operators are exposed to different noise levels and durations during the working day, according to international standard ISO 1999:2013 (ISO, 2013), the daily noise exposure value  $L_{EX,8h}$  can be calculated using the following formula:

$$L_{EX,8h} = 10 \cdot \log \left( \sum_{i=1}^N \frac{T_i}{T_0} 10^{0.1 \cdot L_{Aeq,i}} \right) \quad (1)$$

where: N is the number of different working modes,  $T_i$  is the duration of the  $i^{th}$  working mode in minutes,  $T_0$  is the reference value of 480 min (one standard working day of eight hours) and  $L_{Aeq,i}$  is the equivalent continuous A-weighted sound pressure level of the  $i^{th}$  working condition in dB(A).

Additionally, the one-third octave band analysis was done within the range from 12.5 Hz to 16 kHz in order to observe the differences in the noise level at certain frequencies within that spectrum. The processing of the measured data was done using B&K Environmental software Version 5.4 (Brüel & Kjær, Nærum, Denmark). Statistical analysis of the measured data was performed using the Excel program.

## RESULTS AND DISCUSSION

When operators working with a grass trimmer, the two most common operating modes they use are idling and full load. Idling mode is used mainly when the operator walking or orientating himself before starting work on a new surface (Huber et al., 2021). Comparison of



the measured noise level parameters emitted by the two types of grass trimmers in idling mode is shown in Table 2. The analysis of measured noise level parameters showed a significant difference ( $P < 0.05$ ) between the noise level at the left and right ear of the hand-held grass trimmer operator in all parameters. The reason for this is that the operator is right-handed, and the drive engine, which is the primary source of the grass trimmer's noise, was positioned on the operator's right side during measurements. Considering that the back-pack grass trimmer is positioned in the middle of the operator's back, there were no significant differences of the noise level at the operator's left and right ear, but slightly lower noise level was measured at the right ear. The reason for this is the shielding of the side of the back-pack grass trimmer where the drive transmission is connected to the flexible cable, and if the operator is right-handed, slightly lower noise level is emitted on that side. If the measured noise level parameters of two types of grass trimmers are compared, a significantly higher noise level in idling mode was emitted by hand-held grass trimmer, but the values of all measured parameters of both grass trimmers were below the exposure action values specified in the European Directive 2003/10/EC.

**Table 2** Comparison of the measured noise level parameters emitted by the two types of grass trimmers in idling mode

Parameter	Hand-held grass trimmer		Back-pack grass trimmer	
	Left ear	Right ear	Left ear	Right ear
$L_{Aeq}$ (dB)	70.5 <sup>a</sup>	75.1 <sup>b</sup>	69.8 <sup>a</sup>	69.4 <sup>a</sup>
$L_{Cpeak}$ (dB)	93.0 <sup>a</sup>	98.3 <sup>b</sup>	91.6 <sup>a</sup>	91.2 <sup>a</sup>
$L_{AF90}$ (dB)	69.8 <sup>a</sup>	74.3 <sup>b</sup>	69.3 <sup>a</sup>	69.1 <sup>a</sup>
$L_{AFmax}$ (dB)	71.7 <sup>a</sup>	76.5 <sup>b</sup>	70.7 <sup>a</sup>	70.2 <sup>a</sup>
$L_{AFmin}$ (dB)	68.6 <sup>a</sup>	72.7 <sup>b</sup>	68.8 <sup>a</sup>	68.8 <sup>a</sup>

Values in the same rows marked with different letters differ significantly ( $P < 0.05$ )

Since the grass trimmers don't have the ability to fine-tune of the working speed, the operators usually depress the throttle trigger all the way down and work in the full load mode. Comparison of the measured noise level parameters emitted by the two types of grass trimmers in the full load mode is shown in Table 3. As expected, compared to idling mode, a significantly higher noise levels were measured when grass trimmers worked in the full load mode. Thereby, all measured parameters with A-weighting were above the exposure limit value of 87 dB(A) specified in the European Directive 2003/10/EC. It can also be seen from Table 3 that all measured parameters of the noise level were significantly higher ( $P < 0.05$ ) at the hand-held grass trimmer. The differences in the measured noise level between left and right ear can be seen at both grass trimmers, but due to the higher values in comparison to idling mode, these differences were not significant. Calvo et al. (2019) also found little difference in noise level of back-pack powered machines between the left and the right ear, and concluded that the noise level measured at the right ear was slightly higher because the operators were right-handed.

The equivalent continuous A-weighted sound pressure level  $L_{Aeq}$  emitted by the back-pack grass trimmer was much lower than  $L_{Aeq}$  values reported by Malick et al. (2009) for two different back-pack grass trimmers with 100.1 and 105.1 dB(A). In this study sound pressure level  $L_{Aeq}$  emitted by the hand-held grass trimmer was significantly higher ( $P < 0.05$ ) than those emitted by the back-pack grass trimmer, but Naskrent et al. (2020) reported much lower  $L_{Aeq}$  values for the hand-held grass trimmer in the range 91.5-94.7 dB(A). Haron et al. (2015) reported mean values of the maximum noise level emitted by back-pack grass trimmers in the range 97.7-103.6 dB(A), which is much higher of the mean value of the maximum noise level measured in this study of the back-pack grass trimmer, but similar to that of the hand-held grass trimmer. A much higher mean value of the maximum noise level with A-weighting emitted by the back-pack grass trimmer of 109.5 dB(A) was reported by Tengku Hanidza et al. (2013). The peak C-weighted sound pressure levels  $L_{Cpeak}$  measured in this study were far below the peak action values of 135 dB and 137 dB specified in the European Directive 2003/10/EC. Considerably higher  $L_{Cpeak}$  values of the hand-held grass trimmer compared to the values measured in this study was reported by Naskrent et al. (2020) with 122.1 dB. However, Maue (2009) consider that the peak action values of 135 dB and 137 dB specified in the European Directive 2003/10/EC are reached at very few industrial workplaces.

**Table 3** Comparison of the measured noise level parameters emitted by the two types of grass trimmers in full load mode

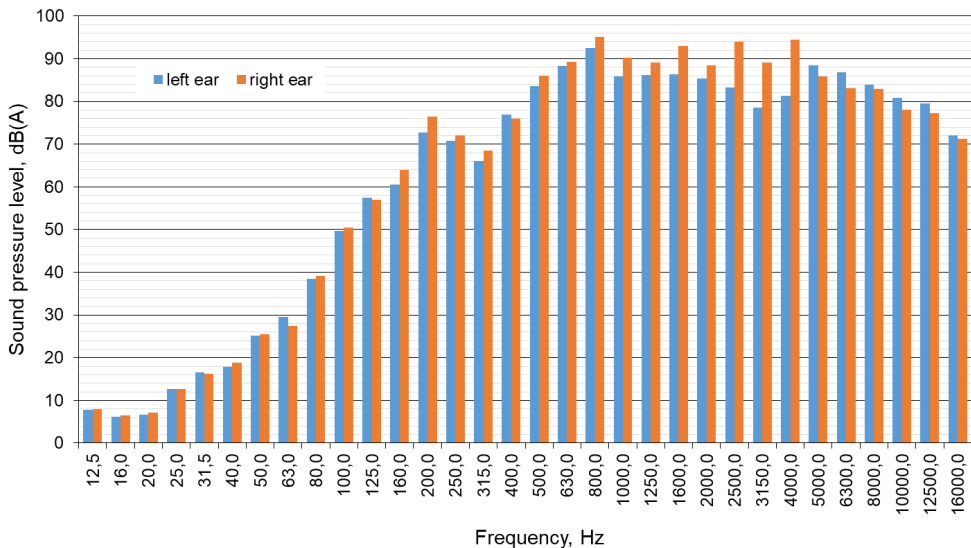
Parameter	Hand-held grass trimmer		Back-pack grass trimmer	
	Left ear	Right ear	Left ear	Right ear
$L_{Aeq}$ (dB)	98.0 <sup>a</sup>	102.0 <sup>a</sup>	93.5 <sup>b</sup>	89.8 <sup>b</sup>
$L_{Cpeak}$ (dB)	112.0 <sup>a</sup>	115.4 <sup>a</sup>	108.2 <sup>b</sup>	104.5 <sup>b</sup>
$L_{AF90}$ (dB)	97.5 <sup>a</sup>	101.1 <sup>a</sup>	93.2 <sup>b</sup>	89.5 <sup>b</sup>
$L_{AFmax}$ (dB)	98.9 <sup>a</sup>	103.6 <sup>a</sup>	94.3 <sup>b</sup>	90.5 <sup>b</sup>
$L_{AFmin}$ (dB)	97.3 <sup>a</sup>	100.2 <sup>a</sup>	92.8 <sup>b</sup>	89.2 <sup>b</sup>

Values in the same rows marked with different letters differ significantly ( $P < 0.05$ )

The exposure time is, aside from the equivalent continuous sound pressure level, the decisive quantity to assess the health risks of noise exposure (Huber, 2021). In order to calculate the daily noise exposure value  $L_{EX,8h}$ , it was necessary to determine the average total time that operators work with the grass trimmer per day in a particular working mode. By monitoring the work of grass trimmer operators employed in the company SPIDO PLO d.o.o., it was concluded that during the season they work with grass trimmers for an average of 4.5 hours per day, of which 4 hours in full load mode and 0.5 hour in idling mode. Based on this, it was calculated that the daily noise exposure value for the hand-held grass trimmer operators is 99.0 dB(A), and for the back-pack grass trimmer operators 90.5 dB(A). So, in this study measured  $L_{EX,8h}$  values at both grass trimmers were above the exposure limit value specified in the European Directive 2003/10/EC, whereby the operator in work with hand-held grass trimmer was exposed to significantly higher noise level. The values of the daily noise exposure level above the exposure limit value were also reported by Calvo et al. (2016) and

Naskrent et al. (2020) for the hand-held grass trimmers, as well as Haron et al. (2015) and Tengku Hanidza et al. (2013) for the back-pack grass trimmers.

Since the duration of exposure plays an important role in the causative of noise induced hearing loss (NIHL), it is important to measure it in the grass-trimming workers. The level of noise is not constant and may be different among various models and age of the machines (Jaafar et al., 2017). Naskrent et al. (2020) consider that there are many factors that significantly influence the noise level when using the grass trimmer. The difference in the produced sound pressure level can be attributed to the design features of the grass trimmer engines (Malick et al., 2009). According to Sorica et al. (2017), the engine revolutions per minute have a significant influence on the sound pressure level of the grass trimmer, which increase as the engine rpm increases. According to Figlus et al. (2013), the engine power and capacity, as well as its technical condition, directly impact the noise level to which the operator is exposed. They stated that in the case of engines with comparable displacements, the higher the engine power, the higher the noise is. It results the fact that an engine with the same displacement but with higher power is more strained in comparison to an engine with smaller power. If the daily noise exposure level is exceeded, the operators need to be trained and informed about the noise exposure risks and use hearing protection devices (Calvo et al., 2016). These devices are easily implemented, low-cost methods of minimizing hearing loss from continuous exposure to high-intensity noise (Mohammadi, 2008).

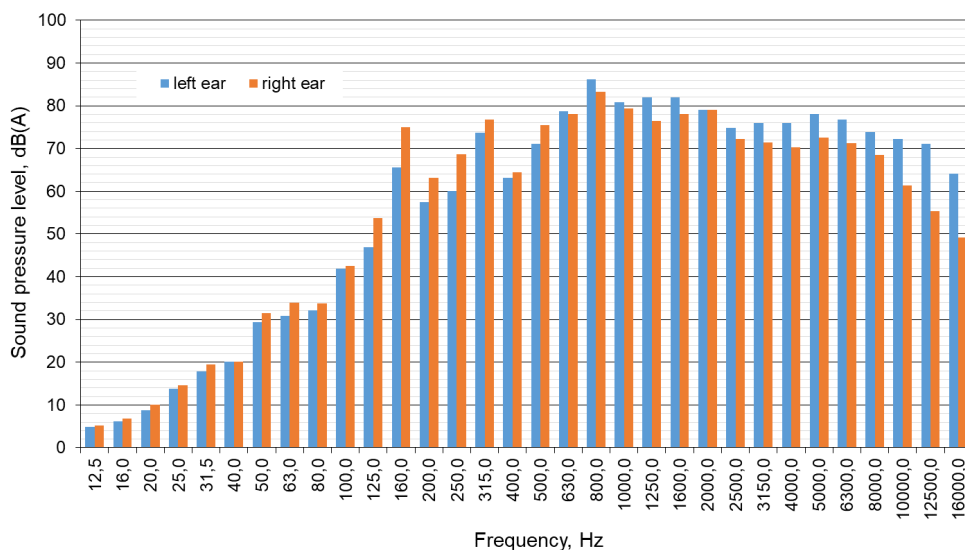


**Figure 1** Frequency analysis of sound pressure level of a hand-held grass trimmer in full load mode

The noise frequency analysis is necessary in selection of adequate personal protective equipment as it is one of the most accurate methods to predict its attenuation (Salvendy, 2012). According to Reinhold et al. (2014), the effectiveness of a personal protective equipment at different frequencies varies. Considering that the values of all measured parameters of both

grass trimmers in idling mode were below the exposure action values specified in the European Directive 2003/10/EC, the frequency analysis will only be presented for the full load mode. The frequency analysis of sound pressure level of a hand-held grass trimmer in full load mode is presented in Figure 1. The one-third octave band analysis within the range from 12.5 Hz to 16 kHz showed that the highest sound pressure levels were between 630 Hz and 4000 Hz with the peak at 800 Hz, while at higher frequencies it decreases. At frequencies below 100 Hz the sound pressure level was very low. The largest differences in sound pressure level between the left and right ear are observed in the range 800–4000 Hz, and in that range significantly higher values were recorded at the right ear. At high frequencies above 4000 Hz, higher values were recorded at the left ear, but the differences were considerably lower.

The frequency analysis of sound pressure level of a back-pack grass trimmer in full load mode is presented in Figure 2. The highest sound pressure levels were also between 630 Hz and 4000 Hz with the peak at 800 Hz, but with significantly lower values in comparison to sound pressure level of hand-held grass trimmer. At all frequencies above 500 Hz, higher values of sound pressure level were recorded at the left ear with a significant difference at frequencies above 10 kHz. In contrast, at all frequencies below 500 Hz higher values of sound pressure level were recorded at the right ear. Mallick et al. (2009) also conducted a noise frequency analysis of two back-pack grass trimmers and observed that the main peaks of noise were at 630 and 800 Hz, respectively.



**Figure 2** Frequency analysis of sound pressure level of a back-pack grass trimmer in full load mode

The results of noise measurements at various frequencies are used to identify the specific frequencies with especially high intensity (Franklin et al., 2006). The measurement of the noise frequency is important to associate it with the frequency of hearing loss (Jaafar et al., 2017). Moreover, it gives an indication about the noise levels in most hearing-damaging

frequencies which are the main concern in selecting the workers' hearing apparatus and serve as basis in estimating numerically the risk of noise-induced hearing impairment if no risk control measures are applied or the worker misuses them. Knowing the prevailing damaging frequencies helps to decide which ear protection should be used (Tint et al., 2012).

## CONCLUSIONS

The results obtained in this study indicate that the operators of grass trimmers are exposed to a high noise levels. All measured parameters of the noise level were significantly higher ( $P < 0.05$ ) at the hand-held grass trimmer. The daily personal noise exposure  $L_{EX,8h}$  for operators of both grass trimmers were above the exposure limit value specified in the European Directive 2003/10/EC, 99.0 dB(A) at hand-held type and 90.5 dB (A) at back-pack type of grass trimmer. The highest sound pressure levels were recorded in the frequency range 630-4000 Hz with the peak at 800 Hz at both grass trimmers. The high noise level combined with the long exposure time of the operator can cause temporary or permanent noise-induced hearing loss. Continuous education of the grass trimmer operators about the risks and protect from hearing loss is required with the mandatory use of appropriate personal protective equipment.

## REFERENCES

- Bernardi, B., Quendler, E., Benalia, S., Mantella, A., Zimbalatti, G. (2018). Occupational risks related to vibrations using a brush cutter for green area management. *Ann Agric Environ Med* 25, 255–258.
- Calvo, A., Deboli, R., Preti, C. (2016). Operators' exposure to noise and vibration in the grass cut tasks: Comparison between private and public yards. *Agric Eng Int CIGR J* 18, 213-225.
- Calvo, A., Preti, C., Caria, M., Deboli, R. (2019). Vibration and noise transmitted by agricultural backpack powered machines critically examined using the current standards. *Int J Environ Res Public Health* 16, 2210.
- Council of the European Union. (2003). Directive 2003/10/EC on the minimal health and safety requirements regarding the exposure of workers to the risks arising from physical agents (noise). Council of the European Union, Brussels.
- Figlus, T., Wilk, A., Franke, P. (2013). The estimation of changes in the noise level generated by devices equipped with two-stroke internal combustion engines with small displacement volume. *FME Trans* 41, 216-221.
- Franklin, R.C., Depczynski, J., Challinor, K., Williams, W., Fragar, L.J. (2006). Factors affecting farm noise during common agricultural activities. *J Agric Saf Health* 12, 117–125.
- Hao, K.Y., Ripin, Z.M. (2013). Nodal control of grass trimmer handle vibration. *Int J Ind Ergon* 43, 18-30.
- Haron, Z., Darus, N., Han, L.M., Jahya, Z., Hamid, M.F.A., Yahya, K., Lee, Y.L., Shek, P.N. (2015). A preliminary study of occupational noise exposure among leaf blower and grass cutter workers in public university. *J Teknol* 77, 153–159.
- Huber, M., Hoffmann, S., Brieger, F., Hartsch, F., Jaeger, D., Sauter, U.H. (2021). Vibration and noise exposure during pre-commercial thinning operations: What are the ergonomic benefits of the latest generation professional-grade battery-powered chainsaws?. *Forests* 12, 1120.
- IEC. (2013). IEC standard 61672-1 Electroacoustics - Sound level meters - Part 1: Specifications, International Electrotechnical Commission (IEC), Geneva.

- ISO. (2009). ISO standard 9612:2009 Acoustics - Determination of occupational noise exposure - Engineering method. International Organization for Standardization (ISO), Geneva.
- ISO. (2013). ISO standard 1999:2013 Acoustics - Estimation of noise-induced hearing loss. International Organization for Standardization (ISO), Geneva.
- Jaafar, N.I., Md Daud, M.K., Mohammad, I., Abd Rahman, N. (2017). Noise-induced hearing loss in grass-trimming workers. *Egypt J Ear Nose Throat Allied Sci* 18, 227–229.
- Karamousantas, D., Varzakas, T., Kanakis, A. (2009). Noise levels produced by agricultural machinery and different farming processes. *Int J Acoust Vib* 14, 220-225.
- Mallick, Z., Badruddin, I.A., Khaled Hussain, M.T., Salman Ahmed, N.J., Kanesan, J. (2009). Noise characteristics of grass-trimming machine engines and their effect on operators. *Noise Health* 11, 98–102.
- Maue, J.H. (2009). The relevance of the peak sound pressure level to the assessment of industrial workplaces. In: Boone M.M. (ed) *Proceedings of the International Conference on Acoustics (NAG/DAGA 2009)*, Rotterdam, Netherlands, 805-807.
- Mohammadi, G. (2008). Hearing conservation programs in selected metal fabrication industries. *Appl Acoust* 69, 287–292.
- Naskrent, B., Grzywinski, W., Lukowski, A., Polowy, K. (2020). Influence of cutting attachment on noise level emitted by brush cutter during tending of young forests. *Croat J For Eng* 41, 129-135.
- Reinhold, K., Kalle, S., Paju, J. (2014). Exposure to high or low frequency noise at workplaces: Differences between assessment, health complaints and implementation of adequate personal protective equipment. *Agron Res* 12, 895–906.
- Salvendy, G. (2012). *Handbook of human factors and ergonomics*. John Wiley & Sons, New Jersey.
- Sorica, E., Vladut, V., Cardei, P., Sorica, C., Bracacescu, C. (2017). Comparative analysis of the noise and vibration transmitted to the operator by a brush cutter. In: Herisanu N., Vasilae M. (eds) *Proc 14th AVMS Conf*, Timisoara, Romania, 165-172.
- Tint, P., Tarmas, G., Koppel, T., Reinhold, K., Kalle, S. (2012). Vibration and noise caused by lawn maintenance machines in association with risk to health. *Agron Res* 10, 251-260.
- Tengku Hanidza, T.I., Amirah, A.M.J., Ramdzani, A., Madinah, A. (2013). A preliminary study of noise exposure among grass cutting workers in Malaysia. *Procedia Soc Behav Sci* 91, 661-672.



## ESTIMATION OF THE PARAMETERS OF THE PORTLAND CEMENT CLINKER GRINDING EQUATION IN THE BALL MILL

George IPATE<sup>1\*</sup>, Cristian CIOBANU<sup>1</sup>, Gheorghe VOICU<sup>1</sup>, Filip ILIE<sup>1</sup>,  
Madalina STEFAN<sup>1</sup>, Paula TUDOR<sup>2</sup>, Iuliana GAGEANU<sup>3</sup>, Petru CARDEI<sup>3</sup>,  
Dan CUJBESCU<sup>3</sup>

\*E-mail of corresponding author: [puiu.ipate@gmail.com](mailto:puiu.ipate@gmail.com)

<sup>1</sup>Department of Biotechnical Systems, University "POLITEHNICA" of Bucharest, Romania

<sup>2</sup>Department of Management, University "POLITEHNICA" of Bucharest, Romania

<sup>3</sup>National Institute for Research-Development of Machines and Installations Designed for Agriculture and Food Industry - INMA Bucharest, Romania

### ABSTRACT

*This study presents a method for determining the fractionation rate of clinker in the grinding process with ball mills, a parameter that defines the fracturing of the material and the particle size distribution function. In the paper, the kinetic model of the clinker granule crushing process was taken into account. In the grinding process, reducing the size leads to a growth of the particle surface, though at the similar period a partial growth in the dimension of the particles due to aggregation and cluster is also observed. In both cases, energy is lost. For this purpose, substantial survey is conducted to determine fracture rate values that underline the change in particle size distributions in order to find a method to stop this energy loss. Estimation of the differential equation parameters for grinding was carried out with specialized programs provided by the Matlab package, and the validation was performed for a set of experimental data.*

**Keywords:** *clinker, ball mill, fractionation rate, MATLAB.*

### INTRODUCTION

Cement manufacturing industry, a fine, gray powder, obtained by grinding clinker, gypsum, as well as some additional materials (slag, limestone, etc.) has a major role both in the development and modernization of human society, as well as in the impact on the environment. Worldwide, the industry produced, in the middle of the last decade, around 4.7 billion tons of cement, which means around 520 kg of cement/capita, sufficient amount to produce around 1.6 m<sup>3</sup> of concrete for every inhabitant of the planet. At the same time, the

specific gross average level of CO<sub>2</sub> emissions is of the order of 870 kg CO<sub>2</sub> per ton of cement clinker (Schumacher and Juniper, 2013).

Grinding raw materials in ball mills is an energy-consuming process. Studies show that about 83% of the aggregate power consumed in the manufacture of cement are employed for reducing the dimension of the coarser matter and for grinding, about 75% of the aggregate power being absorbed only in the milling activity. The level of productivity of a ball mill is quite controversial, depending on the point of view and how it is defined. A larger amount of fine clinker can often lead to a more difficult grinding process, and thus the objective of obtaining less than 25% of clinker with a size below 1 mm is also appropriate when choosing ball mills.

The advantages of choosing ball mills (fig. 1) for the clinker grinding process are: (i) they can operate in a wet or dry environment; (ii) lower installation and maintenance costs; (iii) materials can have different degrees of hardness; (iv) can be used for batch or continuous operation; (v) a broad variety of particle dimension can be obtained.

Particle dimension decrease relies upon on the subsequent fundamental element:

- the specifics of the matter loaded in the plant;
- special character of the milling medium (mass, density);
- rotation speed of the drum grinder;
- sludge concentration in case of wet milling working.



**Figure 1** Ball mil for clinker cement grinding

The theoretical foundations of the milling grinding of clinker in ball mills and its role in cement manufacturing have already been investigated in numerous research papers (Reid, 1965; Deniz, 2012; Qian et al., 2013, Little et al., 2017), but the first analyzes of kinetic parameters specific to real mill power were recently performed (Gupta and Sharma, 2013). The latter propose a mathematical model that is based on the explicit fracture rate of the powder and on the fracture distribution variable for different particle sizes. It is demonstrated that the almost entire specification of the milling procedure in a ball grinder is given by the milling array having into judge the conversion of the granules composition inside the grinder cylinder respectively, why the corresponding weight fraction of the cracked material powder reaches to the appropriate fraction desired.

Gupta and Kapur (1974) stated that the frequency function of grind nodules is the very comprehensive, precise expression constants derived from the traditional milling kinetic



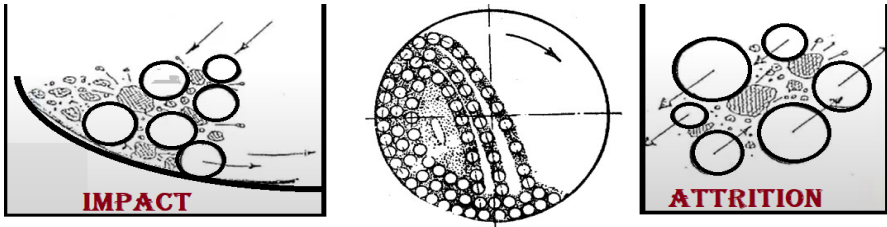
model. The relation describes the full track alone for an introductory period, of the particle size range over time. Sharapov (2018) proposes a new approach that allows the determination of grinding kinetics parameters, rely upon on the design parameters of the grinding plant used, investigated on a commercial cement ball mill and corroborated on a pilot equipment.

Bwalya et al. (2014) studied the impact of ball dimensionality distribution on the milling rate of coal in an abrasion plant. They used standard methodology for determining the range and rupture function variable for batch operation, showing why ball size distribution undermining mill performing. They demonstrated that plant capability is linearly related to the surface region of the grinding medium, and that feeding a modest segment of hard-to-grind material wish to have a strong influence on general execution.

One of the objectives of our research was intended in relation to achieving a more complete comprehension and a more precise mathematical explanation of the milling process in an effort to reduce the amount of natural raw materials used in the production processes, and by this measure, to protect the environment. Also, by using alternative raw materials based on waste or by-products from other industries in the production of clinker (Ciobanu et al., 2022; Da et al., 2021, Prabhakaran and Swaminathan, 2022), as well as in the grinding of cement, but strictly ensuring that the final product fully complies with the requirements imposed by the European product standard SR EN 197-1:2011, will significantly increase performance in terms of reducing environmental impact.

## MATERIAL AND METHODS

The granules (grinding media) inside the grinding chamber are agitated by the spinning of the grind cylinder and the particles are grinded by collision with the steel balls, as well as due to the shearing forces in contact with them (fig. 2) (Oseni et al., 2011).



**Figure 2** Material fracture mechanisms in the ball mill

The fundamental equation of material comminution can be written as (Gupta and Sharma, 2013):

$$\frac{\partial^2 R(x,t)}{\partial x \partial t} = -k(x) \cdot \frac{\partial R(\varphi,t)}{\partial x} + \int_x^{x_0} \frac{\partial F(x,\varphi)}{\partial x} \cdot k(\alpha) \cdot \frac{\partial R(\varphi,t)}{\partial x} \cdot d\varphi \quad (1)$$

For this equality,  $R(x, t)$  represents the mass percentage of matter smaller than dimension  $x$  after milling a certain type of matter in dimension distribution  $R(x, t=0)$  and highest

dimension  $x_0$ , for a period  $t$  and  $F(x, \varphi)$  is the fracture function, provision the percentage of matter lesser than dimension  $x$  derived by main fracture of matter of dimension  $\varphi$ . Main fracture of the material relates to the conditions below that the products of neither fracture occurrence no longer undergo any split. The expression  $k(x)$ , is the fracture rate for the matter of dimension  $x$  and is presented in the specialized literature either as a selection function. This method is run to the supposition that the rupture velocity is independent of time, which defines an implicit primary order response since if  $M(x, t) = \partial R(x, t) / \partial x$ .  $dx$  refers to the mass percentage of the matter in the dimension range from  $x$  to  $x + dx$ .

The fracture rate by breaking the material is given by the relation:

$$-\frac{dM(x,t)}{M(x,t)} = k(x) \quad (2)$$

which through integration leads to an analytical solution of the form:

$$M(x, t) = M(x, 0) \cdot \exp [-k(x)t] \quad (3)$$

The relation (1) derives from the law of conservation mass on the mass percentage of the substance  $M(x, t)$  in the difference dimension range upon  $x$  to the  $x + dx$ . The relation shows how the net rate of making of the material production of any size  $x$  is equal to the rate of making of that dimension from the rupture of all substance of the initial dimension greater than dimension  $x$  subtraction the rate of rupture of the substance of dimension  $x$ .

The integro-differential relation (1) does not have a straightforward, precise resolve merely according to specific conditions, it can deteriorate into a relation with a familiar resolve. If we examine the major dimension of any substance or initiate grinding with a substance of one dimension, then the fracture of particles with the major dimension is specified in relation (2). When the unavailability of a precise resolve to relation (1), a restricted differentiate numerical approach method can be employed to solve it in that one or simultaneously variable, particle dimension and duration are discretized in little increase. The precision of the finite difference approximation solving relies upon on the dimension of the increase employed. The utilization of restricted differentiate necessitates a meticulous rethinking of the facilitated task in terms of the increase chosen and the consequent answer must be reviewed as a function of the dimension of the increase since the precise resolve outcome just in the restricted case of the difference increase (Reid, 1964).

Instead of the exclusively abstract form of relation (1), an equation based on practical parameters that can be determined directly by experiment is used. To describe by equation (1) continuously operating grinding systems, an approximation solution is sought by the finite difference method that uses dimensional magnitude intervals and retain an uninterrupted duration scale. Since particle dimension distributions are normally resolved by the screening procedure according to a regular sieve fraction a time-continuous solving of equation (1) has certain advantages when the time scale is extended:

$$w_{rez}(t) + \sum_{i=1}^m w_i(t) = 1 \quad (4)$$

because the sum of all mass fractions is equal to unity. The original size material  $x_i$  (in the interval  $x_i$  to  $\mathbf{b}\cdot x_i$ ) it is outlined as whole (intact) if it is kept on the sieve  $i$  afterwards passing through the grinding procedure. Happenings that derive as the breaking of higher particles from the interval so that component of the outcome is kept in the identical interval on the sieve can't be quantified empirically and total particles that stay on the initial sieve are regarded unground (intact).

The fractional breaking rate of the material is in this case given by (Reid, 1964):

$$k_i = - \frac{dw_i(t)}{w_i(t) dt} \quad (5)$$

If it is assumed that the fractionation rate is independent of time, i.e.  $k_n = k$  for any  $n$ , we obtain as follows:

$$\frac{dw(t)}{w(t) dt} = - k \quad (6)$$

In order to acquire a mass equilibrium for the dimension  $x_i$ , we will think a tiny time increment  $dt$  in which the quantity torn as the dimension  $x_i$  is  $k_i w_i(t) dt$ . The quantity achieved from the dimension  $x_j$ ,  $j < i$ , is  $k_j w_j(t) dt$ , and the quantity achieved of entirely the aforementioned dimensions  $x_i$  is  $\sum_{j=1}^{i-1} k_j w_j(t)$ .

Examination of relation (6) leads to the outcome which in overall the rate fracture of rupture of the substance in a restricted dimension range is not distinct of time, and accordingly the supposition of time independence is, in overall theoretically void. According to particular condition the supposition is reasonable, but the chance that an empirical arrangement will precisely satisfy the restriction conditions is modest. There is a large variety of potential rupture value and rupture functions, and the degree of time addiction of the rupture value of a singular sieve dimension will rely upon on the aggregate outcome of both variables.

The level of filled in of the ball grinder also affects the efficiency of the grinder and the efficacy of crushing. When overfilling, escalating balls strike with dropping ones. The degree of filled in of the grinder,  $\varphi$ , influences the regime speed, according to the relationship:

$$n = \frac{8}{\sqrt{D}} (5\varphi + 2) \quad (7)$$

where,  $D$  is drum diameter [m];  $n$  is rotational speed [rpm].

In general, the filling of the ball mill should not exceed 30%-35% of its volume. The values of the degree of filling are:  $\varphi = 0.25-0.38$  for steel balls;  $\varphi = 0.25-0.30$  for cylindrical bars. In practice, it was observed that by decreasing the degree of filling, the yield of the mill increased by about 25%.

Exploratory research was carried out on a specimen of Portland cement clinker with an average phase composition (fig. 3), determined by X-ray diffraction: Alite - 60%; Belite-17%; Aluminates 10%; Ferrites 5%; CaO 1% (fig. 3).

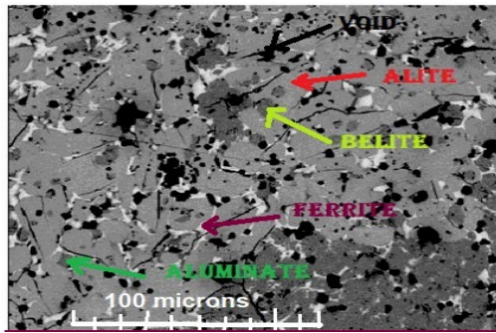


Figure 3 SEM Mineral morphology of clinker

Milling of the aforementioned material was carried out on a ball mill (barrel diameter 250 mm), loaded with steel balls with a diameter of 25 mm. To ensure optimal conditions for reducing the size of clinker grains, the count of rotation of the grind drum was 60 rpm. Experiments were performed with a mill loading of 35% balls and a particle loading of 100%. The grinding procedure was carried out in more than 15 batches, with different compositions, and the cement samples were collected at different time periods. The particle size distribution resulting from the grinding process was determined with the CILAS laser granulometric analysis device by sieving the sample for 60 seconds. Figure 4 shows the cumulative size distribution curves according to the mass fraction of particles with a size smaller than the aperture size of the sieve (passing through the sieve) of 6 samples from the total of 15 performed, which were included in our research. The data were named with the following acronyms: Cement BR 1 5-“Prob85”, Cement BR 1 10 - “Prob86”, Cement BR 1 13.5 - “Prob87”, Cement BR 1 17 - “Prob88”, Cement BR 1 20 - “Prob89” and Cement BR 2 5 - “Prob95”.

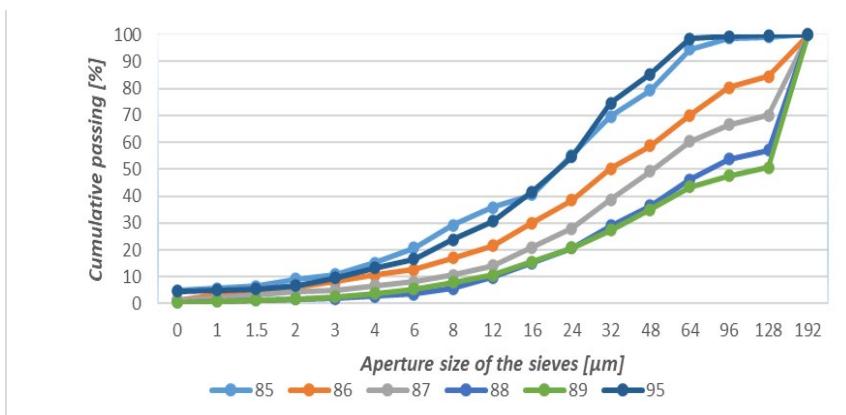


Figure 4 Cumulative curves of experimentally determined sieve passes (mass fraction of particles with a size smaller than the size of the sieve mesh depending on the mesh size of the sieves)

The characteristic parameter ( $x_{50}$ ) of the distributions presented in table 1, is the diameter corresponding to the 50% order of the granulometric curve of the ground product, and was obtained by calculation with the weighted average method:

$$x_{50} = \frac{\sum_{i=1}^n w_i \cdot x_i}{\sum_{i=1}^n w_i} \quad (8)$$

where  $x_{50}$  = weighted average;  $n$  = number of terms to be averaged;  $w_i$  = weight of fraction  $i$ ;  $x_i$  = average particle size of the fraction  $w_i$ .

**Table 1** Characteristic size  $x_{50}$  [ $\mu\text{m}$ ] of the grinded particles size distribution

Sample	Cem85	Cem86	Cem87	Cem88	Cem89	Cem95
$D_{50}[\mu\text{m}]$	27.4	47.7	66.1	118.8	174.9	28.9

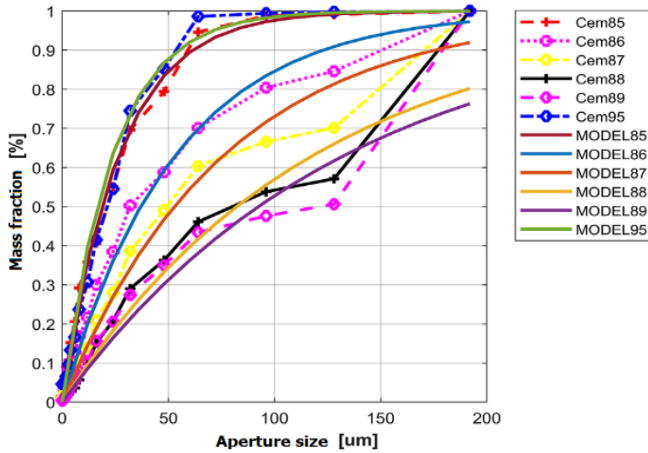
Each component in the phase composition contributes to the mechanical strength of the final clinker subjected to grinding. The proportions of each mineral in the raw material are significant in deciding the properties of the resultant cement, the main matter for the outcome being a vigorous root of calcium (Herfort and Macphee, 2019).

## RESULTS AND DISCUSSION

The mathematical analytical formulation of the ball mill particle fractionation process is based on the mass conservation law. The fractionation rate values at particle breakage were determined by the parameter estimation technique using the equation (6) model, used to describe the kinetics of batch grinding. Equation (6) is a first-order ordinary differential equation, and it was solved with the help of the program libraries provided by the Matlab package. The independent (unknown) variable is  $w_i(t)$  the mass fraction of solid particles on the sieve in size range  $i$  (delimited by the aperture size of the top sieve  $x_{i+1}$  and the aperture size of the smaller sieve  $x_i$ ), and  $t$  is the milling duration. The definition of the differential equation (6) and the symbolic solution were carried out with the following Matlab instructions:

```
syms w(t) K
ode = diff(w,t) == -w*K;
cond = w(0) == 1;
fracM = dsolve(ode,cond)
fracM = e-K*t
```

For a grinding duration of  $t=3600$  s, a discretization time step of 211 s was chosen. By imposing the limit conditions, at  $t=0$ ,  $w(t) = 0$  and at  $t = t_{\text{final}}$   $w(t) = 1$ , in the range of particle sizes 0-192  $\mu\text{m}$ , the cumulative curves of mass fractions with particle sizes smaller than the aperture size of the upper sieve (undersize particles) were determined by applying the analytical solution of equation (6).



**Figure 5** Comparison of the cumulative curves of size crossings determined with the theoretical and experimentally determined models

The graph presented in fig. 5 provides a visual comparison of the cumulative mass fraction curves determined with the experimental values and the cumulative curves determined with the proposed model.

Using the Live script editor in Matlab allows to produce scripts that join layout, text chart and equations with part of coding. Another advantage is that we can produce the interactive programme, add in control bars that offer the user to pick variable values.

When monitoring data of different variables are disposable, the model can be tested with several parameter values to test which criterion value best fulfil the observations. Subsequent to this a method the initial function of the parameters and variables is changed: presently the parameters are unidentified while the variables are now familiar. Through this justification parameter adjustment is likewise called the reverse modeling operation. To adjust the fractionation rate parameter, a Slider (Numeric Slider) was used from the toolbar, and thus, every time the slider was moved, that portion of the programme was executed again and, the graph in fig. 5 updated.

Optimal parameters adopted for the presented models are:

$$\begin{aligned} K1_{mod} &= 0.002; & K4_{mod} &= 0.00045; \\ K2_{mod} &= 0.001; & K5_{mod} &= 0.0004; \\ K3_{mod} &= 0.0007; & K6_{mod} &= 0.00225; \end{aligned}$$

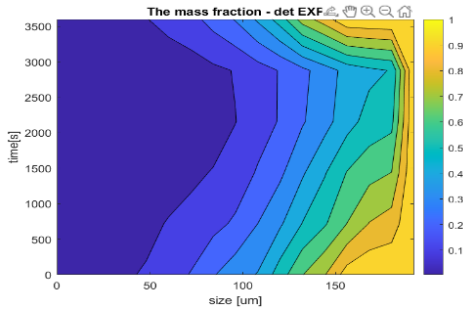
In the experiments presented in this paper, the values of the rate fracture of the clinker particles  $k$  vary, quite widely, in the range [0.0004-0.00225].

We mention that the adjustment method is developed on a numerical measure of the property of an estimation. The evaluation is developed on the residual vector, exhibit the discrepancy among the experimentally specified and the modeled values. The quality of the approximation was checked by calculating the discrepancy between the experimental and

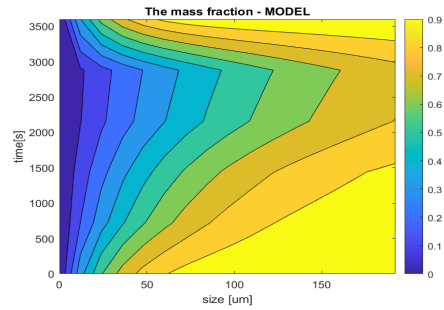
theoretical values, evaluated in the residual norm. The Euclidean norm of a vector with N items is determined by the relation:

$$\|v\| = \sqrt{\sum_{i=1}^n |v_i|^2} \tag{9}$$

For the approximation of the models presented in figure 5, the calculated norms were norm = [5.871 3.5215 3.1264 4.0825 4.7469 4.3733].

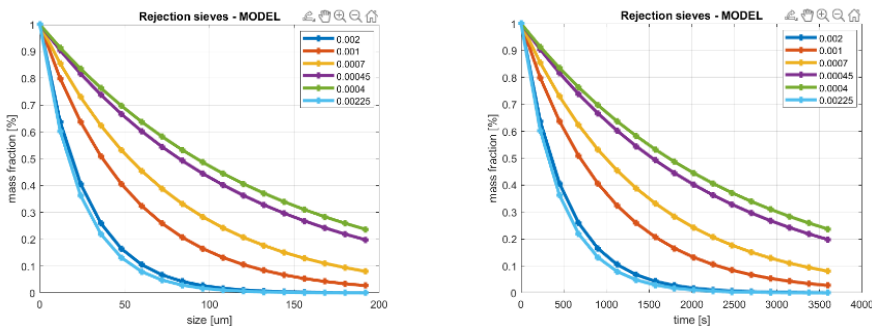


**Figure 6** The contour lines of the experimentally determined cumulative mass fraction



**Figure 7** Contour lines of the cumulative mass fraction determined with the theoretical model

The variation maps of cumulative curves for the grinded material mass fraction that is smaller than the dimension of the screen mesh depending on the two independent variables, dimension of the sieve aperture and the grinding time, obtained with the experimental and the theoretical model are presented in figures 6 and 7. Even if, obviously, according to the findings of Reid (1965), Gupta and Kapur (1975), and later Glasnovic and Hraste (1982), there are quantitative differences between the results obtained, it can be mentioned that the distribution of the fracture parameters in a first approximation is good, for a normal operating range.

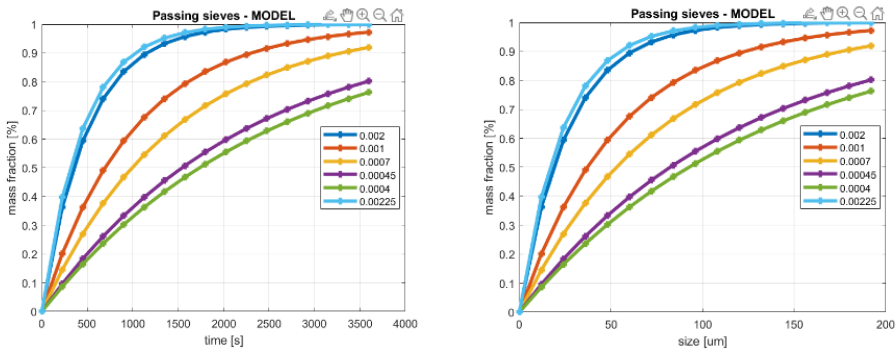


**Figure 8** Cumulative curves of sieve rejections determined with the theoretical model depending on the sieve aperture size (right) and depending on time (left)

The graphic representation in the plane of the contour lines for the mass fraction vector depending on the size [ $\mu\text{m}$ ] and  $t$  [s] variables is done by calling the `contourf` function.

The results obtained by determining with the theoretical model the fractionation rates of clinker nodules in the grinding process in the ball mill are presented in figures 8 and 9. It shows a good agreement with those presented by Gupta and Kapur (1975) or, the kinetic model being much more elastic and easier to implement than the classical generalized Rosin-Rammler distribution. It can be seen that the proposed relation explains the entire path aside from a firstly start time of the particle size range over time.

The ball diameter and the degree of ball loading are significant parameters of the excellent working of a ball mill. Thus, based on the kinetic model, the influence of the ball diameter and satisfying with fractionating balls on the breaking kinetics of the clinker powder under discontinuous grinding conditions can also be investigated (Deniz, 2013).



**Figure 9** Cumulative curves of passing sieve determined with the theoretical model depending on aperture sieves (right) and depending on time (left)

According to various explanations, the energy transformed into mechanical work for dimension decrease is between 2.5 and 19.5 % of the aggregate energy delivered to the mill grinding; the balance energy is spread in friction among particles, friction among grain and mill structure, generating noise, heat and vibration. The conceptually poor level of energy employment provided is of greater interest to the grinding plant designer. However, since the energy consumption of grinding can be considered small compared to the technological advantage of grinding, ball mills remain in the top of the preferences of cement producers.

## CONCLUSIONS

Estimating the values of the parameters of the grinding equation was not a simple task, because the tested samples showed a systematic variation in connection to the grinding duration mostly due to the different composition of the raw materials. Even so, it is required to determine appropriate recommendations for achieving the best suitable approach of the wanted variable from the values obtained in the experimental measurements.

The analytical solution method of the particle fragmentation equation presented here is very useful because it can be used for a wider variety of problems, deriving from the balance



equations of the particle population. As similar its relevance principally for simulation research is self-evident.

Both the composition of the raw materials and the mineral morphology of the resulting cement clinker significantly influence the crushing index of the material in the ball mills.

## REFERENCES

- Bwalya, M.M., Moys, M.H., Finnie, G.J., Mulenga, F.K., (2014). Exploring ball size distribution in coal grinding mills, *Powder Technology*, Vol. 257, pp. 68-73.
- Ciobanu, C., Tudor, P., Istrate, I.A., Voicu, G., (2022). Assessment of Environmental Pollution in Cement Plant Areas in Romania by Co-Processing Waste in Clinker Kilns, *Energies*, Vol. 15, 2656. <https://doi.org/10.3390/en15072656>
- Da, Y., Hea, T., Shi, C., Wang, M., Feng, Y., (2021). Potential of preparing cement clinker by adding the fluorine-containing sludge into raw meal, *Journal of Hazardous Materials*, Vol. 403.
- Deniz, V., (2012). The effects of ball filling and ball diameter on kinetic breakage parameters of barite powder, *Advanced Powder Technology*, Vol. 23, pp. 640–646.
- Glasnovic, A., Hraste, M., (1982). The grinding equation in the investigation of the coarse dispersing system of cement, *Cement and Concrete Research*. Vol. 12, pp. 415-424.
- Gupta, V.K., Kapur, P.C., (1975). A pseudo-similarity solution to the Integro-Differential equation of batch grinding, *Powder Technology*, 12, pp. 175-178.
- Gupta, V.K., Sharma, S., (2013). Analysis of ball mill grinding operation using mill power specific kinetic parameters, *Advanced Powder Technology* <http://dx.doi.org/10.1016/j.apt.2013.10.003>.
- Herfort, D., Macphee, D.E., (2019). Components in Portland Cement Clinker and Their Phase Relationships, *Lea's Chemistry of Cement and Concrete (Fifth Edition)*, pp. 57-86.
- Oseni, M.I., Okon, N.E., Ager, P., (2011). Tribological Processes in a Ball Mill for Ordinary Portland Cement Production, *Australian Journal of Basic and Applied Sciences*, Vol. 5, 12, pp. 360-365.
- Prabhakaran, S.S.P., Swaminathan, G., (2022). Thermogravimetric study of textile lime sludge and cement raw meal for coprocessing as alternative raw material for cement production using response surface methodology and neural networks, *Environmental Technology & Innovation*, Volume 25, 102100.
- Qian, H.Y., Kong, Q.G., Zhanga, B.L., (2013). The effects of grinding media shapes on the grinding kinetics of cement clinker in ball mill, *Powder Technology*, Vol. 235, pp. 422-425.
- Reid, K.J., (1964). A solution to the batch grinding equation, *Chemical Engineering Science*, Vol. 20, pp. 953-963.
- Schumacher, G., Juniper, L., (2013). Chap.15 - Coal utilisation in the cement and concrete industries, *The Coal Handbook: Towards Cleaner Production*, Volume 2 in Woodhead Publishing Series in Energy, pp. 387-426.
- Sharapov, R., (2018). Matrix model of the grinding process of cement clinker in the ball mill, *IOP Conf. Ser.: Mater. Sci. Eng.* 307 012048.
- \*\*\*<https://uk.mathworks.com/help/matlab/ref/norm> (accessed on 24 September 2022).

---

---



## IMPACT OF MAIZE, HEMP AND FABA BEAN INTERCROPPING ON THE SOIL PROPERTIES

Kęstutis ROMANECKAS, Jovita BALANDAITĖ, Austėja ŠVEREIKAITĖ,  
Algirdas JASINSKAS, Ugnius GINELEVIČIUS, Deividas PAKALNIS

E-mail of corresponding author: [kestutis.romaneckas@vdu.lt](mailto:kestutis.romaneckas@vdu.lt)

*Vytautas Magnus University, Agriculture Academy  
Studentu 11, LT 53361, Akademija, Kaunas distr., Lithuania*

### ABSTRACT

*The goal of the majority of bioenergy producers is to grow as much crop biomass as possible in the shortest possible time. However according to the requirements of the Green Deal in 2023-2027 during the period, the consumption of fertilizers and plant protection products will have to be significantly reduced. In order to fulfil all the necessary conditions for biomass production, a stationary field experiment was started in 2020 at the Experimental Station of Vytautas Magnus University, Lithuania. Cultivations of maize, technical hemp and faba bean have been investigated as single, binary and ternary crops. The purpose of this study is to find out the influence of crop biodiversity level on soil structural composition, stability, soil pH and the concentration of soil macrolelements.*

*Contrary to expectations, during vegetative seasons 2020 and 2021, at low (totally N 45, P 45, K 45 kg ha<sup>-1</sup>) fertilization level, the increase of crop biodiversity increased the amount of nitrogen in the soil. However, the levels of phosphorus and potassium decreased. Unlike expected, the volume of macro-aggregates in the soil increased in the maize and hemp single-crops. Still, the amount of micro-structure decreased higher in the ternary-crop. The structural stability of the soil depended mostly on the meteorological conditions during experiment. These findings suggest continuing investigations in the conditions of higher-level fertilization.*

**Keywords:** *Multi-functional energy cultivations, Soil pH, Soil macro-nutrients, Soil structural composition and stability.*

## INTRODUCTION

Renewable energy technologies are defined as clean energy sources that reduce environmental pollution, generate minimal secondary waste, and are sustainable for current and future societal needs (Panwar et al., 2011). It is the area of energy production that has received a lot of attention in recent years, as data on the dramatic decline of non-renewable resources reveal that fossil fuels may last for little more than the next 100 years, and while natural gas may run out in less than 50 years (Haberl et al., 2011). Due to the decrease of these resources, the increase in service prices related to the use of these resources also dependable.

In the subarctic (boreal) climate of Lithuania, with excessive humidity, the average air temperature reaches 6.2–6.7 °C, and the vegetation period lasts only 140–160 days. With such a short duration of vegetation in Lithuania, many crops with high biomass productivity potential do not manage to realize it especially maize (corn), as it is more of a southern hemisphere crop. Hemp and faba bean show their true potential during research these plants, as they are perfectly adapting to the Lithuanian climate. When growing these crops in a multi-crop, it is expected to accumulate biological nitrogen, improve soil porosity and structure, moisture content, grow a large amount of biomass, and purify the soil from diseases and heavy metals (Ghanbari et al., 2010).

Hemp, maize and faba bean were studied wide and in Lithuania in the past as single-crops, but there are few researches multi-functional crops. In 2020, faba bean crop areas in Lithuania amounted to 58,679 thousand ha, and in 2021 it jumped to 78,053 thousand ha. The area of bean crops grown in Lithuania increased by almost a third. Maize crop areas remained stable and similar. In 2020, they reached 50,666 thousand ha, in 2021 – 49,135 thousand ha. Hemp crop area in 2020 was 5,284 thousand ha, and in 2021 – 4,780 thousand ha (Lithuanian Department of Statistics, 2022).

The mentioned crops are demanding fertile soil; the pH of the soil should be in the interval 5.5–7.0; while hemp needs pH up to 7.5. In order to grow higher biomass and energy potential, these plants need sufficiently moist and structured soil. When harvesting seeds, removing the biomass of hemp and maize from the field, the physical, chemical and biological properties of the soil are affected. If the amount of humus and nutritional elements decreases, bioactivity and structure of the soil deteriorates. These effects lead to soil degradation. However, there are also benefits: increasing biodiversity, diversifying plants. It is expected that the nutritional and energetical value of the main production will improve.

The goal of the European Green Deal is to create a competitive and modern economy and production that would improve the quality of life of the future generations. Such a transition calls for a new approach to use raw materials. Plant biomass is currently the most promising renewable resource for energy production (Bhutto et al., 2019). Increasing biomass production per area unit is an increase in crop functionality when intercropping other fast growing species of agricultural plants into the main crop (Franco et al., 2015).

It is believed that many benefits can be obtained from the proper use of the technology of growing multipurpose crops technology, as each plant uses and releases different substances in its own way, and each of them provides nutrients to others in a different way. Also, certain plants repel various pests. By properly combining plants with each other, there is a possibility to abandon pesticides and fertilizers. This makes double benefits to soil and people.

We expect that diversification of maize, hemp and faba bean from single to binary and ternary-crop will improve soil properties.

## MATERIAL AND METHODS

Since 2020, a short-term stationary field experiment has been performed at the Vytautas Magnus University, Agriculture Academy research station (54°52' N, 23°49' E). The research station is located about 6 km away from Kaunas city, on the left side of the Nemunas River. The soil of this area is sandy and dusty loams, common and carbonaceous gleyic meadows, and stagnant leachate of the middle Nemunas plateau.

The soil in the experiment is a deeper gleyic saturated loam (45.6% sand, 41.7% silt, 12.7% clay) Planosol (Endohypogleyic-Eutric, *Ple-gln-w*) (WRB, 2014). Soil pH<sub>HCl</sub> varies from 7.3 to 7.8, total nitrogen content varies from 0.08 to 0.13%, humus varies from 1.5 to 1.7%, available phosphorus – from 189 to 280 mg kg<sup>-1</sup>, available potassium – from 97 to 118 mg kg<sup>-1</sup>, and exchangeable magnesium – from 436 to 790 mg kg<sup>-1</sup>.

Lithuanian climate is boreal, transitional maritime-continental with wet winters and moderate summers. During the last 60 years, annual precipitation rate in the experimental site has been 625.5 mm. In our experiment, the vegetative seasons of crop cultivations lasted 103–105 days, based on length of faba bean vegetative period (from BBCH 09–10 to BBCH 83–86). Vegetative seasons of 2020 and 2021 were uneven in terms of air temperatures and precipitations. April was colder and more arid than long-term weather conditions. May was colder also, but excessively humid. June was warmer than the long-term average (since 1974), but precipitations were distributed differently during each experimental year. Usually July is the warmest month; but in 2020, the air temperature was lower than the long-term average. In all the experimental years, this month was arid. August was uneven – in 2020 it was close to the average, in 2021 – more humid. Air temperatures in August also varied during experimental years.

Three crops were grown in the crops with different biodiversity: maize (*Zea mays* L.) (Pioneer selection), hemp (*Cannabis sativa* L.) (cultivar Austa SK) and faba bean (*Vicia faba* L.) (cultivar Vertigo). Crops were sown as single, binary and ternary crops. A total of seven treatments was tested (Table 1).

**Table 1** The treatments of experiment

Biodiversity level	Cultivation	Abbreviation
single-crop	maize	MA
	hemp	HE
	faba bean	FB
binary-crop	maize + hemp	MA+HE
	maize + faba bean	MA+FB
	hemp + faba bean	HE+FB
ternary-crop	maize + hemp + faba bean	MA+HE+FB

The plots in the experiment were distributed randomly with three replications. The initial size of the plot was 8 m<sup>2</sup>. In total, there were 21 plots in the experiment. The pre-crop was oat; after crops were reseeded (continued).

In autumn, the experimental field was deeply (22–25 cm) ploughed. In the spring, when the soil reached physical maturity, it was cultivated with a compound cultivator to a depth of 3–4 cm. After soil cultivation, mineral fertilizer NPK 5:15:30 was strewed (totally N 45, P 45, K 45 kg ha<sup>-1</sup>). Within three days at the latest, the experimental field was sown by hands following the intended sowing scheme. Later, the crops were thinned to form as uniform a crop density as possible. After the weeds sprouted abundantly, the inter-rows of the crop were weeded manually 1–2 times. The agro-technic operations and methods widely presented in the article of Romaneckas et al. (2022).

In 2020 and 2021, samples for soil aggregation and stability determination were taken after sowing, before inter-row loosening, and at the end of vegetative season in a layer of soil 0–25 cm deep in at least 4–5 spots per each plot. Composite samples were taken. A Retsch screening apparatus (RETSCH GmbH, Haan, Germany) and a set of sieves were used to determine the soil aggregate composition. The sieves had holes with diameters of 10, 7.1, 5.6, 4, 2, 1, 0.5 and 0.25 mm. The stability of the soil aggregates (wet sieving) was determined with a Retsch wet sieving device from a previously sifted dry soil fraction of 1–2 mm (Hillel, 1982).

Optimal expressions of soil structure: mega or clod structure (soil aggregates larger than 10 mm) – no more than 5 percent; macro or crumbly structure (from 0.25 to 10 mm) - more than 90%; micro or dust structure (units smaller than 0.25 mm) – no more than 5 percent. From an agronomic point of view, the best is a crumbly structure (aggregates of 0.5–5 mm). Due to a sufficient number of gaps, the pores are filled with air and water and maintain a good air-water ratio, thus creating suitable conditions for plants. Soil with optimal structure durability is when 50% or more of the soil does not disintegrate when exposed to water (Romaneckas et al., 2011).

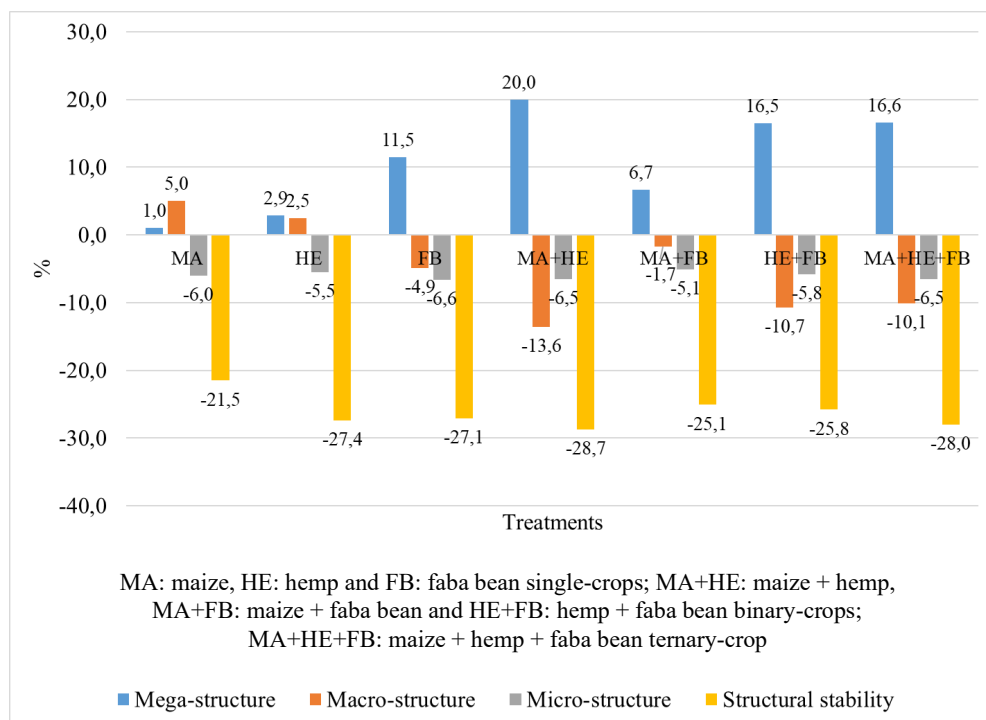
The total nitrogen content in the soil was tested according to the ISO 11261:1995 standard, available phosphorus and potassium by the Egner–Riehm–Domingo (A–L) method (LVP D-07:2016), available magnesium – by the LVP D-13:2016, and soil pH<sub>KCl</sub> by the potentiometric method (ISO 10390:2005—Soil quality and Determination of pH).

## RESULTS AND DISCUSSION

In spring 2020, in the beginning of experimentation, the soil aggregate-size distribution was similar in all experimental plots. We expected that the amount of much valuable macro-aggregates will rise with increase of biodiversity of crop. Unfortunately, the volume of macro-aggregates increased in the MA and HE single-crops (Figure 1). The amount of micro-structure decreased significantly with increase of crop biodiversity, and it was the lowest in the ternary-crop. We expected this result because higher amounts of micro-aggregates initiated water and wind erosion. Amount of mega-aggregates increased in cases, but the highest rise was in MA+HE and MA+HE+FB plots.

The structural stability of the soil decreased during two years, especially during the winter 2020/2021 and vegetative period 2021. However, the differences were insignificant. The high-level decrease of soil stability in winter could have been affected by the positive

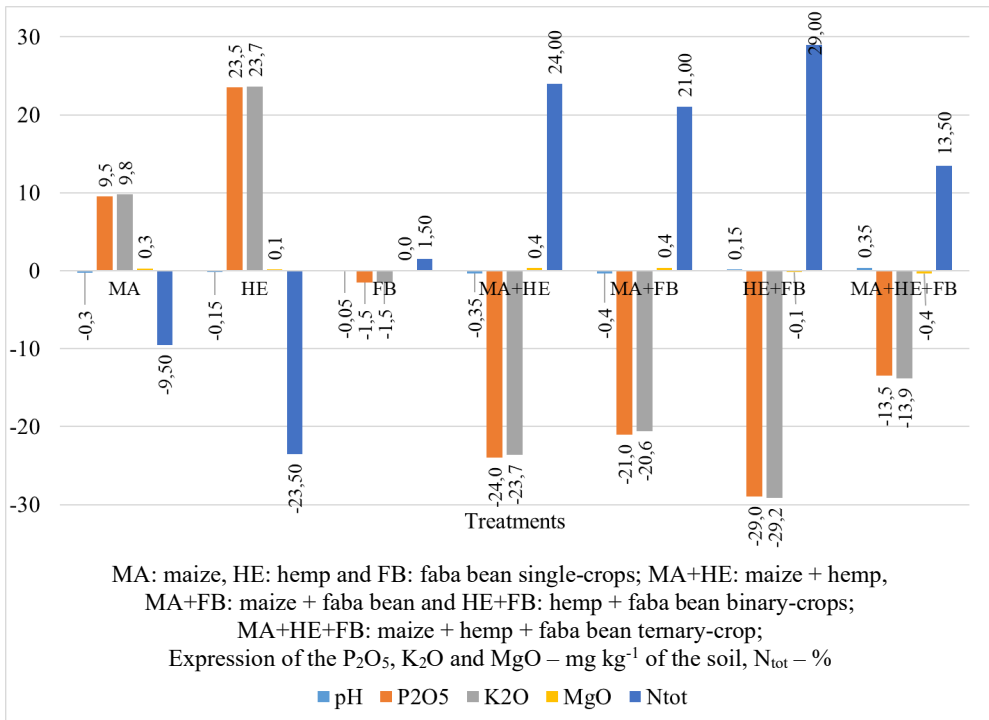
temperature of the soil under high layer of snow. In the vegetative period 2021, uneven precipitation distribution with the humid and arid periods could damaged the soil (Romaneckas et al., 2022).



**Figure 1** Changes in soil aggregate-size distribution ( $\pm$ ) from the beginning of the 2020<sup>th</sup> growing season until the end of the 2021<sup>th</sup> growing season

We expected that inter-cropping of maize, hemp with faba bean will stabilize or increase amount of macronutrients in the soil due to ecological service of faba bean (Köpke and Nemecek, 2010). Similarly it was pointed by Kader et al. (2017). They found that inter-crops (or catch crops) can maintain the fertility of soil. In our experiment, soil pH during two years of experimentation increased in HE+FB and MA+HE+FB plots (Figure 2).

According to the Brooker et al. (2015), multi-cropping systems with beans or peas requires less or no use of synthetic fertilizers. Contrary to expectations, plant-available phosphorus and potassium generally decreased in the soil, except for maize and hemp single-crops. However the amount of total nitrogen decreased in the plots of these treatments. The highest volume of total N was found in the binary-crop (MA+HE, MA+FB and HE+FB) plots. Volume of available magnesium was mainly increased during two years of experimentation with exception in the HE+FB and MA+HE+FB plots.



**Figure 2** Changes in soil pH and macronutrient contents ( $\pm$ ) from the beginning of the 2020<sup>th</sup> growing season until the end of the 2021<sup>th</sup> growing season

## CONCLUSION

In conditions of low crop fertilization level, the increase of biodiversity level in the crops did not stabilize mineral fertility of the soil effectively. Although the amount of nitrogen in the soil increased, phosphorus and potassium amounts decreased.

Unlike expected, the volume of macro-agregates in the soil increased in the MA and HE single-crops. However the amount of micro-structure decreased significantly in the ternary-crop.

The structural stability of the soil decreased during two years of experimentation because of uneven meteorological conditions: warm winter and humid-arid periods during vegetative seasons. Our findings suggest to continue investigations in the conditions of higher-level fertilization or growing multi-crops one vegetative season.



## REFERENCES

- Bhutto, A.W., Bazmi, A.A., Karim, S., Abro, R., Mazari, S.A., Nizamuddin, S. (2019). Promoting sustainability of use of biomass as energy resource: Pakistan's perspective. *Environmental Science and Pollution Research* 26(29) 29606-29619.
- Brooker, R.W., Bennett, A.E., Cong, W.-F., Daniell, T.J., George, T.S., Hallett, C.H., Iannetta, P.P.M., Jones, H.G., Karley, A.J., Li, L. et al. (2015). Improving intercropping: A synthesis of research in agronomy, plant physiology and ecology. *New Phytol.* 206 107-117.
- Franco, J.G., King, S.R., Masabni, J.G., Volder, A. (2015). Plant functional diversity improves short-term yields in a low-input intercropping system. *Agriculture, Ecosystems & Environment* 203 1-10.
- Ghanbari, A., Dahmardeh, M., Siahshar, B. A., Ramroudi, M. (2010). Effect of maize (*Zea mays* L.)-cowpea (*Vigna unguiculata* L.) intercropping on light distribution, soil temperature and soil moisture in arid environment. *Journal of Food, Agriculture & Environment* 8(1) 102-108.
- Haberl, H., Erb, K.H., Krausmann, F., Bondeau, A., Lauk, C., Muler, C., Plutzer, C., Steinberger, J. K. (2011). Global bioenergy potentials from agricultural land in 2050: Sensitivity to climate change, diets and yields. *Biomass bioenergy* 35(12) 4753–4769.
- Hillel, D. (1982). *Introduction to Soil Physics*. Academic press, INC, Harcourt Brace Jovanovich, Publishers, San Diego.
- Kader, M.A., Senge, M., Mojid, M.A., Ito, K. (2017). Recent advances in mulching materials and methods for modifying soil environment. *Soil Tillage Research* 168 155–166.
- Köpke, U., Nemecek, T. (2010). Ecological services of faba bean. *Field Crops Research* 115(3) 217–233.
- Lithuanian Department of Statistics (2022). <https://www.stat.gov.lt/en>
- Panwar, N.L., Kaushik, S.C., Kothari, S. (2011). Role of renewable energy sources in environmental protection: A review. *Renewable and Sustainable Energy Reviews* 15(3) 1513-1524.
- Romaneckas, K. (2011). The optimization of soil tillage for sugar beet. *Žemės ūkio mokslai* 18(2) 83–93 (in Lithuanian with English summary).
- Romaneckas, K., Balandaitė, J., Sinkevičienė, A., Kimbirauskienė, R., Jasinskas, A., Ginelevičius, U., Romaneckas, A., Petlickaitė, R. (2022). Short-term impact of multi-cropping on some soil physical properties and respiration. *Agronomy* 2022 12, 141. <https://doi.org/10.3390/agronomy12010141>
- World reference base for soil resources (WRB) (2014). International soil classification system for naming soils and creating legends for soil maps. *World Soil Resources Reports No. 106*. FAO, Rome.

---

---



## WINTER WHEAT PRODUCTIVITY AND PROFITABILITY AT VARIABLE SEEDING RATE AND DEPTH

Egidijus ŠARAUSKIS<sup>1\*</sup>, Marius KAZLAUSKAS<sup>1</sup>, Indrė BRUČIENĖ<sup>1</sup>,  
Kęstutis ROMANECKAS<sup>2</sup>, Vilma NAUJOKIENĖ<sup>1</sup>, Sidona BURAGIENĖ<sup>1</sup>,  
Dainius STEPONAVIČIUS<sup>1</sup>, Abdul Mounem MOUAZEN<sup>1,3</sup>

\*E-mail of corresponding author: egidijus.saruskis@vdu.lt

<sup>1</sup>Department of Agricultural Engineering and Safety, Faculty of Engineering, Agricultural Academy, Vytautas Magnus University, Studentu str. 15A, 53362 Akademija, Kaunas reg. Lithuania

<sup>2</sup>Department of Agroecosystems and soil Sciences, Faculty of Agronomy, Agricultural Academy, Vytautas Magnus University, Studentu str. 11, 53361 Akademija, Kaunas reg. Lithuania

<sup>3</sup>Department of Environment, Faculty of Bioscience Engineering, Ghent University, Coupure Links 653, 9000 Gent, Belgium

### ABSTRACT

*Precision farming technologies are gaining popularity as the cost of agricultural inputs (fuel, fertiliser, etc.) increases. Proper use of soil variability can increase crop productivity and economic efficiency. Precision seeding is precisely one of the technological operations of variable rate application. The aim of this study was to investigate the influence of variable seeding rate and variable sowing depth on the productivity parameters of winter wheat in different soil management zones (from moderate soil MZ1 to light soil MZ5) and to assess the economic benefits. Experimental field research was conducted in the northern part of Lithuania. The apparent electrical conductivity of the soil in the field was determined using scanner EM-38 MK-2. Based on this indicator, a seeding map for winter wheat was drawn up for the study field. A uniform seeding rate (162 kg ha<sup>-1</sup>) was applied in the control variant and a variable seeding rate (from 131 to 192 kg ha<sup>-1</sup>) in the other variants. The best results of the winter wheat yield and its productivity were shown by the VRDS method, which used variable rate seeding and variable depth. VRDS technology showed the most positive gross margin results (up to 28.04% compared to URS) in the fifth soil management zone MZ5, which had the lowest apparent electrical conductivity and the poorest soil fertility.*

**Keywords:** Site specific seeding, seeding depth, yield, soil management zones, gross margin.

## INTRODUCTION

Precision variable rate application technologies are gaining popularity because of their better exploitation of field soil variability (Kazlauskas et al., 2021; Šarauskis et al., 2022). Conventional uniform seeding does not consider field soil variability and therefore cannot produce an optimal plant population. As a result, plant abiotic and biotic stresses increase, seed inputs increase, yield decreases, and other agronomic and economic indicators as well (Munnaf and Mouazen, 2021). Variable rate seeding, on the other hand, allows farmers to account for soil heterogeneity and assign optimal seeding rates to each specific area of the field. The different parts of the field provide an opportunity to increase crop productivity and economic profit compared to the uniform seeding rate (URS) method (Grisso et al., 2011; Munnaf and Mouazen, 2021). Apparent soil electrical conductivity and clay content are among the most important soil properties whose variability can be used to determine plant seeding rates (da Silva et al., 2022).

Seeding is one of the most important parts of technological processes in crop production, as it directly affects seed germination, crop growth and yield, so seeding affects crop productivity and economic profit (Chen et al., 2022). Compared to local traditional farming, both precision seeding and integration of precision seeding and laser leveling increased the winter wheat yield. Precision farming methods had no negative effect on wheat grain protein content (Chen et al., 2022). There have been many reports (Matsuyama and Ookawa, 2020; Ozturk et al., 2006; Carr et al., 2003) in scientific publications that higher seeding rates increased grain yield and number of ears per square meter but decreased number of grains per ear.

Variable rate seeding technologies have not yet been studied in Lithuania, and there are few studies on this topic in other countries as well. Therefore, there are still many unanswered questions as to how technologies of variable seeding rate and simultaneously variable seeding depth affect plant productivity and economic benefits. The aim of this study was to investigate the influence of variable seeding rate and variable seeding depth on the productivity parameters of winter wheat in different soil management zones and to assess the economic benefits.

## MATERIALS AND METHODS

The experiment was conducted in 2021–2022 in a commercial field (22.4 ha) in the northern part of Lithuania with coordinates 55°67'45.5 "N 24°14'59.6 "E. The soil type in the field varied from loamy sand to sandy loam.

Four different seeding methods (Fig.1) for winter wheat (variety Skagen) were evaluated: uniform rate seeding (URS); variable rate seeding (VRS); variable rate and depth seeding (VRDS); variable rate and depth seeding and variable rate fertilization (VRDS+VRF).

Data on the spatial variability of the field were obtained by measuring the apparent electrical conductivity (ECa) of the soil with an EM-38 MK-2 scanner (Geonics Ltd, Canada). The division of soil management zones (MZ) based on differences in soil electrical conductivity was previously described by the authors (Kazlauskas et al., 2021). Based on this indicator, a seeding map for winter wheat was drawn up for the study field from moderate soil MZ1 (ECa >28.6 mS m<sup>-1</sup>), MZ2 (27.3–28.6 mS m<sup>-1</sup>), MZ3 (25.7–27.3 mS m<sup>-1</sup>), MZ4 (24.2–25.7 mS m<sup>-1</sup>), to light soil MZ5 (22.6–24.2 mS m<sup>-1</sup>). The generated variable rate seeding map was digitally transferred to the tractor computer. Winter wheat seeds were sown in the field

on 28<sup>th</sup> September 2021 with a Horsch Avatar 6.16 SD (Horsch Maschinen GmbH, Germany) seeding machine. A uniform seeding rate 162 kg ha<sup>-1</sup> was applied in the control variant (URS). The variable seeding rate ranged from 131.4 to 192.6 kg ha<sup>-1</sup>.



**Figure 1** Experimental research field with four seeding methods (1 – URS, 2 – VRS, 3 – VRDS, 4 – VRDS+VRF)

Chemical fertilizers were applied to the winter wheat crop with a Rauch Axis H50.2 centrifugal mineral fertilizer spreader based on a pre-compiled soil nutrient map. Phosphorous fertilizer NP\_12-52 (52 % P<sub>2</sub>O<sub>5</sub>) was applied next to the seeds at 100 kg ha<sup>-1</sup> in all variants during seeding process. The rest of the phosphorus fertilizer at 75 kg ha<sup>-1</sup> was spread with a fertilizer spreader at a uniform rate in the URS, VRS and VRDS variants and a variable rate in the VRDS+VRF variant. Potassium fertilizer KCL\_60 (60 % K<sub>2</sub>O) was spread with a fertilizer spreader at a uniform rate of 90 kg ha<sup>-1</sup> after seeding in the URS, VRS and VRDS variants, and at a variable rate in the VRDS+VRF. Fertilization with nitrogen N was carried out three times in the spring: 1<sup>st</sup> time – at the growth stage of 23 BBCH, the same rate of 60 kg N ha<sup>-1</sup> in all studied variants; Fertilization 2 – at the 32 BBCH stage, a variable rate of 70 kg N ha<sup>-1</sup> in the VRDS+VRF variant, and the same rate in the other variants; Fertilization 3 – at the stage of 47 BBCH variable rate of 50 kg N ha<sup>-1</sup> in VRDS+VRF and same rate in other variants. These additional fertilizations with nitrogen fertilizers at a variable rate were performed using an optical nitrogen sensor Yara N-Sensor ALS (manufactured by Tec5 GmbH, Germany and developed by Yara International ASA, Oslo, Norway). For variable rate fertilization, N-uptake and nitrogen fertilizer demand maps were made.

The seeding depth in the VRDS and VRDS+VRF variants was changed using the technology of automatic sowing depth adjustment, when ECa was measured with the help of a non-contact electromagnetic induction sensor and a variable depth adjustment map was created, according to which the sowing depth was changed. In field areas where ECa values were lower, the seeding depth (downforce) was increased, and where ECa values were higher, it was decreased. The depth distribution of winter wheat seeds in the seedbed was determined immediately after sowing in each soil MZ zone.

Winter wheat was sampled to determine yield indicators before grain harvest. Samples were taken by cutting winter wheat with a knife from a row 1.0 m long. After that, calculations were made per square meter and/or per hectare. From the collected samples, the number of

ears per m<sup>2</sup>, the number of grains per ear, the weight of 1000 grains, and the yield of wheat per hectare at 13% moisture content were determined and calculated. A total of 60 samples were taken for determination of plant productivity and yield parameters, 5 samples from each replicate from all variants with respect to MZ.

For the analysis of the economic evaluation, the income received per harvest and the cost per seed in each soil MZ and according to each sowing technology were determined. Gross margin is calculated by subtracting seed cost from revenue. Relative gross margin and increase gross margin determine all precision seeding technologies compared to URS. The price accepted to calculate revenue for winter wheat yield was 340.0 Eur t<sup>-1</sup>, while the price of winter wheat seed was 470.0 Eur t<sup>-1</sup>. The calculations did not consider fuel consumption, operating costs, labor costs, etc., as they were the same for all seeding methods. Only in the VRDS+VRF variant were costs for fertilizers included, as a variable fertilization rate was used. The average costs for fertilizers amounted to about 460.5 EUR ha<sup>-1</sup>.

Significant differences in winter wheat productivity and yield data between different seeding methods with respect to MZ were analyzed by analysis of variance (ANOVA) using Tukey's HSD<sub>05</sub> test at 95% probability level to compare means.

## RESULTS AND DISCUSSION

### *Variable rate seeding and variable depth*

After soil scanning in the research field, according to the ECa results, a winter wheat variable rate seeding map was drawn up. The control seeding variant used a uniform seeding rate (URS) of 162 kg ha<sup>-1</sup> throughout the field, while VRS, VRDS and VRDS+VRF each soil zone of the field used a variable seeding rate: MZ1 seeding rate varied from 131 to 162 kg ha<sup>-1</sup>, MZ2 – 138–162 kg ha<sup>-1</sup>, MZ3 – 162 kg ha<sup>-1</sup>, MZ4 – 162–177 kg ha<sup>-1</sup>, and MZ5 – 162–193 kg ha<sup>-1</sup>.

The depth of the seed insertion was measured after winter wheat seeding with variable seeding rate and variable depth. As expected, seed embedment depth was not uniform in different MZs of the field soil. However, the seeding depth met the requirements for winter wheat seeding (about 30 mm). The deepest (30.71 mm) seeds were inserted in the MZ5 zone, where the soil was the lightest, and the shallowest (25.08 mm) seeds were inserted in the MZ1 zone, where the soil was the heaviest, compared to the other zones. In the intermediate zones, MZ2, MZ3, and MZ4, the seeding depth varied 26.29, 28.25, and 27.18 mm, respectively.

### *Influence of seeding methods on winter wheat productivity parameters*

After analysis of winter wheat yield and its productivity parameters, it was found that the highest average grain yield was obtained in the MZ2 zone (Table 1), where both VRDS (9.432 t ha<sup>-1</sup>) and VRDS+VRF (9.709 t ha<sup>-1</sup>) variants of grain the yield was higher than URS and VRS, 9.212 and 8.074 t ha<sup>-1</sup>, respectively. The lowest grain yields were determined in marginal field zones MZ1 and MZ5, respectively 6.952 and 7.324 t ha<sup>-1</sup> on average. When evaluating grain yield across the field, it was seen that the best yield results were achieved with the VRDS method, which used variable seeding rate and variable seeding depth. The yield results correspond well with winter wheat yields obtained in this region. Poškus et al. (2022) found that depending on the variants, winter wheat yield varied from 6.166 to 7.253 t ha<sup>-1</sup>.

**Table 1** Effect of seeding technology and soil MZ on winter wheat yield and its productivity parameters

Seeding technology	MZ	Seed rate, t ha <sup>-1</sup>	Number of ears per m <sup>2</sup>	Number of grains per ear	Weight of 1000 grains, g	Grain yield, t ha <sup>-1</sup>
URS		0.162	585b	31.05b	37.65a	6.951b
VRS		0.131	558ab	33.79c	38.92b	7.395b
VRDS		0.131	696c	32.47c	37.23a	8.372c
VRDS+VRF	MZ1	0.131	510a	27.05a	36.88a	5.089a
Average of VRS, VRDS, VRDS+VRF		0.131	588	31.10	37.68	6.952
HSD <sub>05</sub>			60.07	1.33	1.00	0.869
URS		0.162	621b	38.51c	38.39a	9.212b
VRS		0.138	570a	36.47b	38.84a	8.074a
VRDS		0.138	678c	36.10b	38.49a	9.432b
VRDS+VRF	MZ2	0.138	828d	33.69a	34.80b	9.709b
Average of VRS, VRDS, VRDS+VRF		0.138	692	35.42	37.38	9.072
HSD <sub>05</sub>			48.70	0.67	1.17	0.819
URS		0.162	541a	37.44a	40.11a	8.069a
VRS		0.162	601a	35.55a	38.94ab	8.414a
VRDS		0.162	660a	34.17a	39.54ab	8.817a
VRDS+VRF	MZ3	0.162	584a	35.92a	37.22b	7.757a
Average of VRS, VRDS, VRDS+VRF		0.162	615	35.22	38.57ab	8.330
HSD <sub>05</sub>			127.18	4.20	2.55	1.806
URS		0.162	684b	35.74ab	40.72a	9.932b
VRS		0.177	573a	34.84ab	38.24ab	7.722a
VRDS		0.177	652ab	36.47b	37.71b	8.993ab
VRDS+VRF	MZ4	0.177	575a	33.45a	39.00ab	7.503a
Average of VRS, VRDS, VRDS+VRF		0.177	600	34.92	38.31ab	8.073
HSD <sub>05</sub>			98.03	2.67	2.57	1.738
URS		0.162	476a	33.69b	39.05ab	6.231a
VRS		0.193	536ab	31.64a	38.68a	6.494a
VRDS		0.193	560b	35.77c	39.58ab	7.958b
VRDS+VRF	MZ5	0.193	594b	31.19a	40.65b	7.518b
Average of VRS, VRDS, VRDS+VRF		0.193	563	32.87	39.64ab	7.324
HSD <sub>05</sub>			67.26	2.00	1.70	0.861

The results of grain yield parameters showed that a higher number of ears per square meter correlated well with grain yield in individual field zones. The highest number of ears (828 ears m<sup>-2</sup>) was determined in zone MZ2 using VRDS+VRF technology. However, in the same zone, the number of grains per ear and the weight of 1000 grains were the lowest compared to other seeding technologies. The highest number of grains per ear, on average 38.51, was determined in the URS technology in the MZ2 zone. In the lightest and poorest soil zone MZ5, the lowest average number of ears per square meter was obtained, but it had the highest weight of 1000 grains. Variable seeding rates and variable depth technologies in the poorest soil in MZ showed the best result of grain yield increase compared to other zones of higher soil fertility. Poškus et al. (2022) conducted research and found that the number of ears of winter wheat per m<sup>2</sup> varied from 572 to 676, the number of grains per ear – from 41.0 to 46.7, and the weight of 1000 grains varied from 36.16 to 40.85 g. The data of these scientists agree well with the productivity parameters obtained in our study.

Comparing the results of winter wheat grain yield and its productivity obtained in our study with the results of other studies, it was observed that the established dependencies are very similar to those obtained by other authors. Matsuyama and Ookawa (2020) reported that wheat seeding rate significantly affected the number of ears per square meter and the number of grains per ear. As the seeding rate decreased, the number of ears per square meter decreased, but the number of grains per ear increased. Wheat grain yield was not significantly affected by seeding rate (Matsuyama and Ookawa, 2020). Wang et al. (2021) found that by increasing the seeding rate from 150 to 300 kg ha<sup>-1</sup>, the winter wheat grain yield increased from 7285 to 8456 kg ha<sup>-1</sup> in 2017 and from 6306 to 7417 kg ha<sup>-1</sup> in 2018. A stronger increase in the seeding rate up to 450 kg ha<sup>-1</sup> the grain yield began to decrease.

### ***Cost-benefit analysis***

Economic efficiency is very important in the application of precision agricultural technologies. The results of the cost-benefit analysis showed that in the MZ1 zone of the soil, the highest revenue of 2846.31 Eur ha<sup>-1</sup> was obtained by applying VRDS technology. Increase gross margin between VRDS and URS was 21.73% (Table 2). VRS technology also showed a positive economic effect in this zone. Although a negative gross margin was obtained when applying VRDS+VRF technology, the average relative gross margin of all precision sowing technologies was 14.25 Eur ha<sup>-1</sup> higher than URS.

In the second MZ2 zone, in all seeding technologies, both the yield and the revenue of winter wheat were higher than in the MZ1 zone. Comparing the seeding technologies, it was found that the highest revenue (3300.92 Eur ha<sup>-1</sup>) was applied with VRDS+VRF technology, gross margin was 5.90 % higher than URS. Compared to URS, a positive relative gross margin was also obtained using VRDS seeding technology, but negative gross margin indicators were obtained in VRS technology.

In the third zone of MZ3, where the same seeding rate was applied in all sowing technologies, the best gross margin results were demonstrated by VRDS and VRS technologies, where the relative gross margin was higher than in URS technology, 254.53 and 117.53 Eur ha<sup>-1</sup>, respectively. Average gross margin indicators of all variable seeding rate and variable depth technologies were 3.33% better than URS technology.



**Table 2.** Indicators of cost-benefit analysis according to seeding technologies and soil MZ

Seeding technology	MZ	Seed rate, t ha <sup>-1</sup>	Seed cost, Eur ha <sup>-1</sup>	Yield, t ha <sup>-1</sup>	Revenue, Eur ha <sup>-1</sup>	Gross margin, Eur ha <sup>-1</sup>	Relative gross margin <sup>a</sup> , Eur ha <sup>-1</sup>	Increase gross margin <sup>a</sup> , %
URS	MZ1	0.162	76.14	6.951	2363.68	2287.54	0.00	0.00
VRS	MZ1	0.131	61.76	7.395	2514.20	2452.44	164.90	7.21
VRDS	MZ1	0.131	61.76	8.372	2846.31	2784.55	497.01	21.73
VRDS+VRF	MZ1	0.131	61.76	5.089	1730.12	1668.37	-619.17	-27.07
<b>Average of VRS, VRDS, VRDS+VRF</b>		0.131	61.76	6.952	2363.54	2301.79	14.25	0.62
URS	MZ2	0.162	76.14	9.212	3131.91	3055.77	0.00	0.00
VRS	MZ2	0.138	64.72	8.074	2745.23	2680.51	-375.26	-12.28
VRDS	MZ2	0.138	64.72	9.432	3207.02	3142.30	86.53	2.83
VRDS+VRF	MZ2	0.138	64.72	9.709	3300.92	3236.21	180.44	5.90
<b>Average of VRS, VRDS, VRDS+VRF</b>		0.138	64.72	9.072	3084.39	3019.67	-36.10	-1.18
URS	MZ3	0.162	76.14	8.069	2743.32	2667.18	0.00	0.00
VRS	MZ3	0.162	76.14	8.414	2860.90	2784.76	117.58	4.41
VRDS	MZ3	0.162	76.14	8.817	2997.85	2921.71	254.53	9.54
VRDS+VRF	MZ3	0.162	76.14	7.757	2637.35	2561.21	-105.97	-3.97
<b>Average of VRS, VRDS, VRDS+VRF</b>		0.162	76.14	8.330	2832.03	2755.89	88.71	3.33
URS	MZ4	0.162	76.14	9.932	3376.88	3300.74	0.00	0.00
VRS	MZ4	0.177	83.33	7.722	2625.58	2542.25	-758.49	-22.98
VRDS	MZ4	0.177	83.33	8.993	3057.62	2974.29	-326.45	-9.89
VRDS+VRF	MZ4	0.177	83.33	7.503	2551.12	2467.79	-832.95	-25.24
<b>Average of VRS, VRDS, VRDS+VRF</b>		0.177	83.33	8.073	2744.77	2661.44	-639.30	-19.37
URS	MZ5	0.162	76.14	6.231	2118.61	2042.47	0.00	0.00
VRS	MZ5	0.193	90.52	6.494	2208.10	2117.57	75.10	3.68
VRDS	MZ5	0.193	90.52	7.958	2705.65	2615.13	572.66	28.04
VRDS+VRF	MZ5	0.193	90.52	7.518	2556.26	2465.73	423.26	20.72
<b>Average of VRS, VRDS, VRDS+VRF</b>		0.193	90.52	7.324	2490.00	2399.48	357.01	17.48

<sup>a</sup> compared to URS in each individual zone

In the MZ4 and MZ5 zones, the economic efficiency results were opposite. If URS showed the best economic results in the MZ4 zone, then in the MZ5 zone all variable seeding rate and variable depth technologies recorded better results than the uniform seeding technology. In zone MZ5, which had the poorest and lightest soil, precision technology showed the best results compared to other field zones. In this MZ5 zone, the average gross margins of all variable seeding rate and variable depth technologies were significantly 17.48% better than URS.

Variable rate seeding options improved overall production profit. Studies by other authors (Munnaf and Mouazen, 2021; Munnaf et al., 2022) have also shown that VRS technology increases economic returns compared to URS. Despite the costs of soil variable mapping, which can tentatively be from 16 to 25 Eur ha<sup>-1</sup> per year, VRS can still give a higher conditional profit for the cultivation of various crops than URS. The results of Munnaf et al. (2022) revealed that the application of site-specific seeding increased maize grain yield by 0.25–0.70 Mg ha<sup>-1</sup> and thus increased the gross margin by 26.7–92.67 Eur ha<sup>-1</sup> compared to URS. Analysis of the economic benefits of seeding showed that precision seeding of winter wheat increased the benefit-cost ratio by 7.3% (Chen et al., 2022).

## CONCLUSIONS

Precision seeding methods have effect on the winter wheat yield and its productivity parameters. Compared to URS, the variable seeding rate and variable depth method (VRDS) showed the best results for winter wheat productivity. Winter wheat yield was better in VRDS technology in a total of four from five field MZ zones compared to URS. The lowest average number of ears and the highest weight of 1000 grains were in the MZ5 zone, the lowest number of grains per ear was in the MZ1 zone. Productivity results showed that the highest average number of ears per square meter and the highest average grain yield were in MZ2 zone, 692 ears m<sup>-2</sup> and 9.072 t ha<sup>-1</sup>, respectively.

The results of the cost-benefit analysis showed different gross margin indicators in different field zones. Variable seeding rates and variable depth technologies showed the most positive results in the fifth soil management zone MZ5, which had the lowest electrical conductivity and the poorest soil fertility. After analysis of the results of economic efficiency of seeding technologies, it was found that the best gross margin indicators were achieved by applying variable rate and depth seeding (VRDS) technology. This technology produced a positive return compared to URS in four of five zones. Using the VRS technology, positive economic evaluation results were achieved in three MZ zones, while applying VRDS+VRF only in two MZ zones.

## ACKNOWLEDGMENT

This study was supported by European Regional Development Fund (project No. 01.2.2-LMT-K-718-03-0041) under grant agreement with the Lithuanian Science Council (LMTLT).

## REFERENCES

- Carr, P. M., Horsley, R. D., Poland, W. W. (2003). Tillage and seeding rate effects on wheat cultivars: II. Yield components. *Crop Science*, 43, 210–218.
- Chen, J., Zhao, C., Jones, G., Yang, H., Li, Z., Yang, G., Chen, J., Wu, Y. (2022). Effect and economic benefit of precision seeding and laser land leveling for winter wheat in the middle of China. *Artificial Intelligence in Agriculture*, 6, 1–9.
- da Silva, E. E., Baio, F. H. R., Teodoro, L. P. R., Campos, C. N. S., Plaster, O. B., Teodoro, P. E. (2022). Variable-rate seeding in soybean according to soil attributes related to grain yield. *Precision Agriculture*, 23(1), 35–51.
- Grisso, R., Alley, M., Thomason, W., Holshouser, D., Roverson, G. T. (2011). Precision farming tools: Variable-rate application Virginia Cooperative Extension, 1–7. Retrieved from [www.ext.vt.edu](http://www.ext.vt.edu).
- Kazlauskas, M., Šarauskius, E., Romaneckas, K., Steponavičius, D., Jasinskas, A., Naujokienė, V., Bručienė, I., Žiogas, T., Vaicekauskas, D., Anušauskas J., Mouazen, A. M. (2021). Effect of variable rate seeding on winter wheat seedbed and germination parameters using soil apparent electrical conductivity. In *Proceedings of the Engineering for Rural Development: 20<sup>th</sup> International Scientific Conference, Engineering for Rural Development, Jelgava, Latvia, 26–28*.
- Matsuyama, H., Ookawa, T. (2020). The effects of seeding rate on yield, lodging resistance and culm strength in wheat. *Plant Production Science*, 23(3), 322–332.
- Munnaf, M. A., Haesaert, G., Mouazen, A. M. (2022). Site-specific seeding for maize production using management zone maps delineated with multi-sensors data fusion scheme. *Soil and Tillage Research*, 220, 105377.
- Munnaf, M. A., Mouazen, A. M. (2021). Optimising site-specific potato seeding rates for maximum yield and profitability. *Biosystems Engineering*, 212, 126–140.
- Poškus, K., Brazienė, Z., Staugaitis, G., Aleknavičienė, L. (2022). Influence of different forms of sulphur fertilizers on the content of mineral nitrogen in the soil and productivity of winter wheat. *Proceedings of Conserving Soils and Water: 7<sup>th</sup> International Scientific Conference, Conserving Soils and Water 2022, Varna, Bulgaria, 5–7*.
- Šarauskius, E., Kazlauskas, M., Naujokienė, V., Bručienė, I., Steponavičius, D., Romaneckas, K., Jasinskas, A. (2022). Variable Rate Seeding in Precision Agriculture: Recent Advances and Future Perspectives. *Agriculture*, 12(2), 305.
- Ozturk, A., Caglar, O., Bulut, S. (2006). Growth and yield response of facultative wheat to winter sowing, freezing sowing and spring sowing at different seeding rates. *Journal of Agronomy and Crop Science*, 192, 10–16.
- Wang, Z., Khan, S., Sun, M., Ren, A., Lin, W., Ding, P., Noor, H., Yu, S., Feng, Y., Wang, Q., Gao, Z. (2021). Optimizing the Wheat Seeding Rate for Wide-Space Sowing to Improve Yield and Water and Nitrogen Utilization. *International Journal of Plant Production*, 15(4), 553–562.

---

---



## INFLUENCE OF POTATO WEED MANAGEMENT ON YIELD AND QUALITY OF POTATO

Jaroslav ČEPL\*, Pavel KASAL, Andrea SVOBODOVA

\*E-mail of the corresponding author: cepl@vubhb.cz

Potato Research Institute, Dobrovského 2366, 580 01 Havlíčkův Brod, Czech Republic

### ABSTRACT

*In the field trials performed between the years 2019 and 2021 the effect of weeds was investigated on potato yield and quality and at the same time the effect of selected herbicide active ingredients used prior to potato crop emergence or early after the emergence was determined. Weed infestation is highly current topics in the conditions of applied potato growing technologies in the Czech Republic. The transfer to de-stoning technology at the end of the last century meant a reduction of mechanical tuber damage; however, it excluded mechanical destruction of weeds. In the trials following active ingredients were used: flurochloridone, metribuzin + prosulfocarb, metribuzin + clomazone, metribuzin + flufenacet, aclonifen, metribuzin + flufenacet + aclonifen, metobromuron + prosulfocarb, metobromuron + aclonifen. All tested variants of herbicide active ingredients and their combinations provided a good weed control efficacy. The trial variants had a highly significant effect on potato yield. Compared to non-treated control potato yield was increased in the range of 44.1 % (metribuzin + prosulfocarb) and 112 % (metobromuron + aclonifen). An application of metribuzin + prosulfocarb combination early after emergence had a negative impact on potato growth and it resulted in low potato yield insignificant across years with non-treated control in contrast with all other variants. The highest potato yield and corresponding high weed control efficacy was determined in variants with metabromuron combinations (Var. 9 metabromuron + prosulfocarb and Var. 10 metabromuron + aclonifen). The evaluated variants had no impact on studied quality indices (tuber size distribution after harvest and starch content).*

**Keywords:** potato, weed, yield, herbicides

## INTRODUCTION

Weed control in potatoes is an important part of all growing procedures. Several authors even mention that weeds are a main limiting factor of potato production (El-Ganainy, et al. 2022) and at the same time they are a main biotic constraint of crop production (Ramesh et al., 2021). Weeds compete with potato plants considering all growth and developmental conditions. They take moisture and nutrients, and this results in much faster growth of weeds and also a higher competition ability, they shade young potato plants and deprive them of sunlight, complicate harvest, increase risk of mechanical tuber damage at harvest. It is especially significant in ecological farming technologies, where synthetic herbicides could not be used. On contrary, in the Czech Republic the decisive part of production is grown in specialized enterprises in the Bohemian-Moravian Highland, where potato area is larger than 100 ha. Due to high stone content in the soil destoning technology is applied (Čepl and Kasal, 2001). Although due to implementation of EU strategy Farm to Fork (2020) the verification of the system of mechanical cultivations is initiated, applying herbicides is still the dominant measure of weed elimination. The data on the effect of weed control on potato yield differ, they mostly range between 30 and 40 %. Ilic et al. (2016) refers that potato yield was 32 % higher in the variant of herbicide applications compared to the yield of non-treated experimental variants. Mean number of tubers per plant, recorded for the variants of herbicide application, was 40 % increased compared to tuber number in non-treated variants. Zarzecka et al. (2020) refer an increase of marketable potato yield based on applied herbicides in the range of 27.5-61 %, however, values exceeding 80 % of potato yield reduction between herbicide non-treated and treated variant are not an exception (Felix et al., 2011). Herbicide tolerance is also an important factor differing among cultivars (Luz et al., 2018). The study of the effect of pre-emergent herbicides in potatoes should continue.

## MATERIALS AND METHODS

A trial was established in 2019, 2020 and 2021 on the fields of Potato Research Station belonging to Potato Research Institute Havlíčkův Brod that is located at altitude of 465 m. The soil type was *cambisol*, *pseudogley* and medium sandy loam. Potato cultivar Dali (early, table) was planted at spacing of 750 x 290 mm. Trial plot size was 20.9 m<sup>2</sup> (2.25 m x 9.3 m) involving 96 plants based on randomized complete block system in three replications. Trial variants are presented in Table 1. Herbicide active ingredients were applied based on the methodological recommendations and product labels.

Ten days prior to trial harvest (75 days after herbicide applications) weed sampling was done in each variant and replication; total weed number and fresh weight is given in Table 2.

The results given in Table 2 show a high weed control efficacy of all evaluated herbicides. The highest efficacy was recorded for metribuzin + flufenacet combination (Var. 8) and also for flurochloridone (Var. 2) that must be applied based on the recommendations at latest 3 days after planting due to possible phytotoxic signs on emerging potato plants after a delayed application. A high weed control efficacy was also found in both combinations with metabromuron (Var. 9 and 10).

**Table 1** Basic data on applied variants

Var.	Herbicide applied	Product applied	Content of a.i.	Product rate	Application method*	Days after planting (DAP)
1	Non-treated control					
2	Flurochloridon	Racer 25 EC	250 g L <sup>-1</sup>	2.0 L ha <sup>-1</sup>	PRE	3
3	Metribuzin Prosulfocarb	Arcade 880 EC	80 g L <sup>-1</sup> 800 g L <sup>-1</sup>	4.0 L ha <sup>-1</sup>	PRE	15
4	Metribuzin Prosulfocarb	Arcade 880 EC	80 g L <sup>-1</sup> 800 g L <sup>-1</sup>	4.0 L ha <sup>-1</sup>	POST	35
5	Metribuzin Clomazone	Sencor Liquid Command 36 CS	600 g L <sup>-1</sup> 360 g L <sup>-1</sup>	0,6 L ha <sup>-1</sup> 0.2 L ha <sup>-1</sup>	PRE	15
6	Metribuzin Flufenacet	Plateen 41,5 WG	175 g kg <sup>-1</sup> 240 g kg <sup>-1</sup>	2.5 kg.ha <sup>-1</sup>	PRE	15
7	Aclonifen	Bandur	600 g L <sup>-1</sup>	4.0 L ha <sup>-1</sup>	PRE	15
8	Metribuzin Flufenacet Aclonifen	Plateen 41,5 WG Bandur	175 g kg <sup>-1</sup> 240 g kg <sup>-1</sup> 600 g L <sup>-1</sup>	2.0 kg.ha <sup>-1</sup> 2.0 L ha <sup>-1</sup>	PRE	15
9	Metabromuron Prosulfocarb	Proman Roxy 800 EC	500 g L <sup>-1</sup> 800 g L <sup>-1</sup>	2.5 L ha <sup>-1</sup> 2.5 L ha <sup>-1</sup>	PRE	15
10	Metabromuron Aclonifen	Proman Bandur	500 g L <sup>-1</sup> 600 g L <sup>-1</sup>	2.5 kg.ha <sup>-1</sup> 2.0 kg.ha <sup>-1</sup>	PRE	15

\*PRE – Herbicide applied at the pre-emergent stage

POST – Herbicide applied at the post-emergent stage of crop and weeds

**Table 2** Weed occurrence prior to harvest

Variant	2019		2020		2021		Mean of years	
	Pieces	Fresh weight (g)	Pieces	Fresh weight (g)	Pieces	Fresh weight (g)	Pieces	Fresh weight (g)
1	198	1319	106	1362	348	4844	217.33	2508.33
2	1	8	3	4	3	71	2.33	27.67
3	2	7	0	0	4	145	2.00	50.67
4	25	153	3	67	7	165	11.67	128.33
5	13	67	0	0	100	1464	37.67	510.33
6	13	62	0	0	50	540	21.00	200.67
7	33	169	0	0	3	27	12.00	65.33
8	4	19	0	0	0	0	1.33	6.33
9	3	14	2	5	10	110	5.00	43.00
10	29	150	6	7	0	0	11.67	52.33

## RESULTS AND DISCUSSION

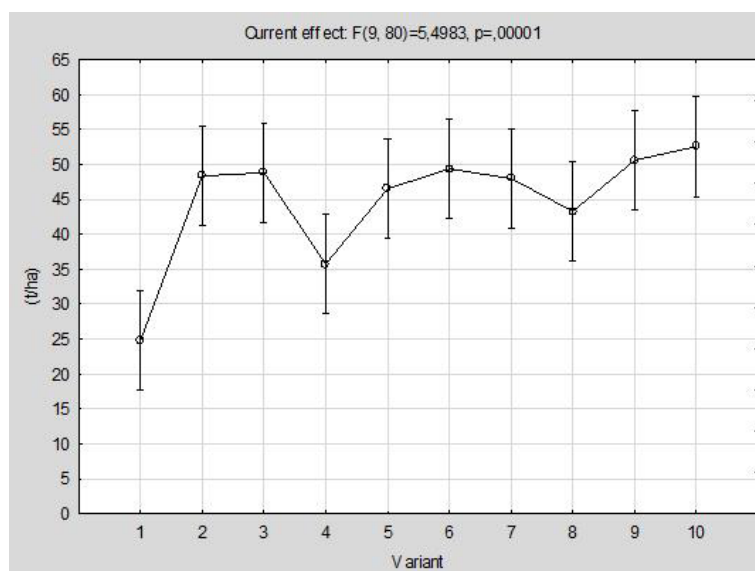
As expected, the lowest potato yields (Table 3 and Figure 1) were recorded for the non-treated variant; however, the amount of differences compared to herbicide variants was dependent on the weed occurrence. It was especially apparent in 2021 with the lowest number and weight of weeds on area unit (4,844 g m<sup>-2</sup>), when the yield of 5.93 t ha<sup>-1</sup> was only obtained on non-treated plot (Var. 1) and a high weed control efficacy of herbicides increased potato yield in the range of 21.66 t ha<sup>-1</sup> (Var. 4) and 60.84 t ha<sup>-1</sup> (Var. 10). However, it is an extreme case. The statistical assessment of individual years shows that in 2019 all evaluated variants gave a significantly increased yield, except for the variant 4, in that early post-emergent application (metribuzin + prosulfocarb) was done and this had a negative impact on further growth and crop development. In 2020, when a higher yield was also obtained in non-treated variant, differences did not reach significant values, but in mentioned 2021, with an extreme weed infestation, significant differences were again found, not only to non-treated control, but also to Var. 4 (post-emergent application) and surprisingly in variants with the highest yield (Var. 6, 7 and 10) and also to the Var. 8, where a high weed control efficacy was measured.

**Table 3** The effect of variants on potato yield (t ha<sup>-1</sup>) and weed control efficacy (%)

Var.	Trial year							
	2019		2020		2021		Mean of years	
	Potato yield	Efficacy	Potato yield	Efficacy	Potato yield	Efficacy	Potato yield	Efficacy
1	21.04	0.00	47.42	0.00	5.93	0.0	24.80	0.00
2	40.53	92.62	53.61	13.06	50.96	759.9	48.37	195.03
3	45.78	117.60	57.08	20.38	43.56	635.1	48.81	196.80
4	31.16	48.09	54.40	14.71	21.66	265.5	35.74	144.11
5	43.26	105.62	53.39	12.60	42.89	623.8	46.51	187.55
6	39.10	85.86	54.58	15.09	54.38	817.7	49.35	199.01
7	34.93	66.04	51.52	8.64	57.49	870.2	47.98	193.47
8	39.95	89.88	52.88	11.51	36.99	524.2	43.27	174.49
9	46.27	119.93	57.01	20.23	48.46	717.7	50.58	203.95
10	39.22	86.41	57.60	21.47	60.84	926.7	52.55	211.91

The results assessed across the years confirm findings from individual years (Figures 2-4), from that a summary could be derived that all products and combinations had a significant effect on potato yield. Var. 4 with a post-emergent application, had tendentially a lower yield compared to the other variants. On contrary, both evaluated combinations with metabromuron (Var. 9 metabromuron + prosulfocarb and Var. 10 metabromuron + aclonifen) could be recommended.





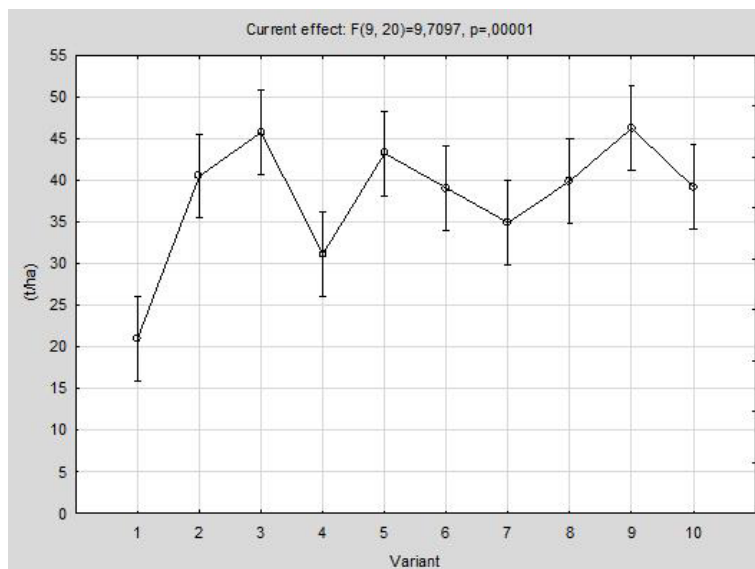
**Figure 1** The effect of variants on potato yield ( $\text{t ha}^{-1}$ ) on average of years 2019-2021

A high efficacy of metabromuron is also confirmed by Bergmann (2016) who studied the efficacy of herbicides on individual weed species, total potato yield ( $\text{t ha}^{-1}$ ) and marketable ( $> 35 \text{ mm}$ ) potato yield ( $\text{t ha}^{-1}$ ).

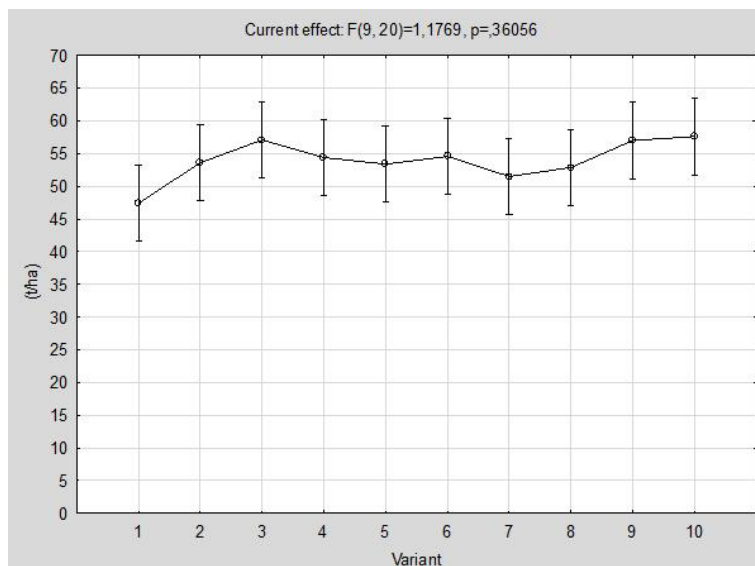
An application of flurochloridone could be also recommended, that has limitations in application date (at latest 3 DAP); however, this active ingredient is permitted for applications in protection zones of drinking water sources in the Czech Republic (Kasal, 2021). In the trial conditions, satisfactory efficacy of metribuzin combined with clomazone was also not confirmed. It is a standard combination and most distributed herbicide combination in agricultural practice not only in the Czech Republic. On contrary, Gitsopoulos et al. (2014) refer to the high efficacy of metribuzin and prosulfocarb combination and they achieved 87 % efficacy. It was certainly reflected in potato yields, which also belonged to almost the highest ones. These findings are also confirmed by many authors, since metribuzin belongs to the most used active ingredients worldwide. For example, Luz et al. (2018) found that the greatest “total” yields were observed in treatments with metribuzin. Murray (1994) also confirms that treatments with metribuzin tended to have high potato yields. The differences in assessment could also arise from conditions of various weed range on trial localities. It would also explain a reduced efficacy of metribuzin + clomazone combination. Clomazone should strengthen the effect on *Galium aparine* and grass weeds, which were not detected in our trials. El-Ganainy et al. (2022) could demonstrate an excellent efficacy of clomazone on broadleaf and grass weeds compared to unweeded and mechanically treated plots. The herbicide increased potato yield, sugar and starch content compared to non-treated control, but to lesser extent than mechanical treatment.

Var. 8 (metribuzin + flufenacet) should be evaluated in detail, which had the highest weed control efficacy (Table 2); however, it was not reflected in potato yields. On contrary, it tendentially reached lower yields compared to the other variants. For example, Klara and

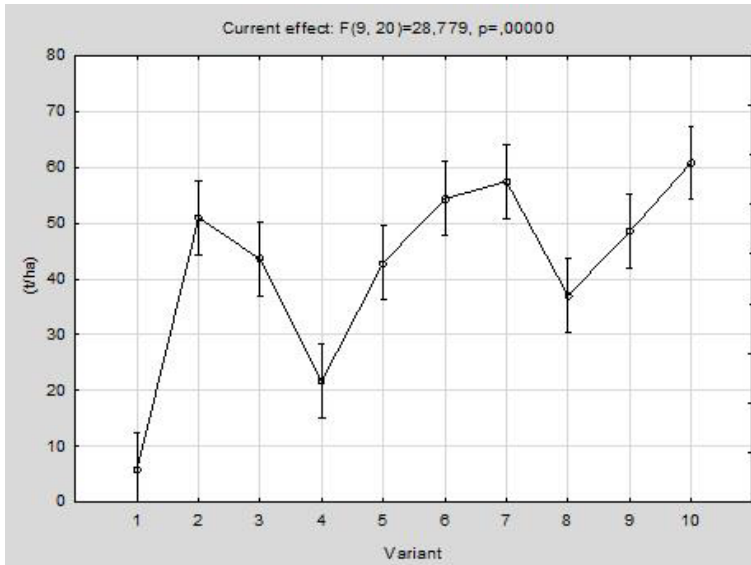
Zvonimir (2004) also confirm a high efficacy of the combination and Abdalah et al. (2021) refer that mixture of flufenacet and metribuzin have proved to be a very good and selective herbicide for control of a wide array of annual weeds in potato.



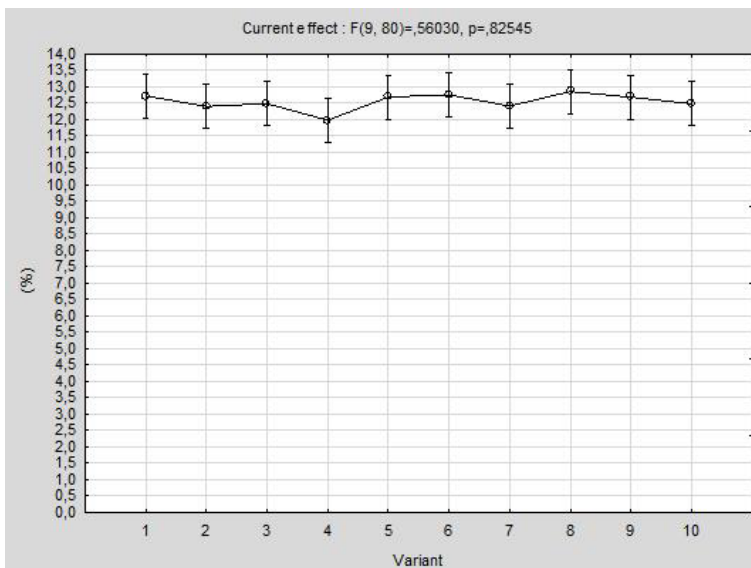
**Figure 2** The effect of variants on potato yield ( $t\ ha^{-1}$ ) in 2019



**Figure 3** The effect of variants on potato yield ( $t\ ha^{-1}$ ) in 2020



**Figure 4** The effect of variants on potato yield ( $t\ ha^{-1}$ ) in 2021



**Figure 5** The effect of variants on starch content (%) on average years 2019 - 2021

The manufacturers of herbicides, who recommend mixed applications of active ingredients, try to provide an efficacy on broader weed range. Conclusions of Kalkhoran et al. (2021), who refers that in such cases it is purposeful to measure chlorophyll fluorescence parameters that could show physiological stresses caused by herbicides, seem to be

inspirational. It is an inspirational idea for the future also in the framework of herbicides we tested.

In addition, qualitative parameters were studied – tuber size distribution and starch content. No significant differences were found, for illustration we present Figure 5 showing starch content not influenced by variants.

## CONCLUSIONS

All evaluated variants of herbicide active ingredients and their combinations provided a good weed control efficacy.

An application of metribuzin + prosulfocarb combination early after emergence had a negative impact on potato growth, which resulted in low potato yield across the years insignificant with non-treated control, in contrast with all other variants.

The highest potato yield and corresponding high weed control efficacy was determined in the variants with metabromurone combinations (Var. 9 metabromuron + prosulfocarb and Var. 10 metabromuron + aclonifen).

The evaluated variants did not indicate an effect on studied quality indices (tuber size distribution after harvest and starch content).

## ACKNOWLEDGEMENTS

The contribution was compiled under financial support of the Ministry of Agriculture of the Czech Republic in the project MZE – RO1621.

## REFERENCES

- Abdallah, I. S., Atia, M. A., Nasrallah, A. K., El-Beltagi, H. S., Kabil, F. F., El-Mogy, M. M., Abdeldaym, E. A. (2021). Effect of new pre-emergence herbicides on quality and yield of potato and its associated weeds. *Sustainability*, 13, 9796.
- Bergmann, H. (2016). Proman – a strong base for flexible herbicide strategies in potato production. *Julius-Kühn-Archiv*. 10.5073/jka.2016.452.045.
- Čepl, J., Kasal, P. (2010). Weed Mapping—A Way to Reduce Herbicide Doses. *Potato Research* 53,359-371.
- El-Ganainy, S., Abbas, A., Elhefny, D., Abdallah, I. (2022). Efficacy of the New Herbicide Clomazone Against Weeds in Potato (*Solanum tuberosum* L.), Its Effect On Quality and Its Residues in Tubers and Soil. *Gesunde Pflanzen* 10.
- Farm to Fork Strategy (2020). COM(2020) 381, on line from: <https://eur-lex.europa.eu/legal-content/EN/TXT/?uri=CELEX%3A52020DC0381>
- Felix, J., Boydston, R., Burke, I. (2011). Potato Response to Simulated Glyphosate Drift. *Weed Technology* 25, 637-644.
- Gitsopoulos, T., Damalas, C., Georgoulas, I. (2014). Herbicide Mixtures for Control of Water Smartweed (*Polygonum amphibium*) and Wild Buckwheat (*Polygonum convolvulus*). *Potato. Weed Technology* 28, 401-407.

- Ilić, O., Nikolić, L., Ilin, Ž., Mišković, A., Vujasinović, V., Kukić, B.r. (2016). Effect of cultural practices on weeds community in function of potato yield. *Acta scientiarum Polonorum. Hortorum cultus = Ogródnictwo* 15, 31-43
- Kalkhoran, E., Alebrahim, M., Abad, H., Streibig, J., Ghavidel, A., Tseng, T.M. (2021). The Joint Action of Some Broadleaf Herbicides on Potato (*Solanum tuberosum* L.) Weeds and Photosynthetic Performance of Potato. *Agriculture* 11, 1103.
- Kasal, P. (2021) Regulation of weeds in the cultivation of potatoes in protective zones of water resources, *Agromanual* 3, 38-39. (*czech*).
- Klara, B., Zvonimir, O. (2004). Control of weeds in potato using a mixture of flufenacet and metribuzin. *Herbologia* 5, 65–73.
- Luz, J., Fonseca, L., Duarte, I. (2018). Selectivity of pre-emergence herbicides in potato cv. Innovator. *Horticultura Brasileira* 36, 223-228
- Murray, M. (1994) Early broadleaf weed control in potato (*Solanum tuberosum*) with herbicides. *Weed technology* 8, 165-167.
- Ramesh, K., Kumar, S.V., Upadhyay, P.K., Chauhan, B.S. (2021). Revisiting the concept of the critical period of weed control. *Journal of agricultural science* 159, 636-642
- Zarzecka, K., Gugala, M., Sikorska, A., Grzywacz, K., Niewęglowski, M. (2020). Marketable Yield of Potato and Its Quantitative Parameters after Application of Herbicides and Biostimulants. *Agriculture* 10, 49.

---

---



## REDUCING DROUGHT RISKS IN WETLANDS: ANALYSIS OF CAUSALITY RELATIONS BETWEEN REGULATING MEASURES USING DEMATEL

Zorica SRĐEVIĆ<sup>1\*</sup>, Bojan SRĐEVIĆ<sup>1</sup>, Senka ŽDERO<sup>1</sup>, Milica ILIĆ<sup>1</sup>,  
Laslo GALAMBOŠ<sup>2</sup>, Tanja BOŠNJAK<sup>2</sup>

\*E-mail of corresponding author: zorica.srdjevic@polj.uns.ac.rs

<sup>1</sup>University of Novi Sad, Faculty of Agriculture, Trg D. Obradovica 8, 21000 Novi Sad, Serbia

<sup>2</sup>Institute for Nature Conservation of Vojvodina Province, Radnicka 22a, 21000 Novi Sad, Serbia

### ABSTRACT

*Decision-making in the presence of multiple criteria is commonly supported by the techniques and tools belonging to soft optimization. In applications of typical methods such as Simple Additive or Simple Product Weighting, SMART, TOPSIS, PROMETHEE, AHP, VIKOR, ELECTRE, and BWM, decision elements – criteria, sub-criteria (if any) and alternatives – are commonly considered independent. In most cases, this is not true, or at least not completely true. If the decision problem is considered as a system, and its decision elements as factors, then the DEMATEL (Decision Making Trial and Evaluation Laboratory) method can be used to detect and appropriately map so-called cause-effect relationships between factors. In addition, this method may indicate the mutual importance of decision elements, especially criteria as more important influential factors in the system (decision problem). This way, DEMATEL may help decision makers to better understand strategic features of the 'system', and help them to proceed with tactical applications of multicriteria methods and solve decision problems in rather a standard manner. In this paper the results of DEMATEL will be presented, as it has been used for assessing causality and importance relations between a selected set of regulation measures important in managing the state of the wetland in a floodplain area of the Danube River near Novi Sad in Serbia (Province of Vojvodina).*

**Keywords:** wetland, regulation measures, DEMATEL, causality relations

### INTRODUCTION

Wetlands exist all over the world, in areas where water and land are contiguous. By definition, wetlands are 'areas that are inundated by surface or groundwater with a frequency

sufficient to support a prevalence of vegetative or aquatic life that requires saturated or seasonally saturated soil conditions for growth or reproduction’ (<https://www.eea.europa.eu/help/glossary/eea-glossary/wetland>). Defining characteristic of the wetland is the quantity of water present and the timing of its presence, and they have ‘high inter- and intra-annual ecohydrological variations that are driven to a great extent by climate variability and anthropogenic influences’ (Gxokwe et al., 2022). As such, wetlands are highly sensitive to climate change, especially to drought since changing hydrology and rising temperatures alter the biogeochemistry and functions of a wetland, can cause decomposition and release nutrients to surface water, shifting wetland from a carbon sink to a carbon source, cause displacement or death of aquatic species, impact the human activities (agriculture, recreation, culture), etc.

To reduce the different types of risks to wetlands (including drought), different measures can be applied; some of them are general (reduction of pollution from agriculture, floodplain restoration, flood risk reduction on agricultural land), and some are specific for certain location (establishment of buffer zones, restoration of longitudinal connectivity, prevention or control of the adverse impacts of recreation). Usually, more than one measure is applied, and the objective of this paper is the analysis of causality relations between regulating measures aimed at reducing drought risk in Special Nature Reserve Koviljsko-petrovaradinski rit (KPR), a floodplain area of the Danube River near the City of Novi Sad, Serbia.

In this paper, the causality of seven regulating measures (floodplain restoration, habitat improvement, prevention or control of the adverse impacts of invasive species, policy changes, environmental education & awareness campaign, streamlining the decision-making process, application of nature-based solutions) is analyzed using the DEMATEL (Decision Making Trial and Evaluation Laboratory) method for several reasons. Most important are that it is proven to be a reliable and efficient tool in detecting and mapping cause-effect relationships between factors and also for indicating the mutual importance of decision elements (here regulating measures) (Sheng-Li et al., 2018; Lakicevic and Srdjevic, 2022). Six experts assessed the relationship between 7 measures. Their individual beliefs resulting from the DEMATEL application are aggregated into group identification of which measures can be treated as causes and which as effects in managing the state of the KPR wetland.

## MATERIALS AND METHODS

### *Special Nature Reserve Koviljsko-petrovaradinski rit, Serbia*

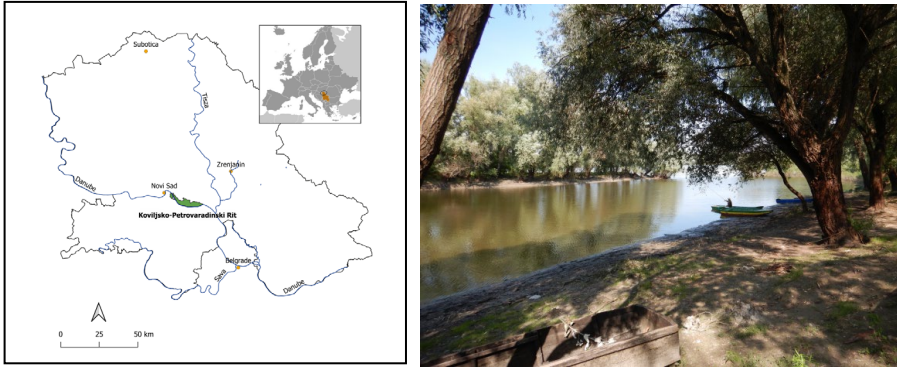
Special nature reserve Koviljsko-petrovaradinski Rit (Figure 1) is located in the inundation of the Danube river and represents the unique mosaic of aquatic, wetland, and terrestrial ecosystems.

The area of the KPR is divided into forest areas (69%), meadows and pastures occupy 15% of the total area of KPR, and water areas occupy 8% (KPR MP, 2012). Protection of the KPR is carried out on both the national (established three-stage protection) and international levels. By Articles 17 and 29 of the Law on Nature Protection (2016) and due to its rarities and specific characteristics of wetlands and characteristic representatives of flora and fauna, it is classified in the I protection category as a Special Nature Reserve as well.

The international significance of the Reserve is attained by IBA, IPA, ICPDR statuses, Danube Network Protected Areas, Dartmoor National Park Authority, and EMERALD status.



At the same time, KPR is of high economic value and has significant tourism potential, cultural and agricultural potential.



**Figure 1** Location of the KPR (Srdjevic et al., 2021)

Several past droughts impacted KPR by worsening the hydrologic regime of the river, lowering the water level in wetlands, and minimizing the provision of ecosystem services. Local and regional interests in reducing drought impacts on KPR were exposed by stakeholders from different sectors: farmers, foresters, ecologists, authorities, and NGOs through several workshops organized within the project *Improving water quality in the Danube river and its tributaries by integrative floodplain management based on ecosystem services* (IDES) ([www.interreg-danube.eu/ides](http://www.interreg-danube.eu/ides)). It was recognized that reducing negative impacts can be partially achieved by better organizational activities and the provision of more financial resources, but also with the implementation of nature-based solutions.

## DEMATEL

DEMATEL is a mathematically simple method that is implemented in five clearly defined steps. These steps will be briefly described below according to (Srđević and Srđević, 2022).

In the method description, the group application context of the method with  $K$  participants is implied. When  $K=1$  the method version is individual, thus there is no averaging foreseen in the first step.

**Step 1:** A set of factors  $F_1, F_2, \dots, F_n$  has to be formed. These are the components of a complex system that could be more or less connected to each other, or not at all. After identifying the factors, a causality scale is adopted for pair-wise comparison of the factors. The most commonly used scale is 0 - no influence; 1 – small influence; 2 – medium influence; 3 – high influence. In some cases (as in this paper), the 4 is added - extremely high influence. Factors and their direct relations are usually visualized by using a directed graph with associated scale values.

**Step 2:** Each group member  $k$  ( $k=1, \dots, K$ ) forms its matrix  $D_k$  of direct relations between factors  $F_1, F_2, \dots, F_n$  using the scale from Step 1. Using individual matrices  $D_k$ , the averaged (group) direct influence matrix  $D = [d_{ij}]$  is calculated using relation (1).

$$d_{ij} = \frac{1}{K} \sum_{k=1}^K d_{ij}^k \quad (1)$$

The notation in creating the matrix  $D$  is:

$K$  – number of group members

$n$  – number of factors

$d_{ij}$  – degree of influence of factor  $F_i$  on factor  $F_j$  ( $i$  corresponds to the matrix row and  $j$  to the column of the matrix)

$d_{ij}^k$  – degree of influence of factor  $F_i$  on factor  $F_j$  for the  $k^{\text{th}}$  member of the group

$d^k$  –  $n \times n$  non-negative matrix for the  $k^{\text{th}}$  member of the group.

Neither individual nor group direct relational matrices are symmetric, and there are zeros on the main diagonal of each matrix.

**Step 3:** The normalization of the direct relational matrix ( $D$ ) consists in mapping the values  $d_{ij}$  to the interval  $[0,1]$  using relations:

$$N = D/s \quad s = \max(\max_{1 < i < n} \sum_{j=1}^n d_{ij}, \max_{1 < j < n} \sum_{i=1}^n d_{ij}) \quad (2)$$

**Step 4:** In this step, the total influence matrix  $T$  is calculated as:

$$T = D \cdot (I - D)^{-1} \quad (3)$$

Matrix  $I$  is the identity matrix, and the superscript  $(-1)$  denotes the inversion of the matrix  $(I - D)$ .

Further, in the matrix  $T$ , sums of elements by rows and columns are calculated and vectors  $R$  and  $C$  are formed, respectively. These vectors are used to calculate the vectors  $R + C$  and  $R - C$ , which will show the cause-and-effect relationships of the factors on the diagram. If the values in the vectors are less than the threshold value, the values in the matrix  $T$  are reset to zero.

The corresponding notation is as follows,

$R$  – a vector with sums rows in matrix  $T$ :

$$R = [r_i]_{n \times 1}, r_i = \sum_{j=1}^n t_{ij} \quad (4)$$

$C$  – a vector with sums of columns in matrix  $T$ :

$$C = [c_j]_{1 \times n}, c_j = \sum_{i=1}^n t_{ij} \quad (5)$$

A threshold value is most often determined as the mean value of vectors  $R$  and  $C$ . On the graph in the next step, the threshold value represents the central vertical line that separates quadrants I and IV from II and III.

The values in the vectors  $R + C = [r_i + c_j]^T$  and  $R - C = [r_i - c_j]^T$  indicate the significance and net effect of the  $F_i$  factor as follows:  $(r_i + c_j)$  represents the significance of the  $F_i$  factor, and  $(r_i - c_j)$  represents the net effect of the same factor.

**Step 5:** In the last step, the threshold value is calculated usually as the mean value of all elements in the matrix  $T$ . Using this value, a graph with coordinate axes  $(r+c, r-c)$  is drawn to identify important and less important factors in the system.

## RESULTS AND DISCUSSION

As part of Step 1 and Step 2 of the DEMATEL methodology, six experts participated in the process of identifying the causality relationship of seven regulating measures important for managing the state of the KPR wetland and reducing drought risk:

- M1 - floodplain restoration
- M2 - habitat improvement
- M3 - prevention or control of the adverse impacts of invasive species
- M4 - policy changes
- M5- environmental education & awareness campaign
- M6 - streamlining the decision-making process and
- M7 - application of nature-based solutions.

Experts were asked to fill the causal relationship matrix as shown in Figure 2.

Measures	M1	M2	M3	M4	M5	M6	M7
M1	0						
M2		0					
M3			0				
M4				0			
M5					0		
M6						0	
M7							0

**Figure 2** Causal relationship matrix

using the comparison scale as presented in Table 1. Measures are compared in pairs by placing the number from the table in the appropriate cell of the matrix. For example, if the expert believes that M1 does not influence M4, the number in the highlighted cell will be 0.

**Table 1** Comparison scale of the influence of one measure on the other

Description	Numerical
No influence	0
Small influence	1
Medium influence	2
Significant influence	3
Very significant influence	4

Figure 3 presents the results of the causal relationship analysis made by expert no. 5.

Measures	M1	M2	M3	M4	M5	M6	M7
M1	0	4	2	2	2	1	3
M2	3	0	3	2	2	1	2
M3	1	4	0	2	2	1	1
M4	3	3	3	0	3	3	3
M5	4	4	4	1	0	3	3
M6	3	3	3	2	4	0	3
M7	4	4	3	2	2	2	0

**Figure 3** Causal relationship matrix filled by expert no. 5

Using the numbers from the matrix presented in Figure 3 and equations (1)-(5) from Steps 3 and 4, the resulting identification of causes and effects by expert no. 5 is given in Figure 4.

Ri+Ci	Ri-Ci	Cause/effect	Measures
8.46246	<b>-0.95990</b>	<b>Effect (-)</b>	<b>M1</b>
9.23843	<b>-2.27103</b>	<b>Effect (-)</b>	<b>M2</b>
7.75850	<b>-1.73941</b>	<b>Effect (-)</b>	<b>M3</b>
7.89377	1.67700	Cause (+)	<b>M4</b>
8.77111	0.95182	Cause (+)	<b>M5</b>
7.69308	1.88462	Cause (+)	<b>M6</b>
8.36835	0.45691	Cause (+)	<b>M7</b>

**Figure 4** Identification of causes and effects by expert no. 5

Results of the calculation using the 1-4 DEMATEL steps for all six experts are given in Table 2. Initial direct relation matrices created by experts are used to calculate the average value at each cell and by applying the DEMATE procedure to finally identify which measures are causes and effects as a group decision (highlighted column in Table 2).

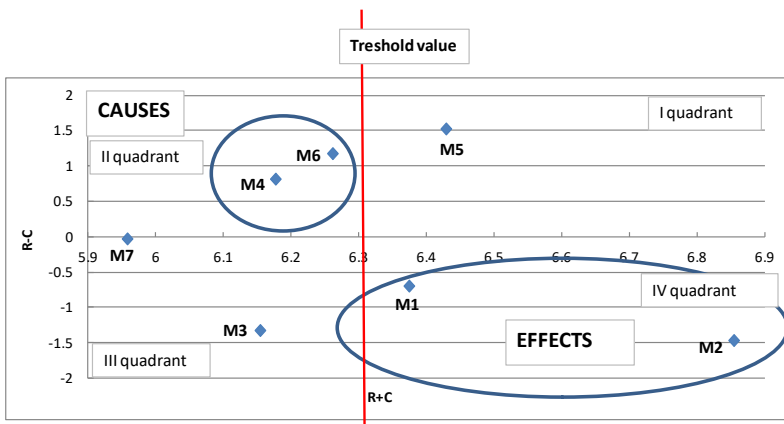
After mapping the group results as final Step 5 (Figure 5), it is easy to visually distinguish the causes (M4 – policy changes and M6 – streamlining the decision-making process) and the effects (M1 – floodplain restoration and M2 – habitat improvement). According to (Sheng-Li et al., 2018), elements mapped in quadrant III are independent factors and can be excluded when analyzing regulating measures in managing the state of the KPR; these measures in this case are M3 – prevention or control of the adverse impacts of invasive species, and M7 – application of nature-based solutions). Measure M5 – environmental education & awareness campaign (mapped in quadrant I) belongs to the basic factors.

**Table 2** Identified cause/effects by 6 experts and by group

Measures	Expert 1	Expert 2	Expert 3	Expert 4	Expert 5	Expert 6	Group
<b>M1</b>	Cause (+)	<b>Effect (-)</b>	<b>Effect (-)</b>	<b>Effect (-)</b>	<b>Effect (-)</b>	<b>Effect (-)</b>	<b>Effect (-)</b>
<b>M2</b>	Cause (+)	<b>Effect (-)</b>	<b>Effect (-)</b>	<b>Effect (-)</b>	<b>Effect (-)</b>	<b>Effect (-)</b>	<b>Effect (-)</b>
<b>M3</b>	Cause (+)	<b>Effect (-)</b>	<b>Effect (-)</b>	<b>Effect (-)</b>	<b>Effect (-)</b>	<b>Effect (-)</b>	<b>Effect (-)</b>
<b>M4</b>	Cause (+)	<b>Effect (-)</b>	<b>Effect (-)</b>	Cause (+)	Cause (+)	Cause (+)	Cause (+)
<b>M5</b>	<b>Effect (-)</b>	Cause (+)	Cause (+)	Cause (+)	Cause (+)	Cause (+)	Cause (+)
<b>M6</b>	<b>Effect (-)</b>	Cause (+)	Cause (+)	Cause (+)	Cause (+)	Cause (+)	Cause (+)
<b>M7</b>	Cause (+)	Cause (+)	Cause (+)	<b>Effect (-)</b>	Cause (+)	<b>Effect (-)</b>	<b>Effect (-)</b>

Analysis of causes and effects can be performed at individual and group levels, and in different directions. One possibility is to assess the initial coherence of individual direct influence matrices with the corresponding initial group matrix, or to compare the final results presented in Table 2 and Fig. 5; in later case, all experts, except expert 1, agree that measures M1, M2, and M3 belong to effects cluster, while measures M5 and M6 belong to the causes cluster.

The other possibility is to analyze the importance of measures and apply additional instruments of determining their mutual preference relations, particularly important if multi-criteria analysis will follow. The importance of different measures for the group can also be determined from Figure 5, i.e. from the values of  $(R_i+C_i)$ . The higher value of  $R_i+C_i$  means higher importance of the measure; in this case, the order of importance is the following: M2 > M5 > M1 > M6 > M4 > M3 > M7 (habitat improvement > environmental education & awareness campaign > floodplain restoration > streamlining the decision-making process > policy changes > prevention or control of the adverse impacts of invasive species > application of nature-based solutions).



**Figure 5** A diagram of causal relations among measures

## CONCLUSIONS

Most of the multicriteria methods assume that decision elements are independent. In real-life problems, usually, this is not the case and different methods can be used to assess and analyze the causal relationship among factors and identify possible synergies or trade-offs.

If the decision making-problem is considered as a 'system', and criteria as its 'factors', the final selection of alternative solutions is strongly dependent on preference relations among criteria, but even more on possible direct or indirect causalities (cause-effect relations) among them. Assumed independency should be checked before the comparison of alternatives across the criteria set is performed by one or more decision-makers because the final result commonly bears preference information among alternatives. Further implications are obvious in either selection or allocation decision-making processes.

This paper aimed to apply the DEMATEL method in a group setting to identify causes and effects among a selected set of regulation measures important in managing the state of the wetland in a floodplain area of the Danube River near Novi Sad in Serbia. Experts' opinion is that streamlining the decision-making process and policy changes are causes of perceived risks and the measures that affect others, so decision and policy-makers should, when preparing management plans, pay special attention to those two measures. On the other hand, habitat improvement and floodplain restoration represent the effects of perceived benefits of improved management in the KPR wetland.

Interestingly, the application of nature-based solutions is ranked as the least important measure although current research worldwide recommends the use of it due to its high potential to enable numerous benefits to the environment and society.

## ACKNOWLEDGEMENT

This research has been partially supported by the Ministry of Education, Science and Technological Development of Serbia (Grant #451-03-9/2022-14/200117).

## REFERENCES

- Gxokwe, S., Dube, T., Mazvimavi, D., Grenfell, M. (2022). Using cloud computing techniques to monitor long-term variations in ecohydrological dynamics of small seasonally-flooded wetlands in semi-arid South Africa. *Journal of Hydrology*, 612, article 128080.
- KPR MP (2012). Koviljsko-petrovaradinski rit Management plan 2012-2021. Vojvodina Šume. / In Serbian
- Lakicevic, M, Srdjevic, B. (2022). An Approach to Developing the Multicriteria Optimal Forest Management Plan: The "Fruska Gora" National Park Case Study. *Land*, 11(10):1671. <https://doi.org/10.3390/land11101671>
- Sheng-Li, S., Xiao-Yue, Y., Hu-Chen, L., & Zhang, P. (2018). DEMATEL Technique: A Systematic Review of the State-of-the-Art Literature on Methodologies and Applications. *Mathematical Problems in Engineering*.
- Srđević, Z., Srđević, B. (2022). DEMATEL i AHP u analizi međuzavisnosti i preferenci kriterijuma u problemima odlučivanja u vodoprivredi. (Use of DEMATEL AND AHP in analysing causality and preferences of criteria in water management related decision-making) *Vodoprivreda*, 0350-0519, Vol. 54, No. 315-316 p. 1-9. / In Serbian

Srđević, Z., Stammel, B., Ionescu, C., Galamboš, L., Srđević, B., Grabić, J., Ždero, S., Ilić, M., Benka, P., Antić, A. (2021). Stejkholderi u specijalnom rezervatu prirode Koviljsko-petrovaradinski rit kod Novog Sada: ko su i kako ih uključiti u procese identifikacije i integracije ekosistemskih usluga važnih za poboljšanje kvaliteta vode Dunava?. (Stakeholders in the Koviljsko-petrovaradinski rit Special Nature Reserve near Novi Sad, Serbia: who are they and how to involve them in the processes of identification and integration of ecosystem services important for improving the Danube water quality?). *Vodoprivreda*, 0350-0519, Vol. 53, No. 309-311 p.241-248. / In Serbian

\*\*\*The Law on Nature Protection ("Official Gazette of RS", No. 36/2009, 88/2010, 91/2010 - corr., and 14/2016).

---

---





## MULTICRITERIA AND SOCIAL CHOICE METHODS IN AGRICULTURE, WATER MANAGEMENT AND FORESTRY

Bojan SRDJEVIC\*, Zorica SRDJEVIC

\*E-mail of corresponding author: bojans@polj.uns.ac.rs

University of Novi Sad, Faculty of Agriculture, Department of Water Management,  
Trg D. Obradovica 8, 21000 Novi Sad, Serbia

### ABSTRACT

*Numerous research studies worldwide have shown that weak optimization and multi-criteria analysis may help decision-makers to easily formulate, develop and judge alternative solutions and actions, perform risk analyses, and produce a wide range of unbiased soft solutions, easy to handle and evaluate before application. In solving decision problems in group contexts, it is shown that social choice theory methods can also be efficiently used to enable the voting of participants. Moreover, voting methods can be combined with multi-criteria methods (adapted for group applications) and provide comparable solutions in the search for the most appropriate. The paper presents several examples of using advanced systems analysis techniques and decision-making tools in agriculture-water-forestry-related studies in Serbia, particularly in searching for 'best solutions' in complex individual and group scenarios. A brief overview of solved problems is presented for selecting cattle food suppliers, evaluating walnut cultivars, evaluating the importance of criteria for risk assessments of Ramsar protected wet areas, prediction of water quality, and detecting causality relations and importance of criteria used in assessments of water management plans and sustainable forestry goals.*

**Keywords:** agriculture, water resources, forestry, decision-making

### INTRODUCTION

There are two principal decision-making contexts in agricultural, water resources, and forestry management: individual and group. The outcome of each one is identified decision, the best or most desired one. The decision is not necessarily optimal because of inherent conflicts among adopted evaluation criteria. What methodology of decision-making will be applied and which techniques will be used for assessment of the decision elements depend on

the determination and structure of the problem, individual and group capacity of the decision makers (professional expertise, education, attitude, availability, etc.), and implications which will follow once the decision is implemented.

Two distinct methodologies are applicable in establishing the systems approach to group decision-making. The first is to create multi-criteria decision-making (MCDM) framework which is useful in handling structured problems. The other is to rely on social choice theory (SCT) with its voting systems when available information is minimal, unconfident, or predominantly qualitative. MCDM and SCT methods perform differently concerning issues such as justice, fairness, or transparency to manipulation at various stages of implementation. Most of the reported research shows that the use of methods from these two classes may easily declare different winners. This is the main reason why a comparison of different methods applied to the same problem is useful to both scientists and practitioners since the detailed analysis of the results helps to find the most appropriate solution methodology in similar cases. The role of the systems approach appears to be essential.

In this paper, we present several examples of separate and combined use of MCDM and SCT methods in different group decision-making contexts in contemporary agriculture, and water and forestry management. A brief description is given of seven decision problems related to selecting cattle food suppliers, evaluating walnut cultivars, assessing criteria for managing risks associated with wetland (Ramsar) areas, prediction of water quality, and most recently validating causal and importance relations in assessments of sustainable forestry goals by DEMATEL (Fontela, 1974; Gabus, 1973) and AHP (Saaty, 1980) methodologies. Example problems and solutions are taken from published peer-reviewed papers by members of the Group for Systems Analysis and Decision-making in the Department of Water Management, Faculty of Agriculture, University of Novi Sad, Serbia. Problem statements and main results are presented in the next section and are mainly replicated from the abstracts and conclusions of refereed papers.

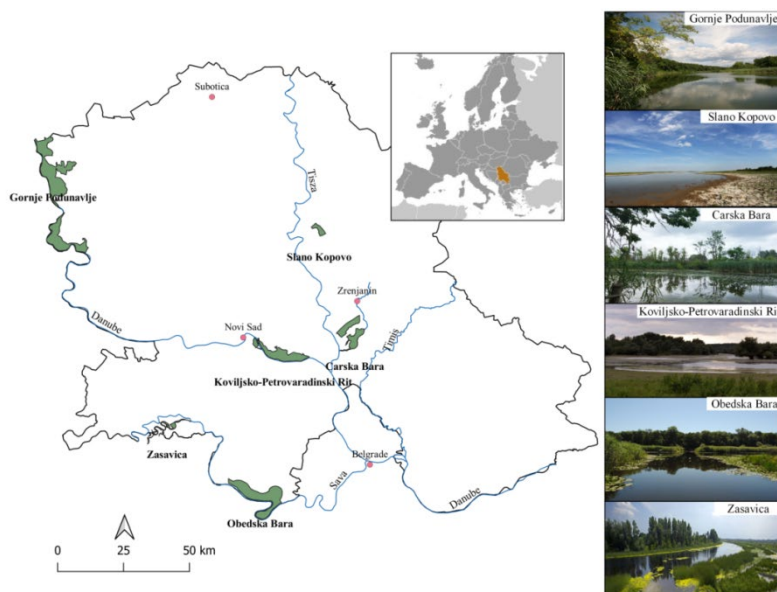
Limited space prevents presenting results of several other studies related to evaluating plant species for riverbanks landscaping in urban zones, assessment of irrigation and drainage methods, evaluating groundwater ponds as suppliers to urban water distribution systems, ranking long-term water management plans, evaluating land suitability for irrigation and irrigation canal lining variants, etc.

## MATERIALS AND METHODS

The following examples illustrate research outcomes of MCDM and SCT methods application in solving decision-making problems in single-participant and group decision-making environments. Related references at the end of the paper contain a description of methodological approaches used in solving problems with a detailed presentation of the results obtained.

### *Example #1: Evaluating criteria for risk assessments of Ramsars (Srđević and Ilić, 2020)*

Ten protected nature reserves (wetlands) in Serbia are recognized as Ramsar sites by the Ramsar convention; eight of them are located in Vojvodina Province, and six were selected for assessment, Fig.1 and 2.



**Figure 1** Ramsar sites in Vojvodina Province, Serbia (Srđević and Ilić, 2020)

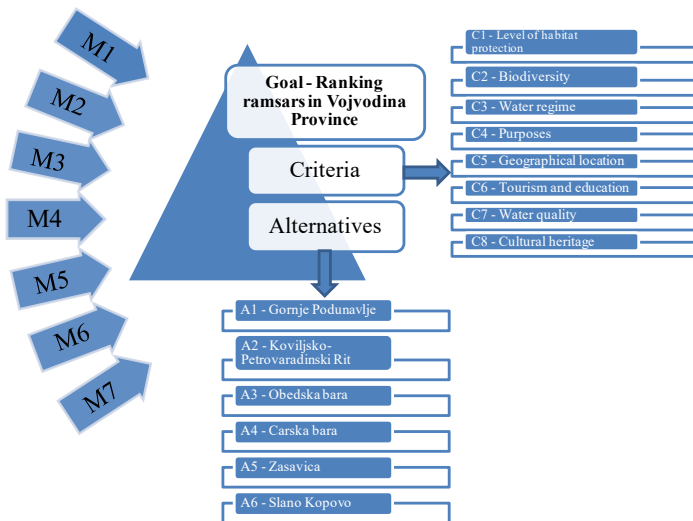
A group decision-making model is used for evaluating risk-related and other important criteria usable in ranking Ramsar sites by importance, for instance by needs for management improvements under climate change, requiring additional investment, etc. The rationale was that criteria should reflect Ramsar's ecological, economic, touristic, and cultural aspects, as well as their capability in provisioning ecosystem services. Seven professionals are invited to participate in a scientific experiment. They validated eight criteria by combining the multicriteria method Analytic hierarchy process and the Borda Count method from social choice theory. The model is implemented by sending electronic questionnaires to participants, computing weights of criteria from received individual judgments, and aggregating individual sets of weights into group values. Consistency parameters, conformity indicators, and Spearman's correlation coefficients of ranks are computed to check the quality of the decision-making process and to enable mappings and visualization. The proposed modeling approach belongs to systems analysis and is applicable in the water resources and agriculture sector.

***Example #2: Group model for evaluating the importance of Ramsar sites in the Vojvodina Province of Serbia (Srđević et al., 2021)***

Following the recommendations given in (Ex.#1), a holistic group decision-making approach is developed in this study for evaluating the global importance of protected nature reserves (all recognized as Ramsars) in the Vojvodina Province of Serbia. The group model is based on AHP and preferences among Ramsars are determined regarding plans for their management. Focus in the assessment has been given to risk protection, preservation, and exploitation of wetlands. Once weights of eight criteria identified in Ex. #1 are determined individually by seven members of the group, each member performed pairwise comparisons of six Ramsars concerning each criterion. That is, each member created 8 matrices of size 6

(for each criterion one matrix related to Ramsar). Then, local weights of Ramsars regarding each criterion are computed, and finally, AHP synthesis is performed. The final result for each member was a set of global weights of Ramsars versus the goal stated as ‘ranking Ramsars by importance’, Fig 2. Top-ranked Gornje Podunavlje received significant weight (0.279), compared to second and third-ranked Koviljsko-Petrovaradinski Rit and Obedska Bara with weights of 0.191 and 0.175, respectively. The last ranked Slano Kopovo received the lowest weight of only 0.081.

When the results of AHP have been presented to the members of a group, they all agreed that this is what they expected to happen. In a way, they approved the methodology and agreed that obtained results coincided with their perception and understanding of Ramsars’ importance from a risk protection perspective.



**Figure 2** Hierarchy of the Ramsars ranking s problem (Srđević et al., 2021)

The AHP results (weights) are then interpreted in the SCT context. The Borda Count preferential voting method is applied using the AHP results and obtained criteria ranking by two methods was equivalent for the first five positions (out of 6).

**Example #3: Water quality prediction based on the Naïve Bayes algorithm (Ilić et al., 2022)**

Water quality prediction is an important issue for efficient water management. Very often some parameters are missing and/or difficult to measure. Besides, sampling requires a lot of time and is expensive. Because some parameters can change easily and quickly, the consequences that may occur due to incorrect predictions can be enormous. Referring to many research studies in the fast-changing world with increased water demand, water pollution, environmental problems, and related data, information on water quality and suitability for any purpose needs to be promptly available and reliable.

Because traditional approaches often fail in the attempt to predict water quality classes, in this study it is claimed that new approaches may offer an opportunity to handle a large amount of missing data and help to predict water quality in real-time more accurately. The prediction model is developed based on the application of the Naïve Bayes (NB), a widely used machine-learning method. The NB classifier is developed as a conducive predictor, facilitated to enable obtaining the final decision based on a probability distribution, i.e. on known uncertainty. In the NB classifier, the parameters are conditionally independent, and it is easy to manipulate the data (add, delete, change) within the network. For network construction and manipulation, the software Netica has been proven to be suitable. The simplicity of the NB method and the relatively low level of data pre-processing required by both NB and Netica sets this approach apart from other known machine-learning methods that also provide satisfactory results.

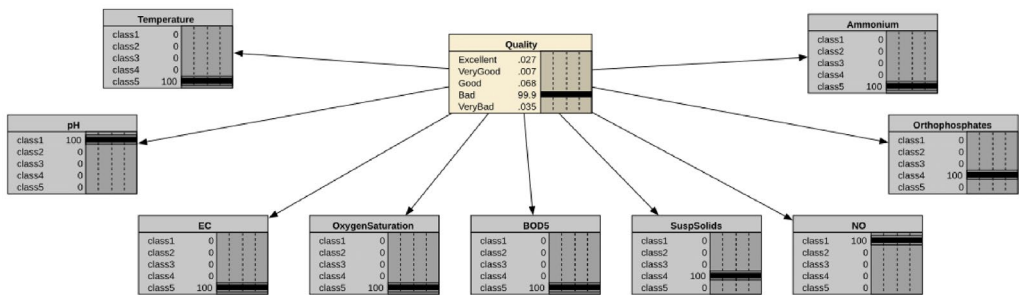


Figure 3 Bayesian network for water quality prediction (Ilić et al., 2022)

The following nine parameters related to water quality are used as the principal data set for establishing the NB model: temperature, pH value, electrical conductivity, oxygen saturation, biological oxygen demand, suspended solids, nitrogen oxides, orthophosphates, and ammonium. The Netica is used to create and test the model. For model verification, the data set for seven years is used from five locations in Vojvodina Province, Serbia, while 48 samples are used to train the model. Once trained, the model correctly predicted the class of water sample in 64 out of 68 cases, including cases with missing data. One of the conclusions of this study was that the developed approach is efficient and low-time-consuming and that the Naive Bayes model is a trustful tool in the transition from traditional to digital water management.

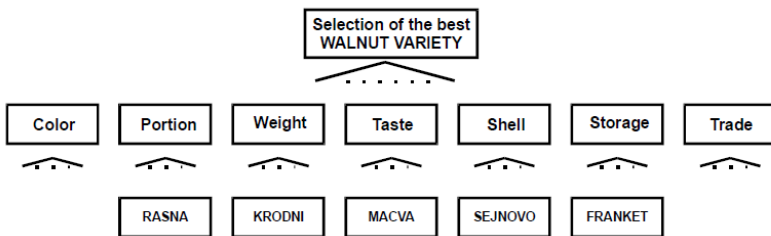
**Example #4: Objective Evaluation of Walnut Cultivars by the Analytic Hierarchy Process (Srdjevic et al., 2009)**

The walnut cultivars selection, supported by computerized multi-criteria decision-making tools, has been initiated in Serbia 35 years ago. Different case studies proved that the AHP method can integrate biological and technical aspects of the selection process and link the expertise and standardization in fruit selection in general. In real-life AHP applications in individual and group scenarios, several walnut experts participated in computer-based decision-making sessions aimed at assessing the quality of five national and foreign walnut cultivars and candidates to be acclaimed as official selections. Involved experts commented

that sessions were user-friendly and that derived weights, as global AHP outcomes indicating the walnut nuts' quality, are of trustful reliability.

Moderators of decision-making sessions suggested in a-posterior analysis that experts' opinions could be mostly based on personal feelings about the quality of walnut cultivars, especially because they might have been involved in some selection procedures. To develop a more objective approach, the eigenvector method (EV), which has been used in many AHP studies for deriving weights of decision elements, is compared to the other two well-known prioritization methods. The leading idea was to check which method produces 'objectively trustful' weights, i.e. assures the best consistency and coherency, minimizes violation criteria, and all this – regardless of experts' opinions. The methods used are logarithmic least squares (LLS) and fuzzy preference programming (FPP). Weights obtained by experts are tested on consistency and it was shown that one of the two methods in some aspects outperforms the EV method. The conclusion derived is that in real-life AHP applications an objective interpretation of results can be achieved if several prioritization methods are used on a competitive basis. Illustrative results are presented for two experts, five national and foreign cultivars, and 7 criteria: kernel's color, kernel's portion, nut's weight, the taste of the kernel, shell, storage quality, and trade value, Fig. 4.

- Criteria set
  1. Kernel's color (Color)
  2. Kernel's portion (Portion)
  3. Nut's weight (Weight)
  4. Taste of the kernel (Taste)
  5. Shell (Shell)
  6. Storage (Storage)
  7. Trade value (Trade)
- Alternative set (walnut cultivars)
  1. Rasna (Rasna)
  2. Kasni rodni (Krodni)
  3. Macva (Macva)
  4. Sejnovo (Sejnovo)
  5. Franquette (Franket)



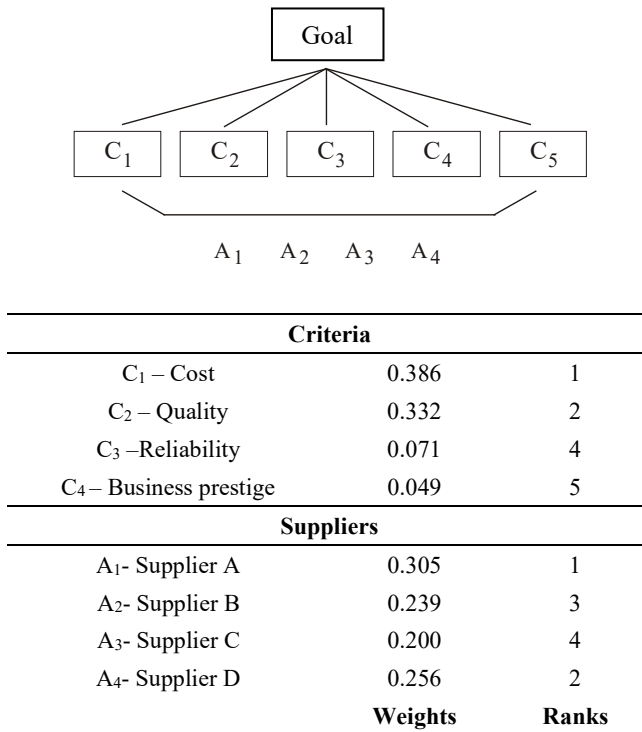
**Figure 4.** Hierarchy of the decision problem

One of the conclusions in this study was that derived weights may eventually lead to 'allocation' decisions such as (1) a given area should be cultivated by types of walnuts according to their weights (percentage share); and (2) if only few walnut types should be

planted, the remaining walnuts shares should be reallocated accordingly (proportionally) to those selected for planting; etc.

**Example #5: Selecting a cattle food supplier (Srdjevic et al., 2003)**

The paper related to this example presents the result of the AHP application in selecting a cattle food supplier. Four potential suppliers are evaluated considering five criteria: cost; food quality; supplier reliability; supplier’s prestige on the market; and payment conditions, Fig. 5 The method is recommended for use in national agricultural practice.



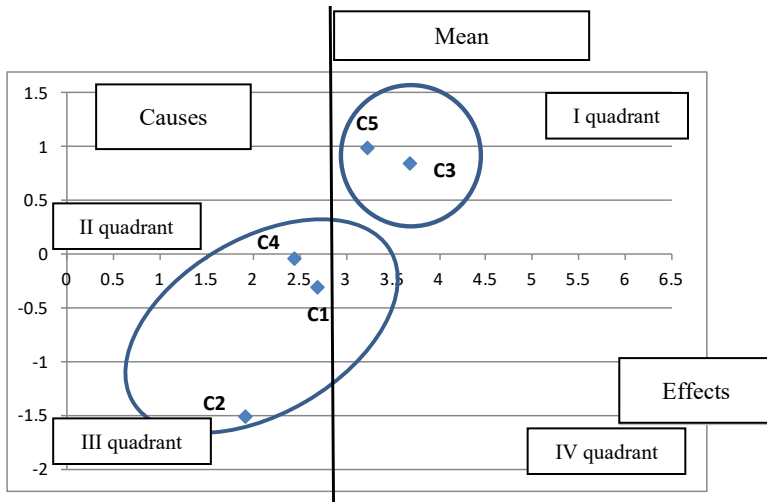
**Figure 5** AHP hierarchy of the cattle food supplier decision-making problem and main results

**Examples #6 and #7: DEMATEL and AHP in detecting causality relations and the importance of criteria for assessments of (1) water management alternatives, and (2) sustainable forestry goals (Srđević and Srđević, 2022ab)**

It is well-known that decision-making in the presence of multiple criteria is usually supported by the techniques and tools belonging to soft optimization. Methods such are AHP, VIKOR, TOPSIS, PROMETHEE, ELECTRE, or BWM, treat criteria a priori as independent; alternatives also. An attempt to identify possible criteria dependence in decision-making problems resulted in the development of the DEMATEL method which maps cause-effect

relationships between criteria. There are numerous studies dedicated to connections of this method with standard multicriteria methods.

Ex. #6 pointed to possibilities of connecting the results of DEMATEL and AHP in strategic and tactical decision-making related to the selection of irrigation technology. Figure 6 shows DEMATEL mapping of five criteria used for selecting the irrigation method.

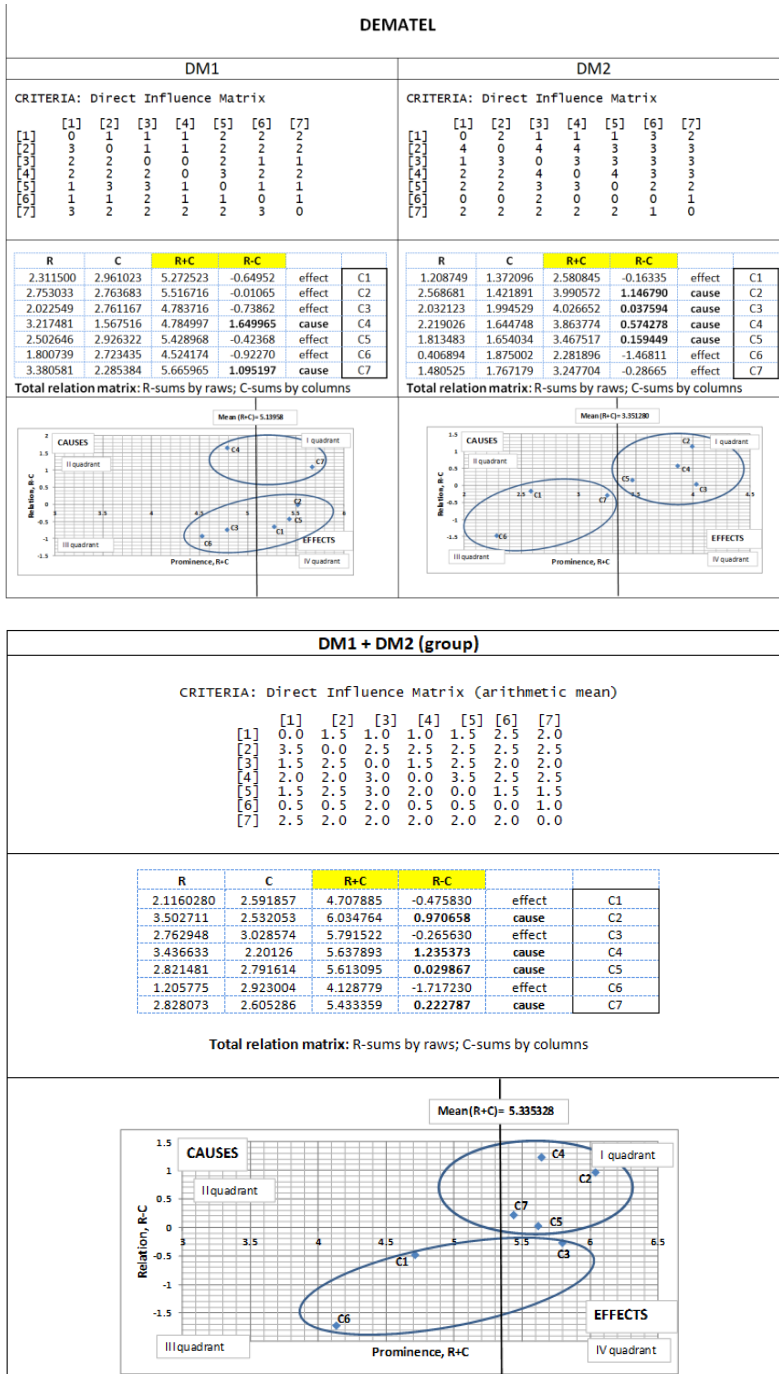


**Figure 6** DEMATEL mapping causality and importance relations between five criteria commonly used in selecting irrigation methods (Srđević and Srđević, 2022a)

In a recent study (Srdjevic and Lakicevic, 2022) presented here as Ex. #7, DEMATEL and AHP are used to analyze a selected set of criteria for evaluating sustainable forestry goals in the two-fold environment: (a) causality, and (b) importance. Creating a decision-making framework with two experts enabled the comparison of individually obtained solutions with the aggregated solutions derived from two named methodologies. The use of DEMATEL enabled strategic viewing of the causality relations among criteria and a limited indication of cardinal information (weights) about their importance. Figure 7 illustrates the input and output of this model.

Different from DEMATEL, the use of AHP is considered a control mechanism in tactical decision-making situations such as the usage of standard multi-criteria methods for solving forestry-related allocation or selection problems. AHP's role was to derive weights of criteria in a very structured environment based on assumption that criteria are independent and only their mutual importance is relevant for further decision-making. Individual solutions and aggregation schemes for creating group solutions are compared for both methodologies. Critical analysis is also given for different aspects of their combined use when treating causalities and the importance of criteria in evaluations of long-term (sustainable) forestry goals.

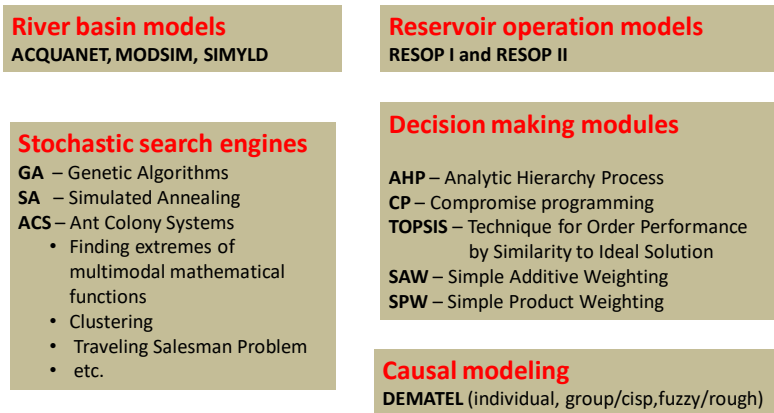




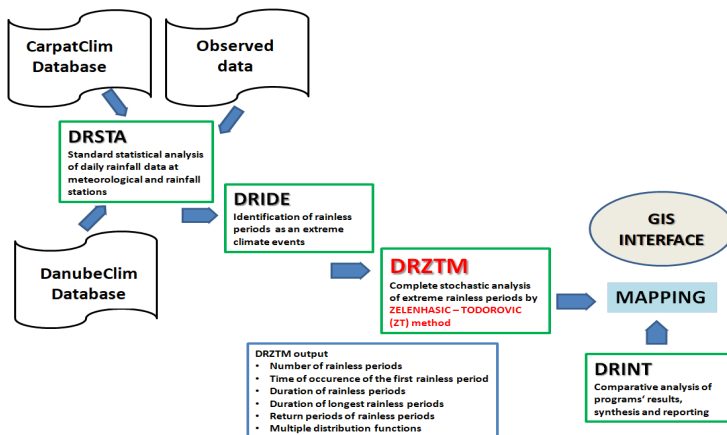
**Figure 7** Input data and results of the DEMATEL method in assessing criteria for evaluation of sustainable forestry goals (Srdjevic and Lakicevic, 2022b)

**SOFTWARE**

The group for Systems Analysis and Decision Making of the Department of Water Resources is working on the parallel use of crisp, fuzzy, hesitant, and rough versions of the AHP for solving decision-making problems in agriculture, water resources, and forestry. Individual and group scenarios are the focus of research supported by the original two modular-structured software systems, DECIDE and DROUGHTS. Their core parts are self-explained in Figures 8 and 9. DECIDE is multi-tasking software and a set of tools for supporting different approaches in decision-making environments. DROUGHTS enables comprehensive stochastic analyses of extreme meteorological droughts from an agricultural perspective. The results from these analyses are visually presented in a GIS environment.



**Figure 8** DECIDE Software for supporting decision-making processes



**Figure 9** DROUGHTS software for stochastic analysis of agricultural droughts

## CONCLUSIONS

A combination of various systems analysis techniques, decision-making methods, and GIS tools help analysts and decision makers to understand the complexity of decision problems and solve it by complementing the output of models embedded or connected with decision support systems. A rationale is to follow in the best possible way the conceptual design of processes typical for both planning and management of agricultural, water, forestry, and other sectors.

Good examples are advanced decision-support systems in water resources-related environments with sophisticated computer models for simulating the performance of interconnected multipurpose reservoirs linked to water users with different (in most cases conflict) spatial and temporal requirements. For instance, simulation or mixed simulation-optimization models produce complex and detailed information on system performance under defined governing rules and operational strategies. When used to support decision processes, generated information has to be interpreted in a systems analysis framework and at a later stage evaluated by multi-criteria methods and tools.

The systems approach can help the decision-makers to evaluate alternative scenarios of the systems' operation, analyze resource allocation, and check the fulfillment of priorities imposed. Presented examples may serve as background information for the creation of new research agenda and upgrading theoretical and practical solving methodologies for fulfilling forthcoming challenges in the subject areas tackled in this paper.

## ACKNOWLEDGEMENT

This research has been partially supported by the Ministry of Education, Science and Technological Development of Serbia (Grants #ON174003 and #451-03-9/2022-14/200117).

## REFERENCES

- d'Angelo, A., Eskandari, A., Szidarovszky, F. (1998). Social choice procedures in water resources management. *Journal of Environmental Management* 52.
- Chu, A.T.W., Kalaba, R.E., Spingarn, K. (1979). A comparison of two methods for determining the weights of belonging to fuzzy sets. *J Optim Theory Appl*, 27, 531–538. <https://doi.org/10.1007/BF00933438>
- Crawford, G., Williams, C. (1985). A note on the analysis of subjective judgment matrices. *Journal of Mathematical Psychology*, 29, 387-405.
- Fontela, E.G. (1974). *Structural Analysis of the World Problematique*. Battelle-Geneva, Research Centre.
- Gabus (1973). *Communicating with those Bearing Collective Responsibility*. Battelle-Geneva Research Centre.
- Ilić, M., Srđević, Z., Srđević, B. (2022). Water Quality Prediction Based on Naïve Bayes Algorithm. *Water Science and Technology*, IWA Publishing. Available online 10 January 2022, doi: 10.2166/wst.2022.006.
- Kou, G., Lin, C. (2014). A cosine maximization method for the priority vector derivation in AHP. *European J. Oper. Res.*, 235 (1), 225–232.

- Mikhailov, L. (2000). A fuzzy programming method for deriving priorities in the analytic hierarchy process. *J. of Oper. Res. Soc.*, 51, 341-349.
- Mikhailov, L., Singh, M.G. (1999). Comparison analysis of methods for deriving priorities in the analytic hierarchy process. *Proc. of the IEEE International Conference on Systems, Man and Cybernetics*, 1037-42.
- Saaty, T.L. (1980). *Analytic Hierarchy Process*. New York: McGraw-Hill.
- Srdjevic, B. (2005). Combining different prioritization methods in the analytic hierarchy process synthesis. *Comput. & Oper. Res.* 32 (7), 1897-1919.
- Srdjevic, B., Srdjevic, Z. (2011). Bi-criteria evolution strategy in estimating weights from the AHP ratio-scale matrices. *Appl. Math. and Comp.*, 218(4), 1254-1266. doi:10.1016/j.amc.2011.06.006
- Srdjevic, B., Srdjevic, Z. (2013). Synthesis of individual best local priority vectors in AHP-group decision making. *Appl. Soft Comput.*, 13 (4), 2045-2056. doi:10.1016/j.asoc.2012.11.010
- Srđević, B., Ilić, M. (2020). Group model for evaluating criteria to be used in risk assessments of Ramsar-protected wetland areas. *Vodoprivreda* 52(2020): 273-286. in Serbian
- Srđević, B., Srđević, Z., Ilić, M., Ždero, S. (2021). Group model for evaluating the importance of Ramsar sites in Vojvodina Province of Serbia. *Environmental Development and Sustainability* 23, 10892–10909. <https://doi.org/10.1007/s10668-020-01093-2>.
- Srdjevic, Z., Srdjevic, B., Suvocarev, K. (2009). Objective Evaluation of Walnut Cultivars by the Analytic Hierarchy Process, 7th World Congress of Computers in Agriculture and Natural Resources, June 22-24, 2009., Reno, Nevada, USA. DOI: 10.13031/2013.29096.
- Srdjevic, Z., Srdjevic, B., Zoranovic, T., Potkonjak, S. (2003). Selecting a cattle food supplier. *Agrieconomica* 32, 241-246, 2003. in Serbian
- Srđević, Z., Srđević, B. (2022a). Use of DEMATEL and AHP in analyzing causality and preferences of criteria in water management-related decision-making. Accepted for *Water Resources (Vodoprivreda) Journal*. in Serbian
- Srdjevic, B, Lakicevic, M. (2022b). Causality and importance of sustainable forestry goals: strategic and tactical assessment by combining the use of DEMATEL and AHP. *Research notes*.



## SQUALL PHENOMENA IN THE BANAT-CRIȘANA PLAIN OF ROMANIA AND THEIR IMPACT ON AGRICULTURE IN A CHANGING CLIMATE

Vlad MĂRĂZAN<sup>1\*</sup>, Alexandru ȚUCU<sup>2</sup>, Hortensia RĂDULESCU<sup>3</sup>,  
Rareș HĂLBAC-COTOARĂ-ZAMFIR<sup>1</sup>

\*E-mail of corresponding author: vladmarazan@gmail.com

<sup>1</sup> Department of Overland Communication Ways, Foundation and Cadastral Survey, Politehnica University of Timișoara, 1A Ioan Curea, 300224, Timișoara, Romania

<sup>2</sup> Faculty of Entrepreneurship, Business Engineering and Management, Politehnica University București, no.313, Spl. Independentei, Sect.6, București, RO-060042

<sup>3</sup> University of Life Sciences „King Michael I of Romania” of Timișoara, 119<sup>th</sup> Calea Aradului, 300645, Timișoara, Romania

### ABSTRACT

*The analysis of special meteorological phenomena, which through their effects may cause damage to the national economy and as such to agriculture and to the agricultural engineering, in general, is of interest in order to take preventive measures. It is known from the specialized literature that squall or squall lines are blows of wind with a relatively short duration of action. Gusts of wind are sporadic, the atmospheric pressure drops by 2 - 5 hPa, the relative humidity registers a significant increase, and the air temperature drops by 10 to 15°C. The purpose of this study is to present aspects regarding the phenomenon of storms in the Plain of Banat and Crișana in Romania, especially due to the predominantly westerly circulation. For this aspect, data related to the squall phenomenon in the period 1990-2020 was processed. Besides the climatology of squalls, this study will also focus on some important cases of squalls and their impact on agriculture in the western part of Romania. This study wants to be an argument with regard to the impact of climate change on meteorological conditions for both agriculture as well as industry in general. The frequency and intensity of squalls has increased, especially in the plain area in the western part of Romania, due to the action of the general circulation. The mean windshear speed has increased by 4.5 km h<sup>-1</sup> and the maximum windshear speed has reached 140 km h<sup>-1</sup>.*

**Keywords:** *squall lines, severe weather, agrometeorology, climate change, agricultural engineering.*

## INTRODUCTION

Severe weather phenomena represent the main danger for the economy of a region or a country. The areas which are most affected by the squalls are the transportation industry as well as agriculture. From a meteorological point of view, squalls represent a rather difficult phenomenon to effectively forecast from the point of view of the wind speed. Squall lines and gust fronts are the main objectives analysed in this paper. A thunderstorm gust front is the leading edge of the horizontal airflow resulting from the downdraft spreading at the ground, as it is the downdraft's most dramatic manifestation. The gust front is the interface between the warm, moist air in the thunderstorm environment at low altitudes and the cool, nearly saturated air of middle-level origin. Negative buoyancy propels descent of middle-level air as a substantial component of overall thunderstorm circulation (Houze Jr., 2014). This negative buoyancy results principally from evaporation of precipitation that has fallen into dry, potentially cold air that is situated, through the effect of windshear, so that it receives precipitation from above. Negative buoyancy may also result from evaporation of cloud that has formed in warm air and then mixed with dry air entrained from the near storm environment and also from the weight of condensation products accumulated in the warm, moist updraft. The descending current is deflected horizontally by the ground (Taszarek et al., 2021).

The sum of all effects sometimes produces horizontal speeds exceeding  $25 \text{ ms}^{-1}$  in the air behind the gust front. On rare occasions, the airspeed may approach twice this value and may become extremely destructive. As such, a squall is defined as being a gust of wind with wind speed exceeding  $15 \text{ ms}^{-1}$  (Barry & Blaken, 2016).

Recent attempts to correlate observational data on low-level gust front structure with data on the other aspects of thunderstorm's structure have used numerical methods and simulations. Even though numerical models of microphysical processes, as such the processes influencing development of cloud and precipitation from water vapour and models of cloud-scale dynamics have improved, thunderstorm numerical simulations are still inadequate with respect to realistic depiction of gust front details (Hangan & Kareen, 2021).

With regard to the origin of the gust front, at least two mechanisms seem to be important for generation by thunderstorms of strong horizontal winds at the ground (Moldovan, 2003):

- The downward transfer of entrained momentum from the strong environmental flow aloft, descending rain-cooled air tends to carry the horizontal momentum that it had at its original level. Thus, strong winds aloft are a significant predictive indicator of destructive potential.
- The addition of kinetic energy to the air during its descent, by virtue of density differences (Vasquez, 2021).

Dry air found in the lower middle troposphere on occasions of convective instability can be cooled by evaporation of rain or hail, often sufficiently to allow it to accelerate downward and reach the surface. Thereby the possibility arises that the severe thunderstorm and thus a squall line becomes organized not only to raise potentially warm air but also to affect a more complete and efficient overturning of a deep layer of the troposphere. That this does happen is revealed by a low wet-bulb temperature in cool squalls that spread out from beneath severe storms, as such it can be shown that air in such squalls must have descended from levels above cloud base (Trenberth, 2022). The transfer of cold water from updraft to downdraft can evidently occur only if the former leans over the latter, and there is often visible evidence of

this in the shape of the cloud base, as such forming an arch around the squall and its rearward-tilted lower surface (Rauber et al., 2017).

The cool squall has an additional importance in lifting the layers into which it advances, and thereby producing the kind of mesoscale system required to release the convective instability. Once a severe storm has been formed, it provides a mechanism for its own maintenance, and they can travel away from its source. It is envisaged that the downward that the downdraft and the updraft can compose a steadily sustained couplet of much greater efficiency than the ordinary impulsive convection. However, it has to be recognized that in consequence of the larger particle size in evaporation of water in the downdraft can virtually never be complete or as efficient as its condensation in an updraft. The conditions under which the water can be used to maintain the pair as fitting and long-lasting couplet have yet to be determined, but the wind shear must play an important and at first an unsuspected role in allowing transfer of water between the drafts (Soroceac, 2013).

The nature of the configuration of the drafts and their relative arrangement and the shape of definition of their interface has not yet been adequately explored (Șerban, 2010).

## MATERIALS AND METHODS

Within the framework of this research, the case of storms in the western area of Romania is analysed. From the point of view of the materials, data from the meteorological archive from the Timișoara airport and from the Timișoara meteorological station of the National Meteorological Administration are used. The highlighting of the significant case will be done through their separate analysis, in the sense that the most significant case of storms in the western part of Romania will be presented, accompanied by the presentation of the synoptic situation, the analysis of data from the meteorological station and the presentation of the effects produced both in the industrial sector as well as in agriculture (Nichita et al., 2014).

For the realization of this work, pressure and temperature charts are used at the 500hPa level, at 700 hPa level and at the ground level. The temperature fields from the ground from 2 meters and from aloft will also be analysed. The importance of the pressure and temperature fields are important to be able to establish a pattern regarding the intensity of the associated dangerous meteorological phenomena (Bogdan & Niculescu, 1999).

Squalls carry high waves that move with the travelling field of winds. If an unwary forecaster were to glance at a typical squall line with its 30 km width of wind speeds, he might apply rules for large storm systems and forecast waves lower than those that are actually to occur. For example, a typical method used in computing wave heights and periods involves using two parameters: wind speed and fetch. A wind speed for the area in question is found by using surface maps and predicted changes in the weather pattern, and measuring the fetch, the distance over which these winds travel in an approximately straight line. Once the wind speed and fetch for the forecast period are determined and, as such, the Bretschneider (1967) chart is used to find the wave height and wave period. These winds are assumed to blow throughout the forecast period. However, the waves in a moving squall line are much larger than are the waves observed from similar but stationary wind fields. One reason for this is the movement of the squall line. The total time history of the wave is the most important factor in wave forecasting. The wave must be watched as it moves along in order to develop an accurate wave forecast (Bojariu et al., 2021).

All data has been prepared and analysed according to the norms of the World Meteorological Organization and in order to ensure the correctness of the data, it has also been compared to the climatological assessments from the timescale 1981 – 2010 and 1991-2020 (Busuioc, 2010).

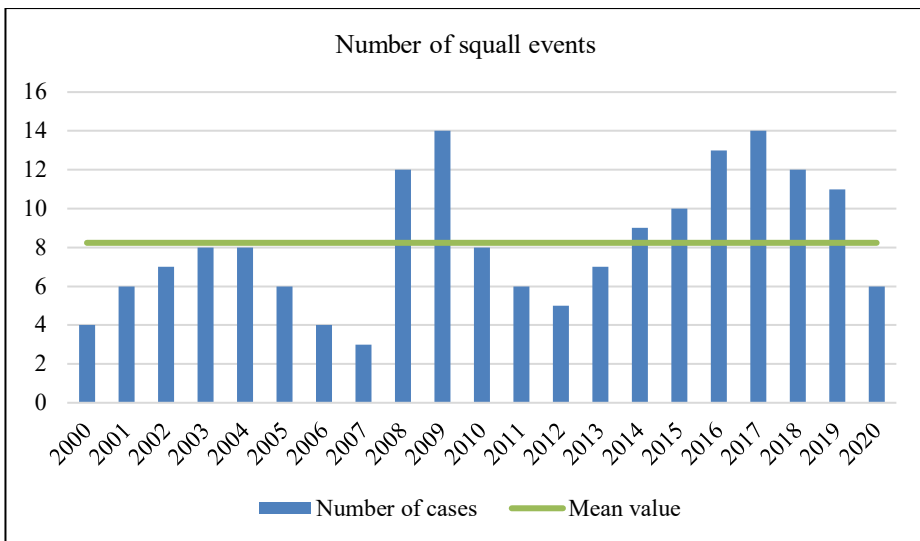
Another methodology which is to be analysed, is the dryline, which is a mesoscale feature with its own vertical circulation. As such, a dryline is a narrow, almost vertical area across which a sharp moisture gradient occurs at the earth’s surface. Even though a dryline is often not collocated with the area of maximum surface convergence, it serves as a focus for convective activity (Sandu et al., 2010; Sandu et al., 2008).

Besides using the numerical weather prediction algorithms and data from the weather stations, a strong emphasis must be made on the importance of radar equipment and satellite images. For the purpose of this paper, the case which is presented has been selected in order to focus on both synoptic-scale structures as well as local instabilities in order to emphasise the need for atmospheric surveillance equipment (Busuioc et al., 2012).

## RESULTS AND DISCUSSION

During the analysed period, an almost constant increase in the number of storm cases was noted. Among these, a distinction must be made between those that took place before the implementation of the national meteorological management system, which took place in 2004.

Figure 1 shows the breakdown of the number of cases per year for the analysed period and the maximum number of cases was recorded in 2009 and in 2017. The minimum recorded it was in 2007, when 3 cases were registered. With an average of 8.23 cases per year, this phenomenon is more frequent in the analysed period compared to the reference period 1981-2010 where an average of 6.4 cases per year is recorded and close to the reference period 1991-2020, where 7.3 cases per year are recorded.



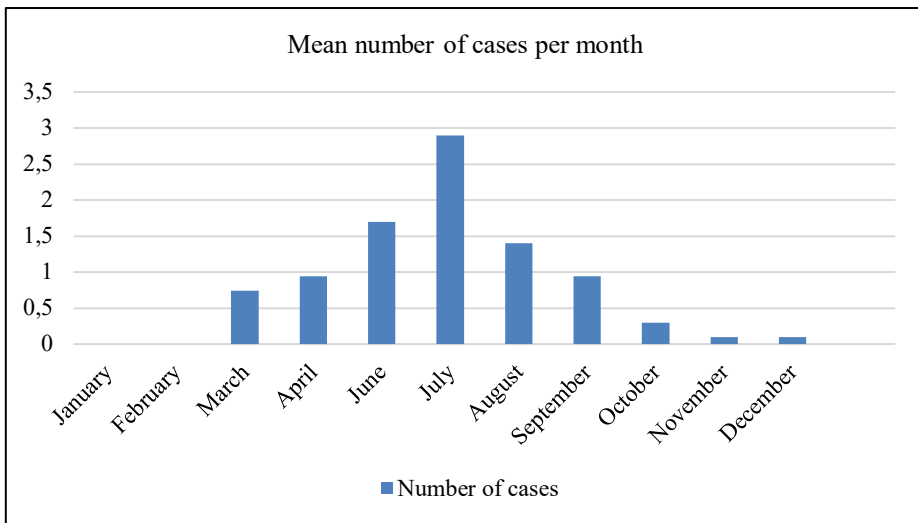
**Figure 1** Number of squall events in the timescale 2000 – 2020 and the mean value



Frequently associated with squalls are updrafts and downdrafts. These exceptionally strong small-scale wind movements which induce outburst of damaging winds near the ground are one of the most severe squall line associated threats. Another factor which influences the severity of wind gusts is the thermal and baric amplitude. The intensity at which tornadoes can occur is closely related to the temperature difference between the warm air mass and the cold air mass, but it also depends on the angle of rotation of the wind ahead of the cold front. If the rotation angle approaches 90 degrees or exceeds this value, then the squalls will be stronger. It can also be mentioned that wind intensifications reached, for a short period of time, average values of very violent storms (Bogdan, 1983; Furtună, 2020).

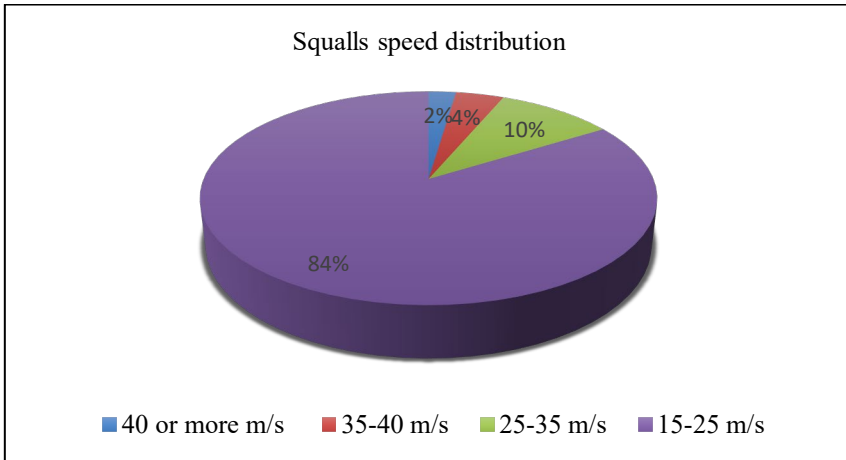
The decrease in the number of squall events in some years according to figure 1 can be explained by the mean zonal circulation, which can be influenced by a number of other factors, as for the western part of Romania by a blocking circulation in the middle of the Azores high pressure area.

Figure 2 depicts a brief climatology of the squall phenomenon. Because squalls and squall line are associated with cold fronts, the majority of the cases occur during the summer months. The peak is reached in July and the least occur in either November or December. The cases which may occur during the winter months are a result of the advection of hot and humid air from the northern part of Africa and the advection of cold and dry air, which originates from the northern latitudes.



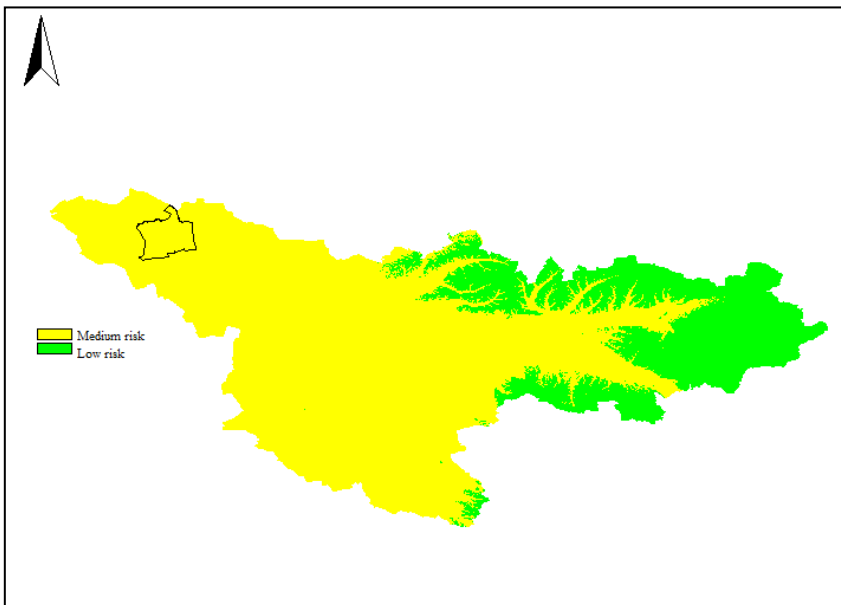
**Figure 2** Mean number of squall events per month in the timescale 2000 – 2020

Figure 3 depicts the speed distribution of squalls for the researched timescale. It shows that the majority of squalls tend to have a speed between 15 and 25 m s<sup>-1</sup>. As such, there are also cases where the speed varies between 25 and 35 m s<sup>-1</sup>. These cases account for around 10%, while the extreme cases, where the speed exceeds 35 m s<sup>-1</sup> or even more than 40 m s<sup>-1</sup> account for around 6%.



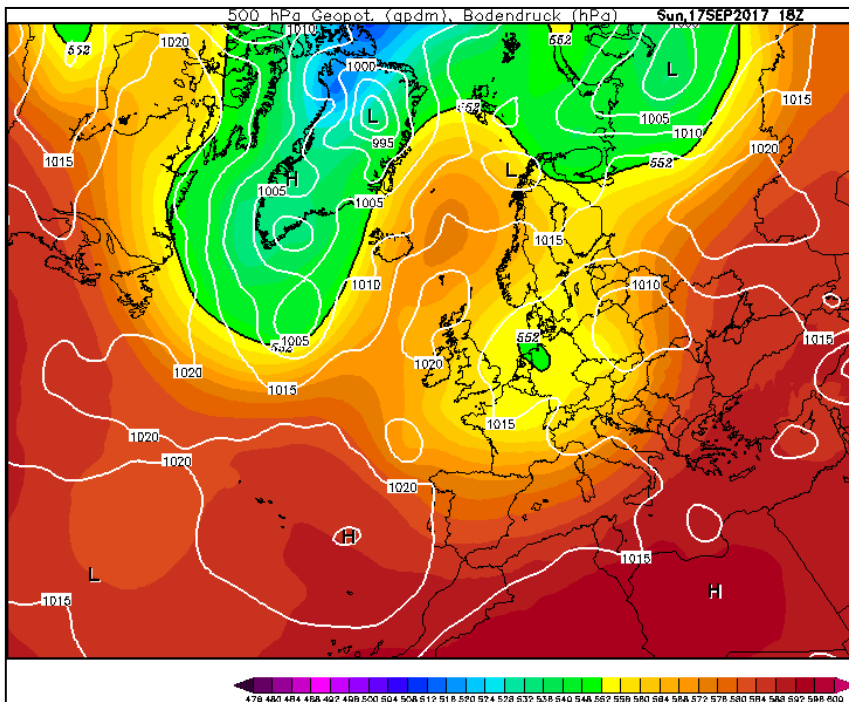
**Figure 3** Distribution of squalls speed for the timescale 2000 - 2020

Figure 4 shows the risk assessment for squalls and squall lines in the western part of Romania as modelled for the timescale 2020-2040. This estimation, which was done using ArcGIS software, uses data from the western-most station as parameters in order to establish a risk map for squalls and squall lines. A low risk means that the probability of squalls with speeds exceeding  $30 \text{ ms}^{-1}$  is lower than 20%, while medium risk means that the probability of squalls with wind speeds exceeding  $30 \text{ m s}^{-1}$  ranges between 40 and 50%.



**Figure 4** Squalls risk assessment projected for the period 2020 – 2040

The development of squalls as part of a synoptic system is normal for the western part of Romania, due to the western and quasi-western circulation, which play a role in the advection of warm and humid air from the lower latitudes. In contrast with the cold and dry air which originates from the northern part of Europe, the western part of Romania tends to be an accumulation pool for both air masses. As such, the formation of a cold front is very probable, and its effects are felt throughout the entire region. The eastern-most part of Timiș county tends to register an increase in the hail cases, while the western part of the county tends to register higher wind speeds, most of them in the range of 15 to 25 m s<sup>-1</sup>. As far as the squalls are concerned, the risk imposed upon agriculture is quite a threat upon agriculture and upon farming in the western part of Romania, due to the destructive power of the wind, especially winds which originate from convective structures.



**Figure 5** Synoptic chart depicting the situation on the 17<sup>th</sup> of September 2017 (processed from [www.wetterzentrale.de](http://www.wetterzentrale.de))

One of the most important severe weather events, which took place on the 17<sup>th</sup> of September 2017, affected the entire western part of Romania on an important scale. The squall line, which formed in the southern part of Europe due to the temperature amplitude between two air masses, went on to create one of the most destructive squalls ever recorded in the climatological archives. Downdrafts with speeds reaching 35 and even 40 m s<sup>-1</sup> produced damages of more than one million euro for the agriculture-related business in the western part of Romania. The significant low-level moisture together with the cold air, which originated

from a cut-off low from the northern part of Germany produced a phenomenon which was out of the ordinary for even the most experienced forecasters.

Squall line with lower wind speeds have already been registered in the western part of Romania, but the case of September 17<sup>th</sup> has been unique with regard to the agriculture-inflicted damage. The advection of cold air was a stress factor for all the crops which were still not yielded and, as such, the majority of them were therefore lost. This case remains one of the most important with regard to the used of modern atmospheric surveillance equipment for better forecasting of severe weather events.

## CONCLUSIONS

The aim of this study was to emphasize the risk of squalls and of squall line on agriculture. The need for a squall climatology is of maximum importance due to the destructive power of the wind and the damage it imposes upon industry and agriculture. Wind speed during squalls has increased in the western part of Romania and the maximum wind speed has reached a record of more than  $140 \text{ km h}^{-1}$ . With regard to windshear speed, data from Timișoara airport shows that the mean windshear has increased with  $4.5 \text{ km h}^{-1}$  and that the impact of the wind imposes an urgent response with regard to mitigation strategies and adaptation measures in order to cope with climate change and with side effects of this global phenomenon. The summer months have the highest squall frequency, because of the energy which sets off all convective mechanisms. The majority of the wind speeds during squalls tend to be in the  $15\text{-}25 \text{ m s}^{-1}$  category, which means that powerful winds are to be expected also within single-cell thunderstorms.

## REFERENCES

- Barry, R., Blanken, P. (2016). Microclimate and local climate. Cambridge University Press, United Kingdom.
- Bogdan, O. (1983), Climatic and topoclimatic regions (in Romanian). Romanian Academy Publishing House, București.
- Bogdan, O., Niculescu, E. (1999), The climatic risks in Romania. Romanian Academy Publishing House, București.
- Bojariu, R., Bîrsan, M.V. Cică, R., Velea, L., Burcea, S., Dumitrescu, A., Dascălu, S., Gothard, M., Dobrinescu, A., Cărbunaru, F., Marin, L. (2021). Climate change – from physical basics to risks and adaptation (in Romanian). Printech, Bucuresti.
- Bretschneider, C. (1967). Maximum sea state for the North Atlantic hurricane belt. *Ocean Engineering* 2: 43-52.
- Busuioc, A. (2010). Climate variability and change in Romania (in Romanian). ProUniversitaria, București.
- Busuioc, A., Caian, M., Bojariu, R., Boroneanț, C., Cheval, S., Baicu, M., Dumitrescu, A. (2012). Climate change scenarios in Romania for the timescale 2001-2030. National Weather Service of Romania, Bucharest.
- Furtuna, P. R. (2020). The use of teledetection in detecting and analysing tree falls produced by squalls in the Apuseni mountains. Cluj-Napoca University Press, Cluj-Napoca.
- Hangan, H., Kareem, A. (2021). The Oxford Handbook of non-synoptic wind storms. Oxford University Press, New York.

- Houze Jr, R. (2014). Cloud dynamics – 2<sup>nd</sup> edition. Elsevier, Amsterdam.
- Moldovan, F. (2003). Extreme climatic phenomena (in Romanian). Echinox, Cluj-Napoca.
- Nichita, C., Vasilache, I., A., Mircov, V., D., Petrici, S. (2014). Characteristic baric structures at 500 MB associated with dangerous meteorological phenomena in South Western Romania. Research Journal of Agricultural Science, 46 (2), 223-229.
- Rauber, R., Walsh, J., Charlevoix, D. (2017). Severe and hazardous weather. Kendall Hunt Publishing Company, United States of America.
- Sandu, I., Mateescu. E., Vătămanu. V. V. (2010). Climate change in Romania and its effects on agriculture (in Romanian). Sitech, Craiova.
- Sandu, I., Pescaru, V. I., Poiana, I. (2008). The climate of Romania (in Romanian). Publishing House of the Romanian Academy, București.
- Șerban, E. (2010). Precipitation generated climate hazards in the Western Plain situated to the North of Mureș river (in Romanian). University of Oradea Publishing House, Oradea.
- Soroceac, M. (2013). The climate and its associated risk phenomena in the Banat plain. The Geography Institute of the Romanian Academy, București.
- Taszarek, M., Allen, J., Brooks, H., Pilguy, N., Czernecki, B. (2021). Differing trends in United States and European severe thunderstorm environments in a warming climate. Bulletin of the American Meteorological Society
- Trenberth, K. (2022). The changing flow of energy through the climate system. Cambridge University Press, Cambridge.
- Vasquez, T. (2021). Weather analysis and forecasting – second edition. Weather Graphics Technologies, Palestrine.

---

---



## QUANTITATIVE ANALYSIS OF PRECIPITATION AND THE LIAISON WITH AGRICULTURE IN WESTERN ROMANIA

Vlad MĂRĂZAN<sup>1</sup>\*, Codruța CHIȘ<sup>2</sup>, Antoanela COZMA<sup>2</sup>,  
Rareș HĂLBAC-COTOARĂ-ZAMFIR<sup>1</sup>

\*E-mail of corresponding author: vladmarazan@gmail.com

<sup>1</sup>Department of Overland Communication Ways, Foundation and Cadastral Survey,  
Politehnica University of Timișoara, IA Ioan Curea, 300224, Timișoara, Romania

<sup>2</sup>University of Life Sciences „King Michael I of Romania” of Timișoara, 119<sup>th</sup>, Calea Aradului,  
300645, Timișoara, Romania

### ABSTRACT

*Atmospheric precipitations are meteorological elements with a great discontinuity in time and space, a fact that creates difficulties in their analysis and forecasting. This paper considers the western part of Romania and the western part of the Carpathian range which significantly influences the rainfall distribution function of the direction of the air mass circulation and the area under study. An idealized model of the atmosphere is used with the orographic obstacle influencing the air mass up to the level of the nodal surface situated between 400 and 100 hPa. The amounts of maximum precipitation corresponding to the three average cross profiles of the Carpathian range were determined. In a similar way, the amount of maximum precipitation to fall from a cumulonimbus cloud was estimated for a maximum vertical development. The purpose of this study is to determine the relationship between precipitation of orographic or convective origin and agriculture in order to formulate some relevant conclusions for both agricultural engineering as well as agrometeorology with regard to physical factors. The results show that the quantity of precipitation which originate from convective and orographic lifting has increased, but the total amount of precipitation has decreased due to increased mean temperatures as well as other factors related to climate change.*

**Keywords:** *orography, agricultural engineering, convection, precipitation, climate change.*

### INTRODUCTION

Atmospheric precipitations are meteorological elements that are characterized by a great discontinuity both from the point of view of time and space. This creates difficulties regarding

their analysis and forecast. Within the framework of operational meteorology, attempts are made to reduce errors and increase the time interval in order to issue forecasts and warnings to their beneficiaries, i.e., the population, agriculture and industry (Moldovan, 2003).

The calculation of precipitation, especially in mountainous areas, raises a series of difficulties related to the complexity of the processes and the factors that compete for their production. An important role belongs to the vertical currents in the atmosphere, which on the one hand cause the saturation of water vapor, through the adiabatic expansion of the rising air, and on the other hand, ensure the influx of vapours from the surface of the soil (Soroceac, 2013).

The support for the formation of droplets from clouds is the namely the existence of condensation nuclei. At the same time, an important role is played by the land surface, which ensures the transfer of moisture and heat energy and thus causes changes in the field of vertical currents through orographic and frictional effects (Coppola et al., 2020; Hangan & Kareem, 2021).

In the framework of the elaboration of the precipitation forecast, it is necessary to analyse the evolution of the meteorological fields at the synoptic scale, seeking to establish the meaning of the vertical currents, as well as the condensation potential. For quantitative evaluations, the thermal and humidity characteristics of the air masses must also be determined. The factors generating precipitation depend both on the general synoptic context and on the local conditions in which they act, which have a significant influence on the distribution of precipitation, especially on smaller areas (Bojariu et al., 2015). These local factors can produce a doubling or even a tripling of the amount of precipitation and can also lead to an unequal distribution in their surface and with variable intensities in time and space (Sandu et al., 2008).

Among the local factors, a greater emphasis is set to the orography, which must be considered in relation to the dominant circulation (Bezák et al., 2020). Recent studies (WMO, 2009) have highlighted the fact that combining a method of quantitative assessment of large-scale precipitation with methods of evaluating thermodynamic conditions and convective condensation of moisture, as well as the appropriate introduction of orographic conditions, it will allow to obtain some valuable indications for rainfall forecasting. In this work, the amounts of orographic and convective precipitation are evaluated using a model developed by the World Meteorological Organization, as well as the calculation of the amount of water resulting from a cumulonimbus cloud with a maximum vertical development. These meteorological risk phenomena occur as a result of the manifestation of parameters characteristic only for warm season (Staniforth, 2022). The differential heating, the transfer of hot tropical air or the orographic obstacle are the main causes for the formation of such upward movements of air masses (Hartmann, 2015; Goosse, 2015).

## **MATERIALS AND METHODS**

Considering the influence of mountain range, the physical and mechanical characteristics of air masses are strongly modified depending on the direction of the air circulation and the height of the orographic obstacle (IPCC, 2012).

The mountain ranges, acting as an obstacle to the air masses, change both their direction and movement as well as the thermodynamic structure, resulting in increased cloudiness



accompanied or not by precipitation. The model described in this paper (WMO, 2009) assumes laminar air current and considers that the air flow in the vertical plane makes a right angle with the mountain ridge. The coordinate system is chosen so that the ordinate axis is in the direction of the current, and the abscissa axis is in the vertical plane. The advantage of this model is that it can be used both for both single layer and for several layers. The calculated amount of precipitation represents the difference between the precipitable water at the base of the mountain range and the precipitable water above the ridge. At a higher altitude, which is considered the isobaric surface of 300 hPa, also named nodal surface, the air current is horizontal (Beșleăgă, 1972).

In the experimental case of this work, a single layer is used and the amount of precipitation was determined according to the formula (WMO, 2009):

$$R = \frac{V(W_1 - W_2 * \frac{\Delta P_1}{\Delta P_2})}{Y}, \quad (1)$$

where:

R – precipitation quantity mm h<sup>-1</sup>;

V – wind speed mean expressed as cm s<sup>-1</sup>;

W<sub>1</sub> – precipitable water at the mountain base;

W<sub>2</sub> – precipitable water at the mountain top;

ΔP<sub>1</sub> – pressure variation from surface to 300 hPa;

ΔP<sub>2</sub> – pressure variation from mountain top to 300 hPa;

Y – horizontal orographic slope projection, the distance from the mountain base to the top.

Air density, water vapor density, gravitational acceleration and pressure variation are also taken into account in this equation. Regarding the maximum height of the convective clouds, this parameter can be determined from the aerological analysis or by using the weather radar. The amount of precipitation can be determined both mathematically by applying formulas and with the help of atmospheric research and surveillance equipment. In the case of this paper, data obtained from the meteorological archives from the station on Vârful Țarcu, from Caraș-Severin County will be presented in order to highlight the importance of orography and to be able to compare the data obtained from two stations of different origin, i.e., mountain and plain. The analysis period refers to the spring-autumn season of the period 2017-2021 and the data were processed in accordance with the requirements of the World Meteorological Organization (Sandu et al., 2010).

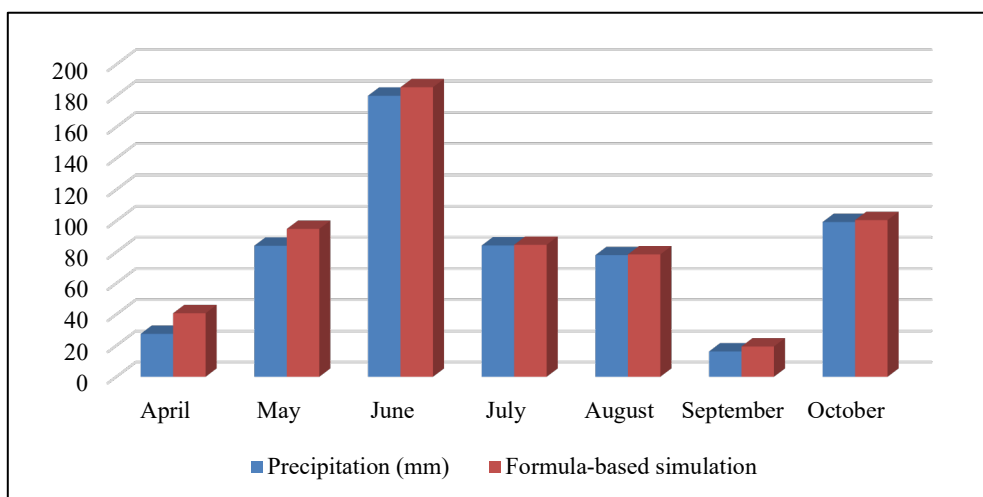
To calculate the amount of precipitation, through the orographic model used in relation 1, in the specific relief conditions of the studied area, the profile of Vârful Țarcu in Caraș-Severin County was calculated, thus evaluating the heights and the average orographic gradient. Also, the entire Carpathian chain was taken into account as an idealized model. Thus, just to compare the situation, it can be mentioned that there is a differentiation depending on the layout of the slope. From the point of view of the disposition of the slopes, the Apuseni Mountains are oriented in the north-south direction, which is significant for the western circulations, while the Southern Carpathians are oriented from west to east, as such being significant for the northern and southern circulations.

As for the V component, it represents the arithmetic mean of the components normal to the orographic obstacle of the wind vector in the 1000-400 hPa layer, and for the W<sub>1</sub> and W<sub>2</sub>

values, precipitable water between 1000 and 300 hPa was considered, the level of 300 hPa being considered the level of the nodal surface. To evaluate W1 and W2, the pressure and temperature at the station level, the condensation level and the height of the mountains were considered, these elements were reduced to the surface level of 1000 hPa. Convective precipitations arise as a result of the existence of specific thermodynamic conditions, either within frontal structures or inside unstable air masses with a rich moisture content. The intensity and location of convective processes directly depend on the interaction of the processes taking place at synoptic scale with those that take place at the mesoscale. In this study, both the interactions between the synoptic systems and the mesoscale ones were used, as well as the instability structures specific to the air masses in the context of the interaction with the relief or with other air masses with properties that lead to the formation of torrential precipitation (Busuioc, 2010).

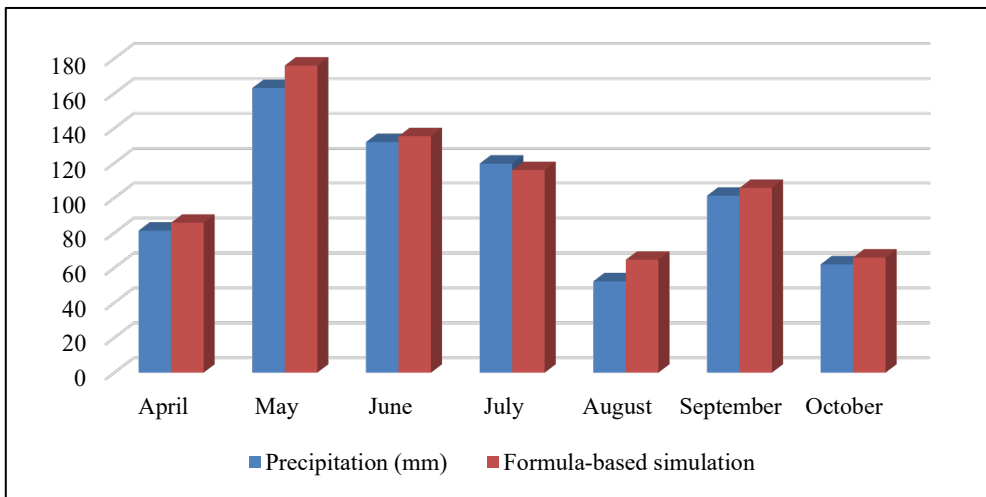
## RESULTS AND DISCUSSION

By using the described model, precipitation amounts were calculated for the period between the spring and autumn seasons of 2017-2021. The time period considered in this study is between April and October, a period in which the energy flow was strong enough to develop and support thermal convective systems and orographic convective systems and thus could generate significant amounts of precipitation. It is not excluded that in other months of the 2017-2021 period, such structures may have taken place, but for the use in agriculture, the time period is considered sufficient. In the analysis, the total amounts of precipitation are taken into account, and at the end, taking into account the distribution and amount of precipitation, by using the data from the radar and satellite archive, the type of structure was determined for each case that determined precipitation.



**Figure 1** Precipitation for the timescale April to October 2017 for Vârful Țarcu station from both simulated as well as actual values

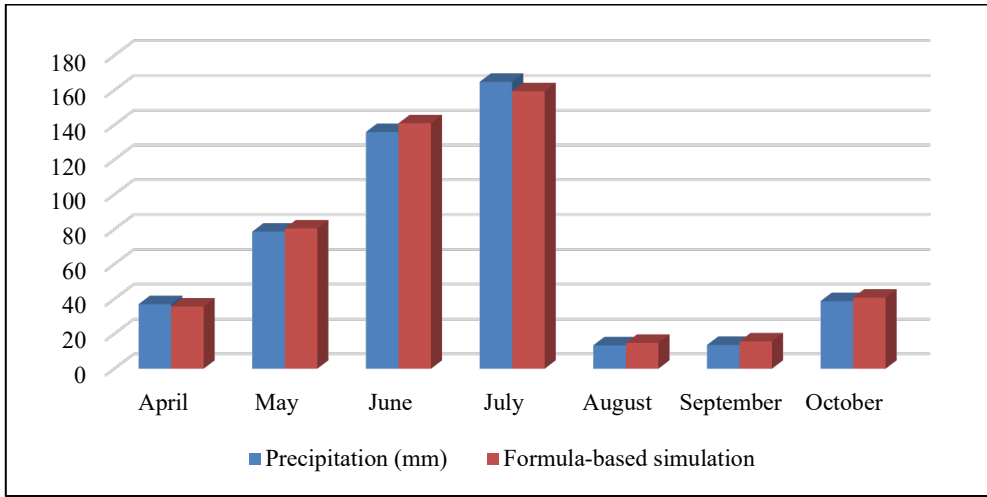
The analysed period from 2017 shows overestimation of the mathematical model at the beginning of the period characterized by atmospheric instability, that is, in April and during May, even in June. In the case of July and August, the values were in the same gap, so the mathematical model estimated less than 1 mm of precipitation in the research area. The error was even lower in August, and in October there was an overestimation of just over 1 mm of precipitation. It is thus observed that the maximum precipitation values were recorded in June, with the value of 180 mm during the 30 days' month (figure 1). The minimum amount of precipitation was recorded in September, when approximately 16 mm of precipitation was recorded at the Vârful Țarcu weather station. Thus, an amplitude of approximately 164 mm is observed, but these results do not represent an indication of a dry period, but only emphasize the importance of the representativeness criteria of the weather stations.



**Figure 2** Precipitation for the timescale April to October 2018 for Vârful Țarcu station from both simulated as well as actual values

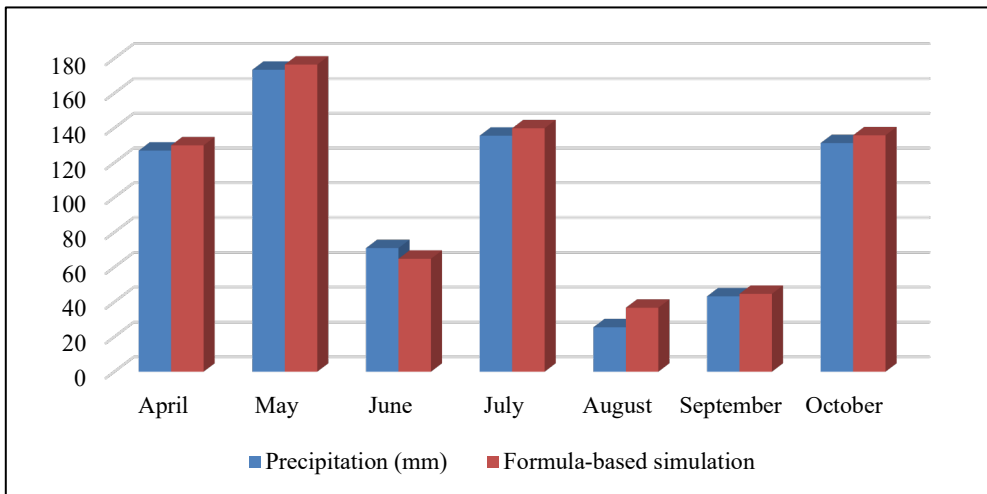
The values for the analysed period of 2018 show quite pronounced differences, especially in April and May due to some overestimations. The causes of these overestimations in the mathematical model indicate a lower wind speed in mountain dynamics and a slowing of the updraft speed in terms of orographic convection. The maximum value was recorded in May, and the minimum in August (figure 2). The amplitude was about 111 mm.

The analysed period of 2019 shows some values that are in agreement with those recorded at the station. There is an underestimation in July and an overestimation in June. These aspects might be explained because of the field of areal dynamics, i.e., a difference given by local factors, such as wind speed or the caloric capacity of clouds. It can be observed that the summer season presents quantitatively significant precipitation in the beginning (July), and the minimum of the analysed period of 2019 was reached in August (figure 3). The amplitude of the period April - October 2019 is approximately 150 mm. From the synoptic analysis, it can be seen that the westerly circulation was less intense during August - September 2019, and the amounts of precipitation that fell in the study area were relatively low.



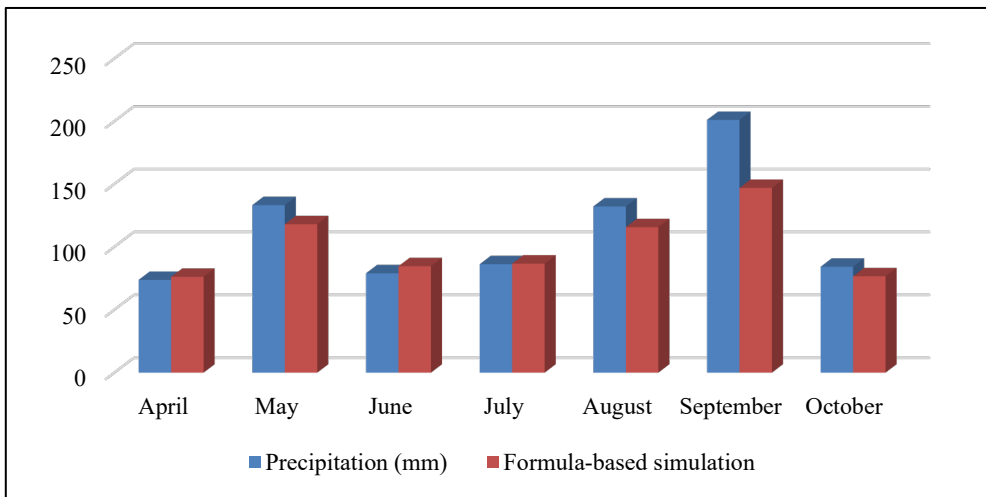
**Figure 3** Precipitation for the timescale April to October 2019 for Vârful Țarcu station from both simulated as well as actual values

The period April - October 2020 was characterized by a pronounced amplitude in August compared to the values obtained by mathematical methods. The difference occurred due to some systems that initially have had a low speed of movement, and upon contact with the mountainous relief, were forced to either trigger the precipitation or to continue the ascent and produced precipitation in other areas that were not included in the area of research.



**Figure 4** Precipitation for the timescale April to October 2020 for Vârful Țarcu station from both simulated as well as actual values

However, the month of August recorded the lowest amount of precipitation, and during the month of May, the third highest amount of precipitation was recorded in the current climatological reference period, as such, 1991-2020. August amounts totalled about 25 mm of precipitation, and the mathematical model overestimated by about 10 mm. May, on the other hand, recorded 173 mm of precipitation, and the mathematical model recorded 176 mm. The difference is insignificant, so for large quantities it can be considered that the model gives viable results. The amplitude for the analysed period of 2020 is approximately 148 mm, and figure 4 shows a pattern regarding the distribution of precipitation for the analysed period. The months of August and September were low from the point of view of the amounts of precipitation, but this aspect was compensated by the abundance of precipitation from the previous months.

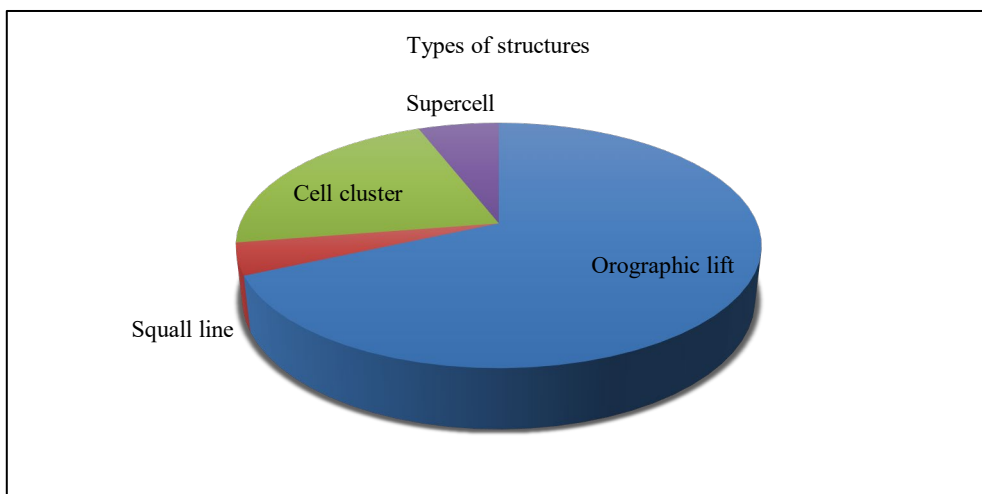


**Figure 5** Precipitation for the timescale April to October 2021 for Vârful Țarcu station from both simulated as well as actual values

Figure 5 shows the distribution of precipitation for the months in which orographic convection or circulations that give rise to deep convection occur in the mountain area. The month of September was the richest in precipitation, and the modelling produced the biggest difference between the estimated amount and the actual amount, followed by August and May. Among the analysed months, it can be observed that July presented similar values both for modelling and for diagnosis according to climatological data.

The obtained results showed that the influence of the orography on the amounts of precipitation is much more significant in the cases of a higher average normal wind component. Higher wind speeds can produce changes in the distribution of precipitation because they help move cell clusters and indirectly spread precipitation over a larger area. The differences recorded during the month of September of 2021 represent an overlap of several structures that formed before sunset and that had similar characteristics, and the quantities were correctly estimated using the atmospheric surveillance equipment, as such, the meteorological radar from Timisoara.

The analysed period of 2021 presents quasi-uniform amounts of precipitation, with the exception of the month of September, where the cumulative amounts of precipitation reached the record value of 200 mm. The month of April recorded the minimum amount of precipitation, but this aspect is closely related to an atmospheric blockage located in the west of Europe, which did not allow the air masses of Mediterranean and even of North African origin to penetrate the European continental space. The amplitude for the period April - October 2021 was approximately 128 mm, and the quasi-uniform distribution of precipitation was visible especially at the end of the spring season and the beginning of the summer season, as such, the months of June and July. The significant difference between the value obtained from the application of the formula and the value recorded at the station is an argument to also use the estimates from the atmospheric monitoring equipment. Also, from the point of view of operational meteorology, it is also relevant that squall lines structures can cause such precipitation accumulations in a fairly short interval and the results can be tracked with the help of meteorological radar.



**Figure 6** Structures associated for the timescale April - October 2017-2021 at Vârful Țarcu station

Most of the precipitation presented in this study had as its source orographic convection. This was followed by the cluster of convective cells, followed by supercells and squall lines (figure 6). Regarding the distribution of precipitation in the mountain area, it can be reiterated that they can take place over a larger area, and it is not necessary to compile a local climatology with a special purpose for agriculture (Vasquez, 2012).

However, an analysis of the climatology of heavy precipitation is necessary, especially in the areas at the base of the slopes, where there may be agricultural areas. Precipitation is necessary for agriculture, but torrential accumulations do not produce a benefit in this field, but rather damage and destruction of both anthropic and non-anthropoc habitats (Şerban, 2010).

It should be noted that there are risks associated with precipitation that can produce flash floods, namely the local degradation of the soil and especially of the biota (Scorzini et al., 2021).

Due to the fact that the analysed area is a mountainous area, characterized by relatively steep slopes and without hydrotechnical constructions, the risk of floods is increased and the flooding of agricultural lands at the foot of the slopes is increased (Bauer et al., 2019; Săulescu, 2014).

Another aspect in terms of methodologies for adapting to climate change is familiarity with such structures that can produce significant amounts of precipitation in short periods of time. Clusters of convective cells, although they represent the second type of structure associated with convection in the mountain area, represent a danger for the agricultural field due to the potential hailstorms both in the mountain area and in the plain area (Nichita et al., 2014).

## CONCLUSIONS

The present study wants to be an argument for the use of effective methods for forecasting the amounts of precipitation even in areas where there is no meteorological station. Although the estimates are not always accurate, a threshold can be established to use the methods presented above to estimate the amounts of precipitation according to the topoclimatic conditions in a certain area. From the point of view of the agricultural engineering, this aspect is a positive one due to the fact that it allows some types of estimates to be made by agricultural engineers and in over 85% it is acceptable while it falls within the pattern. As such, it is rendered to be used as a good method for general estimation of the amount of precipitation, and in the case of torrential rains, this aspect must be improved. It should be noted that there is a tendency of decrease with regard to the amount of precipitation during a calendar year and an increase in what means the amount of precipitation fallen during a cold frontal passage or an unstable air mass. These aspects are closely related to climate change, which produces effects at the global, regional and local levels. In this study, a significant accumulation of precipitation of orographic origin or even due to air mass instabilities was highlighted, which indicates a trend in what climate change means. The amount recorded during September 2021 of over 200 mm represents an argument for the use of both atmospheric monitoring systems (weather radar) and the use of much higher resolution forecast models to cover each area of interest, both mountain and lowland areas where there are risks. The use of the method analysed in this work is an additional help for the meteorologist from the operational point of view as well as for the agricultural engineer to be able to make decisions and implement better adaptation strategies even if the differences can sometimes be significant. The most important aspect in highlighting these strategies for avoiding dangerous meteorological phenomena for agriculture is the investment in multidisciplinary operational research and in meteorological equipment.

## REFERENCES

- Bauer, M., Dostal, T., Krasa, J. et al. (2019). Risk to residents, infrastructure and water bodies from flash floods and sediment transport. *Environmental Monitoring and Assessment*, volume 191.
- Beșleagă, N. (1972). *Dynamic meteorology elements*. Publishing House of the Academy, București.

- Bezak, N., Borrelli, P., Panagos, P. (2020). A first assessment of rainfall erosivity synchrony scale at pan-European scale. *CATENA*, volume 198.
- Bojariu, R., Bîrsan, M. V., Cică, R., Velea, L., Burcea, S., Dumitrescu, A., Dascălu, S. I., Gothard, M., Dobrinescu, A., Cărbunaru, F., Marin, L. (2015). *Climate change – from physical basis to risk and adaptation*. Printech Publishing House, Bucharest.
- Busuioc, A. (2010). *Climate variability and change in Romania (in Romanian)*. ProUniversitaria, București.
- Coppola, E., Sobolowski, S., Pichelli, E. et al. (2020). A first-of-its kind multi-model convection permitting ensemble for investigating convective phenomena over Europe and the Mediterranean. *Climate Dynamics* vol. 55, 3-34.
- Goosse, H. (2015). *Climate system dynamics and modelling*. Cambridge University Press, Cambridge.
- Hangan, H., Kareem, A. (2021). *The Oxford Handbook of non-synoptic wind storms*. Oxford University Press, New York.
- Hartmann, D. (2015). *Global physical climatology*. Elsevier, Amsterdam.
- IPCC. (2012). *Managing the risks of extreme events and disasters to advance climate change adaptation. A special report of Working Groups I and II of the Intergovernmental Panel on Climate Change*. Cambridge University Press, Cambridge.
- Moldovan, F. (2003). *Extreme climatic phenomena (in Romanian)*. Echinox, Cluj-Napoca.
- Nichita, C., Vasilache, I. A., Mîrcov, V., D., Petrici, S. (2014). Characteristic baric structures at 500 MB associated with dangerous meteorological phenomena in South Western Romania. *Research Journal of Agricultural Science*, 46 (2), 223-229.
- Sandu, I., Mateescu, E., Vătămanu, V. V. (2010). *Climate change in Romania and its effects on agriculture (in Romanian)*. Sitech, Craiova.
- Sandu, I., Pescaru, V. I., Poiana, I. (2008). *The climate of Romania (in Romanian)*. Publishing House of the Romanian Academy, București.
- Săulescu, N. (2014). *Climate change – a major challenge for agricultural research*. Publishing House of the Romanian Academy, București.
- Scorzini, A. R., Di Bacco, M., Manella, G. (2021). Regional flood risk analysis for agricultural crops: Insights from the implementation of AGRIDE-c in central Italy. *International Journal of Disaster Risk Reduction*, volume 53.
- Șerban, E. (2010). *Precipitation generated climate hazards in the Western Plain situated to the North of Mureș river (in Romanian)*. University of Oradea Publishing House, Oradea.
- Soroceac, M. (2013). *The climate and its associated risk phenomena in the Banat plain*. The Geography Institute of the Romanian Academy, București.
- Staniforth, A. (2022). *Global atmospheric and oceanic modelling*. Cambridge University Press, Cambridge.
- Vasquez, T. (2012). *Severe storm forecasting*. Weather Graphics Technologies, Garland.
- World Meteorological Organization. (2009). *Manual on estimation of probable maximum precipitation (PMP)*.





## DEVELOPMENT OF CHICKEN EGGSHELLS POWDER AS AGRICULTURAL FERTILIZER AND SOIL CONDITIONER

Antoanela COZMA<sup>1</sup>, Ariana VELCIOV<sup>1</sup>, Iasmina Madalina ANGHEL<sup>2</sup>, Bogdan COZMA<sup>1</sup>, Vlad MĂRĂZAN<sup>3\*</sup>

E-mail of corresponding author: vladmarazan@gmail.com

<sup>1</sup>Department of Soil Science, University of Life Sciences "King Michael I" from Timisoara, 300645, Timisoara, Romania

<sup>2</sup>Materials and Manufacturing Engineering Department, Politehnica University of Timișoara, 300222, Timișoara, Romania

<sup>3</sup>Department of Overland Communication Ways, Foundation and Cadastral Survey, Politehnica University of Timișoara, 300006, Timișoara, Romania.

### ABSTRACT

*The aim of the paper is to obtain eggshell powder from poultry egg waste in order to use it as a mineral fertilizer for the cultivated soils of the own households. We proceeded to the preparation of powder from chicken eggs derived from eggs of free laying hens, fed with cereals and determining the mineral profile. The results obtained from the analysis of mineral elements show that (in the conditions of the present experiment), eggshell powder contains high amounts of calcium (34.21- 38.16%), magnesium (0.34 – 0.53%) and appreciable amounts of microelements: (3.23- 4.57 ppm) iron, (6.41- 8.72 ppm) Zn, (0.34 – 5.01 ppm) manganese and (4.36- 6.03 ppm) copper. These data show that the analyzed poultry eggshell powder can be used as a fertilizer with macro and microelements (Ca, Mg respectively: Fe, Mn, Zn, Cu) for the mineral enrichment of cultivated soil in home gardens or planters. In addition, the advantage of using poultry eggshell powder, compared to other natural sources of calcium, is the extremely low level of toxic substances. Also, due to the increased of calcium content, eggshell powder helps to correct the pH of acidic soils and to immobilize cadmium and lead in contaminated soils. It can be said that poultry eggshell powder can be recommended both as an organic fertilizer, which increases the mineral supply of plants, and as a soil conditioner, improving the health of plants.*

**Keywords:** poultry eggshell powder, microelement, macroelement, agricultural fertilizer, eggshell waste

## INTRODUCTION

In many countries around the world, the egg processing companies, also some food manufacturers that use eggs in their products, produce tons of eggshell waste whose final destination is a challenging environmental impact (Liu et al., 2021; Wijaya and Teo, 2019; Ali and Badawy, 2017). Accidentally discarded, without any pretreatment, these piles of eggshells cause serious environmental problems, including unpleasant odors, insect noise and abrasiveness. This waste provides a habitat for harmful insects and bacteria that can cause infectious diseases, allergies and other unpleasantness to local residents (Laohavisuti et al., 2021; Owuamanam et al., 2021; Afzal et al., 2020; Bradauskiene et al., 2017; Ray et al., 2017; Madhavi and Chakraborty, 2016). Eggshells are waste materials produced in huge amount by poultry industry houses, restaurants and the domestic activities of food preparation (Burezq, 2021; Chakraborty and Datta, 2019). These wastes could be recycled and converted into valuable calcium compounds by various methods in an environmentally friendly nature, which is a good choice for zero waste management (Laohavisuti et al., 2021; Burezq, 2021). To minimize environmental problems, eggshell waste residues should be effectively managed by recycling and reuse and/or turning them into a valuable product. In order to form an image regarding the recycling of eggshell waste into valuable products needed for agriculture, food industry, medicine and other industrial activities, we present data regarding the composition and nutritional properties of chicken eggshell. Chemically, chicken eggshell is composed of water (2%), solid material (98%), protein (5%) and ash (93%) (Khan et al., 2021). The proximate chemical composition of different kinds of eggshell powders, obtained by recycling eggshell waste, is presented in table 1 (Zulkeflee et al., 2020; Ali and Badawy, 2017).

**Table 1** Proximate chemical composition of different kinds of eggshell powders.

Components (g/100g)	Eggshell powders (% on dry weight basis)				
	Chicken	White chicken	Brown chicken	Duck	Quail
<b>Moisture</b>	0.55 ± 0.02	0.95±0.12	1.09±0.26	0.76±0.15	1.02±0.16
<b>Crude protein</b>	3.66± 0.10	3.17±0.32	2.69±0.21	2.95±0.29	3.54±0.12
<b>Fat</b>	0.02±0.10	0.06±0.02	0.06±0.01	0.05±0.02	0.04±0.01
<b>Ash</b>	94.40±0.03	96.67±0.4	96.18±0.71	95.99±0.16	93.42±1.66
<b>Crude fiber</b>	50.77±0.12	0.002±0.00	0.003±0.00	0.002±0.00	0.003±0.00
<b>Carbohydrates</b>	-	0.098±0.00	1.06±0.01	1.00±0.00	2.99±0.01

As can be seen from Table 1, eggshell powder is a highly concentrated source of minerals, containing over 94% ash content. In addition to calcium, eggshell powder also contains important amounts of magnesium and smaller but appreciable amounts of other mineral elements, including iron, zinc, copper, manganese, sulfur, silicon (Arif et al., 2022; Burezq, 2021; Liu et al., 2021; Ali and Badawy 2017; Islam et al., 2019; Park and Sohn, 2018; Ajala et al. 2018; Al-awwaland Ali, 2015; Hassan, 2015; Schaafsma et al., 2000).

The mineral eggshell composition, according to different authors, is presented in Table 2. The mineral eggshell composition varies widely, this being dependent on a number of factors such as: the breed and age of the bird origin, the feeding method and the growing conditions (cage and free-range), etc. (Liu et al., 2021; H. T. Dao et al., 2020; Islam et al., 2019; Ali and Badawy, 2017; Schaafsma et al., 2000). Considering the chemical composition of bird eggshells, especially the increased content of minerals, these residues could be recycled and transformed, through different methods, in an ecological nature, into valuable calcium compounds which is a good choice for zero waste management. (Laohavisuti et al., 2021; Arabhosseini and Faridi, 2018).

**Table 2** Mineral composition of some chicken eggshells.

Mineral contents	According to the researchers					
	Arif et al., 2022	Liu et al., 2021	Ali and Badawy, 2017	Al-awwal et al., 2015	Hassan, et al., 2015	Schaafsma et al., 2000
Total ash, g /100 g	94.28-94.69	94.61	-	89.9–91	190.2	ND
Calcium, mg/100 g	36200	33130-34120	10800-11300	35100–35400	35080	40100
Magnesium, mg/100 g	240	290-360	380-500	370–400	262.0	450
Phosphorus, mg/100 g	ND	ND	-	120	150.2	99
Iron, mg/100 g	11.47	<0.1-2.2	-	ND	13.06	2.24
Zinc, mg/100 g	0.67	<0.1	ND	ND	145.1	0.513
Sodium, mg/100 g	80	30-40	169.4 - 189.4	150–170	47.9	ND
Potassium, mg/100 g	60.200	40-50	36.6 - 45.6	100–130	50.00	ND
Copper, mg/100 g	ND	<0.1	-	ND	4.1	0.77
Manganese, mg/100 g	ND	<0.1	0.30 – 1.12	ND	149.9	ND
Strontium, $\mu\text{g/g}$	ND	ND	-	ND	ND	372
Fluorine, $\mu\text{g/g}$	ND	ND	-	ND	ND	3.75
Selenium, ng/g	ND	ND	-	ND	ND	23.5

ND - not determined

Eggshell waste can be processed into more useful products, such as: natural fertilizers and amendments in agriculture and animal feed, mineral additives in the food industry, medicines as calcium supplements, and composite materials or construction materials, in producing biodiesel etc. (Burezq, 2021; Laohavisuti et al., 2021; Radhika Y, et al., 2020; Dave et al., 2020; Zulkeflee, et al., 2020; Chakraborty and Datta (De), 2019; Ajala et al., 2018; Arabhosseini and Faridi, 2018; Bartter et al., 2018; Dolińska et al., 2016; Ok et al., 2011; Schaafsma et al., 2000).

Waste recovery in useful products for agricultural activities was in the attention of many researchers. There is a serious concern for using eggshell to improve soil properties in terms of soil reaction, mineral nutrient content (especially calcium, magnesium and trace elements) or the blocking of heavy metals, so as to meet the plants' requirements. According to Radhika (2020), eggshell powder is a good garden fertilizer for vegetables or flowers. The using of eggshell waste as a fertilizer was also recommended by Wijaya and Teo (2019) which shows that due to its mineral content, eggshells have the potential to become a fertilizer for the crop plants. The recovery of eggshells as calcium phosphates used as fertilizers for agriculture or as animal feed is also recommended (Laohavisuti et al., 2021). Using eggshell as fertilizer has an effect not only of increasing the calcium content and, to a lesser extent, the content of microelements, but also the improvement of soil pH, a very beneficial measure for different plants. By using crushed eggshell as fertilizer, the calcium content of the soil can be increased along with other nutrients contained in the eggshell (Arabhosseini and Faridi, 2018). The importance of using eggshell powder as a fertilizer especially due to the increased content of calcium, an essential element for plant growth and development, was also demonstrated by Dattatray and Nair (2019). Eggshell waste can also be used to immobilize cadmium and lead from soils polluted with such heavy metals in a contaminated soil. Ok et al. (2011) show that the metal bioavailability in the heavy metal-contaminated soil may be reduced with the eggshell treatment as a lime-based waste material. The authors of these studies conclude that eggshell waste can be used as an alternative to  $\text{CaCO}_3$  for the immobilization of heavy metals in soils. Eggshell is also an efficient material in removing heavy metals, such as copper and zinc, from water solutions contaminated with such potentially toxic metals. To exploring the eggshell from household waste as alternative adsorbent for heavy metal removal from wastewater, Badrealam (2020) concluded that application of eggshell as new adsorbent material can be a good alternative for industrial wastewater treatment due to its low cost media. Hence, the use of eggshell could help to overcome the excessive Cu and Zn problem in wastewater treatment plant. Calcium carbonate from eggshells is similar to the common soil additive lime, which is probably the best natural source of calcium for plants. Biochemical parameters such as chlorophyll, amino acids, protein and total phenol also increase with the increasing of hen eggshell concentration. Using eggshells as an alternative calcium carbonate source for peanuts can reduce the impact on natural limestone reserves, a natural non-renewable source also investigated by Vu et al. (2022). The authors of this study highlighted the effects of eggshell powder application on the growth and yield in the peanut. Studying the effect of eggshell powder on the stabilizing potential of lime on an expansive clay soil, Amu et al. (2005) reported that ESP cannot successfully replace lime as a material for effective stabilization unless some further researches are conducted. However, eggshell powder could be used for stabilization of soil where very high subgrade performance is not necessary. Calcium from eggshell it is the best natural source of calcium better than limestone, which is approximately 90% absorbable (Burezq, 2021). Therefore, the transformation of eggshell into animal feed would turn her into a valuable product, which bring economic benefits to the

poultry industry. From the presented data it can be stated that, due to the increased mineral content, especially calcium and magnesium and less microelements (iron, zinc, manganese, copper), chicken eggshell waste can be used in many agricultural activities in the form of mineral fertilizer, as an additive to improve the soil's physical parameters, or reducing the accessibility of lead and cadmium from soils polluted with heavy metals, as a substitute for natural calcium carbonate or as a nutritional improver in animal feeds. To be useful for plant cultivation, soils must contain sufficient amounts and in appropriate proportions of nutrient compounds necessary for their growth and development. Among these nutrients are calcium, magnesium, iron, zinc, manganese and copper, the mineral elements, essential for obtaining rich and quality harvests. The main roles of some mineral elements are shown in Table 3 (Soetan et al., 2010).

**Table 3** Functions and deficiency symptoms of plant macro and microelements (Soetan et al., 2010)

Element	Available form to plants	Major functions	Deficiency symptoms
<b>Calcium</b>	Ca <sup>2+</sup>	Important in formation and stability of cell walls and in maintenance of membrane structure and permeability, activates some enzymes, regulates many responses of cells to stimuli.	Leaves are deformed, terminal buds die, reduced root growth.
<b>Magnesium</b>	Mg <sup>2+</sup>	Mg <sup>2+</sup> Component of chlorophylls, activates many enzymes.	Chlorosis, drooped leaves.
<b>Iron</b>	Fe <sup>3+</sup> , Fe <sup>2+</sup>	Component of cytochromes, electron transport, activates some enzymes, plays a role in chlorophyll synthesis.	Chlorosis, yellow and green striping in grasses.
<b>Manganese</b>	Mn <sup>2+</sup>	Active in formation of amino acids, activates some enzymes, coenzyme activity, required for water-splitting step of photosynthesis, chlorophyll synthesis.	Light green leaves with green major veins, leaves whiten and fall off.
<b>Zinc</b>	Zn <sup>2+</sup>	Active in formation of chlorophyll, activates some enzymes, plays a role in formation of auxin, chloroplasts, and starch.	Chlorosis, mottled or bronzed leaves, abnormal roots.
<b>Copper</b>	Cu <sup>+</sup> , Cu <sup>2+</sup>	Component of many redox and lignin-biosynthetic enzymes.	Chlorosis, dead spots in leaves, stunted growth, terminal buds die, necrosis in young leaves.

The objective of this paper is to achieve a simple method for obtaining chicken eggshell powder from eggshell results as waste from domestic food processing activities that use chicken eggs and determining the content of Ca, Mg, Fe, Mn, Zn and Cu in order to use it as a mineral fertilizer for soils cultivated with trees, vegetables, flowers, etc. It is hoped that the results of this study can contribute to the reduction of eggshell waste, with a negative impact on the environment, and the use of eggshell powder, especially as a mineral fertilizer, thus reducing the cost of using commercial fertilizer.

## MATERIALS AND METHODS

### *Samples*

To carry out the proposed experiment, chicken eggshells resulting from domestic food preparation activities were purchased from three different locations. The eggshells, taken in the experiment, come from backyard chickens, fed with cereals and corn (Figure 1).



**Figure 1** Chicken eggshell

### *Preparation of eggshell powder*

The preparation of eggshell powder was carried out according to the recommendations of Radhika et al. (2020) and Ray et al. (2017). Until the moment of preparing powder, the eggshell collected from household waste was kept in polyethylene bags at 3-5 °C. In the first stage, the eggshells were washed in a jet of tap water for about 5 minutes, and after removing possible impurities and organic residues, they were boiled for approx. 10 minutes in order to eliminate the risk of contamination with Salmonella. In the next stage, the eggshells were dried in an electric oven for 2 hours at 800 °C. After cooling, the eggshells were manually crushed and then ground using a household grinder. The powder obtained in this way, kept in glass jars was analyzed in terms of total concentration in Ca, Mg, Fe, Mn, Cu, Zn.

### *Instrumentation*

- Electric oven used for drying eggshells;
- Household grinder for crushing the eggshells;
- Nabertherm calcination furnace type 6/11 used for samples calcination;
- Atomic absorption spectrophotometer in air-acetylene flame, Varian 280 FS for measuring the absorbance of mineral elements in the standard solutions and from the sample solutions obtained after mineralization.

### Chemicals and Reagents

- Nitric acid Merck, 65 % ( $\rho = 1,39 \text{ g/cm}^3$ ), essential to prepare the 0.5 N nitric acid solution;
- Multi-element standard solution (1g/L) Merck - Germany, used to prepare working standards for Ca, Mg, Fe, Mn, Zn and Cu, in concentrations that cover the concentration range of the elements present in the analyzed samples.

The determination of the mineral elements concentrations in the eggshell samples was carried out using the atomic absorption method in the air-acetylene flame according to the procedure described by Ali, M. and W. Z. Badawy with some modifications (Ali and Badawy, 2017). Practically,  $1 \pm 0.0002 \text{ g}$  of eggshell powder, homogenized in advance, were calcined at  $550 \text{ }^\circ\text{C}$  in two periods of 4 hours each. To prevent sample loss during calcination, before calcination, the sample was treated with 2 mL  $\text{HNO}_3$  65%. After cooling, the ashes obtained was treated with 20 ml of 0.5 N  $\text{HNO}_3$  solution and then evaporated (on the electric stove) until almost dry. The operation was repeated twice, and the solution was quantitatively added with small portions of 0.5 N nitric acid and distilled water, up to a level of 50 ml (Cozma et al., 2021). Determination of the element concentrations from the clear solution brought to the level of 50 ml was carried out using the Varian 280 FS Spectrometer, in air-acetylene flame Spectrometer working parameters: wavelength, air flow and acetylene, etc. were those recommended by the device supplier. Concomitant with the measurement of the analyzed samples and in the same working conditions, the calibration solutions were also measured. For calcium determination, additional dilutions were required. All the mineral composition analyses were performed in triplicate.

## RESULTS AND DISCUSSION

The values result of the essential mineral elements from the researched chicken eggshell powder samples are presented in table 4.

**Table 4** The concentration of some essential elements in chicken eggshell powder

Specification	Essential elements [ppm]					
	Ca (%)	Mg (%)	Fe ppm	Mn ppm	Zn ppm	Cu ppm
<b>Limits</b>	34.21 – 38.16	0.34 – 0.53	32.34 – 45.71	3.40 – 5.01	6.41- 8.72	4.36 – 6.03
<b>Mean values</b>	36.47± 1.66	0.42± 0.08	38.19± 5.58	4.18± 0.66	7.41± 0.82	5.34± 0.71

The data presented in table 3 show that the concentration of mineral elements in the analyzed chicken eggshell powder shows a pronounced non-uniformity, depending on the nature of the essential element and the origin of the eggshells: 34.21 - 38.16% calcium, 0.34 - 0.53% magnesium, 32.34 - 45.71 ppm iron, 3.40 - 5.01 ppm manganese, 6.41 - 8.72 ppm Zn, and 4.36 - 6.03 ppm copper. The results obtained, with some exceptions, fall within the range of values obtained by other researchers, when analyzing similar chicken eggshells

(table 2). The differences can be explained by a series of causes, which condition the mineral profile of chicken eggshell and which were previously presented.

Calcium ( $\text{Ca}^{2+}$ ), important macroelement in formation and stability of cell walls and in maintenance of membrane structure and permeability, activates some enzymes, regulates many responses of cells to stimuli (Soetan et al., 2010), was determined in the highest concentration. The concentration limits (34.21 - 38.16%) and the average concentration ( $36.47 \pm 1.66$ ) of calcium show that this is the predominant mineral element of the eggshell powder analyzed. The increased content of calcium determined in chicken eggshell powder recommends its use as a fertilizer for plant growth and development. Calcium has major role in formation of cell wall membrane in the plant and reduces soil acidity which indirectly improves crop production (Khairnar and Nair, 2019; Radhika et al., 2020).

Magnesium ( $\text{Mn}^{2+}$ ), an essential macroelement, was determined in much lower concentrations than calcium, but much higher than iron, zinc, manganese and copper. This essential element, a component of chlorophylls (in the form of  $\text{Mg}^{2+}$ ), activates many enzymes (Bo Yan and Ying Hou, 2018) was determined in concentration percentages between 0.34 - 0.53%. The amount of magnesium released from soil minerals is generally small compared to the amounts required to maintain high crop yield and quality, so in many agro-ecosystems, the application of fertilizers with this element is crucial (Senbayram et al., 2015).

Iron ( $\text{Fe}^{3+}$ ,  $\text{Fe}^{2+}$ ), an essential microelement in plant growth and development, component of cytochromes, electron transport, activates some enzymes, plays a role in chlorophyll synthesis, was determined in much lower concentrations compared to Ca and magnesium, but higher than the rest microelements: Zn, Cu, Mn (table 3). The iron concentration in eggshells shows values between 32.34 - 45.71 ppm. The average iron content from chicken eggshell ( $38.19 \pm 5.58$  ppm) could contribute to increasing the concentration of iron accessible to plants. However, the use of eggshell as a mineral fertilizer must be done very carefully because too large amounts of carbonates from the eggshell, once they reach the soil solution in the form of bicarbonates, decrease the iron concentration content accessible to the plant (Lampreave et al., 2022).

Manganese ( $\text{Mn}^{2+}$ ) is an essential microelement for plants. It is active in formation of amino acids, activates some enzymes, coenzyme activity, required for water-splitting step of photosynthesis, chlorophyll synthesis (table 3). It was determined in much lower concentrations ( $4.18 \pm 0.66$  ppm) than calcium and magnesium, lower than iron and close to zinc and copper concentrations. By using eggshell as a fertilizer, it must be taken into account that the concentration of  $\text{Mn}^{2+}$  in the soil solution is highly dependent on pH, with levels decreasing rapidly with increasing pH, so deficiencies are more likely to occur in alkaline soils. At a too low pH ( $\text{pH} < 5$ ), Mn can be toxic to sensitive crops. Also, it should be noted that high levels of copper, iron, zinc can reduce Mn absorption (Soetan et al., 2010).

Zinc ( $\text{Zn}^{2+}$ ), essential microelement for plants, this, participating in the formation of chlorophyll, activates some enzymes, plays a role in the formation of auxin, chloroplasts, and starch (table 3.), was determined within concentration limits between 6.41 - 8.72 ppm. The concentration of this essential microelement for plants, whose deficiency is manifested by chlorosis, mottled or bronzed leaves and abnormal roots ( $7.41 \pm 0.82$  ppm) is much lower than Ca and Mg concentrations  $36.47 \pm 1.66$ , respectively  $0.42 \pm 0.08$  %, lower than the Fe concentration ( $38.19 \pm 5.58$  ppm) and slightly higher, but close to the Cu and Mn concentrations ( $5.34 \pm 0.71$  and  $4.18 \pm 0.66$  ppm, respectively). The bioavailability of zinc in



soils is affected both, by soil and source properties (Soetan et al., 2010). The formation of inner sphere complexes, precipitation at high pH, and reaction with phosphates represent the main ways of sequestering zinc in the soil, potentially decreasing its availability for plants (Santos et al., 2019). Therefore, to the utilization of eggshell as zinc fertilizer should be designed in order to avoid these processes that lead to the unavailability of zinc in the soil.

Copper ( $\text{Cu}^+$ ,  $\text{Cu}^{2+}$ ) is an essential microelement for plants which participates in redox processes, photosynthesis, as well as carbohydrate and protein exchange. The concentration of this element, due to which the cultivated plants resist better to fungal and bacterial diseases, their standing stability increases, as well as resistance to droughts and frosts (Lukina and Zhuikovb, 2021) has values between 4.36 - 6.03 ppm. Soil organic matter binds copper more closely than any other micronutrient, so plant-available copper decreases as soil organic matter increases (Soetan et al., 2010). By using chicken eggshell powder as fertilizer, it must be taken into account that the bioavailability of copper from soil decreases with increasing pH; the decreased availability of metals is affected by higher adsorption and precipitation in alkaline and neutral environments (Takáč et al., 2009).

## CONCLUSIONS

Chicken eggshell powder obtained from eggshell waste resulting from domestic activities that use chicken eggs in food preparation contains very high amounts of total minerals (of which approximately 37% Ca).

The distribution of the essential mineral elements in chicken eggshell powder shows pronounced non-uniformity, depending on the nature of the element and the origin of the eggshell. Calcium predominates, determined in an average concentration of 36.47%, followed by magnesium, which was determined in lower concentrations of 0.42%.

Iron, an essential microelement, was identified in much lower concentrations compared to calcium and magnesium (38.19 ppm), but higher than zinc, copper and manganese, determined in concentrations close to 7.41, 5.34 and 4.18 ppm, respectively.

Analyzed mineral profile of eggshell shows that chicken eggshell powder recovered from eggshell waste, can be used as a fertilizer or to improve the quality of the soils in gardens cultivated with trees, vegetables, flowers etc.

In addition, the recycling of eggshells on a large scale can contribute to limiting environmental pollution with such waste and to reduce the necessary expenses for the purchase of mineral fertilizers, amendments, etc.

## ACKNOWLEDGEMENTS

The present paper was funded by the Research Project "Obtaining and characterization of natural extracts with antioxidant and antimicrobial role for use as feed additives and in the food industry ", No 2381/ 31.03.2022.

## REFERENCES

- Afzal F., Mueen-ud-Din G., Nadeem M., Murtaza M.A. and Mahmood S., (2020). Effect of eggshell powder fortification on the physicochemical and organoleptic characteristics of muffins, *Pure Appl. Biol.*, 9(2): 1488-1496
- Ajala E.O., Eletta O.A.A., Ajala M.A. and Oyeniyi S.K. (2018). Characterization and evaluation of chicken eggshell for use as a bio-resource arid zone, *Journal of Engineering, Technology and Environment*, Vol. 14(1):26-40. Print ISSN: 1596-2490, Electronic ISSN: 2545-5818
- Ali M. and Badawy W. Z. (2017). Utilization of Eggshells By-Product as A Mineral Source for Fortification of Bread Strips, *J. Food and Dairy Sci.*, Mansoura Univ., Vol. 8 (11): 455 - 459
- Al-awwal N.Y. and Ali U.L. (2015). Proximate analyses of different samples of eggshells obtained from Sokoto market in Nigeria. *International Journal of Science and Research (IJSR)* 4, 564-566
- Amu O.O., Fajobi A.B. and Oke B.O. (2005). Effect of eggshell powder on the stabilizing potential of lime on an expansive clay soil, *Research Journal of Agriculture and Biological Sciences* 1(1): 80-84.
- Arabhosseini A. and Faridi H. (2018). Application of eggshell wastes as valuable and utilizable products: A review, *Res. Agr. Eng.* Vol. 64, (2): 104–114.
- Arif S., I. Pasha, H. Iftikhar, F. Mehak, Sultana R. (2022). Effects of eggshell powder supplementation on nutritional and sensory attributes of biscuits, *Czech Journal of Food Sciences*, Vol.40, (1): 26–32.
- Badrealam S., Roslan F.S., Dollah Z., Bakar A. A. A. and Handan R. (2020). Exploring the eggshell from household waste as alternative adsorbent for heavy metal removal from wastewater, *Advances in Civil Engineering and Science Technology AIP Conf. Proc.*, 020077-1–020077-6.
- Bartter J., Diffey H., Ying Hei Yeung, O'Leary F., Häslér B., Maulaga W., Alders R., (2018). Use of chicken eggshell to improve dietary calcium intake in rural sub-Saharan Africa, *Matern Child Nutr.*;14(S3): e12649
- Bo Yan and Ying Hou, (2018). Effect of Soil Magnesium on Plants: a Review, *IOP Conf. Series: Earth and Environmental Science*
- Bradauskiene V., Montrimaitė K., Moscenkova E., (2017). Facilities of bread enrichment with calcium by using eggshell powder, In 11th Baltic Conference on Food Science and Technology" Food science and technology in a changing world" Foodbalt Jelgava, Latvia, 27-28 April, pp 91-95. Latvia University of Agriculture
- Burezq H. A, (2021). Utilization of Eggshell as Valuable Products for Sustainable Ecosystem and Agriculture (Review), *Poultry Science Journal* 9(2): 147-165.
- Cozma A., Lato A., Velcirov A., Mihut C., Duma-Copcea A., Rotariu L., Okros A., Marazan V., Rada M., (2021). Evaluation of some essential mineral elements from different infusions of medicinal plants, *Research Journal of Agricultural Science*, Vol 53 No 2, pg. 83-90, ISSN 2066-1843 (printed form).
- Chakraborty S., Santa Datta (De), (2019). Eggshell: An alternative, cheap, bioavailable source of calcium in human diet, *RRJoDST* (2019) 25-33 © STM Journals
- Dao H. T., Swick R. A., Nguyen T. V., Hunt P.W., Hine B.C., Lisle L. and Ruhnke I., (2020). A comparison of eggshell mineral composition between cage and free-range eggs via inductively coupled plasma-optical emission spectrometry, *Animal Production Science*, 60(17) 2060-2067
- Dattatray K. M., and Nair S.S., (2019). Study on eggshell and fruit peels as a fertilizer, *Proceedings of International Conference on Sustainable Development in Association with Novateur Publications IJIERT-ISSN No: 2394-3696 ISBN. No. 978-93-87901-05-6.*
- Dave S., Patil S. and Sachin K Sonawane, (2020). Utilization of eggshell in food system as an alternative source of Calcium, *Indian Food Industry Mag* Vol 2 No 3
- Dolińska B., Jelińska M., Szulc-Musioł B. and Ryszka F., (2016). Use of eggshells as a raw material for production of calcium preparations, *Czech J. Food Sci.*, 34, 2016 (4): 313–317.

- Hassan, N.M.M. (2015). Chicken Eggshell Powder as Dietary Calcium Source in Biscuits. *World J. Dairy Food Sciences*, 10, 199–206.
- Islam M.K., Tusty T.A., Akhand A.A. and N. Ahsan, (2019). Human Uptake of eggshell powder as an alternate source of calcium, *J. Pharm. Sci.* 18(2): 249-255.
- Khan F.A, Ameer K., Qaiser M.A., Pasha I., Mahmood Q., ANJUM F.M., Riaz A., Amir R M., (2021). Development and analysis of bread fortified with calcium extracted from chicken eggshells of Pakistani market, *Food Science and Technology*, Campinas, 41(Suppl. 1):14-20.
- Lampreave M., Assumpta M., Josep Valls J., Montserrat N. and Sánchez-Ortiz A., (2022). Carbonated irrigation assessment of grapevine growth, nutrient absorption, and sugar accumulation in a Tempranillo (*Vitis vinifera L.*) Vineyard, *Agriculture*, 12, 792
- Laohavisuti N., Boonchom B., Wimonmat B., Kittichai Chaiseeda K. & Seesamong S., (2021), Simple recycling of biowaste eggshells to various calcium phosphates for specific industries, *Sci Rep* 11, 15143.
- Liu Y., Wang K.W., Blanchard M., Li C., (2021). Eggshell powder compositions and methods of producing eggshell powder compositions, United States Patent No.: US 11,001,700 B2 (45)
- Lukina S.V. and Zhuikovb D.V., (2021). Monitoring of the contents of manganese, zinc, and copper in soils and plants of the central chernozemic region of Russia, *Eurasian Soil Science*, Vol. 54, No. 1, pp. 63–71. ISSN 1064-2293
- Madhavi G. and Chakraborty A.P., (2016). Application of eggshell as fertilizer and calcium supplement tablet. *International Journal of Innovative Research in Science, Engineering and Technology*, 5: 3520-3525
- Ok Y.S., Lee S.S., Jeon W.T., Oh S.E., Usman A.R., Moon D.H. (2011): Application of eggshell waste for the immobilization of cadmium and lead in a contaminated soil. *Environmental geochemistry and health*, 33: 31–39.
- Owuamanam S., Soleimani M., Cree D.E., (2021). Fabrication and Characterization of Bio-Epoxy Eggshell Composites. *Applied Mechanics*, 2, 694–713.
- Park J.A. and Sohn S.H., (2018). The influence of hen aging on eggshell ultrastructure and shell mineral components, *Korean J Food Science Animal Resources*; 38(5): 1080–91.
- Radhika Y, Sriram M & Aarti T. (2020). Egg shell powder as an unusual food ingredient for calcium fortification, *Food and Agriculture Spectrum Journal*. 1: 3.
- Ray S., Barman A.K, Pradip Kumar Roy and Bipin Kumar Singh, (2017). Chicken eggshell powder as dietary calcium source in chocolate cakes, *The Pharma Innovation Journal*; 6(9): 01-04;
- Santos W.O., Maria de Aquino P., Cuesta R.L., Saldanha I.M., Mattiello E.M., and Vergütz L., (2019). Zinc Diffusion and Availability Affected by Different Sources in Soils of Contrasting Textures, *Journal of Agricultural Science*; Vol. 11, No. 5; ISSN 1916-9752 E-ISSN 1916-9760
- Schaafsma A., Pakan I., Hofstede G.J.H., Muskiet F.A.J., Van Der Veer E., De Vries P.J.F., (2000). Mineral, Amino Acid, and Hormonal Composition of Chicken Eggshell Powder and the Evaluation of Its Use in Human Nutrition. *Poult. Sci.*, 79, 1833–1838.
- Senbayram M., Gransee A., Wahle V. and Heike T., (2015). Role of magnesium fertilizers in agriculture: plant–soil continuum, *Crop and Pasture Science* 2015, 66(12) 1219-1229
- Soetan K.O., Olaiya C.O. and Oyewole O.E., (2010). The importance of mineral elements for humans, domestic animals and plants: A review, *African Journal of Food Science* Vol. 4(5) pp. 200-222.
- Takáč P., Szabová T., Kozáková L., Benková M., (2009). Heavy metals and their bioavailability from soils in the long-term polluted Central Spiš region of SR, *PLANT SOIL ENVIRON.*, 55, (4): 167–172.

- Vu N.T., Dinh T.H., Tran A.T., Le T.T.C., Vu T.T.H., Nguyen T.T.T., Pham T.A., Vu N.L., Koji S., Hama S., Kim I.I.S., Jang D.C. and Kime D.H., (2022). Eggshell powder as calcium source on growth and yield of groundnut (*Arachis hypogaea* L.), *Plant Production Science*
- Wijaya V. T and Teo S.S, (2019). Evaluation of eggshell as organic fertilizer on sweet basil, *International Journal of Sustainable Agricultural Research* Vol. 6, No. 2, pp. 79-86, ISSN(e): 2312-6477, ISSN(p): 2313-0393.
- Zulkeflee W., Chompoorat P., Siva R., (2020). Physicochemical and sensory properties of bread added with chicken eggshell powder, *Malaysian Journal of Analytical Sciences*, Vol 24 No 6: 873 – 881.



## AGRICULTURAL ROBOTS FOR THE FIELD APPLICATIONS

Vladimir PEJAKOVIĆ\*, Andreas GRONAUER

\*E-mail of corresponding author: vladimir.pejakovic@boku.ac.at

*Institute of Agricultural Engineering, Department of Sustainable Agricultural Systems, University of Natural Resources and Life Sciences, Peter-Jordan-Straße 82, Vienna, Austria*

### ABSTRACT

*In order to fulfill the constantly increasing food demands by the year 2050, (expected world population is projected to reach number of 9.3 billion), food production has to be increased roughly for 60%, compared to the current numbers. It should also be mentioned that the availability of agricultural land almost reached its limits, which imposes necessity for changes in conventional food production processes in order to reach projected goals. Furthermore, conventional food production is mostly based on the principles of Agriculture 3.0 which implies implementation of the large quantities of chemical products, e.g., fertilizers and pesticides. Since the environmental regulations are constantly getting tighter, an overall tendency is in decreasing of use of above-mentioned products. Also, constant increase in energy costs e.g., diesel, electric energy, and deficiency in skilled human labor presents significant problem when we talk about modern day agricultural production. One of the possible solutions to avoid above mentioned drawbacks on the one side, as well as to increase production yield is implementation of modern technologies, e.g., (internet of things) IoT, robotics, (artificial intelligence) AI, etc. in agriculture. This novel approach is called smart farming. In this review paper we will give a brief overview of existing applications of robotic systems in agricultural field applications as well as retrospective towards the research trends in the field of robotics. Furthermore, it should be mentioned that beside the fact that the initial costs for robotic platform are significant task when acquisition of such equipment is discussed, agricultural robot platforms imposed itself as a critical piece of agricultural equipment for performing of repetitive tasks cheaper, faster and more accurate than human labor.*

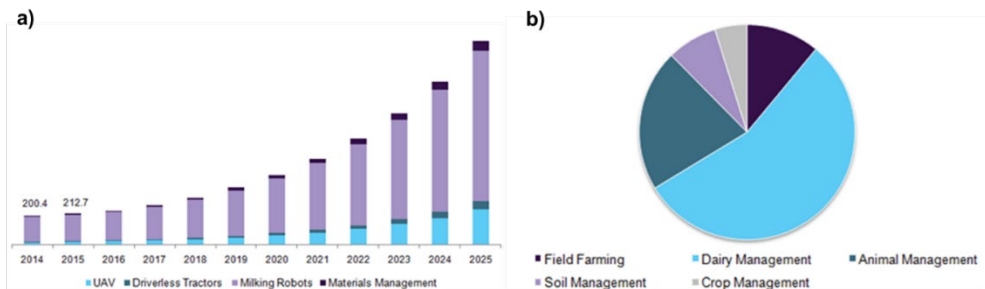
**Keywords:** *Smart farming, IoT, robotics, AI, agricultural robots*

## INTRODUCTION

As it is already known, Earth's population in 2020s has already reached the number of 8 billion, with the further estimated increase until the year 2050 of 20%, which leads to the total number of 9.3 billion. Such a tremendous increase in world's population inevitably leads to the increase in demands for the food production (estimated food production capacity in 2050 is 60% more than the current food production) (United Nations, 2017). Additionally, global urbanization trends in the last decades led to the increase in migration from the rural towards urban environments. Some predictions claim that by the year of 2050, 2/3 of the overall population is going to live in urban environments. Furthermore, it should be mentioned that available agricultural land has already reaching its limits, with modest capability for the further increase by the year of 2050.

Traditionally, agricultural food production is a production process which heavily depends on the human labor. In modern times, this fact becomes additional obstacle in the food production chain, for both, poor countries (where existing production processes are not providing enough capacity to feed increasing population) as well as rich ones (where agricultural production is not such a favorable profession for the young people which are choosing other, more profitable ones). Furthermore, traditional agriculture is heavily based on the implementation of chemical treatment of crops (e.g., using of pesticides, herbicides and fertilizers) in order to maximize the yield and profit. Since excessive use of above-mentioned chemical treatments presents environmental hazard and can cause pollution of the air, soil and water, its usage should be decreased to the absolute minimum (Zhang et al., 2018).

One of the possible solutions which could resolve above mentioned problems is application of the precision agriculture principles. By its definition, precision agriculture means application of appropriate measures when and where needed. In order to achieve that, the whole set of new approaches and technologies, e.g., information and communication technologies, implementation of artificial intelligence and agricultural robotics are used. Theoretically, this should inevitably lead to the boost in the yields and profit, while minimizing production costs, e.g., decrease in human labor, (especially the qualified one), energy, usage of water, fertilizers, pesticides and other agrochemicals (McBratney et al., 2005).



**Figure 1** U.S. agricultural robot market (2015 – 2025) (Market Analysis Report, 2021)

If we observe the time period from 2015 – 2025, referring to the trends on the U.S. agricultural market, we can notice clearly visible trend in the increase of investments in precision agriculture (PA) technologies, roughly segmented into the unmanned aerial vehicles (UAV), milking robots, driverless robots and materials management (see Figure 1 a).

Implementation of above-mentioned tools, which was simultaneously related to the increase in development of the IoT technologies significantly helped farmers to optimize their food production chains by minimizing the production costs (energy savings, labor savings and savings in fertilizers, pesticides, water and herbicides), while simultaneously increasing productivity. As it can be seen (see Figure 1 b), mostly affected processes were field farming, soil, crop and dairy managements. While the automatic milking systems were the most dominant product on the market, predictions says that in the following time period driverless tractors and agricultural robots will exhibit significant growth. If we observe things on the global level, at the beginning of the observation period 2015 – 2025, the most influential market was North American, sharing around 32% of world market, with high adaptability and willingness to adopt new technologies. Significant share takes Europe, as well as Asian Pacific region (Market Analysis Report, 2021).

As it can be seen, precision agriculture as a novel, technology-based approach already gives significant results on the global level, with tremendous potential which yet has to be achieved in the following years. Having in mind the size and complexity of PA approaches in food production chain, we have decided to focus our investigation of the current status of the research and market solutions in the field of agricultural robotics.

## **AGRICULTURAL ROBOTS**

A wide variety of different agricultural robots and research approaches was a subject of interest over the past years. In general, we have to take into account that development of robotic applications in agriculture is from technological standpoint very complex process due to the fact that the working environment is unstructured and prone to the fast changes in time and space. Furthermore, robots have to be capable to handle different types of natural objects, e.g., fruits and leaves with high variability in size, shape, texture, color, etc. Last, but not the least, agricultural robots have to be capable to perform its tasks in the presence of unpredictable situations (Oliveira et al., 2020). Having in mind such a complex task, creation of one generic system capable to operate with many types of crops and in different environments, while not neglecting safety issues, is challenging and difficult.

In general, agricultural robots could be mainly sorted as devices for: land preparation, sowing/planting, plant treatment, pest control and harvesting (Oliveira et al., 2020).

### ***Agricultural robots for land preparation***

Land preparation is one of the first tasks which has to be done before planting the proper culture into the field. Mostly, in land preparation the first step is to perform the ploughing of the soil, fertilization, or both together (Sistler, 1987). In order to increase productivity, and to decrease stress from the farmer/tractor operator, several solutions has been offered. First one, is to perform these (plowing) or similar operations in automated steering mode (Zhang et al., 2010). Usually, new tractors are already sold with integrated systems for automated steering, while older tractors could be retrofitted with automated steering kits. Although, automation in the steering process can take off the load from the farmer (e.g., while plowing), further

automation of the agricultural production, where full elimination of the driver was the next step. Overall, in development of fully autonomous solutions, two main concepts could be recognized, and they are: heavy – duty autonomous tractors and smaller autonomous agricultural robots (Zhang et al., 2010).

Heavy – duty autonomous tractor concept, e.g., Case IH Magnum Autonomous Concept presents the way how to integrate fully autonomous agricultural machine into already existing fleet of vehicles on the farms (Case IH 2016). In this approach, fully autonomous, tractor size vehicle can work autonomously in the field with the set of conventional tractor implements, e.g., plows, without the operator presence. Additionally, option of machine coupling where simultaneously in the field will be tractor with operator and one/several autonomous tractors which will be fulfilling their tasks automatically, is provided as well.



**Figure 2** Case IH Magnum Autonomous Concept heavy duty tractor (Case IH 2016)

The main advantage of above-mentioned concept is that it allows integration of autonomous unmanned heavy-duty tractor into existing fleet without previous pre adaptation of farm or the field. Furthermore, usage of conventional tractor implements, e.g., plows, cultivators, fertilizer, sprayers is possible since there is no conceptual difference in production process except elimination of operator from machine.

Another approach is development of smaller autonomous robotic vehicles which would perform the various set of tasks in the field, among which ones is the plowing as well. The main advantage of these vehicles lying in their size. Since they are smaller and significantly lighter, comparing to the conventional tractors, soil compaction is in general avoided. Intensive work in the field of development of autonomous robotic vehicles for agricultural tasks has been summarized throughout several review articles (Oliveira et al., 2021, Botta et al., 2022). The main concern for the researches was development of precisely controlled system which would allow it to perform wide variety of the tasks in the field, e.g., plowing, seeding, fertilizing, etc. Typical representatives of this group of autonomous robotic vehicles are commercially available Cäsar robot (Raussendorf GmbH, 2017), or ICS20 (AutoAgri, 2021).

Both of the robots are relatively small in size, which allows them easy manipulation in the field and simultaneous operation with humans. Both of them are capable fulfilling of several tasks with simple implementation of different implements via 3-point connection.

Overall, the main task for this group of agricultural robot vehicles is to fulfill satisfying accuracy in autonomous navigation mode.





**Figure 3** Cäsar robot (Raussendorf GmbH, 2017) and ICS 20 robot (AutoAgri, 2021)

Regardless of concept, common thing for all this group of autonomous vehicles is that performing of tasks automatically is performed throughout the use of real time kinematic (RTK) technology for global navigation satellite system (GNSS). With the use of RTK – GNSS satisfying precision up to 3 cm is achieved. Beside RTK – GNSS technology for navigation, robots are usually equipped with additional set of sensors for detection of obstacles, e.g., trees, rocks, etc. like ultrasonic sensors, LIDAR, etc (Oliveira et al., 2021, Botta et al., 2022).

#### *Agricultural robots for sowing/planting*

Sowing agricultural robots are favorable solutions since soil compaction due to the frequent passing of robot over the field is avoided, since its lighter mass comparing to the heavy-duty conventional tractors. Beside lower rate of the soil compaction, implementation of these type of vehicles allows us to maintain better aeration and water infiltration of the soil, which is promoted due to the better porosity. Wide variety of robots for seeding/sowing applications exists on the market, with typical representatives Di-Wheel robot from Australian centre for field robotics (Sukkarieh, 2017) and Xaver Sowing Robot (Fendt, 2020). Di – Wheel robot is two-wheel light robot platform prototype for seeding, weeding and spraying (Sukkarieh, 2017). For navigation it uses RTK – GNSS and can be retrofitted with several other types of sensors.



**Figure 4** Di-Wheel robot (Sukkarieh, 2017) and Xaver Sowing Robot (Fendt, 2020)

Xaver Sowing Robot are small size autonomous robots manufactured by Fendt, RTK – GNSS navigated, usually works alone or connected in the network with other robots (Fendt, 2020). Beside seeding, they are suitable for different types of operations like weeding, fertilizing, etc. Possibility to do the mapping of the field during the procedure of sowing

allows high autonomy later, especially during the weeding and fertilizing process, with the help of already pre-existing crop maps. As it was mentioned, effectiveness of the robot can be increased with implementation of the whole fleet of several robots. The whole fleet is connected to the cloud via 5G network where they can receive commands and send the reports. Each unit weights 250 kg loaded with seeds with working autonomy of 3.5 hours. Fleet of six robots can cover the area of 3 ha per hour. With lading station disposal at the field, whole fleet can perform round the clock, full autonomous duties.

### ***Agricultural robots for plant treatment***

Plant treatment, e.g., weeding is one of the most important tasks in traditional agricultural production, since the pests and diseases can cause significant losses in the yield (Oliveira et al., 2021). In order to perform losses, weeding imposes itself as a necessity. As well as in traditional agricultural approach, weeding can be divided into three main groups, mechanical, chemical and thermal (which further can be divided into laser or electrical discharge). Typical representatives of mechanical and chemical weeding agricultural robots are presented in Figure 5. Farm droid FD20 (Farm Droid, 2020) is one of the most famous commercially available agricultural robot platforms for universal purposes, which beside weeding can perform the sowing as well. During the weeding process, robot strongly relies on the crop maps generated during the seeding process, which significantly helps throughout the process of hoeing, where weeding hoe can approach to the plant to the distance of 6 mm, without the possibility to damage it. Field navigation is done via RTK – GNSS. Solar panels, and lithium-ion batteries allows round the clock field autonomy. AX-1 (Kilter) is ultra-precise spraying robot for chemical weeding (Kilter Systems, 2021). The platform is fully electrical, and navigate itself with the help of RTK – GNSS. Weed – crop detection is achieved with the help of RGB cameras and advanced algorithm. Light concept of the vehicle allows low soil compaction.



**Figure 5** Farm droid (Farm Droid, 2020) and Xaver Sowing Robot (Kilter Systems, 2021)

Other types of solutions, e.g., Small Robot Company electrical discharge prototype (Small Robot Company, 2019) or Carbon robotics laser weeding robot (Carbon Robotics, 2021) are solutions based on electrical/laser beam weed action. Navigation principle and weed detection based on RTK – GNSS and RGB camera detection as well, while the weed action mechanism is different.

### *Agricultural robots for harvesting*

As an agricultural task, harvesting often requires significant amount of time and human labor in order to collect the crops from the field. Some studies revealed that harvesting operations takes up to the 25% of overall time in agricultural working process (Hayashi et al., 2014). Furthermore, with nowadays labor costs as well as deficiency in seasonal workers, development of agricultural robots for harvesting tasks imposed itself as a necessity. Most of the researchers in the field of development of robots for the harvesting have faced problems which were mainly manifested throughout difficulties mainly related to navigation throughout the crop rows, detection of fruits and their detachment (Bac et al., 2014).



**Figure 6** Robotics plus kiwifruit picker (Robotics Plus, 2021) and AVL Compact S9000 asparagus harvester (AVL motion, 2021)

At Fig 6 (left) can be seen Robotics plus kiwifruit picker from New Zealand (Robotics Plus, 2021). Designed machine has capability to navigate itself throughout the orchard, select the fruit and pick it up from the tree. Due to its design, it is capable to operate autonomously or in synergy with the humans. Above mentioned solution presents just one approach how to decrease need for unqualified seasonal labor force. Fig 6 (right) represents AVL Compact S9000 asparagus harvester (AVL motion, 2021). This autonomous harvesting platform is designed to fully replace human labor in the harvesting process of asparagus. Device is operated by one operator and it can harvest up to 9 thousand asparagus per hour. Reserve battery kit allows full 24 h autonomy. With above mentioned device, on the size of average 10 ha, harvesting process is already profitable. Several other solutions for harvesting of different types of crops and fruits is already available on the market, and the work is summarized in several review articles (Oliveira et al., 2021, Botta et al., 2022). Most of those devices for harvesting is using RGB cameras to identify the crops, e.g., lettuce, strawberries, etc. and afterwards, when signal is processed robotic arm or similar tool is activated in order to perform the picking of the fruit.

### *Agricultural robots for Yield Estimation*

This specific group of agricultural robots is most commonly used periodically during the production cycle of the crop in order to estimate crop physiology and product quality. Mostly, this kind of applications are used in orchards and vineyards, but it could be used in field for observation of the overall quality of the crops, e.g., for detection of pest infection or the lack of fertilizer (Oliveira et al., 2021). These kinds of systems are either airborne UAV or land-

based robots. Common for all of them is presence of RGB camera, or other type of machine vision, e.g., LIDAR in order to detect the crop shape, and analyze its quality (Oliveira et al., 2021). P4 Multispectral (DJI) UAV is typical representative of plant monitoring (DJI, 2019). It is equipped with RGB camera and multispectral imaging sensors. Navigation is performed via RTK – GNSS system. Battery autonomy allows the flight time of roughly 30 minutes.



**Figure 7** P4 Multispectral (DJI) UAV (DJI, 2019) and Ara robot from EcoRobotix (right)

Typical representative of land – based agricultural robots for crop inspection is Ara robot from EcoRobotix which navigates itself throughout the crop lines with the help of the RTK – GNSS and RGB camera, while provides option for integration of different set of sensors (Eco Robotix, 2019). Several different types of sensors and techniques are used for this kind of applications, e.g., RGB cameras, near infra-red (NIR) sensors, infra-red (IR) sensors, ultrasonic sensors, fluorescence level detection sensor, etc.

## DISCUSSION AND CONCLUSIONS

As it was presented in the text above, agricultural robot design strongly depends from its original purpose, e.g., plowing, fertilizing, sowing, weeding, etc. On the base of the currently available solutions, no general comparison can be observed. Nevertheless, although the differences between different groups of the autonomous robotic vehicles exists, similarities can be seen in the principle of navigation and automatic steering. Most of above observed devices uses RTK – GNSS system for field navigation. Furthermore, group of autonomous robotic vehicles for weeding and for plant status monitoring as well for the orchards and the vineyards mostly share the common system of computer vision. Since development of IoT technologies is constant, further improvements of above-mentioned systems can be proposed in the field of sensorics, motion systems as well as in computer algorithms. For example, development of above-mentioned technologies already managed to allow increase in success rate of harvesting robots in last decade twice, compared to initial results [9-10]. Based on such example, it is to believe that in the following years development of agricultural autonomous robotic systems will continue in both, their efficiency as well as in the robustness.

## REFERENCES

- Auto Agri (2021). IC – S20 robot. <https://autoagri.no/products/>  
AVL motion (2021). AVL Compact S9000 asparagus harvester. <https://gbo.eu/portfolio/avl-motion/>

- Bac, C.W., Henten, E.J.V., Hemming, J., Edan, Y. (2014). Harvesting Robots for High-value Crops: State-of-the-art Review and Challenges Ahead. *J. Field Robot.*, 31.
- Botta, A., Cavallone, P., Baglieri, L., Colucci, G., Tagliavini, L., Quaglia, G. (2022). A Review of Robots, Perception, and Tasks in Precision Agriculture. *Applied Mechanics*, 3, (3), 830-854.
- Carbon Robotics (2021). Carbon robotics laser weeding robot. <https://carbonrobotics.com/>
- Case IH (2016). Autonomous Concept Vehicle. <https://www.caseih.com/northamerica/en-us/Pages/campaigns/autonomous-concept-vehicle.aspx>
- DJI (2019). P4 Multispectral UAV. [https://enterprise-insights.dji.com/blog/all-about-p4-multispectral?utm\\_source=youtube&utm\\_medium=video&utm\\_campaign=intro](https://enterprise-insights.dji.com/blog/all-about-p4-multispectral?utm_source=youtube&utm_medium=video&utm_campaign=intro)
- Eco Robotix (2019). Ara robot. <https://ecorobotix.com/en/>
- Farm Droid (2020). Farm Droid FD20. <https://farmdroid.dk/en/product/>
- Fendt (2020). Project Xaver, Fendt Future Farm. <https://www.fendt.com/int/xaver>
- Hayashi, S., Yamamoto, S., Saito, S., Ochiai, Y., Kamata, J., Kurita, M., Yamamoto, K. (2014). Field Operation of a Movable Strawberry-harvesting Robot using a Travel Platform. *Jpn Agric. Res. Q*, 48, 307–316.
- Kilter Systems (2021). Kilter AX – 1 robot. <https://www.kiltersystems.com/>
- Market Analysis Report (2021). Agricultural Robots Market Size, Share & Trends Analysis Report By Product (UAV, Driverless Tractor, Milking Robots, Materials Management), By Application, By Region, And Segment Forecasts, 2018 – 2025. <https://www.grandviewresearch.com/industry-analysis/agricultural-robots-market>
- McBratney, A., Whelan, B., Anecev, T., Bouma, J. (2005). Future Directions of Precision Agriculture. *Precision Agriculture*, 6, 7–23.
- Oliveira, L.F.P., Moreira, A.P., Silva, M.F. (2021). Advances in Agriculture Robotics: A State-of-the-Art Review and Challenges Ahead. *Robotics*, 10, 2, 52. <https://doi.org/10.3390/robotics10020052>
- Oliveira, L.F.P., Silva, M.F., Moreira, A.P. (2020). Agricultural Robotics: A State-of-the-Art Survey. In Proceedings of the 23rd International Conference on Climbing and Walking Robots and the Support Technologies for Mobile Machines, 279–286.
- Raussendorf GmbH (2017). Cäsar Fruit robot. [https://www.raussendorf.de/pdf/raussendorf\\_obstroboter\\_02.pdf](https://www.raussendorf.de/pdf/raussendorf_obstroboter_02.pdf)
- Robotics Plus (2021). Robotics plus kiwifruit picker. <https://www.roboticsplus.co.nz/news/fruits-of-robotics/>
- Sistler, F. (1987) Robotics and intelligent machines in agriculture. *IEEE Journal on Robotics and Automation*, 3, 3 - 6.
- Small Robot Company (2019). Small Robot Company electrical discharge prototype. <https://www.smallrobotcompany.com/press-releases/2019/12/5/aq9n8o8vim9av1v875n1q4vn1ntijw>
- Sukkarieh, S. (2017). Mobile on-farm digital technology for smallholder farmers. In Proceedings of the Crawford Fund Annual Conference on Transforming Lives and Livelihoods: The Digital Revolution in Agriculture, 9–16.
- United Nations (2017). World Population Projected to Reach 9.8 Billion in 2050. <https://www.un.org/development/desa/en/news/population/world-population-prospects-2017.html>
- Zhang, X., Davidson, E.A. (2018). Improving Nitrogen and Water Management in Crop Production on a National Scale. *AGU Fall Meeting Abstracts*, Volume 1, 1–2.
- Zhang, X., Geimer, M., Noack, P.O., Grandl, L. (2010). A semi-autonomous tractor in an intelligent master – slave vehicle system. *Intelligent Service Robotics*, Volume 3, Issue 4, 263–269.

---

---



## NEW SYSTEM OF MANUFACTURING MOLDS USING INDUSTRY 4.0 FOR PELLETS AND BRIQUETTES

Larisa Georgiana MATEI<sup>1</sup>, Andrei-Alin VOINESCU<sup>1</sup>, Alexandru SUCIU<sup>1</sup>, Narcis GHITA<sup>2</sup>,  
Marius FATU<sup>2</sup>, Gabriel GARBAN<sup>2</sup>, Titus SLAVICI<sup>1\*</sup>

\*E-mail of the corresponding author: titusslavici@yahoo.com

<sup>1</sup>Politehnica University of Timisoara, Romania

<sup>2</sup>Ioan Slavici University, Romania

### ABSTRACT

*Industry 4.0 offers increased value compared to previous manufacturing generations. The development of smart products requires advanced technologies, both for conception and manufacturing. This creates a paradigm shift from economies of scale based on the operational lever to agile manufacturing. The goal of this research is to improve manufacturing processes and their key performance indicators. The aim of the paper is to introduce new systems that will have an impact on the production of the mold pellet, which will start from the 3D model of the mold. This will be made in a CAD program. Then, a system like cloud manufacturing will be used. It will provide all the information from the CAD modeling through the CAM procedure. This will create mold. Reverse engineering is used to improve mold design. Subsequently, cloud manufacturing will be used with analytics technology for all the information that the mold will give, aiming at a shorter problem resolution time. Introducing cloud manufacturing in the process enables the centralization of all the information. Also, it makes the process scalable. The technology is intended for concrete impact, in Industry 4.0 fashion: productivity, data processing, industrial connectivity, predictive engineering, and sustainability. It will also be a step ahead in the digitalization of all resources that are needed to implement a production system.*

*The main focus was on optimizing the manufacturing and product design of molds for pellets and briquettes using new technologies cloud manufacturing, cyber manufacturing, reverse engineering, and industry 4.0. The contributions of our work include four aspects. First, we expect to reduce the time of work by introducing the cloud manufacturing system and simplifying the production of pellets and briquettes mold. Second, we propose to optimize the errors that appear in the process by using cyber manufacturing. Third, we aim to save and make time more efficient in reproducing an old piece without a 3D Model and*

*to adjust an old piece from the machine with new features. Fourth, we present a solution for the detection of future issues and solving them in time.*

**Keywords:** *Cloud manufacturing, Cyber manufacturing, Reverse Engineering, Industry 4.0*

## INTRODUCTION

The main objective of this study is to find a more efficient way toward the optimization of the manufacturing and product design of a mold for pellets and briquets, using new technologies like cyber manufacturing, cloud, reverse engineering, and industry 4.0.

The aim of our paper is to introduce new systems that will have an impact on the production of the molds for pellets. The study starts from the 3D model of a mold, made in a CAD program. Through a cloud manufacturing system, the information from the CAD modeling is provided towards the CAM procedure to create the mold. Further, during cloud manufacturing, the information that received from the molding process will be analyzed and used to solve possible problems.

The results described in the paper are applied to the production of heating pellets, which are obtained in our factory at Cenei following certain scientifically proved rules (Untaru et al, 2014, Maris S. et al, 2017).

By introducing cloud manufacturing in the process (Zhang et al, 2014, Singh et al, 2021), we will be able to centralize all the information also will make the process to be scalable because it will be the main pilon for the growth of products and duction and centralize data between machines or even facilities for long-term strategic analysis.

Reverse engineering (Husted, 2021) helps to study some old machine parts that were used a long time ago the older pieces from the entire process, and make them even better and easy to produce.

Cyber manufacturing is a transformative system that translates data from the interconnected system into predictive and prescriptive operations to achieve resilient performance (Lee et al, 2016, Maris S.A. et al, 2017).

The impact of Industry 4.0 (Kagermann, 2017) gives a positive answer to the questions about productivity, data processing, industrial connectivity, predictive engineering and sustainability. It will also be a step ahead in the digitalization of all resources that are in need to implement a production system (Cozmiuc and Petrisor, 2018). „Industry 4.0 thus represents the new wave in the technological evolution of production, stimulating more and more companies to meet the new standards set by a constantly changing market, by transforming production units into "smart factories"” (Wang et al, 2016).

## MATERIALS AND METHODS

### *Theoretical aspects*

This research studies the use of cyber manufacturing, cloud manufacturing, reverse engineering, and industry 4.0 (Jamwal et al, 2021) and their role in the optimization of the manufacturing and product design of molds for the pellets and briquets process.



From what is already known (Anwer and Mathieu, 2016), production means the creation of a new concept that will revolutionize the present situation in production.

Economic profitability and time management are determined by the optimal use of the four techniques above mentioned.

The modern manufacturing industry is exposed to high competitiveness at a global scale and largely variable demands, which negatively affect manufacturing resource efficiency.

### ***Constructive solutions that are already in use in our factory***

#### ***Quick Die Exchange System – QDES.60 (Figure 1)***

The Quick Die Exchange System shortens the time to exchange the die - below one hour. QDES.60 is a system of rapid centering and clamping of the die to the rotary shaft. It is realized by means of four fixed centering jaws that fix the position of the die axis with the axis of the rotary shaft and the front plane of the rotary shaft perpendicular to the axis of the rotating shaft.

Using the technique above a new design for replacing the die roll is obtained, using a hydraulic system that will simplify the replacement/changing. This system is implemented and studied at a pellet factory at Cenei Industrial Park.

The die is released from the jaws through the hydraulic pump in a few seconds, after unscrewing only a dozen or so fastening screws. QDES.60 allows to disassemble the hot die, while maintaining appropriate security measures, without losing time often associated with the need to at least partially cool it down.



**Figure 1** Die Exchange System – QDES.60 (Cenei Industrial Park)

Sensors and parameters monitored automatically within this system are:

- belt slip sensor,
- temperature sensor of roller bearings,
- temperature sensor of the main bearing of the rotating shaft,
- central lubrication sensor,
- temperature sensor of the raw material,
- pellets temperature sensor,
- lack of feed sensor, below the rollers,
- temperature sensor of bearings of main engines,
- optional sensor of the moment of pressing force of the rolls to the die.

### *Central Automatic Lubrication System – CALS (Figure 2)*

Central Automatic Lubrication System relieves operators with the arduous duty to ensure that the pelleting unit is properly protected with grease. It is built of a progressive valve and a high-pressure hose system (stainless steel) that feeds grease to the roller bearings, the rotating shaft raw material temperature at the discharge from the conditioner, pellets temperature at the discharge from the pellet mill's chamber, and pneumatic system pressure. The panel allows control of the rotation left / right, Start / Stop conditioner, granulator stop, worm feeder control, and steam/water control.

CALS is controlled by a central controller with a suitably designed program and allows a high level of automatic work control.

The pellet mill and all machines are equipped with a full set of sensors that continuously monitor the status of individual subunits in the line.



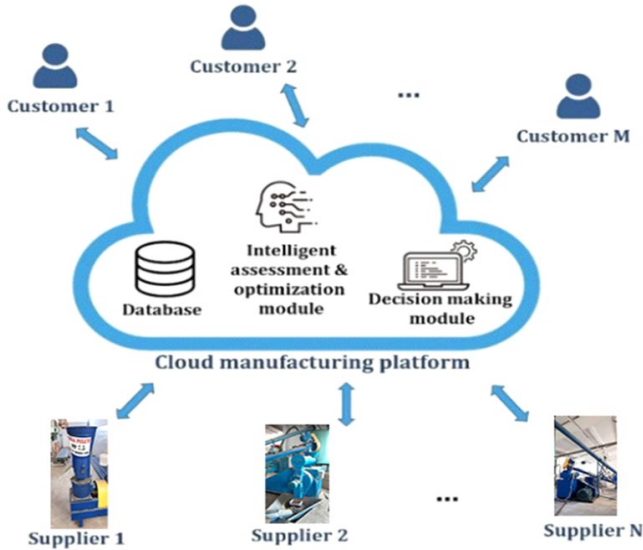
**Figure 2** Central Automatic Lubrication System – CALS (Cenei Industrial Park)

### ***New directions and paradigms in manufacturing***

Further we will refer to four main paradigms and directions in modern manufacturing that were applied for the modernization and optimization of our existing technological line at Cenei: Cloud manufacturing, Cyber manufacturing, Reverse Engineering, Industry 4.0

*Cloud manufacturing*

The modern manufacturing industry is exposed to high competitiveness at a global scale and largely variable demands, which negatively affect manufacturing resource efficiency.



**Figure 3** Cloud manufacturing framework for product design of mold (Simeone et al., 2019)

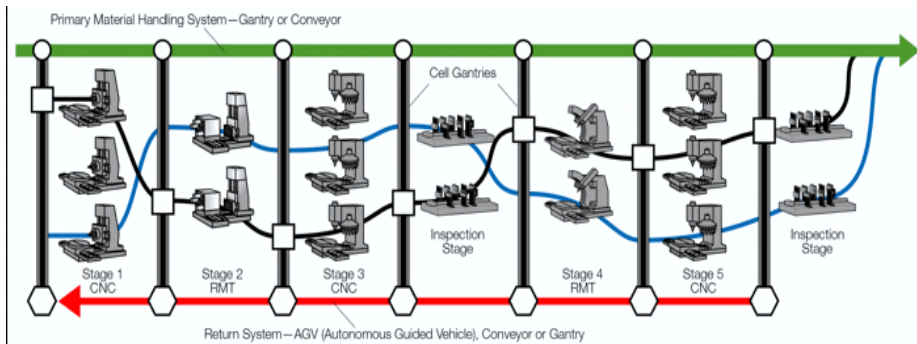
Cloud manufacturing is emerging as a new manufacturing paradigm as well as an integrated technology, which is promising in transforming today’s manufacturing industry towards service-oriented, highly collaborative, and innovative manufacturing in the future. An application case of a private cloud manufacturing system for a conglomerate is presented (Singh et al, 2021).

The cloud platform collects the manufacturing services requests from customers and offers from suppliers and processes them via intelligent decision-making algorithms to find the best manufacturing solution according to the user’s needs.

*Cyber manufacturing*

Cyber manufacturing is a transformative concept that involves the translation of data from interconnected systems into predictive and prescriptive operations to achieve resilient performance. It intertwines industrial big data and smart analytics to discover and comprehend invisible issues for decision-making. This paper introduces a fundamental framework and architecture for cyber manufacturing systems (Lee et al, 2016).

Cyber manufacturing evolved from e-manufacturing, which is a systematic methodology that enables manufacturing operations to successfully integrate with the functional objectives of an enterprise through the use of tether-free (i.e., internet, wireless technologies, web, etc.) communication and predictive technologies.



**Figure 4** Scheme of how Cyber Manufacturing is working (Lee et al, 2016)

### *Reverse Engineering*

Reverse engineering is needed to acquire knowledge of design that is lost, obsolete, or withheld. Techniques have evolved from manual measurements to utilizing the possibilities that lie within 3D scanning technologies. (Helle and Lemu, 2021).

Reverse engineering in manufacturing and engineering is used for a wide variety of reasons. By taking apart engineering equipment or a manufactured product and discovering the materials it is made from and how it works, we can help a business determine and improve production processes, enhance product effectiveness, and protect patents.

To remain competitive, the industry is continually searching for new methods to evolve its products. This need is addressed by introducing a new reverse engineering, redesign methodology, formulating the customer needs, followed by reverse engineering, creating a functional model through teardowns. The functional model leads to specifications that match the customer's needs.

Reverse engineering has become the answer for industrial manufacturers seeking cost savings.

### *Industry 4.0*

The Industry 4.0 proposal is considered a revolution in the industry, based on cyber-physical systems, and the fourth such revolution in history. This revolution succeeds in the first industrial revolution, steam (1700 – 1860); assembly line (1870-1969); automation (1969-2020). Industry 4.0 is scheduled from 2020 onwards (Kagermann, 2017).

Industry 4.0 was proposed and adopted as part of the German Government's high-tech strategy action plan for 2020. The key promoters of Industry 4.0 are the Industrie 4.0 working group and Plattform Industrie 4.0. They describe the Industry 4.0 vision, the inherent basic technologies, and scenarios for its implementation (Kagermann, 2017).

## **RESULTS AND DISCUSSION**

### *Cloud Manufacturing*

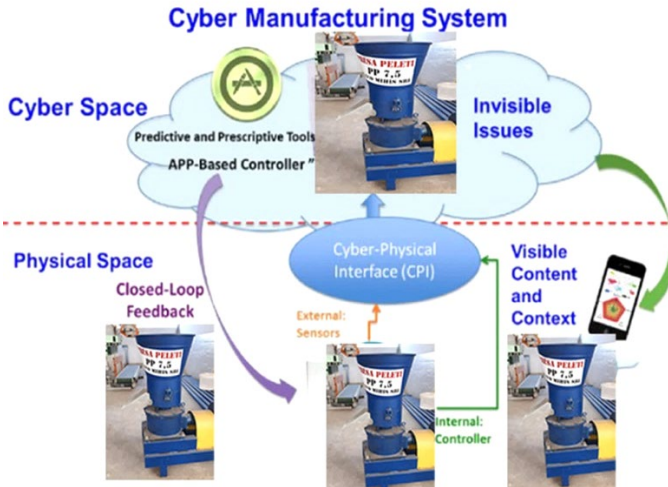
It is mandatory that the equipment should be supervised by a technician which is near the devices. However, by applying the cloud manufacturing technique it is a step in the future to process automation, it will be a resource-saving, a time saving and increase productivity.

By introducing cloud manufacturing in the process of production, the information will be easier to centralize, and the process will become scalable because it will be the main pilon for the growth of the production, centralizing data between machines or even facilities for long-term strategic analysis.

If in normal situations, the process will need 2 h of work just in by a physical man, after automation it will require the same 2 h of work on the entire process but without the need to be there.

**Cyber Manufacturing**

In this situation, a virtual copy of the real production process is made, in order to support the life cycle of products. This approach enables the control system to compensate and responsible personnel to intervene at the right time on the right assets. It allows having an idea of the time movement, all types of costs of the production line, and how much the production consumes of the finished goods, by doing that, will allow optimizing the production process permanently.



**Figure 5** Cyber Manufacturing system (Lee et al, 2016)

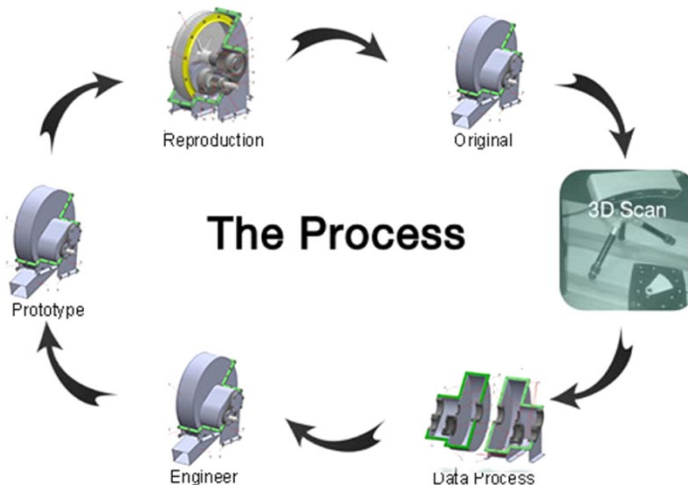
A big first step will be about the configuration of the product line in the plant that will have a big impact on a scalable situation in the plant, but also about the efficiency between cycles.

**Reverse Engineering**

The goal is to create a copy of the mold so it can be adapted to all kinds of dimensions of pelletizing machines.

In the current case, the design proposed by Yuan and Chen (2014) will be used as starting point. The drawings with 5 holes of 6 mm diameter will be constrained such that the head of the machine will have a 10 mm or 30 mm diameter hole. The machine will be thus adapted to that diameter.

This approach makes the following situation become feasible: the mold and machinery currently built in a remote location (e.g., Oradea, at approximately 180 km from the factory in Cenei) can be reverse-engineered and built, based on its virtual copy in a more affordable location (e.g., Timisoara, which is at approximately 30 km from the factory in Cenei). Thus, time and money can be saved.



**Figure 6** Reverse Engineering (Helle and Lemu, 2021)

Also, using reverse engineering helps studying some old parts that were used a long time ago of the mold or pieces from the entire process and make them even better and easy to produce.

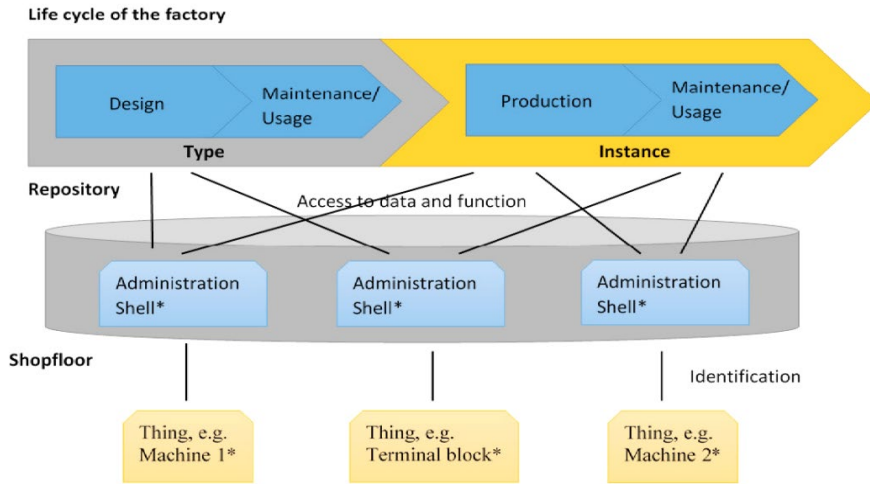
### ***Industry 4.0***

Industry 4.0 offers increased flexibility, mass customization, and individualization, increased speed, improved quality, increased productivity, and allows companies to face various challenges such as increasingly individualized products, shortened time to market, and high product quality (Zheng et al, 2018).

Industry 4.0 makes it possible to gather and analyze data across machines, enabling faster, more flexible, and more efficient processes to produce higher-quality goods at reduced costs.

At the factory in Cenei, a technician must load the shredder with the material to be pelletized (or briquetted).

All the on-site human interaction presumes to load the shredder with raw material (e.g., straw) and to unload the pellets / briquettes from the packing device. After that, all the production process is automatized, by using sensors and intelligent production planning: filling the silos with shredded raw material, connecting and disconnecting the mill, achieving required humidity for the raw material, mixing 2 materials in a given mass ratio, etc. Optimal humidity for pelletization (around 10%) is achieved either by spraying water or by passing the raw material through a dryer.



**Figure 7** Life cycle of a factory (Zheng et al, 2018)

## CONCLUSIONS

This paper presents four applications of an integrated cyber-physical system for cloud manufacturing. The developed functionalities for remote monitoring and control, distributed process planning, model-guided remote assembly, and active collision avoidance for human-robot collaboration can be wrapped as cloud services. Future work will include function improvement, testing, and embedding the four strategies into assembly plans so that the behavior of a robot matches the nature of a task for seamless human-robot collaborative assembly.

All benefits that are obtained by using cyber manufacturing, cloud manufacturing, reverse engineering, and industry 4.0 have an impact on improvement in the entire area of plant production and manufacturing of the optimizing of the production and design of a mold for pellets and briquettes.

The most important contribution of the paper is the opportunity of using new technologies like these four that are presented in this paper that have an impact on scalable manufacturing, manufacturing schedule duration, and costs that are needed to manufacture molds for pellets and briquettes.

## REFERENCES

- Anwer, N. & Mathieu, L. (2016). From reverse engineering to shape engineering in mechanical design. *CIRP Annals*, 65(1), 165-168.
- Cozmiuc, D., & Petrisor, I. (2018). Industrie 4.0 by siemens: steps made next. *Journal of Cases on Information Technology (JCIT)*, 20(1), 31-45.
- Helle, R. H., & Lemu, H. G. (2021). A case study on use of 3D scanning for reverse engineering and quality control. *Materials Today: Proceedings*, 45, 5255-5262.

- Husted, E. (2021). Reverse Engineering. *Quality*, 60(3), 44-46.
- Jamwal, A., Agrawal, R., Sharma, M. & Giallanza, A. (2021). Industry 4.0 technologies for manufacturing sustainability: a systematic review and future research directions. *Applied Sciences*, 11(12), 5725.
- Kagermann, H. (2017). Chancen von Industrie 4.0 nutzen. In *Handbuch Industrie 4.0 Bd. 4*. Springer Vieweg, Berlin, Heidelberg. 237-248..
- Lee, J., Bagheri, B., & Jin, C. (2016). Introduction to cyber manufacturing. *Manufacturing Letters*, 8, 11-15.
- Maris, S., Slavici, T., Nenu, P., and Baciu, L. (2017). Artificial intelligence as a decision-making tool in planning the research. *Broad Research in Artificial Intelligence and Neuroscience*, 8(3), 69-76
- Maris, S. A., Tucu, D., Banabatsas, T., Nagy, V., Maris, S., & Nenu, P. F. (2017). Possibilities of using the robots in greenhouses. In *Proceedings of the 45th International Symposium on Agricultural Engineering, Actual Tasks on Agricultural Engineering, 21-24 February 2017, Opatija, Croatia*, 531-537
- Simeone, A., Caggiano, A., Boun, L., & Deng, B. (2019). Intelligent cloud manufacturing platform for efficient resource sharing in smart manufacturing networks. *Procedia Cirp*, 79, 233-238.
- Singh, R., Gehlot, A., Akram, S.V., Gupta, L.R., Jena, M.K., Prakash, C., Singh, S. and Kumar, R. (2021). Cloud manufacturing, internet of things-assisted manufacturing and 3D printing technology: reliable tools for sustainable construction. *Sustainability*, 13(13), 7327.
- Untaru, M., Rotarescu, V., & Dorneanu, L. (2012). Artificial Neural Networks for sustainable agribusiness: a case study of five energetic crops. *Agrociencia*, 46(5), 507-518.
- Wang, S., Wan, J., Li, D., & Zhang, C. (2016). Implementing smart factory of industrie 4.0: an outlook. *International journal of distributed sensor networks*, 12(1), 3159805.
- Yuan, X., & Chen, Z (2014). Design of Q450 pellet molding machine and force analysis of its molding assembly based on Solidworks. *School of Technology*
- Zhang, L., Luo, Y., Tao, F., Li, B.H., Ren, L., Zhang, X., Guo, H., Cheng, Y., Hu, A. and Liu, Y. (2014). Cloud manufacturing: a new manufacturing paradigm. *Enterprise Information Systems*, 8(2), 167-187.
- Zheng, P., Sang, Z., Zhong, R.Y., Liu, Y., Liu, C., Mubarak, K., Yu, S. and Xu, X. (2018). Smart manufacturing systems for Industry 4.0: Conceptual framework, scenarios, and future perspectives. *Frontiers of Mechanical Engineering*, 13(2), 137-150.





## APPLICATION OF MACHINE LEARNING MODELS IN MISCANTHUS X GIGANTEUS YIELD ESTIMATION

Ivan BRANDIĆ<sup>1</sup>, Neven VOĆA<sup>1</sup>, Josip LETO<sup>2</sup>, Nikola BILANDŽIJA<sup>3\*</sup>

\*E-mail of corresponding author: nbilanzija@agr.hr

<sup>1</sup>Department of Agricultural Technology, Storage and Transport, University of Zagreb,  
Faculty of Agriculture, Svetošimunska cesta 25, Croatia

<sup>2</sup>Department of Field Crops, Forage and Grassland, University of Zagreb,  
Faculty of Agriculture, Svetošimunska cesta 25, Croatia

<sup>3</sup>Department of Agricultural Engineering, University of Zagreb, Faculty of Agriculture,  
Svetošimunska cesta 25, Croatia

### ABSTRACT

*Miscanthus x giganteus (MxG) is a perennial crop that has high potential for energy production due to its favorable physical and chemical properties and high yield per unit area. To accelerate the process of yield estimation of MxG based on different input parameters, there is a possibility to apply different forms of nonlinear models such as polynomials, artificial neural networks (ANN), support vector machine (SVM) and random forest regression (RFR). In this paper, the aforementioned models were developed in order to predict the yield of Mxg per unit area with respect to the input parameters of plant height and number of shoots. The statistical analysis "goodness of fit" performed, showed high performance in the evaluation; the coefficient of determination ( $R^2$ ) was used as the main parameter for the effectiveness of the models. Nonlinear models in the form of polynomials ( $R^2=0.69$ ), SVM ( $R^2=0.65$ ), RFR ( $R^2=0.60$ ) and ANN ( $R^2=0.66$ ) can estimate biomass yield MxG with satisfactory accuracy.*

**Keywords:** *Miscanthus x Giganteus, Machine Learning, Yield estimation, Artificial Intelligence.*

### INTRODUCTION

Given the increase in global population and the impact on the economy, creating a sustainable form of energy production and consumption is one of the most important energy problems (Zhong et al., 2019). Among the fundamental challenges facing today's mankind are, on the one hand, negative climate changes and on the other hand, the transition from current energy sources to renewable energy (Vanegas Cantarero, 2020). The European Union

is increasingly promoting the use of biomass as a renewable energy source to increase independence from current conventional energy sources (Bilandžija et al., 2020). MxG as an energy crop has been recognized as a good substitute for existing fossil fuels in recent years in terms of energy production (Chen et al., 2016). In addition to the many advantages of using MxG as a permanent crop for biomass production, harvesting can occur throughout the growing season (Bilandžija et al., 2017).

Existing linear models for estimating and predicting yields are flawed due to the inability to generalize the data. Machine learning (ML) techniques such as ANN, RFR, and SVM are increasingly used in diagnostics and data processing (Han et al., 2018). The main goal of ML is to develop an algorithm or software that can learn based on past experience according to the principle of human action in learning. To reach a satisfactory threshold of "intelligence," it is necessary to learn from previously collected data, determine the function, generalize, determine the direction of dimensionality, and give context to the data (Holzinger, 2017). The RFR model algorithms are considered a successful tool in the regression method and can be used in a wide range of generalization and prediction. They are based on the integration of multiple decision trees, where the final solution is achieved by the method of "voting" (Han et al., 2018) (Biau and Scornet, 2016). Models in the form of ANN and SVM based on defined datasets are advanced methods for evaluation (Zhong et al., 2019).

Considering all this, the aim of this work is to develop ML and nonlinear models in the form of higher degree polynomials, ANN, RFR and SVM to predict biomass yield MxG with respect to the input parameters number of shoots and plant height.

## MATERIALS AND METHODS

The variables used to develop the model for the purpose of prediction included the input data plant height and number of shoots, while the output data were the biomass yield values of MxG. In the paper, a total of 16 samples from different plots over 2 vegetation years (32 MxG samples in total) were analysed. After determining the dataset, it is divided into a part for learning and testing the model in the ratio of 70% and 30%. In the statistical analysis, the analysed data were presented in the form of means and standard deviations. Analysis of variance (ANOVA) and Tukey's HSD test were used to compare the samples to determine the differences between the observed variables in relation to the growing season of MxG. In addition to statistical analysis, samples were sized separately for each year using principal component analysis (PCA) to determine the behaviour of a single sample in relation to the observed variables. Models in the form of polynomials, SVM, RFR, ANN were used as regression models in a supervised form of learning. As a supervised form of learning, SVM models are based on statistical learning theories where the desired output is calculated using the following equation (García Nieto et al., 2019, Zendehboudi et al., 2018):

$$\gamma = \omega^T \theta(\chi) + b$$

Where  $w$  is the weight vector,  $b$  is the threshold and  $\theta$  is the non-linear function of the model.

RFR models can predict the desired output parameter with good accuracy, with the individual calculation of each decision tree calculating the entropy (Schonlau and Zou, 2020):

$$E = - \sum_{i=1}^c p_i \times \log(p_i)$$

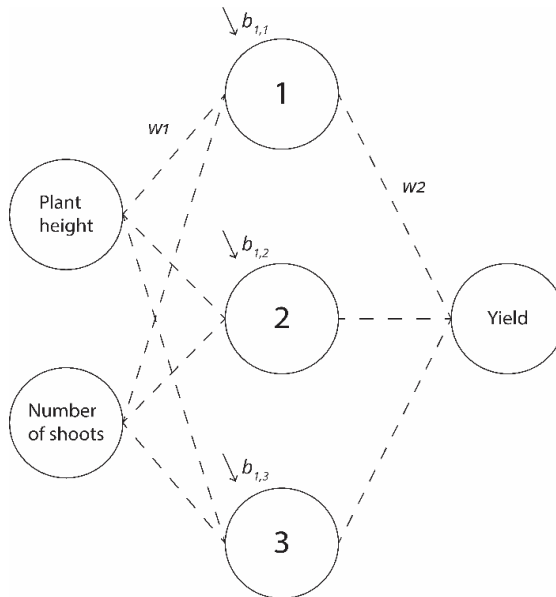
Here  $c$  stands for the class number,  $p_i$  for the probability of the input value of each class.

To calculate the output value (in this case the biomass yield of MxG) with the ANN model, it is necessary to set the weighting coefficients and biases. The output layer of ANN model is calculated according to the following equation (Voća et al., 2021):

$$Y = f_1(W_2 \cdot f_2(W_1 \cdot X + B_1) + B_2)$$

Where  $Y$  stands for the output value,  $f$  for the functions in the hidden and output layers,  $W$  for the weighting coefficient and  $B$  for the threshold value.

Figure 1 shows the developed ANN model for predicting MxG biomass yield, which consists of 2 neurons in the input layer, 3 in the hidden layer and 1 in the output layer.



**Figure 1** Structure of developed 2-3-1 ANN

In order to show the ability of the developed models in predicting the yield of miscanthus biomass, it is necessary to perform certain statistical tests. Statistically calculated "Goodness of fit" parameters give values; reduced chi-square ( $\chi^2$ ), root mean square error (RMSE), coefficient of determination ( $R^2$ ), mean bias error (MBE), mean percentage error (MPE) and sum of square error (SSE) (Arsenović et al., 2015).

## RESULTS AND DISCUSSION

Table 1 shows the data on plant height, number of shoots and yield of MxG.

**Table 1** Statistical analysis of MxG properties

Year	Plant height (m)	Number of shoots/m <sup>2</sup>	Yield (DM t ha <sup>-1</sup> )
2019.	2.73±0.37 <sup>a</sup>	80.11±7.54 <sup>b</sup>	39.09±5.26 <sup>b</sup>
2020.	3.56±0.15 <sup>b</sup>	72.38±10.22 <sup>a</sup>	28.23±5.08 <sup>a</sup>
Statistical significance	*	**	*

The means in the same column (various samples), with different lowercase superscripts, are statistically different ( $p < 0.05$ ), according to Tukey's HSD test. Statistical significance; \*  $p \leq 0.01$ ; \*\*  $p \leq 0.05$ .

Table 1 shows statistical analysis performed which determined the means and standard deviations of the variables plant height, number of shoots, and yield of MxG for the 2019 and 2020 vegetation years. The mean value of plant height was 2.73 m in 2019., while the next year was 3.56 m. The difference between the observed values determined by analysis of variance (ANOVA) is statistically significant at  $p \leq 0.01$ . The number of shoots also differed with respect to different year. In 2019, the average number of shoots was 80.11/m<sup>2</sup>, while the next year the average was 72.38/m<sup>2</sup>, the observed MxG samples are statistically significant at  $p \leq 0.05$ . The average yield value in 2019 was 39.09 (t ha<sup>-1</sup>), while the value for 2020 is significantly different at  $p \leq 0.01$  (28.23 t ha<sup>-1</sup>).

Principal component analysis (PCA) is a commonly used visualization technique designed to simplify the display of a larger data set (by finding patterns) with minimal loss of display (Beattie & Esmonde-White, 2021). The data on MxG (Table 2 and 3), obtained using PCA, are shown in Figure 2 and Figure 3 for each sample in relation to the year of cultivation, showing the direction of movement of each sample in relation to the variables of plant height, number of shoots, and yield.

Figure 2 shows the data of the basic characteristics of MxG in the 2019 growing season.

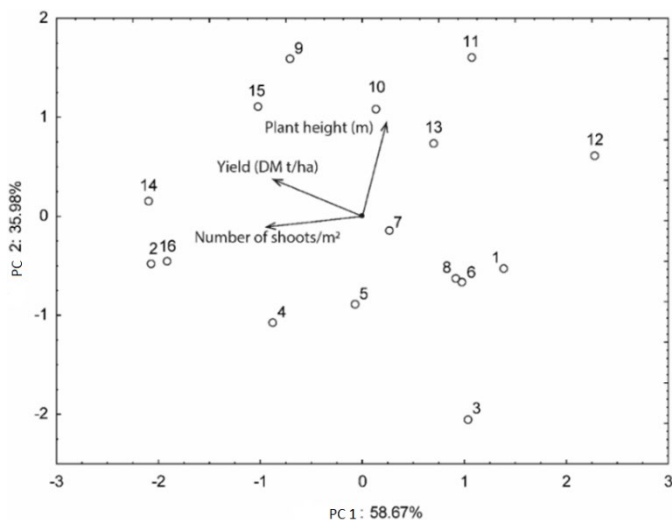
**Figure 2** PCA of observed data of MxG in 2019. growing season

Figure 2 shows the plant height, number of shoots and yield of MxG in the 2019 growing season. Samples from 16 different plots show mutual differences. Sample 3 has the lowest stem height, while sample 11 has the highest. The number of shoots/m<sup>2</sup> is lowest in sample 12, while it is highest in sample 14. The biomass yield (tonnes dry matter per hectare unit) is lowest in sample 3, while it is highest in sample 2.

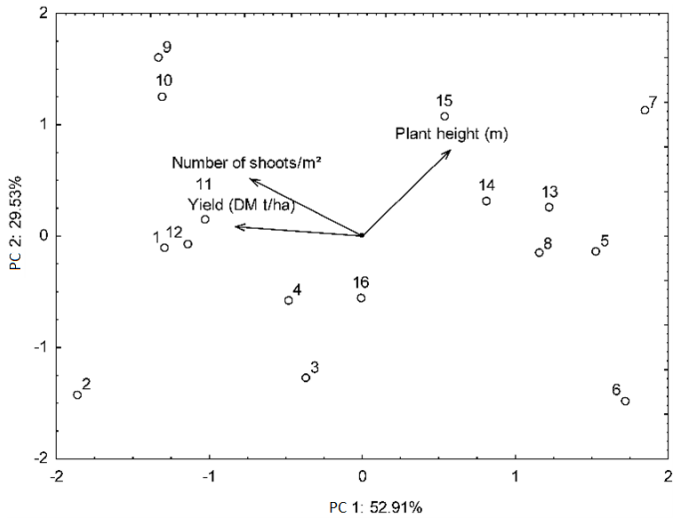
Table 2 shows data on the basic properties of MxG.

**Table 2** basic properties of MxG (2019. growing season)

Sample	Plant height (m)	Number of shoots/m <sup>2</sup>	Yield (DM t ha <sup>-1</sup> )
1	2.62	72.0	33.83
2	2.37	89.5	46.96
3	2.11	76.4	31.34
4	2.26	83.7	41.45
5	2.42	81.1	37.71
6	2.64	78.4	32.32
7	2.69	78.6	38.02
8	2.58	75.7	34.66
9	3.17	80.5	46.09
10	3.18	81.4	38.78
11	3.40	75.2	36.93
12	3.06	66.0	33.06
13	2.97	73.1	39.78
14	2.73	95.1	44.33
15	3.00	83.1	45.96
16	2.47	91.9	44.26

Table 2 shows the values of plant height, number of shoots and yield of 16 observed samples of MxG biomass in 2019 vegetation year. Using the values from the table, the numerical values shown in Figure 2 are simplified. Figure 3 shows the PCA of the observed MxG samples in relation to the variables; plant height, number of shoots and yield in the vegetation year 2020.

Figure 3 shows the plant height, number of shoots and yield of MxG in the 2020 growing season. The samples from 16 different plots show mutual differences. Sample 2 has the lowest plant height, while sample 7 has the highest. The number of shoots/m<sup>2</sup> is lowest in sample 6, while it is highest in sample 9. The biomass yield (tonnes dry matter per hectare unit) is lowest in sample 5, while it is highest in sample 2.



**Figure 3** PCA of observed data of MxG in 2020. growing season

Table 3 shows data on the basic characteristics of MxG in 2020. growing season.

Table 3 basic properties of MxG (2020. growing season)

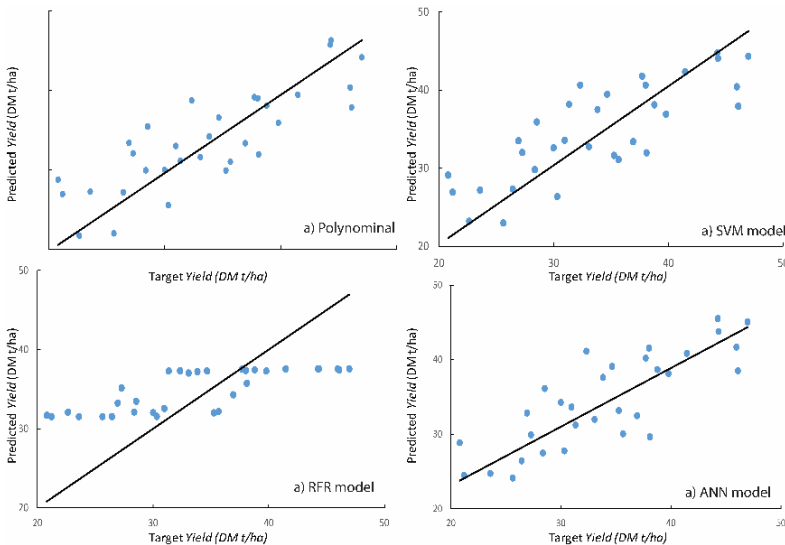
Sample	Plant height (m)	Number of shoots/m2	Yield (DM t/ha)
1	3.41	86.00	28.53
2	3.31	68.67	38.09
3	3.35	70.00	27.27
4	3.42	76.33	26.93
5	3.62	65.33	21.20
6	3.50	52.33	22.63
7	3.86	62.67	25.62
8	3.61	65.67	23.59
9	3.62	95.00	29.99
10	3.65	84.00	35.26
11	3.49	80.67	30.96
12	3.51	73.00	35.66
13	3.63	72.00	20.81
14	3.66	68.00	26.43
15	3.77	69.67	30.31
16	3.49	68.67	28.36

Table 4 shows the performance of the developed models, calculated with the statistical test "goodness of fit".

**Table 4** „Goodness of fit“ of developed models

Model	$\chi^2$	RMSE	MBE	MPE	SSE	AARD	R <sup>2</sup>	Skew	Kurt	SD	Var
Polynom	17.72	4.14	0.00	10.86	549.26	185.86	0.69	-0,10	-0,70	0,00	4,21
SVM	20.91	4.50	-0.99	12.16	617.10	214.95	0.65	0,12	-0,84	-0,99	4,46
RFR	34.35	5.77	-1.19	16.34	1019.55	309.66	0.60	0,20	-0,87	-1,19	5,73
ANN	20.72	4.48	-0.22	11.43	640.69	172.17	0.66	0,17	-0,18	-0,22	4,55

The parameters that ensure the performance of the developed models for yield prediction in terms of number of shoots and plant height parameters of the developed models are shown in Table 4. For the developed model in the form of polynomial, the values of  $\chi^2$  (17.72), RMSE (4.14), MBE (0.00), SSE (549.26), AARD (185.86) and R<sup>2</sup> (0.69) show a satisfactory predictive ability of the model. For the developed SVM and RFR model values of  $\chi^2$  (20.91 and 34.35), RMSE (4.50 and 5.77), MBE (-0.99 and -1.19), MPE (12.16 and 16.34), SSE (617.10 and 1019.55), AARD (214.95 and 309.66) and R<sup>2</sup> (0.65 and 0.60) show a slightly lower ability in prediction. For ANN model calculated parameters show for for  $\chi^2$  (20.72), RMSE (4.48), MBE -0.22), MPE (11.43), SSE (640.69), AARD (172.17) and R<sup>2</sup> (0.66), which proves that the developed model. Of all the developed models, Polynomials shows the best results.



**Figure 4** Target vs. Predicted Yield (DM t/ha) for a) Polynominal, b) SVM model, c) RFR model and d) ANN model

Figure 4 shows the target yield compared to the predicted yield for the models developed. As can be seen, the data on the Y and X axes overlap to a large extent, showing that the developed models are suitable for predicting the yield of biomass MxG. The coefficient of determination ( $R^2$ ) was taken as the main parameter for the predictive ability of the model and is 0.69 for the polynomial model, 0.65 for the SVM model, 0.60 for the RFR model and 0.66 for the ANN model. Of the 4 models developed, ANN has the smallest yield estimation error.

## CONCLUSION

MxG is a perennial grass, which is characterized by a high yield per unit area and a great potential in the possibility of converting it into useful energy. One of the most important characteristics of MxG is the amount of biomass produced per unit area. In this research, 4 non-linear models were developed using which the yield was estimated based on the input values of plant height and number of shoots. The coefficient of determination ( $R^2$ ) was taken as the main statistical parameter for assessing the ability of the developed models for prediction, which in the case of the developed models in the form of polynomials (0.69), SVM (0.65), RFR (0.60) and ANN (0.66). Model in form of polynomials showed a best performance in the estimation of MxG Yield.

## REFERENCES

- Arsenović, M.; Pezo, L.; Stanković, S.; Radojević, Z. Factor space differentiation of brick clays according to mineral content: Prediction of final brick product quality. *Appl. Clay Sci.* 2015, 115, 108–114.
- Beattie, J. R., & Esmonde-White, F. W. L. (2021). Exploration of Principal Component Analysis: Deriving Principal Component Analysis Visually Using Spectra. *Applied Spectroscopy*, 75(4), 361–375. <https://doi.org/10.1177/0003702820987847>
- Biau, G., & Scornet, E. (2016). A random forest guided tour. *Test*, 25(2), 197–227. <https://doi.org/10.1007/s11749-016-0481-7>
- Bilandžija, N., Jurisic, V., Voca, N., Leto, J., Matin, A., Sito, S., & Kricka, T. (2017). Combustion properties of *Miscanthus x giganteus* biomass – Optimization of harvest time. *Journal of the Energy Institute*, 90(4), 528–533. <https://doi.org/10.1016/j.joei.2016.05.009>
- Bilandžija, N., Fabijanić, G., Sito, S., Grubor, M., Krononc, Z., Čopec, K., & Kovačev, I. (2020). Harvest systems of *miscanthus x giganteus* biomass: A review. *Journal of Central European Agriculture*, 21(1), 159–167. <https://doi.org/10.5513/JCEA01/21.1.2511>
- Chen, M. H., Bowman, M. J., Cotta, M. A., Dien, B. S., Iten, L. B., Whitehead, T. R., Rausch, K. D., Tumbleson, M. E., & Singh, V. (2016). *Miscanthus x giganteus* xylooligosaccharides: Purification and fermentation. *Carbohydrate Polymers*, 140, 96–103. <https://doi.org/10.1016/j.carbpol.2015.12.052>
- García Nieto, P. J., García-Gonzalo, E., Sánchez Lasheras, F., Paredes-Sánchez, J. P., & Riesgo Fernández, P. (2019). Forecast of the higher heating value in biomass torrefaction by means of machine learning techniques. *Journal of Computational and Applied Mathematics*, 357, 284–301. <https://doi.org/10.1016/j.cam.2019.03.009>
- Han, T., Jiang, D., Zhao, Q., Wang, L., & Yin, K. (2018). Comparison of random forest, artificial neural networks and support vector machine for intelligent diagnosis of rotating machinery. *Transactions of the Institute of Measurement and Control*, 40(8), 2681–2693. <https://doi.org/10.1177/0142331217708242>



- Holzinger, A. (2017). Introduction to MACHine Learning & Knowledge Extraction (MAKE). *Machine Learning and Knowledge Extraction*, 1(1), 1–20. <https://doi.org/10.3390/make1010001>
- Schonlau, M.; Zou, R. Y. The random forest algorithm for statistical learning. *Stata Journal*, 2020, 20(1), 3–29. <https://doi.org/10.1177/1536867X20909688>
- Vanegas Cantarero, M. M. (2020). Of renewable energy, energy democracy, and sustainable development: A roadmap to accelerate the energy transition in developing countries. *Energy Research and Social Science*, 70(July), 101716. <https://doi.org/10.1016/j.erss.2020.101716>
- Voca, N.; Pezo, L.; Peter, A.; Suput, D.; Loncar, B.; Kricka, T. Modelling of corn kernel pre-treatment, drying and processing for ethanol production using artificial neural networks. *Ind. Crop. Prod.* 2021, 162, 113293. <https://doi.org/10.1016/j.indcrop.2021.113293>.
- Zendehboudi, A., Baseer, M. A., & Saidur, R. (2018). Application of support vector machine models for forecasting solar and wind energy resources: A review. *Journal of Cleaner Production*, 199, 272–285. <https://doi.org/10.1016/j.jclepro.2018.07.164>
- Zhong, H., Wang, J., Jia, H., Mu, Y., & Lv, S. (2019). Vector field-based support vector regression for building energy consumption prediction. *Applied Energy*, 242(March 2019), 403–414. <https://doi.org/10.1016/j.apenergy.2019.03.078>

---

---



## TECHNOLOGICAL INNOVATIONS AND NEW APPROACHES IN AGRICULTURAL PRODUCTION

Ante GALIĆ<sup>1\*</sup>, Stjepan PLIESTIĆ<sup>1</sup>

\*E-mail of corresponding author: agalic@agr.hr

*University of Zagreb Faculty of Agriculture, Department of agricultural technology, storage and transportation*

### ABSTRACT

*Increasing global competition, steady population growth on the one hand, and, paradoxically, labour shortages on the other, pose new challenges to agricultural producers. These are the main reasons for the growing interest in technological innovations and new approaches to agricultural production. Digital technologies are transforming agriculture due to their ubiquity, portability and mobility, and can therefore be used in a variety of ways to improve inefficiencies in the production, processing, storage and transportation of agricultural products. It is also important to mention that digitalization, and especially automation or robotization, requires high investments that ultimately represent a financial burden per unit of product. Therefore, it is important to find the optimal equipment level in terms of quantity, quality and price of the final product. Technologies such as sensors, communication networks, artificial intelligence, blockchain, high-performance computing, the Internet of Things, the 5G network, robotics, and advanced machines are already improving access to information, inputs, and markets, increasing production and productivity, streamlining supply chains, and reducing operating costs. Each of these technologies brings some value, from data collection to management and control. By using these technologies, it has become possible to get an overview of the entire company in just a few clicks, so that decisions are no longer made based solely on experience and tradition, but in real time based on analysed data. In addition to all the benefits offered by new technologies, there are also some challenges to overcome, such as: Cybersecurity and data protection, labour replacement and re-education, the risk of creating a digital divide between economies, sectors or individuals with differing abilities to adopt new technologies.*

**Keywords:** *agriculture, new technologies, digitization, automation, robotization*

## INTRODUCTION

As the human population grows, agricultural production should be doubled to meet food needs. Taking into account the limited agricultural land, water, and labour resources, the efficiency of agricultural production would have to be increased by an estimated 25% to meet the set goals. At the same time, the increasing environmental impacts of agricultural production and processing would need to be limited. These problems cannot be solved with current agricultural production, so a turnaround in agricultural production is needed to enable their solution. The survey conducted among farmers in the Republic of Croatia on the use of computers and digital technologies showed that 67.3% of respondents use them for administrative work, sales and record keeping. Only 15.8% of respondents use computers and digital technologies to improve production, processing and production control (Husnjak et al., 2021). Nowadays, technological innovations are making their way into agriculture, enabling higher yields with less use of resources and human labour (Biel et al., 2018). Digital transformation uses digital technologies to transform all aspects of business. Thus, technology stands for specific knowledge or equipment; digitalization is a process that focuses on technologies, while digital transformation focuses on the end user (Dlačić et al., 2018). The proliferation of mobile technologies, remote sensing services, and distributed computing is already improving smallholder farmers' access to information, inputs, and markets in the agri-food sector, increasing production and productivity, streamlining supply chains, and reducing operating costs. Technologies used in digital agriculture include sensors, communication networks, unmanned aerial systems (UAS), artificial intelligence (AI), blockchain, high-performance computing (HPC), 5G networks, robotics, and other advanced machines, often based on the principles of the Internet of Things (Yahya, 2018; Bill et al., 2012). According to the same authors, the use of these technological innovations should make agricultural production more profitable, more efficient, safer, and have a smaller environmental footprint. Each of these technologies adds value to agriculture, from data collection to management and processing to guidance and control. This integrated system provides new insights that improve the ability to make decisions and then implement them.

## OVERVIEW OF THE MAIN TECHNOLOGIES IMPACTING THE AGRI-FOOD VALUE CHAIN

According to the AGRI Committee research “Impacts of the digital economy on the food chain and the CAP” (2019), IoT, robotization, AI, and Big Data are expected to have the greatest impact in the near future; blockchain, GNSS, and virtual reality are expected to have medium impact; and broadband networks, ICT, and e-commerce platforms are expected to have low impact, as they are already highly established and considered crucial for future digitalization developments.

### *Internet of Things (IoT)*

For the successful functioning of precision agriculture, farm management or blockchain technology, the functioning of the IoT is necessary and therefore forms the basis for the implementation of the aforementioned technologies in agriculture. The IoT is defined as a paradigm according to which a large number of physical objects (“things”), will play an important role in the future development of technology with the help of computers and network connections. The structure of IoT consists of three layers: the sensor layer, the data

transmission layer, and the data storage and management layer. With the help of wireless network connection of various objects, these objects exchange the information they collect with the help of sensors. In case of excess information, it can be transferred to the cloud or to another networked device. In addition to sharing, the IoT also enables a collective review of all the information received from different systems in one place. In agriculture, by applying agronomic expertise and “smart” algorithms based on the data obtained, it is possible to provide an analysis of the current situation and forecasts that warn of potential threats. In addition to machine-to-machine (M2M) communication, the IoT system allows people to interact with devices, with people accessing all information through an Internet application or via a computer (Bartzanas et al., 2017; Biel et al., 2018). In practice, IoT technology is most commonly used in the following areas: integrated information management of products, devices, and goods, and in the management of logistics systems (Guangyu et al., 2013). The most commonly used technologies within the IoT system are RFID (Radio-frequency identification) and WSN (Wireless Sensor Network WSN or wireless sensors can be placed in the field, greenhouse, cold storage, or warehouse to monitor environmental conditions and transmit this data in real time to a management system (Guangyu et al., 2013). RFID technology enables non-contact identification and tracking of products, animals, supply chain and quality control, and the life cycle of agricultural products using RFID tags (Bartzanas et al., 2017). Sensors have become extremely important in agriculture to make the most accurate and precise decisions and optimize production. Sensors are used for monitoring and data collection and allow users to have better control and easier decision making. The main contribution of IoT is that different types of data generated at different points in the food chain can be combined and made available for a wide range of applications for different actors in and around the food chain. In the future, distributed and precise monitoring of plants will ensure optimal growing or living conditions for vegetables and animals, and autonomous systems will control production. Thanks to IoT, supply chains will be able to monitor every stage in the life of a product, react automatically in the event of a defective product, and increase consumers' sense of security through a transparent information system about the product life cycle.

### ***Automation and robotisation***

In the production and processing of agricultural products, and with the aim of increasing the added value of products, there is a growing interest in process automation and robotization of production lines. The introduction of automation and/or robotization requires high investments, which ultimately represent a financial burden per unit of product. Therefore, it is important to find the optimal level of automation and/or robotization equipment in relation to the quantity, quality and price of the final product. Depending on the level of automation and/or robotization, production lines for processing agricultural products can be divided into:

- lines for small farms (> from 100 kgh<sup>-1</sup>) - mostly manual or semi-automatic systems with minimal equipment and automation. These lines operate mainly on the control principle (open-loop control, command control), i.e. they execute routine instructions without human assistance, automatically start (begin) or repeat a given work cycle. In such systems, the application of a higher level of automation (control, management) is complex and requires significant financial investment.
- lines for medium-sized plants (> from 500 kgh<sup>-1</sup>) - mainly semi-automatic and automatic systems with minimal to medium equipment and automation. These lines

operate mainly on the principles of regulation (closed-loop, feedback, open-loop) or control (open-loop or automatic control).

- lines for large plants and/or industrial plants ( $> 1.500 \text{ kgh}^{-1}$ ) - mostly automatic systems with medium to high equipment and automation. These lines operate at the highest level of control: computer control or digital control (Computer Control) is a control system in which the control unit is a digital computer (computer). Intelligent control (Intelligent Control) is a control system that attempts to mimic the behavior of a human while driving. It is based on the methods of artificial intelligence (AI) and computational intelligence (CI).

According to the above classification and based on experience, only plants with capacity higher than  $500 \text{ kgh}^{-1}$  and with medium equipment and automation, depending on the type and nature of the raw material, can be considered profitable. In addition, the payback period and annual utilization of such production lines should also be considered. Global experience in this field shows that investments in such production lines are justified and competitive in the market. Therefore, it is considered that the investments are justified and thus competitive in the market if the production line is in operation for 8 to 12 months per year and the daily working time is 12 to 16 hours. From the above approach, i.e. the scale and justification of investments, it can be concluded that it is necessary to join larger organizational forms (cooperatives, limited liability companies, etc.) in the field of refining and processing of agricultural and food products (Husnjak et al., 2021).

### ***Artificial Intelligence (AI)***

AI refers to systems that exhibit intelligent behaviour by analysing their environment and performing various tasks - with some degree of autonomy - to achieve specific goals. AI-based systems can be purely software-based (e.g., search engines, voice and facial recognition) or embedded in hardware devices (e.g., advanced robots, autonomous cars, drones). Machine learning is a subfield of artificial intelligence and deep learning is a subfield of machine learning. Machine learning (ML) is defined as the scientific field that gives machines the ability to learn from “experience” (training data). The applications of ML in agricultural production systems can be categorised as follows:

- crop production (yield prediction, disease and weed detection, species identification),
- livestock management (animal welfare and livestock production),
- water and soil management.

In virtual assistants, the focus is on the artificial intelligence function. Using machine learning, virtual assistants understand language and communicate with users in a personalised way. In the future, virtual assistants could help farmers with advice or recommendations for specific problems on the farm.

One of the applications of deep learning (DL) in agriculture today is image recognition, but deep learning applications offer many other opportunities in smart agriculture, such as:

- information processing in agriculture,
- optimal control of agricultural production systems,
- intelligent agricultural machinery equipment, and
- management of agricultural economic systems.

### ***Traceability and Big Data***

Big Data refers to large amounts of data generated in a short period of time from a variety of different sources. Traceability and Big Data for agri-food chains use the following technologies or applications: Radio Frequency Identification (RFID), Wireless Sensor Networks (WSN), satellite and remote sensing devices, geographic information and satellite imagery, smart tags, quality sensors, sensor-based refrigeration, drones, and blockchain technology. Using these technologies and a backbone system (databases, servers, terminals connected via distributed computer networks), data from the production, storage, transportation, sales, and consumption stages of the food chain are extracted and combined into directly usable information for decision support systems.

The combined use of various radio frequency (RF) technologies and standards to improve supply chain management has been thoroughly researched and successfully applied in the agri-food sector. However, the development of a complete traceability system from the field to the end consumer's table is still at an early stage and many questions remain unanswered. Most of the research conducted shows that the proposed solutions are too invasive and therefore not accepted by operators. Some of the emerging solutions are the use of intelligent box pallets (IBP) and intelligent containers (IC). IBP and IC can be used in transportation processes to avoid unfavourable conditions in the transportation of perishable goods. They are equipped with technologies that make it possible to monitor the condition of goods “on-line” and independently change the settings during transportation. Changes in the condition of perishable agricultural products are communicated to the user through the application layer (middleware). Briefly, IBP and IC contain a wireless sensor network (WSN), a freight supervision unit (FSU) and a telematics gateway. The middleware provides the data of the IBP or IC to customers via a customer defined data interface. This allows customers to integrate data from the IBP and/or IC into their own IT systems. This also allows using the information provided by the IBP and/or IC to be used along the entire supply chain. For continuous monitoring of the entire supply chain, an offline concept had to be developed. For this concept the wireless sensor nodes have to be integrated in the perishable goods, e. g. sensor nodes in boxes or on a pallet. During transport or storage processes that are not connected to the load unit (FSU), the sensors must be able to log the relevant data offline. When a FSU is available these sensor nodes have to be switched to the regular online mode. A software installed on PC, smartphone, or tablet and the FSU enable configuring the sensor nodes when scanning is performed. The program package includes all applicable standards for recording, specifying, and tracking products.

The cost of implementing new technologies is significant and is a barrier to widespread adoption. Although most solutions known to date are based solely on the use of RFID tags, the price of the tag is still too high to justify its use in packaging of cheaper fresh products ( $\approx$  1-2 €/pack). Special attention must be paid to the selection of the tag to be used, as such tags must be used in critical conditions, especially in humid environments that absorb RF energy.

Overall, IBPs and/or ICs can increase the transparency of the agri-food (cold) supply chain by enabling traceability and providing information about the shelf life of each load and its physical condition. Furthermore, with the detailed information about the quality of perishable goods, new logistics processes can be developed to increase the efficiency of logistics for perishable goods and thus reduce food waste (Dittmer et al., 2012, Pliestić et al., 2017).

### ***Blockchain***

One technology that is becoming increasingly popular in agriculture and has the potential to enable business transparency and product traceability is blockchain technology. Blockchain represents a structure of digital information that is shared between all nodes within the system but is owned by no one (Lamešić et al., 2019). The nodes are computers that randomly connect to each other, enabling the existence of a decentralized network (Navadkar et al., 2018). Applying blockchain technology to commodity traceability sounds abstract to farmers, but the concept is actually quite simple. Blockchain is a registry of transactions shared by all parties over the internet. Ongoing transactions are grouped into blocks that are appended to the previous block after verification. Each block is cryptographically linked to the previous one and is given a unique timestamp that cannot be changed later. If someone tries to tamper with their copy of the ledger within the system, they will be rejected by the other nodes in the system because this data does not match the other data (Devčić, 2019). The blockchain system works on the peer-to-peer (P2P) model, which means that all partners have equal rights and there is no central authority. The application of such a system, which uses the IoT to record all product-related information and store and lock it in the blockchain, allows users to transparently monitor the traceability of the product they purchase. In this sense, the consumer knows what he is buying and the farmer gets transparency that helps him avoid the need for further advertising. The problem that arises in the application of such a system is the disorganization of farms and the desire for fast money. A certain part of farmers does not see any benefit in such a system, as it does not allow them to explicitly increase the price of their products. In the future, product traceability will be able to achieve its full functionality through the application of the IoT, or the transmission of information in real time to all networked devices in combination with the blockchain, which does not allow changes to this information. Apart from the fact that users themselves will be able to track the entire life cycle of the product, the main problem of agriculture will be solved for the producers themselves, namely purchasing. Buyers will not be able to set prices themselves, but the quality system will evaluate the product, after which the price will be set. In this sense, the blockchain cancels the advantage of the buyer, as it is a decentralized system in which all information is available to everyone at the same time (Lamešić et al., 2019). In this context, the farmer has advantages over the current system, as the quality system evaluates his product and the purchase price is formed accordingly.

### ***Global Navigation Satellite System***

Global Navigation Satellite System (GNSS) refers to a constellation of satellites that provide signals from space that transmit position and time data to GNSS receivers. The receivers then use this data to determine location. Today, GNSS applications in agriculture are used for: agricultural machinery control, automatic steering, variable rate application, yield monitoring, biomass monitoring, soil condition monitoring, livestock tracking and virtual fencing, forest management, agricultural machinery monitoring and asset management, field definition, etc. Precision agriculture is beginning to develop with the integration of navigation satellites (GNSS) and geographic information systems (GIS) into agriculture. The goal of precision agriculture is to identify and provide the optimal growing conditions for each crop and, based on this, to accurately estimate the amount of fertilizer and protection needed. In this sense, precision agriculture enables timely performance of agricultural operations, high productivity, reduced number of operations, lower labor costs,



and reduced use of agrochemicals (Jurišić et al., 2015). According to Bill et al. (2012), the application of GIS and GNSS in agriculture can be divided into three categories:

- system for managing data on agronomy and field condition,
- supporting tool for carrying out work in the field,
- information source for easier decision making and implementation.

The first step in precision agriculture begins with data collection. Nowadays, information about natural conditions is increasingly presented in a digital cartographic record. With GIS, it is possible to combine database operations (search, queries, statistical analysis, etc.) with visual geographic (spatial) analysis based on mapped representations. Using GIS, the input data is simplified and the output data required by the user is obtained in real time. In addition to displaying the current situation, it is also possible to project certain spatial trends into the future that are important for agriculture. GPS and automatic control enable safe and precise cultivation of all parts of the soil, but also facilitate the physical work of the farmer. For seeding, precision agriculture allows the farmer to know exactly how much seed is needed in a given location, rather than just an average for a given area. In fertilization, it is possible to apply a variable dose of fertilizer, using a plan and maps to determine in advance the exact amount of individual fertilizer needed for each part of a plot. Each of these applications allows for less use of resources (agrochemicals, seeds, fuel, etc.) and the acquisition of precise information, ultimately resulting in lower financial investment costs, less physical labor, and higher yields.

### ***Virtual Reality***

Virtual reality (VR) is an artificial, computer-generated simulation or replica of a real environment or situation. In agriculture, technology from VR provides a closer look at crops without having to go into the fields. Using a 360-degree camera on a drone and a VR headset, farmers can take virtual tours of their fields (e.g., to inspect them for diseases and other problems). Another potential application in the agri-food sector could be the introduction of new sales services. On a virtual farm, customers can shop directly and select what they want to buy.

### ***Broadband networks***

Broadband Internet refers to Internet access that connects users to high-speed Internet. Broadband coverage in rural areas remains significantly lower than at the national level. For example, approximately 92.4% of rural households in the EU are covered by fixed lines, compared to 97.4% of households overall. For emerging wireless IoT applications to be successful, high-speed broadband networks such as 5G will certainly be needed.

### ***Information and Computer Technologies***

Information and communications technology (ICT) refers to activities or studies that involve computers and other electronic technologies. ICT is used as an umbrella term that encompasses all information and communication technologies including devices, networks, mobile applications, and others. They range from innovative technologies such as IoT and sensors to other existing technologies such as radio and satellites.

### ***Platforms for e-business***

Nowadays, platforms for e-business are hardly accepted in the agri-food sector. This may be due to internal factors (such as: low technological competence, size of the organisation,

perceived advantages, target market segment addressed, and type of products or services traded) and external factors (such as: competition, market trends, trust and control within the supply chain).

## **BARRIERS TO ADOPTION OF DIGITAL TECHNOLOGIES**

As digital agriculture develops, it will be critical to make the technology available to as many farmers as possible and to implement it in a way that minimises the negative impact on those working in the sector. The main barriers to the adoption of digital technologies are classified as follows:

- Data and intellectual property - the main problem is the protection of data and intellectual property rights. Closed platforms and data (instead of open source technologies and open data) can lead to economic barriers that prevent competition and hold back the development of markets.
- Employment impacts - implementation of digital agriculture could lead to high labour intensity and economic disruption in the labour market.
- Security - farming systems could present some uncertainties by increasing the possibility of large-scale, coordinated agricultural warfare. For example, hacking of agricultural control systems could lead to intentional damage to crop growth, contamination of feed and water supplies, and manipulation of data, all of which can be used for a common goal of damaging crop yields and reducing food availability.
- Case for change - some concrete examples of the use of digital technologies in growing common crops are not yet common, making it difficult to develop business cases that demonstrate the benefits of using these technologies. While this trend is changing, it may result in growers not being ready to adopt new technologies in a timely manner.
- High price tag - the initial cost of adopting digital technologies at scale in agriculture could be high and, for some farmers, a challenge that could take years to overcome. In this context, the size of the farm plays a crucial role. Thus, it can be assumed that there is a certain threshold of farm size above which it is financially worthwhile to invest in such technologies and above which it is still too risky or unnecessary. Moreover, in addition to finances, information deficits and the existence of a part of farmers who resist modern technologies are obstacles.

However, in addition to the farmers themselves, a major obstacle is the disorganisation of agriculture itself, which, due to a number of problems, hinders the development of agriculture and makes it impossible to develop some kind of plan for applying technologies to a larger number of farmers.

## **CONCLUSION**

When it comes to technological innovations, it is difficult to group all technologies under one term because not all technologies have the same goal and not all technologies are suitable for all users. Some technologies, such as automation, robotics, navigation, and weather stations, are already of great use to farmers. But these technologies rarely work independently. In most cases, the combination of these technologies results in a farm management system and precision agriculture based on it. On the other hand, most of these technologies gain their full functionality through the use of the Internet of Things and blockchain technology. In

addition to the obstacles that need to be overcome, we can point out the main benefits of digitalization in agriculture:

- the management of resources throughout the system can be highly optimized and individualized,
- the combination of advanced data science, sensors and ubiquitous connectivity enables farmers to gain real insights in real time,
- the ability to collect and use large amounts of important data at minimal cost,
- crops and livestock can be managed exactly to their own optimal specifications,
- farmers' field operations become more productive and efficient,
- value chains become traceable and coordinated down to the smallest detail,
- improve the financial performance of the farm and meet the food needs of a growing population,
- create systems that are highly productive, predictive and adaptive,
- reduce the need for human labour, which is hard to find today anyway for seasonal agricultural activities.

## REFERENCES

- AGRI Committee research (2019). Impacts of the digital economy on the food chain and the CAP. European Parliament.
- Bartzanas, T., Katsolas, N., Kittas, C., Tzounis, A. (2017). Internet of Things in agriculture, recent advances and future challenges, *Biosystems Engineering* 164, 31-48.
- Biel, A., De Clercq, M., Vats, A. (2018). Agriculture 4.0: The future of farming technology, World Government Summit, 1-30
- Bill, R., Nash, E., Grendorfer, G. (2012). GIS in Agriculture u: Handbook Geographic Information (ur. Danko, D., M., Kresse, W.), Springer, Berlin, 795-817.
- Dittmer, P., Veigt, M., Scholz-Reiter, B., Heidmann, N., Paul, S. (2012). The Intelligent Container as a Part of the Internet of Things. In: IEEE International Conference on Cyber Technology in Automation, Control, and Intelligent Systems. Bangkok: IEEE.
- Dlačić, J., Jovanović, M., Okanović, M., 2018: Digitalization and society's sustainable development – Measures and implications, *Zbornik radova Ekonomskog fakulteta Rijeka*, 36 (2), 905 – 928.
- Guangyu, C., Minbo, L, Zhu, Z. (2013). Information Service System of Agriculture IoT, *Automatika: časopis za automatiku, mjerenje, elektromiku, računarstvo i komunikacije* 54 (4), 415 – 426.
- Husnjak, M., Sito, S., Plietić, S., Mudrinić, E. (2021). Suvremene tehnologije kao rješenje za nedostatak radne snage u poljoprivredi- SUTRA, *Studija o mogućnostima zamjene ljudske radne snage automatiziranim i robotiziranim strojevima inovativnim tehnološkim rješenjima u poljoprivredi*. Gospodarski list.
- Jurišić, M., Barač, Ž., Šumanovac, L., Zimmer, D. (2015). Tehnički i tehnološki aspekti pri zaštiti bilja u sustavu precizne poljoprivrede, *Poljoprivreda* 21 (1), 75 – 81.
- Lamešić, D., Deže, J., Kralik, I., Kristić, J. (2019). Blockchain tehnologija u poljoprivredi, *Agroeconomica Croatica* 9 (1), 153 – 160.
- Navadkar, H., V., Nighot, A., Wantmure, R. (2018). Overview of Blockchain Technology in Government/Public Sectors, *International Research Journal of Engineering and Technology*, 5 (6), 2287 – 2292.
- Plietić, S., Galić, A., Dobričević, N., Voća, S. i Šic Žlabur, J. (2017). Noviteti u transportu mesa i mesnih prerađevina. *Krmiva*, 59 (1), 39-45.

Yahya, N. (2018). Agricultural 4.0: Its implementation Toward Future Sustainability u: Green Urea For Future Sustainability, Springer, Singapur, 125-145.



## PERFORMANCE EVALUATION OF PHOTOVOLTAIC SYSTEM IN CONDITIONS OF INDEPENDENT FARM

Dumitru TUCU, Gabriel MALAIMARE, Vasile LEȘ, Nicolae LONTIS\*

\*E-mail of corresponding author: nicolae.lontis@upt.ro

*Mechanical Machines and Transportation, Politehnica University Timisoara,  
No.1, Mihai Viteazu Av., RO-300011 Timisoara, Romania*

### ABSTRACT

*The paper analyses the performance of existing photovoltaic system, placed in an agricultural micro-farm, having the objective to power integral with electricity. The main objective was to analyse the efficiency of real-time solar radiation conversion, in different weather conditions. The experiment based on an existing photovoltaic (PV) system (6 kW, 16 panels, on/off grid function) and a Pessl Instruments Meteo station iMetos 3.3, both placed in the same area, a micro-farm situated in Parta, Timis County, Romania. For three periods of same number of days, between May 16-30th, June 1st-15th, and September 1st-15th, firstly was compared the values of solar radiation measured by pyranometer and captured power by system, on m<sup>2</sup>, as daily average of efficiency.*

*The variation of efficiency as function of solar radiation for the system analysed, corresponding to all three periods, was detailed analysed in special conditions: for rainy days, for hot days, and for different hour of the day. The results obtained from this investigation demonstrated that the efficiency of photovoltaic system varied on each period (15 days) between 13,46% to 16,00%, and average of power system was 32,1% (efficiency use of the installed power system). The influences of other factors on efficiency was less than 2%, so the most important factors for decisions concerning the use of photovoltaic systems in future projects for energetic independent micro-farm must be the construction and performance of panels, in conditions of correct installation and maintenance and reliability of the system. Such PV power systems can be used as power source for all activities and values (different power), integrated with other elements of independent farm concept.*

**Keywords:** *small scale, independent power facilities, efficiency, solar radiation absorption, regression, exponential model, three periods*

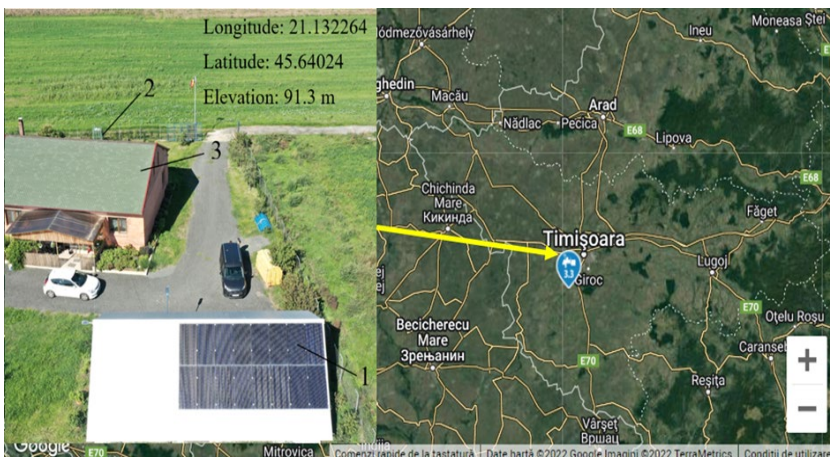
## INTRODUCTION

Because is gaining popularity, the use of small scale independent photovoltaic (PV) power facilities in small independent farms must have essential characteristics, and reduce the greenhouse effect and climate change significantly. Also, the small scale system is suitable for general farmers to implement at low cost. One important objective for farmer by using this system, could be to produce vegetables and electricity at the same time in a farmland (Ge et al., 2015). The extending of the use of photovoltaic (PV) systems is obviously in the projects of independent farms. One of the important problem is such systems are frequently exposed to partial or complete shading phenomena (disposure between buildings, weather, etc.), and could has a profound impact on the performance of power generation (Abdulmawjood et al., 2022). The operational performance of PV in conditions of partial shading shows multiple maximum power point peaks (Yi et al., 2014; Buragohain et al., 2015; Singh, 2013; Bhattacharjee et al., 2018). Optimization of such systems has challenging to permanently identify the maximum power point by using different models: array reconfiguration to reduce partial shading loses (Yadav and Mukherjee, 2021; El-Dein, 2013), functional analysis (Babanatis Merce, 2018), the use of bypass diode application on photovoltaic modules (Vieira et al., 2020), etc. For the future is important to introduce automation of activities, alternative fuels (example by-products biomass pyrolysis (Filipovici et al., 2017)), and solar road integration on farm power flow (Wei et al., 2022).

Focusing on the performance of an existing photovoltaic system, placed in an agricultural micro-farm, this paper has the main objective to evaluate the behaviour of the power generating system to power integral (and possible extending) with electricity the farm activities.

## METHODS

The photovoltaic (PV) system involved in experiment was situated in a micro-farm positioned in locality Parța, Timiș County (figure 1), where, 1- Stall, 2 – Meteo station, 3 - Administration.



**Figure 1** Position of experiment farm (Picture from drone, map from Google)

The technical characteristics of equipment are:

PV panel, MWG-370 Mono (black), monocrystalline structure, 370 W, 38.43 V, 9.628 A, IP 65, dimensions 1956 x 992 x 40 mm $\cdot 10^{-3}$ ;

Inverter Fronius Symo 7.0 – 3 – M, 2 MPP trackers, 16 A, 150 - 1000 V DC input voltage range, 595 V Nominal input voltage, 14 kW peak maximum PV generator power, 7000 W maximum output power, 97,6 % European efficiency;

In the same position was situated a Pessl Instruments Meteo station iMETOS 3.3, global radiation sensor LI-200S.

For three periods (I-16-30<sup>th</sup>, May 2022; II- 1-15<sup>th</sup>, June 2022; III- 1-15<sup>th</sup>, September 2022) were monitored the power of solar radiation by the meteo station pyranometer and the electric power generated by the system using Solarweb application. The measurement had a 10 minutes frequency.

For analysing the measured values two variable were used: total efficiency of PV conversion by power system, TEF and efficiency of using power systems' capacity, SEF, calculated by formulas:

$$\text{TEF} = \frac{100 \cdot E_e}{SR}, [\%] \text{ and} \quad (1)$$

$$\text{SEF} = \frac{100 \cdot E_e}{Et}, [\%], \text{ where:} \quad (2)$$

SR – total measured power of solar radiation for equivalent surface of the PV power system, [Wh $\cdot 10^3$ ]

E<sub>e</sub> – total power generated by system, [Wh $\cdot 10^3$ ]

E<sub>t</sub> – installed power of the system, = 5,92 [Wh $\cdot 10^3$ ]

Afterwards the values were summarized on hour and on day. Using Microsoft Excel and STATEGRAPHICS Centurion XVI the statistical analyse was made for relevance of relationship between SR and SEF, respectively TEF. The relevance was verified using Fisher test, and one-way ANOVA for possible relations between previous variables. Conclusions and results of present study were prepared to be recommended for design and practical optimization of the PV power systems in agricultural farms.

## RESULTS AND DISCUSSION

Tables 1, 2 and 3 present the daily values of measured and calculated variables previous mentioned, respectively I, II and III period.

For the period I, the statistical analysis shows the equation of the fitted model as an exponential model to describe the relationship between SEF and SR:

$$(I)\text{SEF} = \exp(1.96663 + 0.00685808 \cdot \text{SR}) \quad (3)$$

The R-Squared value indicates that the model explains 94.0367% of the variability in SEF after transforming to a reciprocal scale to linearize the model. The correlation coefficient (value 0.969725), indicating a relatively strong relationship between the variables. The P-value is less than 0.05, so there is an indication of possible serial correlation at the 95.0% confidence level.

**Table 1** Daily values of measured and calculated variable for period I

No.	Date	SR, [Wh·10 <sup>3</sup> ]	Ee, [Wh·10 <sup>3</sup> ]	SEF, [%]	TEF, [%]
1	16.05.2022	218.34	31.23	34.748	14.19
2	17.05.2022	173.55	25.09	27.454	14.24
3	18.05.2022	272.81	39,50	43.936	14.49
4	19.05.2022	273.13	37.73	41.995	13.84
5	20.05.2022	266.43	37.42	41.628	14.06
6	21.05.2022	224.31	30.98	34.474	13.83
7	22.05.2022	263.86	37.05	41.231	14.06
8	23.05.2022	250.57	34.58	38.736	13.91
9	24.05.2022	194.75	27.24	30.313	14.01
10	25.05.2022	245.79	34.32	38.384	14.06
11	26.05.2022	222.91	31.16	34.683	14.00
12	27.05.2022	266.07	36.13	40.247	13.61
13	28.05.2022	39.01	6.26	6.973	16.09
14	29.05.2022	98.77	14.12	15.722	14.33
15	30.05.2022	153.18	21.42	23.840	14.01

**Table 2** Daily values of measured and calculated variable for period II

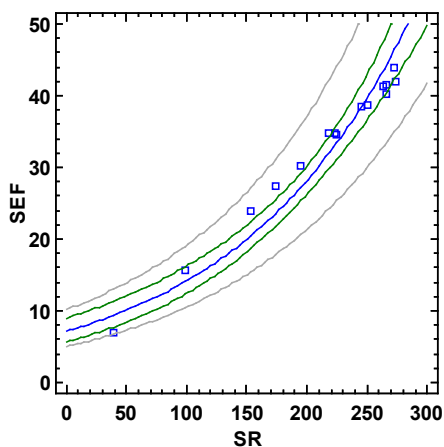
No.	Date	SR, [Wh·10 <sup>3</sup> ]	Ee, [Wh·10 <sup>3</sup> ]	SEF, [%]	TEF, [%]
1	01.06.2022	262.95	35.64	13.57	39.66
2	02.06.2022	225.94	30.68	13.60	34.15
3	03.06.2022	250.51	32.77	13.10	36.47
4	04.06.2022	224.05	31.15	13.93	34.67
5	05.06.2022	251.13	33.06	13.18	36.79
6	06.06.2022	271.02	35.73	13.20	39.74
7	07.06.2022	268.21	35.61	13.30	39.63
8	08.06.2022	264.26	35.86	13.59	39.90
9	09.06.2022	212.35	28.77	13.63	32.15
10	10.06.2022	255.84	34.73	13.57	38.59
11	11.06.2022	237.43	31.03	13.17	34.74
12	12.06.2022	285.94	36.15	12.68	40.30
13	13.06.2022	215.36	35.21	16.29	38.99
14	14.06.2022	277.57	34.64	12.49	38.52
15	15.06.2022	289.99	36.38	12.56	40.47



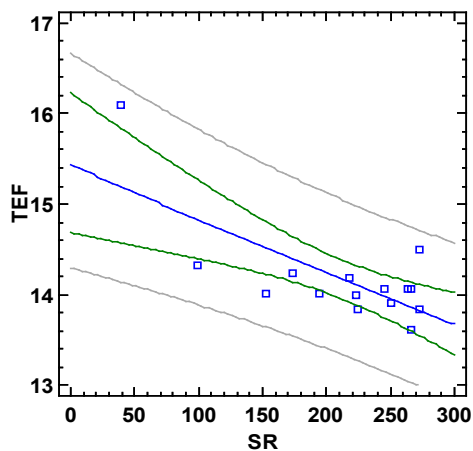
**Table 3** Daily values of measured and calculated variable for period III

No	Day	SR, [Wh·10 <sup>3</sup> ]	Ee, [Wh·10 <sup>3</sup> ]	SEF, [%]	TEF, [%]
1	01.09.2022	80.38	11.86	13.20	14.78
2	02.09.2022	23.79	3.76	4.19	15.86
3	03.09.2022	79.31	10.83	12.05	13.67
4	04.09.2022	190.80	31.68	35.25	16.63
5	05.09.2022	197.30	33.10	36.85	16.81
6	06.09.2022	198.27	33.37	37.13	16.85
7	07.09.2022	193.90	33.99	37.90	17.59
8	08.09.2022	183.39	32.52	36.18	17.76
9	09.09.2022	94.43	14.10	15.71	14.98
10	10.09.2022	121.23	19.08	21.26	15.78
11	11.09.2022	159.07	25.77	28.66	16.21
12	12.09.2022	183.92	23.15	25.76	12.61
13	13.09.2022	175.64	30.30	33.75	17.29
14	14.09.2022	162.14	29.85	33.32	18.50
15	15.09.2022	87.31	12.79	14.23	14.66

The plot of fitted model with 95 % prediction limits can be seen in figure 2.



**Figure 2** STATEGRAPHICS plot of the fitted model, relation  $SEF=f(SR)$ , period I



**Figure 3** STATEGRAPHICS plot of the fitted model, relation  $TEF=f(SR)$ , period I

In the same period, the statistical analysis shows the appropriate equation of the fitted model as an exponential model for the relationship between TEF and SR (the plot of fitted model can be seen in figure 3):

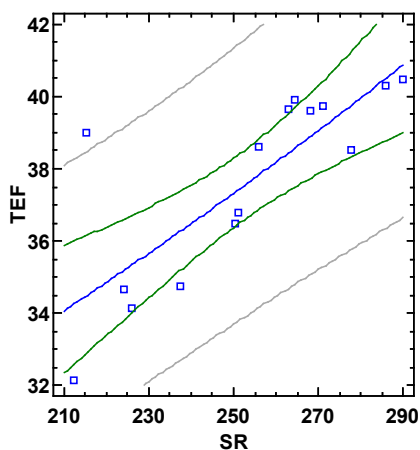
$$(I)TEF = \exp(2.73658 - 0.000404501*SR) \tag{4}$$

This time the R-Squared value indicates that the model explains 53.4145% of the variability in TEF. The correlation coefficient (value 0.730852), indicated a relatively weak relationship between the variables. The P-value is greater than 0.05, there is no indication of serial autocorrelation in the residuals at the 95.0% confidence level.

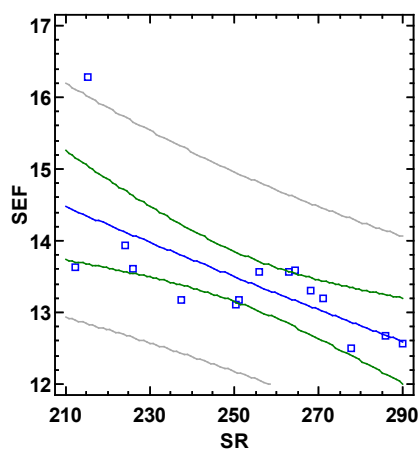
Similarly in the period II, from statistical analysis results the next equation for the fitted model as an exponential model to describe the relationship between SEF and SR:

$$(II)SEF = \exp(3.03777 - 0.00174073*SR) \tag{5}$$

The R-Squared statistic indicates that the model as fitted explains 48.906% of the variability in SEF after transforming to a reciprocal scale to linearize the model and the correlation coefficient equals 0.699328, indicating a moderately strong relationship between the variables. The P-value is greater than 0.05, results no indication of serial autocorrelation in the residuals at the 95.0% confidence level.



**Figure 4** STATEGRAPHICS plot of the fitted model, relation SEF=f(SR), period II



**Figure 5** STATEGRAPHICS plot of the fitted model, relation TEF=f(SR), period II

Regarding relationship between TEF and SR in the same period, the statistical analysis shows the appropriate equation of the fitted model as an exponential model for the relationship between TEF and SR:

$$(II)TEF = \exp(3.04823 + 0.00228509*SR) \tag{6}$$

In this situation the R-Squared value indicates that the model explains 62.4947% of the variability in TEF. The correlation coefficient (value 0.790536), indicated a moderately strong relationship between the variables. The P-value is greater than 0.05, there is no indication of serial autocorrelation in the residuals at the 95.0% confidence level.

The plot of fitted models corresponding to period II are presented in figure 4, respectively 5.

For the period III, the statistical analysis shows the equation of the fitted model as an exponential model to describe the relationship between SEF and SR:

$$(III)SEF = \exp(1.59072 + 0.0106737*SR) \tag{7}$$

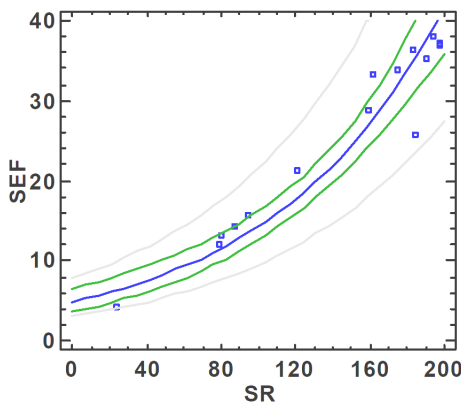
The R-Squared value indicates that the model explains 91.3082% of the variability in SEF after transforming to a reciprocal scale to linearize the model. The correlation coefficient (value 0.955553), indicating a relatively strong relationship between the variables. The P-value is less than 0.05, so there is an indication of possible serial correlation at the 95.0% confidence level.

In the same period, the statistical analysis shows the appropriate equation of the fitted model as an exponential model for the relationship between TEF and SR:

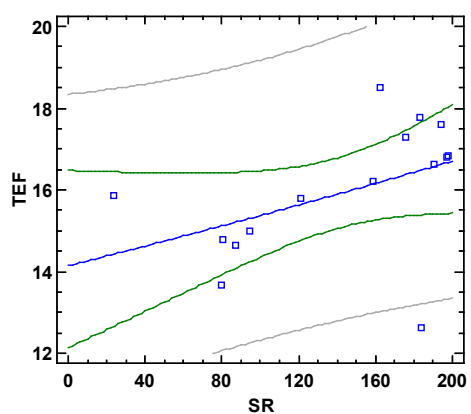
$$(III)TEF = \exp(2.6495 + 0.000830761*SR) \tag{8}$$

This time the R-Squared value indicates that the model explains 19.7942% of the variability in TEF. The correlation coefficient (value 0.444906), indicated a relatively weak relationship between the variables. The P-value is greater than 0.05, there is no indication of serial autocorrelation in the residuals at the 95.0% confidence level.

The plot of fitted model for relations  $SEF=f(SR)$  and  $TEF=f(SR)$  are presented in figure 6, respectively 7.

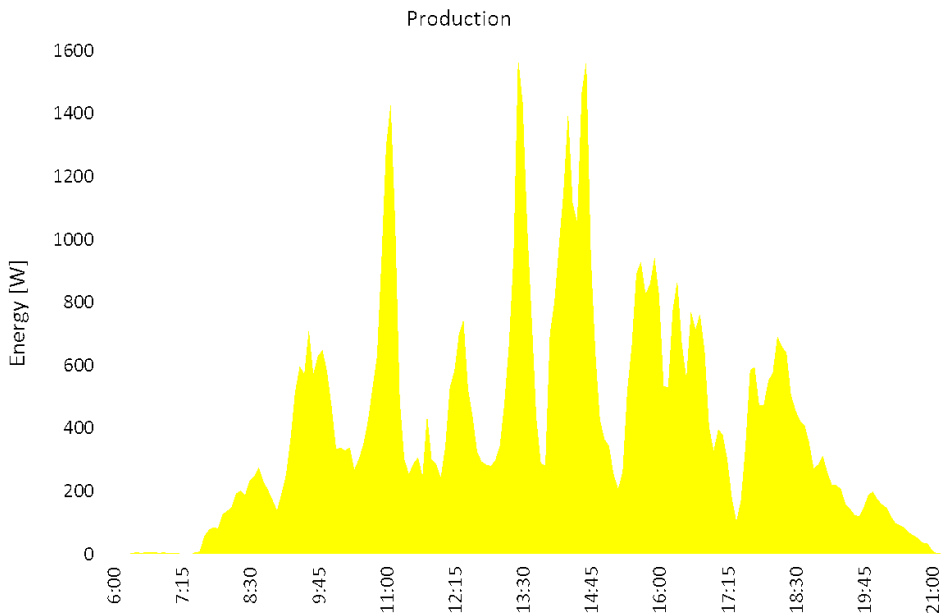


**Figure 4** STATEGRAPHICS plot of the fitted model, relation  $SEF=f(SR)$ , period III



**Figure 5** STATEGRAPHICS plot of the fitted model, relation  $TEF=f(SR)$ , period III

The results after statistical analysis demonstrated the mismatching loss of power system performances under different shading conditions. The dependencies between solar radiation (SR) and total (TEF) or specific efficiency of the system (SEF) indicated different levels of possible serial correlation at the 95.0% confidence level (from strong to weak correlations). After verification of recorded information regarding weather, the fluctuations (strong rainy days to hot days), could be explanations for each period. For example, figure 8 presents the hourly variation of total power generated by system in May 28<sup>th</sup>, 2022, corresponding to a strong weather variable day.



**Figure 8** Hourly variation of total power generated by system in May 28th, 2022

## CONCLUSIONS

This paper presents the global impact of different weather conditions on the PV power generator performances in a specific configuration used in small independent farm. The results showed multiple local peaks and a global peak on the output PV power generator performances. The obtained results also demonstrate the difficulty to find a global prediction model for estimate and simulate the future performances of such systems. Furthermore, the value of the global performances depends on the employed array configuration, the shading layout and the shading intensity. Therefore, more comparative investigations are required to better understand the effectiveness of optimum reconfiguring PV modules.

## REFERENCES

- Abdulmawjood, K., Alsadi, S., Refaat, S.S., Morsi, W.G. (2022). Characteristic Study of Solar Photovoltaic Array under Different Partial Shading Conditions. In: *IEEE Access*, Vol.10, 6856-6866
- Bhattacharjee, S., Bhattacharjee, S., Mazumdar, A., Changmai, P., Chowdhury, M.K. (2018). An approach to enhance the efficiency of the solar PV panel in partial shading condition: A Review. *ADBU J. Elect. Electron. Eng. (AJEEE)*, vol. 2, no. 1, 5-7
- Ge, Z.W., Bian, X.F., Wei, J.D. (2015). Design of Small Scale Independent Photovoltaic Facilities above Farm Land. In: *International Conference on Environmental Protection and Human Health (EPHH)*, Wuhan, PEOPLES R CHINA, 469-472
- Yi, Y., Sheng-lan, J., Hai-qin, G., Juan C. (2014). Simulation study on characteristics of photovoltaic array under partial shading. In *Proc. 33rd Chin. Control Conf.*, Nanjing, China, 6992-6997
- Buragohain, S., Mahapatra, S., Sarmah, N., Kumar S. (2015). Shading and mismatch effect on the performance of PV module," in *Proc. Int. Conf. Adv. Energy Res. (ICAER)*
- Singh, G.K. (2013). Solar power generation by PV (photovoltaic) technology: A review. *Energy*, vol. 53, 1-13
- El-Dein, M., Kazerani, M., Salama, M.M.A. (2013). Optimal photovoltaic array reconfiguration to reduce partial shading losses. *IEEE Trans. Sustain. Energy*, vol. 4, no. 1, 145-153
- Babanatis Merce, R.M., Babanatsas, T., Maris, S., Tucu, D., Ghergan, O.C. (2018). Study of an automatic olives sorting system. In: *Actual Tasks on Agricultural Engineering*, Zagreb, Vol. 46, 485-490
- Filipovici, A., Tucu, D., Bialowiec, A., Bukowski, P., Crisan, G.C., Lica, S., Pulka, J., Dyjakon, A., Debowski, M. (2017). Effect of Temperature and Heating Rate on the Char Yield in Sorghum and Straw Slow Pyrolysis. *Revista de chimie*, Vol. 68, Iss. 3, 576-580
- Yadav, A.S., Mukherjee, V. (2021). Conventional and advanced PV array configurations to extract maximum power under partial shading conditions: A review. *Renew. Energy*, vol. 178, 977-1005
- Vieira, R., de Araújo, F., Dhimish, M., Guerra, M. (2020). A comprehensive review on bypass diode application on photovoltaic modules. *Energies*, vol. 13, no. 10, 2472,
- Wei, Dai., Bochen, S., Tengfei L., HuiHwang G., Jinghua L. (2022). Power flow analysis considering solar road generation. *Energy Reports* 8 (2022), 531–536

---

---



## VALORIFICATION OF THE NETTLE PLANTS FROM SPONTANEOUS FLORA AS NETTLE POWDER – MINERALIZING POTENTIAL IN ANIMAL FEED

Ariana-Bianca VELCIOV<sup>1</sup>, Iasmina Madalina ANGHEL<sup>2</sup>, Maria RADA<sup>3</sup>,  
Vlad MĂRĂZAN<sup>4</sup>, Antoanela COZMA<sup>1\*</sup>

\*E-mail corresponding authors: antoanelacozma@yahoo.com

<sup>1</sup> Food Science Department, Faculty of Food Engineering, University of Life Sciences "King Michael I" Timisoara, Calea Aradului, 300645, Timisoara, Romania

<sup>2</sup> Materials and Manufacturing Engineering Department, Politehnica University of Timișoara, 300222, Timișoara, Romania

<sup>3</sup> University of Medicine and Pharmacy "Victor Babes", 2 Eftimie Murgu Sq., 300041, Timisoara, Romania

<sup>4</sup> Department of Overland Communication Ways, Foundation and Cadastral Survey, Politehnica University of Timișoara, 300006, Timișoara, Romania.

### ABSTRACT

*Nettles (genus Urtica, family Urticaceae) are rich sources of nutrients and biologically active compounds. Special attention must be paid to these valuable plants considering the possibility of their use in both food and fodder formulations. However, the use of nettle plants in animal nutrition is limited as animals reject them due to their characteristic urticating's hairs in leaves and stems, which on contact with the skin or mucosae trigger an erythematous macula, itchiness, and pain. This inconvenience can be solved by drying and grinding the plant to obtain a dehydrated powder that could be easily homogenized with other fodder raw materials, and used for animal feed as combined fodder. In this way, the problem of superior use of natural resources generated by spontaneous flora can be solved. This experiment aims to obtain nettle powder and evaluate the mineral profile in order to use it for the mineral enrichment of animal feed. Three portions of powder from wild nettle leaves (Urtica dioica L.) originating from the spontaneous flora of three plain areas of Timis County (Romania) were prepared. Samples were analyzed from the content of essential mineral elements point of view. The obtained results after mineral concentration of nettle powder determination, prepared under laboratory conditions: 170.8 – 236.4 ppm Na, 25,340 – 29,210 ppm K, 21,150 – 24,89 ppm Ca, 7,810 – 9,020 ppm Mg, 267 – 442 ppm Fe, 38.8 - 67.6 ppm Mn, 19.5 – 31.1 ppm Zn and 8.7 - 16.2 ppm Cu, shows that nettle powder contains increased amounts of macro elements (especially K and Ca but also*

*Mg) and important contents of essential microelements (especially Fe but also and Mn, Zn, Cu). According to these results, it can be stated that the analyzed nettle powder could be used as a mineral supplement in animal feed.*

**Keywords:** *Nettle, nettle leaves powder, macro and microelements, animal feed.*

## INTRODUCTION

Animal feed is an essential link in the food chain that directly influences both animal health and welfare and food safety. A healthy and rich food should contain proteins, carbohydrates, fats, minerals, vitamins and water.

The notion of "feed" or "feed products" is defined in Article 3(4) of Regulation (EC) no. 178/2002 as "any substance or product, including additives, whether processed, partially processed or unprocessed, intended for use as oral animal feed". From a nutritional point of view, animal feed must contain sufficient amounts of constituents to give it nutritional value (amino acids, fatty acids, carbohydrates, minerals and vitamins, etc.). If the animal breeders feed the animals using fodder with low nutritional value (poor in proteins, carbohydrates, minerals, vitamins, etc.), it is necessary to supplement them with nutrients or additives necessary for the basic diet. Feed additive is an ingredient or combination of ingredients added to the basic diet to meet specific needs or to increase performance. Mineral additives are also included in the category of additives used in animal feed. Mineral elements, in the form of macro and micro elements (Ca, P, Mg, Na, K, etc., respectively Cu, Zn, Mn, Fe, Co, I, Se, etc.) play an important role in the animal body, they are essential for the growth, development, reproduction and animals health. The optimal mineral intake is influenced by their involvement in ensuring the structural, catalytic, physiological and regulatory functions in the animal body (Table 1) (Chandra et al., 2015; Thakur and Mahesh, 2015).

As can be seen from Table 1, mineral elements have important roles in maintaining the homeostasis of the animal body, they stimulate the appetite, implicitly contributing to the growth and development of animals, support fertility and the immune system, increasing the quantity and quality of animal foods etc. (Chandra et al, 2015). Therefore, healthy and performing animals must be provided with a mineral requirement corresponding to their needs. If the fodder used as feed does not fully provide these mineral elements, the animal breeder should supplement the livestock feed with concentrated mixtures of mineral salts or herbs containing increased amounts of calcium, potassium, sodium, magnesium, selenium, iron, manganese, cobalt, etc. (Pandey et al., 2019).

Additives from herbs are used as natural additives containing a number of phytochemicals such as alkaloids, saponins, tannins, glycosides, essential oils, phytoestrogens, glucosinolates, etc. (Singhal and Thakur, 2005). They are used in animal diets to improve intake, performance, health and reduce methane emissions. (Jain et al., 2013). One of these plants that belongs to the Urticaceae family is Stinging nettle (*Urtica dioica* L.), which is widely cultivated in the world and is noted as a plant with medicinal properties. Numerous species of nettles can be used to improve animal health because they contain more than 50 different chemical compounds, especially their active and effective antioxidant compounds (Pant and Sundriyal, 2016).



**Table 1** The role of some essential minerals in animal body

<b>Element</b>	<b>Functions</b>
Calcium	Bone and teeth formation, blood clotting, muscle contraction, 0.12% in milk and 0.23% in colostrum.
Magnesium	Enzyme activator, found in skeletal tissue and bone, important for muscle relaxation, cofactor in second messenger systems in cell communication
Sodium	Acid-base balance, muscle contraction, nerve transmission.
Potassium	Maintenance of electrolyte balance, enzyme activator, muscle and nerve function.
Iron	Part of hemoglobin and many enzymes.
Copper	Needed for the synthesis of hemoglobin, part of many enzymes.
Cobalt	Part of vitamin B12, needed for growth of rumen microbes.
Manganese	Growth, bone formation, enzyme activator.
Zinc	Enzyme activator, influences immune response.
Selenium	Component of glutathione peroxidase, cellular antioxidant functions with vitamin E.

The Stinging nettle (*Urtica dioica* L.), belonging to the Urticaceae family is a perennial plant native to temperate and tropical Asia, Europe, North America and North Africa that commonly grows in wastelands, gardens, farmers' field (as a weed), as a hedge live in terraced fields (Pant, 2019). Stinging nettle is a perennial edible whose leaves are a relatively good source of caloric energy, protein, fiber, and an array of health-promoting bioactive compounds which include vitamins A, C, and K, fatty acids ( $\alpha$ -linoleic and linoleic acid), minerals (Fe, Mn, K, and Ca) and nine carotenoids (lutein and lutein isomers,  $\beta$ -carotene, and  $\beta$ -carotene isomers (Bauman and Perez, 2018). Nettle leaves are rich in proteins, fats, carbohydrates, vitamins, minerals and trace elements (Said et al., 2015; Pant, 2019; Rafajlovska et al. 2013). Dried nettle contains 30% protein with a much better amino acid profile than other leafy plants. The fact that nettle is a food with high nutritional and functional values was also supported by Devkota et al., 2013. Nettle is a good source of essential amino acids and polyunsaturated fatty acids (Upton, 2013).

Nettle powder contains relatively high amounts of bioactive compounds and crude protein, fiber, ash (30.54, 10.16 and 15.24%, respectively (Eldamaty, 2018). According Maaroufi et al. (2016) and Mzid et al. (2017), nettle powder also contains relatively high amounts of bioactive compounds as tannin, total phenolic and total dietary fractions. Some researchers have reported that its leaves exhibit excellent antioxidant and antimicrobial properties. In addition, nettle leaves contain several minerals such as: Ca, Fe, Mg, Co, Mn, P, K, and K (Said et al., 2015; Abdul-Majeed et al., 2021; Rafajlovska et al., 2013; Pant, 2019).

The presence of valuable biologically important compounds such as proteins, vitamins, phenolic components, macro and microelements, tannins, flavonoids, sterols, fatty acids, carotenoids and chlorophylls (Bhusal et al., 2022; Devkota et al., 2022), contributes to the

utilization of stinging nettle in different ways, in several fields such as agriculture, cosmetics, textiles, medicine and food (Adhikari et al., 2016; Bourgeois et al. 2016).

According Arros et al., 2020, due to its proximate and mineral composition ( $96 \pm 1.2$  % dry matter,  $24 \pm 2.8$  % crude protein,  $8.4 \pm 2.2$ % crude fiber,  $2.9 \pm 0.9$ % ether extract,  $29.1 \pm 2.0$ % ash,  $31.6 \pm 2.1$ % nitrogen-free extract,  $1.65 \pm 0.37$ % Ca,  $0.44 \pm 0.05$ % Mg,  $0.51 \pm 0.02$ % P,  $9.9 \pm 0.2$  mg/100g Cu,  $1.8 \pm 0.5$  mg/100g Fe,  $20.1 \pm 1.2$  mg/100g Zn, fatty acids and aminoacids) nettle powder might become an interesting ingredient for animal diets formulation (Arros et al., 2020).

However, the use of nettle plants in animal nutrition is limited as animals reject them due to their characteristic urticating hairs in leaves and stems, which on contact with the skin or mucosae trigger an erythematous macula, itchiness, and pain. Because trichomes are sensitive to heat (Arros et al. 2020.) this inconvenience can be solved by drying and grinding the plant to obtain a dehydrated powder that could be easily homogenized in animal feed.

The consulted literature presents numerous aspects regarding the benefits of using nettle (boiled or as powder) in the feed of poultry, cattle, pigs, rabbits (Milosevic et al. (2021); Al-Salihi et al. (2018); Bhusal et al. 2022; Abdul-Majeed., 2021; Moula et al., 2019; Khanal, et al., 2017; Otwinowska-Mindur et al., 2021). In vitro studies indicate that stinging nettle has the potential to be used in order to promote rumen health by stabilizing rumen pH in animals consuming high levels of readily fermentable carbohydrates. Stinging nettles have also been used to treat some animal diseases: (genital and skin diseases, gastrointestinal disorders, hematuria, rheumatism, infertility, bone fractures, wounds and sprains, breastfeeding, abdominal pain and other internal injuries, etc. (Humphries and Reynolds, 2014; Disler et al., 2014).

The benefits of using stinging nettle in animal feeds are due to the quantity and quality of the nutritional and biologically active components included in the composition of this plant. The nutritional and therapeutic quality of stinging nettle is also determined by the amount of essential mineral elements contained in this plant, among which are Zn ( $15.2$  mg  $\text{kg}^{-1}$ ), Fe ( $14.686$  mg  $\text{kg}^{-1}$ ) and Cu ( $0.6414$  mg  $\text{kg}^{-1}$ ) (Biadg Fetene, 2022); K ( $2.59$ - $3.41$ %), Ca ( $2.21$ - $3.97$ %), Mg( $0.42$ - $0.81$ %), Fe ( $112.60$ - $526.20$  mg  $\text{kg}^{-1}$ ), Cu ( $10.23$  -  $18.42$  mg  $\text{kg}^{-1}$ ), Mn ( $30.50$  -  $57.40$  mg  $\text{kg}^{-1}$ ), Zn ( $12.70$ - $34.30$  mg  $\text{kg}^{-1}$ ) (Paulauskiene et al., 2021); Na ( $3.3$ - $3.4$  mg  $100$  g $^{-1}$ ), K ( $1279$ -  $1354$  mg  $100$  g $^{-1}$ ), Ca ( $2065$ - $2283$  mg  $100$  g $^{-1}$ ), Mg ( $726$ - $740$  mg  $100$  g $^{-1}$ ), Fe ( $17.6$  - $17.9$  mg  $100$  g $^{-1}$ ), MN ( $.6$ - $2.7$  mg  $100$  g $^{-1}$ ), Zn ( $3.8$  mg  $100$  g $^{-1}$ ) (Shonte et al., 2020).

The purpose of this experiment is to obtain nettle powder from wild nettle leaves (*Urtica dioica*) originating from the spontaneous flora and to evaluate the mineral profile in order to use it to increase the mineral concentration of animal feed.

Achieving this objective could contribute to the efficiency of the use of plant resources from the spontaneous flora to supplement the mineral diet of the animals.

## MATERIALS AND METHODS

### *Plant material*

For the preparation of nettle powder, wild nettle leaves (*Urtica dioica*) were collected from three plain areas of Timis county (Romania). They were cleaned and washed under running

tap water to remove mechanical impurities, after which they were left to dry at room temperature, until the crispy texture was observed. The dried leaves were ground using a coffee grinder, when a fine dark brown powder was obtained. Until the analysis, the powder samples were placed in brown glass vials and kept cold.

#### ***Determination of mineral elements***

The essential mineral element in nettle powder were carried out according to the method recommended and used by Velciov et al. (2015) when a similar product was analyzing. The determination consists in the calcination of the nettle sample at 550°C, followed by the solubilization of the ash in HNO<sub>3</sub> 0.5 N and the measurement of mineral element concentrations using the FS Varian 280 Spectrometer.

## **RESULTS AND DISCUSSION**

The results obtained after determining the concentration of essential mineral elements (Na, K, Ca, Mg, Fe, Mn, Zn and Cu) determined in nettle powders from the spontaneous flora of the plain area of Timis county are presented in Table 2.

**Table 2** The distribution of some mineral elements in nettle powder

<b>Specification</b>	<b>Mineral element (ppm)</b>	
	<b>Limits</b>	<b>Mean value</b>
<b>Na</b>	170.8 - 236.4	206.5 ± 27.09
<b>K</b>	25,340 - 29,210	27,290 ± 1,580
<b>Ca</b>	21,150 - 24,890	23,132 ± 1,535
<b>Mg</b>	7,810 - 9,020	8,401 ± 494
<b>Fe</b>	267 - 442	360 ± 71.86
<b>Mn</b>	38.8 - 67.6	52.97 ± 11.76
<b>Zn</b>	19.5 - 31.1	26.4 ± 4.98
<b>Cu</b>	8.7 - 16.2	13.03 ± 3.17

As can be seen from table 2, the concentration of the analyzed mineral elements shows obvious non-uniformity, depending on the type of element and the nature of the sample, an aspect also recorded by Opačić N. et al. (2022). Among the analyzed mineral elements, the best represented are potassium, calcium and magnesium, determined in the following concentration limits: 25,340 – 29,210 ppm K; 21.150-24.89 ppm Ca; 7,810–9,020 ppm Mg. Sodium, although it has an macroelement status, was identified in much lower concentrations compared to K, Ca and Mg (170.8–236.4 ppm Na). Mineral microelements were determined in much lower concentrations than macroelements (except Na), their concentration limits showing the following values: 267 - 442 ppm Fe, 38.8 - 67.6 ppm Mn, 19.5 - 31.1 ppm Zn and 8.7 - 16.2 ppm Cu.

Comparing the values obtained after determining the concentrations of mineral elements with the values reported by other authors when analyzing similar products (Arros et al. 2020; Shonte et al., 2020; Jan et al. 2017; Rafajlovska et al., 2013; Paulauskienė et al., 2021; Kumar et al., 2021; Biadg Fetene et al. 2022; Mihaljev et al, 2014) it can be stated that in general the values are relatively close. The differences are justified by the fact that the mineral profile of nettle powder is determined by a number of factors: the species of the plant, the soil conditions, the climate and other factors of an anthropical or geogenic nature, the period of harvesting the leaves, and last but not least, the method of preparation and sample analysis (Paulauskienė et al., 2021; Shonte et al., 2020).

The average concentration values for the essential elements determined in nettle powder, show that this product obtained under the conditions of the present experiment, contains increased amounts of K ( $27,290 \pm 1,580$  ppm), Ca ( $23,132 \pm 1,535$  ppm) and Mg ( $8,401 \pm 494$  ppm) and important Fe ( $360 \pm 71.86$  ppm) and Na amounts ( $206.5 \pm 27.09$  ppm) and appreciable Mn ( $52.97 \pm 11.76$  ppm), Zn ( $26.4 \pm 4.98$  ppm) and Cu ( $13.03 \pm 3.17$  ppm) amounts. Considering the concentrations of these essential minerals, as well as their importance in the proper functioning of the animal body (table 1.), as well as the opinions of some researchers in the field (Arros et al., 2020; Bhusal et al., 2022), it can be stated that the analyzed nettle powder could be used as a mineral supplement in animal feed. In addition, nettle powder also contains important amounts of biologically active substances that positively influence the animal's health and breeding, thus increasing the production of animal foods.

## CONCLUSIONS

Nettle powder obtained by drying and grinding nettle leaves grown spontaneously in pollution-free areas, contains important amounts of mineral elements with structural, catalytic, physiological and regulatory functions in the animal body. The distribution of these mineral elements, essential for the growth and development of animals, as well as for increasing the production of animal foods, determined in leave nettle powder analyzed is uneven:  $206.5 \pm 27.09$  ppm Na;  $27,290 \pm 1,580$  ppm K;  $23,132 \pm 1,535$  ppm Ca;  $8,401 \pm 494$  ppm Mg,  $360 \pm 71.86$  ppm Fe;  $52.97 \pm 11.76$  ppm Mn;  $26.4 \pm 4.98$  ppm Zn;  $13.03 \pm 3.17$  ppm Cu. These values show that nettle powder contains increased amounts of macro elements (especially K and Ca but also Mg) and important contents of Na, and essential microelements (especially Fe but also and Mn, Zn, Cu). The average concentrations of the essential elements analyzed in leave nettle powders show the following decreasing trend:  $K > Ca > Mg >> Fe > Na > Mn > Zn > Cu$ . According to these results, it can be stated that the analyzed nettle powder could be used as a mineral supplement in animal feed. Moreover, the increased content in nutritional facts and phytochemicals from leave nettle powder favors its use in animal feed. In addition, the introduction of nettle powder can contribute to the efficient utilization of the natural resources of nettle plants grown in the spontaneous flora.

## ACKNOWLEDGEMENTS

The present paper was funded by the Research Project "Research on the use of biologically active substances in order to obtain high-nutrition foods", No 1545/28.02.2019.

## REFERENCES

- Abdul-Majeed, A.F., Rahawi, Gh.A., Al-Chalabi, A.M. (2021). Effect of adding nettle plant on some physiological and biochemical parameters of broiler chickens, *Iraqi Journal of Veterinary Sciences*, 35, Supplement III: 115-119. doi [10.33899/ijvs.2021.131844.2010](https://doi.org/10.33899/ijvs.2021.131844.2010).
- Adhikari, B.M., Bajracharya, A., Shrestha, A.K. (2016). Comparison of nutritional properties of stinging nettle (*Urtica dioica*) flour with wheat and barley flours, *Food Sci Nutr* 4:119e24.
- Al-Salihi, A.A., Hassan, M.A., Al-Gharawi, J.K. (2018). Effect of using water extract of nettle leaves (*Urtica dioica*) on some immunological and blood traits of broiler, *J Res Ecol*. 6(2):1794-1799.
- Arros, F., Garrido, C., & Valenzuela, C. (2020). Development and characterization of nettle-leaves powder (*Urtica urens*) as a potential supplement for animal feed. *Revista de la Facultad de Ciencias Agrarias UNCuyo*, 52(1): 353-359.
- Bauman, H, Perez, J. (2018). Food as medicine: Stinging nettle (*Urtica dioica*, *Urticaceae*), *Herbal EGram*. 15(7).
- Bhusal, K.K., Magar, S.K., Thapa, R., Lamsal, A., Bhandari, S., Maharjan, R., Shrestha, S., Shrestha, J. (2022). Nutritional and pharmacological importance of stinging nettle (*Urtica dioica* L.): A review, *Heliyon* 8. e09717. <https://doi.org/10.1016/j.heliyon.2022.e09717>
- Biadg Fetene (2022). Determination of the Level of Traces Essential Metals (Cu, Fe & Zn) and Toxic Metals (Pb & Cd) from Nettle Leaves (*Urtica dioica* L.) Grown from Gozamin Woreda, *Modern Chemistry*, 10(1):12-22, doi: 10.11648/j.mc.20221001.13.
- Bourgeois, C., Leclerc, E.A., Corbin, C., Doussot, J., Serrano, V., Vanier, J., Seigneuret, J., Auguin, D., Pichon, C., Laine, E., Hano, C. (2016). Nettle (*Urtica dioica* L.) as a source of antioxidant and anti-aging phytochemicals for cosmetic applications, *Comput. Rendus Chim*. 19:1090e100.
- Chandra, S., Kumar, N., Bhakat, M., Kumar, A., Barjibhe, S, Kumar, N., Devi, I., Kumar, A., Yadav, A.K. (2015). Role of Minerals, Vitamins and Feed Additives in Reproductive Performance of Dairy Animals, *Indian farmer*, 2(12):938-942.
- Devkota H.P., Paudel, K.R., Khanal, S., Baral, A., Panth, N., Adhikari-Devkota, A., Jha, N.K., Das, N., Singh, S.K., Chellappan, D.K., Dua K., Hansbro, P.M. (2022), Stinging Nettle (*Urtica dioica* L.): Nutritional Composition, Bioactive Compounds, and Food Functional Properties, *Molecules*, 27, 5219. <https://doi.org/10.3390/molecules27165219>
- Disler, M., Ivemeyer, S., Hamburger, M., Vogl, C.R., Tesic, A., Klarer, F., Meier, B., Walkenhorst, M. (2014). Ethnoveterinary herbal remedies used by farmers in four north-eastern Swiss cantons (St. Gallen, Thurgau, Appenzell Innerrhoden and Appenzell Ausserrhoden), *J. Ethnobiol. Ethnomed*. 10 (1): 1–23.
- Eldamaty, H.S.E., Effect of adding nettle leaves (*Urtica dioica* L.) powder on basal diet to lower diabetes in rats (2018). *Egypt. J. Food*. 46: 141 – 151.
- Humphries, D.J. and Reynolds, C.K. (2014). The effect of adding stinging nettle (*Urtica dioica*) haylage to a total mixed ration on performance and rumen function of lactating dairy cows, *Animal Feed Science and Technology*, 189: 72-81.
- Jan K.N., Zarafshan, K. Singh S. (2017). Stinging nettle (*Urtica dioica* L.): a reservoir of nutrition and bioactive components with great functional potential, *J. Food Meas. Charact*. 11: 423–433. DOI 10.1007/s11694-016-9410-4.
- Khanal, D., Tiwari, I., Bastola, R., Upreti, C. (2017). Beneficial effects of stinging nettle supplementation on milk production, *Nepal. Vet. J*. 34: 60–68.
- Kumar, M.R., Puri, S., A. Pundir, Bangar, S.P., Changan, S., Choudhary, P., Parameswari, E., Alhariri, A., Kumar S.M., Damale, R.D., Singh, S., Berwal, M.K., Dhumal, S., Bhoite, A.G., Senapathy, M., Sharma, A., Bhushan B. Mekhemar, M. (2021). Evaluation of nutritional, phytochemical, and

- mineral composition of selected medicinal plants for therapeutic uses from cold desert of Western Himalaya, *Plants*, 10, 1429. <https://doi.org/10.3390/plants10071429>.
- Maaroufi, L., Sazzad-Hossain, M., Tahri, W., Landoulsi, A. (2016). New insights of Nettle (*Urtica urens*): Antioxidant and antimicrobial activities, *J. Med. Plants Res.* 11: 73-86.
- Mihaljev, Ž., Živkov-Baloša, M., Čupić, Ž., Jakaić, Š. (2014). Levels of some microelements and essential heavy metals in herbal teas in Serbia, *Acta Poloniae Pharmaceutica - Drug Research*, 71 (3): 385-391. ISSN 0001-6837.
- Milosevic, B., Omerovic, I., Savic, Z., Andjusic, L., Milanovic, V., Ciric S. (2021). Stinging nettle (*Urtica dioica*) in broiler nutrition, *Worlds Poult Sci J.* 15:1-2. DOI: 10.1080/00439339.2021.1963645.
- Moula, N., Sadoudi, A., Touazi, L., Leroy, P., Geda, F. (2019). Effects of stinging nettle (*Urtica dioica*) powder on laying performance, egg quality, and serum biochemical parameters of Japanese quails, *Animal Nutrition*, 5(4): 410-415.
- Mzid, M., Khedir, B.S., Salem, M.B., Regaieg, W., Rebai, T. (2017). Antioxidant and antimicrobial activities of ethanol and aqueous extracts from *Urtica urens*, *Pharm. Biol.* 55: 775-781.
- Opačić, N., Radman, S., Fabek Uher S., Benko B., Voća S., Šic Žlabur, J. (2022). Nettle cultivation practices-from open field to modern hydroponics: A case study of specialized metabolites, *Plant*, 11, 483. <https://doi.org/10.3390/plants11040483>.
- Otwinowska-Mindur, A., Migdał, Ł., Kmiecik, M., Wojtyśiak D. (2021). Effect of a Diet Supplemented with Nettle (*Urtica dioica* L.) or Fenugreek (*Trigonella foenum-graecum* L.) on the Post-Slaughter Traits and Meat Quality Parameters of Termond White Rabbits. *Animals*, 11, 1566. <https://doi.org/10.3390/ani11061566>.
- Pandey, A.K., Kumar, P., Saxena, M.J. (2019). Feed Additives in Animal Health. In *Nutraceuticals in Veterinary Medicine*; Gupta, R.C., Srivastava, A., Lall, R., Eds.; Springer: Cham, Switzerland, 345–362.
- Pant V. (2019). Himalayan Stinging Nettle: Rich Source of Protein and Minerals. *J Ethnobiol Tradit Med Photon.* 130:1532-1548. DOI: 10.13140/RG.2.2.29576.44801;
- Pant, V., Sundriyal R.C. (2016). Nutritional and therapeutic efficacy of stinging nettle -A review, *J Ethnobiol Tradit Med.* 126:1240-1254.
- Paulauskienė A. Tarasevičienė Ž., Laukagalis, V. (2021). Influence of Harvesting Time on the Chemical Composition of Wild Stinging Nettle (*Urtica dioica* L.), *Plants*, 10, 686. <https://doi.org/10.3390/plants10040686>.
- Rafajlovska, V., Kavrakovsk, Z., Simonovska, J., Srbinoska, M. (2013). Determination of protein and mineral contents in stinging nettle, *Quality Of Life*, 4(1-2):26-30.
- Said, A.A.H., Otmani, I.S.E., Derfoufi. S., Benmoussa, A. (2015). Highlights on nutritional and therapeutic value of stinging nettle (*Urtica dioica*), *Int. J. Pharm. Sci.* 7: 8-14.
- Shonte, T.T., Duodu, K.G., Henriette, L., de Kock, Effect of drying methods on chemical composition and antioxidant activity of underutilized stinging nettle leaves, *Heliyon*, 6 e03938. <https://doi.org/10.1016/j.heliyon.2020.e03938>
- Singhal, K.K. and Thakur, S.S. (2005). Herbal Feed Additives. In: Kundu, S.S., Mohanta, S.K., Singh, S. and Pathak, P.S. (Ed) *Animal Feed Technology*. Satish Serial Publishing House, Delhi, India. 181-192
- Thakur, S.S. and Mahesh M.S. (2015). Effect of feed supplements, minerals and vitamins on animal production. In book: Gopal Sankhala, N. Balasubramani, H. R. Meena, R. Chakravarty, B. S. Meena, and Khajan Singh (Eds.) 2015. *Enabling Extension Functionaries to Address Field Level Problems in Animal Husbandry in compendium of All India Animal Husbandry Officers' Workshop-2015*, 60-69.

- Upton, R. (2013). Stinging nettles leaf (*Urtica dioica* L.): extraordinary vegetable medicine, *J. Herb. Med.* 3(1): 9-38.
- Velciov, A., Popescu, S., Riviş, A., David, I., Gogoşă, I. (2015). The evaluation of some bioelements in different types of herbal teas and their infusions, pp. 863-870, 15th International Multidisciplinary Scientific Geoconference, Ecology and Environmental Protection Section, vol I, Albena, Bulgaria, 2015, ISBN 978-619-7105-39-1, ISSN 1314-2704, DOI: 10.5593/sgem2015B51.
- \*\*\*Regulamentul (CE) nr. 183/2005 al Parlamentului European și al Consiliului din 12 ianuarie 2005 d. In Document de orientare referitor la punerea în aplicare a unor dispoziții ale Regulamentului (CE) nr. 183/2005 de stabilire a cerințelor privind igiena hranei pentru animale (2019/C 225/01)

---

---





## PROTECTION SYSTEMS AGAINST LATE SPRING FROSTS IN PERMANENT CROPS

Vjekoslav TADIĆ<sup>1\*</sup>, Davor PETROVIĆ<sup>1</sup>, Petra MIŠKULIN<sup>2</sup>, Goran PAČAREK<sup>1</sup>,  
Ivan VIDAKOVIĆ<sup>1</sup>, Željko BARAČ<sup>1</sup>

\*E-mail corresponding author: vtadic@fazos.hr

<sup>1</sup>University of Josip Juraj Strossmayer in Osijek, Faculty of Agrobiotechnical Sciences in Osijek,  
Department for Agricultural Engineering and Renewable Energy Sources, Vladimira Preloga 1,  
31000 Osijek, Croatia

<sup>2</sup>MSc student of Agricultural Engineering, University of Josip Juraj Strossmayer in Osijek,  
Faculty of Agrobiotechnical Sciences in Osijek

### ABSTRACT

*The appearance of late spring frosts due to climate changes causes' great damage to orchard – viticulture production. The main aim of the paper was to study and process all methods of protecting permanent plantations from late spring frosts. The causes and occurrence of frost, as well as measures and methods of suppressing negative effects are explained. Protection methods are divided into three most important: active, passive and chemical measures. The methods that are in the domain of agricultural engineering are explained in detail, because researches show that they are the most effective: using a sprinkler by slow raining; direct heating (stationary furnaces and mobile heat generators), fans for air mixing. Among the other possibilities, the methods with smoking and covering of permanent crops still show some effectiveness. Domain of protection of permanent crops regarding late spring frost, due to climate change, will become more pronounced, and agricultural engineering must keep up with the challenges of modern production and give an answer to all challenges.*

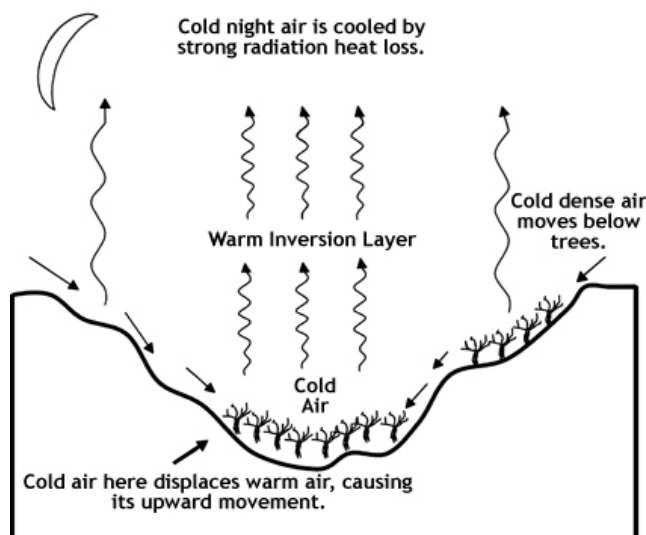
**Keywords:** *spring frost, permanent crops, sprinkles, heating, fans*

### INTRODUCTION

At the end of the last century and the beginning of this one, the planet Earth began to heat up intensively due to increased emissions of CO<sub>2</sub> into the atmosphere (Kyoto Protocol, 1997; Paris Agreement, 2015; COP26, 2022), and as a result, weather extremes became more and more common. With weather disturbances due to the instability of the atmosphere during flowering and the early growth of orchards and vineyards, the occurrence of late spring frosts,

which destroys flower buds and young shoots at the beginning of the growing season, has become more frequent. Considering the mentioned changes, agricultural engineering for protecting permanent crops from late spring frosts got greater importance in the intensive fruit and viticulture production. As temperature extremes became more expressive, different forms of late spring frosts were described in the literature.

Pfammatter, W. (1998) states that three types of frost generally occur: a) Advection frost - occurs when a large amount of cold air stays in one area for a long time; b) Evaporation frost - freezing due to water evaporation which can slightly lower the temperature of young plant parts and cause damage. An increase in relative humidity and a decrease in air temperature can lead to the appearance of "evaporation ice"; c) Radiation frost - soil behaves like a dark body and on clear and quiet nights it loses heat due to radiation, warm air rises, and cold air descends and freezing follows. Due to the intense occurrence of frosts, Cittadini et al. (2006) state that the assessment of the risk of frost damage is important in planning the development of new orchard areas and deciding on the design and construction of frost protection systems. Figure 1 shows occurrence of late spring frosts.



Source: Taylor, K. C. (2012)

**Figure 1** Occurrence of late spring frosts

Late spring frosts in moderate climate zones have emerged as one of the most dangerous production problems, as even one night below freezing point can result in complete production failure. In this zones, the appearance of frost lasts less and occurs more often than in other climates (Bagdonas et al., 1978). In tropical climates, there is usually no freezing except at higher altitudes. Therefore, when tropical crops are damaged by cold, the temperature is usually above freezing (Snyder and Melo-Abreu, 2005).

Lee et al. (2018) state in their research that a numerical model was developed to predict the growth of the frost layer based on computational fluid dynamics. This model can predict

the growth behaviour of the porous frost layer formed by desublimation. The model was validated by experimental results in different operating conditions and was used to analyse the growth process of the frost layer.

As a result of low temperatures, plant tissue is destroyed as a result of the formation of ice crystals within the cell. Depending on the duration of the cold and the plant phenophase, plant resistance to negative temperatures increases. Late spring frosts in moderate climate zones occur in April and even in May when many crops are starting to develop or are already in full development. That is why it is necessary to know the microclimate, in order to avoid orchard or vineyard planting in areas where spring frosts are bound to occur. Due to mentioned, every farmer must choose the most suitable method according to his possibilities, efficiency and economy (Bugarin et al., 2014).

In their paper, Atam and Arteconi (2017) clarify the concept for a new field of application of multifunctional photovoltaic systems: electricity production combined with the prevention of freezing of large apricot groves in a region of Turkey. The produced electricity from the photovoltaic system will be used to air heating and to direct him to the apricot trees.

Bugarin et al. (2014) divides protection against late spring frosts into three areas: a) passive protection - selection of terrain for plantations, avoiding field works before the danger of frost has passed, maintenance of soil without weeds whose transpiration lowers the ground temperature, selection of cultivars with later flowering and selection guidance in this direction, finding varieties resistant to low temperatures); b) active protection - covering plants with different materials, use of smoke and fog with combustion and foggers, use of different sprinkler systems, direct heating with various types of stoves, air flow produced by large fans, heating with infrared radiation; c) chemical protection based on the use of hormones to slow down flowering and vegetation. In practice, of all forms of protection against frost, three active methods are used the most: light raining, direct heating and creating air currents with large diameter fans. In the following, only active measures will be reviewed as the most effective methods of protection. Figure 2 shows the occurrence of late spring frost.



Source: <https://www.jabuka.tv/wp-content/uploads/2019/04/mraz-slana-led.jpg>

**Figure 2** Late spring frost

## PROTECTION BY COVERING PLANTS

By canning, the heat during the night is concentrated near ground where plant parts are most sensitive to frost, so covering is the simplest method of protection. Plants can be protected by covering with straw, peat, cardboard, fabrics or by applying chemical products such as porous foam, plastic film or artificial snow. The problem of this method is its limitation with regard to large production areas. It gives good results if the temperatures are not lower than  $-3^{\circ}\text{C}$ . It consists in preventing radiation (Bugarin et al., 2014). Fuller et al. (2003) conducted research on the application of hydrophobic particles and acrylic polymer as frost protection. In freezing tests, the application of a film of hydrophobic particles led to less damage, while the acrylic polymer led to the same amount or more damage compared to control plants. Figure 3 shows use of agrotextile for plant protection.



Source: Miškulin, P. (2020): Bsc thesis

**Figure 3** Agrotextile protection for covering plants

## PROTECTION BY SMOKING OF PERMANENT CROPS

Smoking is the oldest and cheapest protection against frost. The cloud of smoke prevents the emission of heat, thus mitigating the cooling of the ground air layers (Miškulin, P., 2019).

The combustion should be such that it does not develop an intense flame, but a large amount of smoke, which should spread within the entire plantation. This is not the best example of ecology, but in conditions of great need it can help a lot. This method does not increase the temperature, but rather prevents the temperature from falling further. It is not a particularly safe way, but it can prevent the temperature from dropping by  $2^{\circ}\text{C}$  (Bugarin et al., 2014). Materials that create thick smoke are burned in the plantation (manure, sawdust, wet straw mixed with leaves...). For this method to be successful, about 50 fires per hectare are needed. With this method, it is possible to protect the orchard from weaker frosts down to  $-4^{\circ}\text{C}$ . Anti-hail nets, if they have already been installed, can also greatly help in protecting plantations from late spring frosts by smoking. By using them, the smoke manages to stay within the plantations and between the plants themselves for a certain period of time, thus

prolonging the effectiveness of this method of protection. Figure 4 shows smoking of permanent crops.



Source: <https://zvornicki.ba/wp-content/uploads/2017/04/mraz-dimljenje.jpg>

**Figure 4** Smoking of permanent crop

## PROTECTION OF PERMANENT CROPS BY RAINING

The protection is based on the physical phenomenon that when water freezes, heat is released (80 cal/1 gram of water). The released heat keeps the ground temperature above 0°C. Frost protection begins when the temperature drops below 0°C, and is carried out until the air temperature rises above 0°C, that is, until all the ice created on the plantation trees melts (Miškulin, P., 2019). With this method, the ice actually becomes an insulator between the plant parts and the surrounding temperature below 0°C. The release of heat by the freezing of water droplets prevents the temperature in the thin air layer between the vegetative organ and the ice cover that has formed on the plant from being lower than -0.3°C. In order to avoid possible damage, raining should continue even after the temperature rises above zero, until the ice formed on the plants melts completely. This avoids sudden melting of the ice and cooling of the plant, considering that the same amount of heat is consumed during melting, which was released by freezing. The formed drops should be very fine and of small diameter so that the ice forms evenly on the parts of the plants, so that no damage occurs from breaking the branches. A small amount of water can cause the plants to freeze, because an insufficient amount of heat is released, while a large amount can cause damage due to the formation of an abnormally large mass of ice, which causes broken branches. Examples of rain protection show that with apples and pears, effective prevention of freezing up to -6°C is achieved with a water quantity of 2.4 mm h<sup>-1</sup>, that is, with 24 m<sup>3</sup> h<sup>-1</sup> per hectare. Damage from breaking branches due to a large mass of ice was already observed when using a water quantity of 3.2 mm h<sup>-1</sup> (Bugarin et al., 2014).

Considering the amount of water needed for protection, the source of water is mostly reservoir lakes. Centrifugal motor pumps with high flow rates are used, with an operating pressure of 6-8 bar (depending on the terrain configuration). An indicator of successful frost

protection is the appearance of ice on the plants - if the ice is transparent, the protection is going well. If the ice takes on a milky colour, it means that the plants have started to freeze (Figure 5). The main features of this protection method are high efficiency, but also high water consumption (usually one protection lasts 10 hours) (Miškulin, P., 2019).



Source: <https://cdn.agroklub.com/upload/images/image/mgn-tekst.jpg>

**Figure 5** Successful protection by rain (left) and unsuccessful protection (right)

Perry, K.B. (1998) states in his paper that rain protection, along with certain risks, has significant advantages. Operating costs are lower because water is much cheaper than oil and gas. Irrigation systems are convenient to operate because they are controlled by a central housing with a pump. The same author states that rain protection has a multipurpose function; it has the function of drought prevention, heat suppression, fertilizer application and very likely pesticide protection. Method for preventing occurrence of late spring frost with sprinkles and raining is shown at Figure 6.



Source: <https://cdn.agroklub.com/upload/images/text/thumb/slika1-880x495.jpg>

**Figure 6** Frost protection by raining

## PROTECTION BY DIRECT HEATING

Direct heating belongs to efficient methods of protection against frost, it is based on heating the air, and thus sensitive plant parts. By burning different materials, heat is generated and the temperature is maintained above 0 °C. Heating is done by furnaces that radiate heat and heaters with a fan, which provide protection and heating by the flow of heated air. The heated air rises to the temperature protective layer at a height of 5-20 meters and expands. As a replacement for the heated air that rises from the side, cold air meets it, which also warms up and rises even higher. This creates air circulation, warms the plantation and protects plants from freezing. Heating is more economical if the weather is quiet, because otherwise the warm air is carried away quickly, and new amounts of warm air are needed, i.e. higher fuel consumption. Examples of protection by direct heating with stoves show that one stove can effectively protect approximately 40 m<sup>2</sup>. However, more precise researches show that 83,736 J/h per 100 m<sup>2</sup> is needed for frost protection down to a temperature of -5°C. This amount of heat is obtained by burning 3 l of fuel oil or 6 kg of coke, in calm weather, while in strong winds it is 50% more (Bugarin et al., 2014). Portable furnace is shown at Figure 7.



Source: <https://cdn.agroklub.com/upload/images/text/thumb/grijac1-880x495.jpg>

**Figure 7** Using a portable stove for heating

## APPLICATION OF *STOPGEL* CANDLES IN FROST PROTECTION

In order to prevent potential damage due to frost, many agricultural producers use the *StopGEL* anti-frost candles. They very quickly and efficiently raise the temperature in the plantation and thus heats the plantation or areas where vegetables are grown. The candle burns for about 8 hours if used under normal conditions. The large surface area of the candle ensures maximum thermal radiation. The *StopGEL* candle is easy to handle and store, and it is lit with a gas lighter (Miškulin, P., 2019). Table 1 shows required amount of candles per ha depending on expected frost temperature.

**Table 1** Required amount of *StopGEL* candles/ha depending on temperature

Temperature (°C)	-2	-3	-4	-5 do -6	-6 do -7
Number of candles per ha	200	250-300	300-350	350-400	400-500

Source: <https://www.agroklub.com/vinogradarstvo/stopgel-svijeca-zastitite-svoje-vinograde-i-vocnjake-od-mraza/40035/>

The StopGEL candle is lit using a gas lighter for a minimum of 5-7 seconds at the highest intensity. When candle is lightened it is advisable to check the intensity of combustion after 10-15 minutes. If the flame is too weak (flame height 2-5 cm), it is recommended to light it again so that the flame reaches a height of 15-30 cm. Extinguishing the StopGEL candle is very easy, it is enough to put the lid on the bucket. Figure 8 shows the use of StopGel candles.



Source: <https://cdn.agroklub.com/upload/images/image/colic-stopgel-1-1.jpg>

**Figure 9** Lighted *StopGEL* candles in the vineyard

## APPLICATION OF A MOBILE HEAT GENERATOR

The importance of the mobile heat generator (*Frostbuster*) is in the successful mixing of air below and above the inversion layer. By burning propane, heat is created, which the fans spread around the plantation and reduce frost damage. The amount of heat decreases rapidly with the distance from the source, so it is necessary to restore the amount of heat, so this is the limiting factor of this machine because the machine has to return to its initial position within a certain period of time. The heated air from the heater expands, becomes lighter and rises vertically and air turbulence improves heat transfer to the plantation. *Frostbuster* (Figure 10) consists of a burner that burns gas from industrial or household bottles and a fan that disperses heated air over the plantation (540  $\text{m}^3 \text{min}^{-1}$ , min. 40 kW of tractor). The maximum dispersion of warm air is 150 meters in width (working width on both sides). Gas consumption is 30–45  $\text{kg h}^{-1}$ , and the hot air coming out of the machine has a temperature of 80-100°C, while at a distance of one meter from the machine the temperature is around 20°C. Before



using this machine, it is necessary to mark the directions of movement, and the distance between the passages must not exceed 140 meters (usually 70-60 meters).



Source: [http://img.agriexpo.online/es/images\\_ag/photo-g/169270-10789165.jpg](http://img.agriexpo.online/es/images_ag/photo-g/169270-10789165.jpg)

**Figure 10** Mobile heat generator

The advantages of using *Frostbuster* compared to other methods of frost protection are: relatively low purchase price of the machine (plantation area up to 10 ha), low application costs, low maintenance costs, harmless to the environment, less occurrence of diseases compared to rain protection, easy to use and it is very reliable in exploitation (Sito et al., 2014).

### FANS FOR AIR MIXING

This method of protection is based on intensive mixing of air layers, whereby stronger radiation and temperature inversion are prevented. Fans driven by electric motors (Figure 11) with a power of 65-75 kW are placed on height supports, which are higher than the plantation - one fan is required for every 4 to 4.5 ha. During the exploitation of the fan, there is a certain prevention of temperature reduction of 1 to 2°C, so during operation, dew and frost do not occur (Bugarin et al., 2014).

The fans create an air current almost horizontally to mix the warmer air in the temperature inversion with the cooler air near the surface. The fans generally consist of a steel tower with large rotating twin blades (diameter cca. 3 m) located at the top, mounted on a shaft inclined about 7° down from the horizontal in the direction of the tower. The height of the fan is about 10-11 m, and the number of rpm is 590 to 600 per minute. Fans are not recommended when surrounding winds are greater than 2.5 m s<sup>-1</sup> or when there is fog that can cause serious fan damage if the blades freeze.



Source: <https://www.vailmontvineyards.com/7lrg.jpg>

**Figure 11** Fans for creating an air current

Battany, M. C. (2012) in his research discusses the performance of modern updraft fans compared to conventional fans. To answer this hypothesis, experiments were conducted on 12 spring frost nights in 2010 and 2011 in a commercial vineyard operating two fans: an updraft and a single conventional fan. Conventional fan produced consistently greater and statistically significant increases in temperature, particularly at the 1.1 m of vineyard level. Based on the summarized relationships between temperature changes, under inverse gradient conditions of  $0.2\text{ }^{\circ}\text{C m}^{-1}$ , a conventional fan is expected to increase temperatures by  $1.6\text{ }^{\circ}\text{C}$  at vine level.

## CONCLUSION

In this paper, all methods of protecting permanent plantations from late spring frosts are presented, and those that are most often used are studied in detail. At the end it is easy to conclude that there are many modern methods for plantation protection, but farmers mostly use methods that are most accessible and acceptable by price. In the Republic of Croatia, especially on smaller farms, in most cases simpler methods of plants covering and smoking are most often used, while recently, farms have been equipped with different systems for air flow heating and fans exploitation. Stated facts are response of modern agricultural production to climate change and producer's adaptation on increased risks. Therefore, in the future, it is impossible to imagine any form of intensive orchard – vineyard production without the application of modern agricultural engineering to protect permanent plantations from late spring frosts.

## REFERENCES

- Atam, E., Arteconi, A. (2017.): Green Energy-assisted Frost Prevention: A Conceptual Framework. *Energy Procedia*, 141: 155-159.
- Bagdonas, A., Georg, J.C., Gerber, J.F. (1978.): Techniques of frost prediction and methods of frost and cold protection. Geneva, Switzerland. World Meteorological Organization Technical Note, 157: 160.
- Battany, M.C. (2012.): Vineyard frost protection with upward-blowing wind machines. *Agricultural and Forest Meteorology*, 157: 39-48.
- Bugarin, R., Bošnjaković, A., Sedlar, A. (2014.): Agricultural engineering in fruit growing and viticulture. University textbook. University in Novi Sad, Agricultural faculty, Novi Sad, Serbia
- Cittadini, E.D., de Ridder, N., Peri, P.L., van Keulen, H. (2006.): A method for assessing frost damage risk in sweet cherry orchards of South Patagonia. *Agricultural and Forest Meteorology*, 141 (2-4): 235-243.
- Fuller, M.P., Hamed, F., Wisniewski, M., Glenn, D.M. (2003.): Protection of plants from frost using hydrophobic particle film and acrylic polymer. *Annals of Applied Biology*, 143 (1): 93-98.
- Kyoto Protocol, 1997: [https://unfccc.int/kyoto\\_protocol](https://unfccc.int/kyoto_protocol)
- Lee, J., Kim, J., Kim, D.R., Lee, K.S. (2018): Modeling of frost layer growth considering frost porosity. *International Journal of Heat and Mass Transfer*, 126 (A): 980-988.
- Miškulin, P. (2019): Protection systems against late spring frosts in permanent crops. BSc thesis. Faculty of Agrobiotechnical Sciences Osijek, Croatia.
- Paris Agreement, 2015: <https://unfccc.int/process-and-meetings/the-paris-agreement/the-paris-agreement>
- Perry, K.B. (1998.): Basics of Frost and Freeze Protection for Horticultural Crops. *American Society for Horticultural Science*, 8 (1): 10-15.
- Pfammatter, W. (1998.): Lutte contre le gel par aspersion en arboriculture fruitière; *Revue suisse. Vitic.Arboric.Hortic*, 30 (5): 331-335.
- Sito, S., Skendrović Babojelić, M., Šket, B., Vodopivec, J., Šket, M., Kušec, V., Milodanović, M. (2014.): Application of *Frostbuster* in protecting orchards from frost. *Glasnik Zaštite Bilja*, 37 (3): 53-58.
- Snyder, R.L., Melo-Abreu, J.P. (2005.): Frost protection: fundamentals, practice and economics. Food and Agriculture Organization of the United Nations, 1:12-29.
- Taylor, K. C. 2012. Peach Orchard establishment and young tree care. University of Georgia Extension Circular 877.
- UN Climate Change Protocol, Glasgow 2022: <https://ukcop26.org/>

---

---



## INTERACTIVE, MODULATED SYSTEM FOR THE PROTECTION OF VEGETABLE CROPS

Cătălina TUDORA<sup>1\*</sup>, Cristina STROE<sup>2</sup>, Floarea BURNICHI<sup>3</sup>, Adriana MUSCALU<sup>1</sup>,  
Valentin Nicolae VLĂDUȚ<sup>1</sup>

\*E-mail of corresponding author: cmc\_tudora@yahoo.com

<sup>1</sup>National Institute of Research - Development for Machines and Installations Designed for Agriculture and Food Industry - INMA Bucharest, 6 Ion Ionescu de la Brad Avenue, District 1, Bucharest, Romania

<sup>2</sup>National Research and Development Institute for Textiles and Leather - INCDT, 16 Lucrețiu Pătrășcanu, District 3, Bucharest, Romania

<sup>3</sup>Vegetable Research and Development Station Buzau, 23 Mesteacaului St., Buzau, Romania

### ABSTRACT

*Agricultural production depends on weather conditions and, as a result, it is one of the most vulnerable sectors to them. Changes in temperature and precipitation, along with extreme weather and climate conditions, influence crop yields and livestock productivity, which in turn affect agricultural incomes, causing significant economic losses. The main environmental factors under the influence of extreme weather phenomena, which influence germination, growth, flowering, fruits set and ripening are: temperature, water and light. The solutions for combating the effects of climate change are represented by the creation of varieties resistant to thermo-hydric stress, the fight against weeds, diseases and pests in an ecological system, the adaptation of cultivation technologies to the new requirements, including the use of plant shading systems. The effectiveness of protection systems with agrotexile nets has made them increasingly used, having a useful life of approximately 10 years, in terms of the structure resistance, and 4-5 years in terms of the nets.*

*The main objective of this paper is to present an innovative technical solution, represented by an interactive, modulated system, made with agrotexile nets, intended to protect crops against extreme weather phenomena (heat, heavy rains, hail, etc.). The system consists of: the textile system, intended for protective nets for horticulture and the support system. The entire system ensures the protection of vegetable crops located in the open field, ensuring the continuity of production throughout an entire growing season. The paper aims to present the constructive elements of the interactive protection system and the preliminary results obtained in the field on two vegetable crops onion (*Allium cepa*) and French bean (*Phaseolus vulgaris*).*

**Keywords:** climate change, textile system, support system, *Allium cepa*, *Phaseolus vulgaris*.

## INTRODUCTION

In Romania, the losses caused by extreme weather phenomena, as well as the lack of active intervention measures to combat or limit them, represent the main argument in the approach to the agrotexile field. Vegetable crops are generally sensitive to extreme weather, and approx. 60% of the storms that occur between March and September (coinciding with the growing season of crops), are accompanied by hail (Muscalu et. al., 2020). Hail could significantly damage all types of agricultural crops, and in some cases (high and long-lasting intensity), it results with the total depreciation of crops and the destruction of horticultural plantations. Ice crystals break leaves, flowers, and in horticultural plantations, they cause damage to the branches of young shoots, fruits or even take them to the ground. Depending on the phase of plant growth and the type of crops affected, hail can cause not only a decrease in yields, but also a complete loss (Punge et. al., 2014). In the case of vegetable crops in protected spaces, the problem of managing the environmental factors necessary for plant development can be achieved by controlling them. There is the problem of finding textile or plastic materials that can be used in this sense. Shading nets are used to reduce the amount of sunlight entering the protected spaces. The role of the shading net is to reduce the amount of sunlight that enters the greenhouse or solarium, and implicitly to reduce the internal temperature to a level that does not create thermal stress for the vegetables. To manage the thermal regime and the air movement dynamics, the shading nets can be diversified, by cumulating requirements. Also, the shading net can be designed in such a way as to protect the plants from birds, insects and hail. The very high temperature and the high degree of brightness during in the summer, period results with high economic damage, generated in particular by fruit abortion, but also by the high percentage of fruits spoilage sensitive to the sunscald (e.g. pepper). Agrotexile nets have positive effects on the growth of vegetables, but according to several researchers, they have negative effects on the dry matter and chemical composition of vegetables (Marasovic and Kopitar, 2019).

The sector of technical textiles is an example of a “traditional sector” capable of “redefining its identity” according to a new business model, adapted to the needs of the new industrial revolution (smarter, inclusive and sustainable). Technical textiles “are textile materials and products made primarily for their technical properties and performance, more than for their aesthetic and decorative qualities” (Cârpuș et. al., 2014). There are 12 large classes of technical textiles, one of them being textiles for use in agriculture (AgroTech - agrotexiles). The global agrotexiles market size in 2020 was valued at \$9.05 billion and is expected to grow at an annual growth rate of 4.7% from 2021 to 2028. Increasing demand for higher quality agricultural products is expected to drive an increase in crop productivity for the forecast period, with a positive impact on the growth of the global agricultural market (Grosu et. al., 2020; Kopitar et. al., 2022). Agrotexile products can be woven, non-woven or knitted. They offer solutions for the variety of problems in the agro-food industry, thanks to the advantages they have as textile structures: flexibility, resistance, light weight, protection (Orth et. al., 2018). Various assortments of simple and/or chemical filament yarns, natural fibre yarns (jute, wool, sisal, flax, hemp, coconut) are used to make agrotexiles (Sharma et.al., 2022). In the category of natural fibres, jute is the most used, due to its functional properties but also its biodegradable character, later serving as soil fertilizer. Agrotexiles based on natural fibres represent one of the most popular alternatives of the agrotexile group, with a thriving market representing approximately 8.2% of the total volume and 6.4% of the value of the world textile market (Palamutcu et. al., 2017). The basic functional requirements of

agrotexile products are weather and microorganism resistance. For the design of agrotexiles, synthetic fibres are the best solution, and PP (polypropylene) and PE (polyethylene) are the most commonly used. The fibres/yarns used to make agrotexiles must ensure certain functionalities of the final product, their characteristics being presented in table 1.

**Table 1** Fibre - agrotexile product characteristics

<b>Fibre characteristics (required)</b>	<b>Agrotexile characteristics (expected)</b>
Strength and elongation at break	Long-term durability and long service life
Resistance to solar radiation	Long-term durability and long service life
Resistance to ultraviolet radiation	Light permeability 80 - 90%
Biodegradability	Biodegradation in nature
Abrasion resistance	Long-term durability and long service life
Protection	Protection against the wind and the creation of a suitable climate
Resistance to microorganisms	Resistance to microorganisms
Dimensional stability	Stability regardless of application
Low weight	Easy to use
Resistance to toxic agents	Long-term durability and long service life

## MATERIAL AND METHODS

The interactive, modulated system for the protection of vegetable crops consists of:

- **System of textile structures** – made of knitted net, using as raw materials: polypropylene (PP), polyethylene (PE), polyester (PES), polylactic acid (PLA). The textile structures were made by warp knitting technology, resulting in 3 structures, which represented the experimental variants.
- **Support system** for agrotexile nets consisting of: support poles; main and secondary ropes; anchors; rope tensioners; pole caps; pole clamps; rope fixing clamps; net joining clips.

The experiments with onion cv. "de Buzau" and French bean cv "Doina" under field conditions were established at Vegetable Research-Development Station (SCDL) Buzau. Four experimental variants (with two repetitions) were tested: V1 - POS (white net with single mesh), V2 - POD (white net with double mesh), PU 30% - shading net, V4 - unshaded control variant.

Tested nets were evaluated through the productivity of vegetable species grown, expressed as onion bulbs yield (kg m<sup>-2</sup>) and the number of French bean pods at two harvests made on July 13 and 27, 2020.

**System of textile structures** of architectural element-type with a covering membrane, which has a protective role, made of knitted structure with semi-stiffening ribs, which provides various assemblies with a removable joint, provided with fixing and stretching elements. To create the multifunctional modules, the knitted net textile structures were designed from yarns with high resistance to mechanical stress. The knitted net structure was obtained by warp knitting technology. The properties of textile materials depend on the type of fibres used in their production and the manufacturing conditions (Ajmeri, 2016; Calin et. al., 2020). Textile nets must withstand solar radiation and various temperatures, be effective in climate change, and create a microclimate between soil and agrotextile to balance temperature and humidity, reducing soil and environmental pollution (Ajmeri, 2016; Böttjer et. al., 2019). As textile raw materials, indicated in the production of net-type membranes are:

**Polypropylene (PP)** - thermoplastic, semi-crystalline, non-biodegradable polymer obtained from petroleum resources. Used in the textile field, standard polypropylene is presented in the form of monofilament, polyfilament and short fibres.

**Polyethylene (PE)** - thermoplastic, semi-crystalline polymer with excellent chemical resistance, fatigue and wear resistance, with a wide range of properties. In the textile field, PE is presented in the form of filament yarns. It is lightweight, stain resistant and has low moisture absorption rates.

**Polyester (PES)** - category of polymers containing the ester functional group in their main chain. Polyester is a petroleum-based synthetic fibre, being the most used fibre. Depending on the chemical structure, polyester can be a thermoplastic or thermosetting material. Polyester fibres have high tenacity, are elastic, have low water absorption and minimal shrinkage compared to other fibres.

**Polyactic Acid (PLA)** - biodegradable and bioactive thermoplastic aliphatic polyester derived from renewable biomass, typically consisting of fermented starch (corn, cassava, sugar cane or sugar beet pulp). It has similar characteristics to PP, PE or polystyrene (PS).

The textile membranes used are the net type with rhomboidal meshes and were obtained by warp knitting technology, with additional yarns. Two types of textile yarns were used:

- the background yarns, which by knitting generate the shape of the net and ensure the transmission of loads in the membrane of the architectural element (module), so that the statics of the textile architectural element is ensured, together with the tensioning, fixing, support systems;
- the additional yarns, which by knitting generate the surface elements, ensuring the diffuse reflection of the light.

The characteristics and performances of agrotextile nets aim at the following:

Performance features:

- fibre composition: 100% technical polyester;
- yarn fineness: 5-100 tex for background/net yarns and 10-200 tex for additional yarns;
- yarn structure: multifilament yarns, with the observation that the additional yarns must be physically-mechanically textured to give them volume.

Physical-mechanical characteristics:

- color: if the architectural element is intended for weather protection, then white fibres can be used so that the cost price is minimal. If it is intended to manage the process of



plant growth and development, then yarns of certain colours can be used, but the price is high;

- the specific weight is min.  $40 \text{ g m}^{-2}$ , and by using additional systems this can increase;
- the mechanical potential defined as a multiple of the tensile loads of the component yarns, is completed by the tensional response that appears in the net nodes.

According to the concept of technical textiles, these are high-performance materials with high durability, which increase the productivity and quality of agricultural products. They are a component part of some groups of textile structures with a protective role, which help to solve the increasing challenges faced by the agricultural sector, because of the changes in climatic conditions (Chowdhury et. al., 2017). To create the multifunctional modules used in agriculture, the textile structures of knitted net were designed from yarns with high resistance to mechanical stress. The knitted net structure is obtained by warp knitting technology. The knitted panels were reinforced on the edges with textile strips and provided with fasteners. The shape of the covering membrane was obtained by assembling several modules. A membrane has an opening that is in close correlation with the dimensions of the furrows, according to the technology for vegetable cultivation.

**Support system** for agrotexile nets (Fig. 1 and Fig. 2) consists of: support poles; anti-hail net; main rope; secondary rope; anchor; rope tensioner; pole cap; pole clamp; rope fixing clamp; net joining clip. Considering the planting schemes, it is necessary to ensure a protection zone that allows the movement of machines to perform soil tillage and the fitting of an optimal number of furrows between the pole rows.

*The support poles (1)* have the role of supporting the system of ropes (main and secondary) on which the *agrotexile net (2)* is fixed. The pole cap and the pole clamp are mounted on the pole. Spruce or pine wood is used as material, impregnated with a preservative (Tanalith E), which provides long-lasting protection.

*The main rope (3)* is mounted on the ends of the poles located along the longitudinal direction of the plot, in the slots provided in the pole caps. At one of the ends of pole rows, the main rope is passed through the eye of the anchor, through the pole clamp, and then it is fixed with a clamp. At the other end, the main rope is passed through the eye of the anchor, through the tensioner fixed on the pole clamp, and after stretching, it is fixed with the clamp. It is of multifillar cable type with a diameter of 6 mm, made of galvanized steel and covered with plastic.

*The secondary rope (4)* is mounted on the ends of the poles located in the transverse direction of the plot, in the slots provided in the pole caps. It is of multifillar cable type with a diameter of 5 mm, made of galvanized steel and covered with plastic.

*The anchor (5)* ensures a solid support for stretching the ropes and is provided with a welded helical plate to be fixed in the ground and is made of galvanized steel with a diameter of 14 mm.

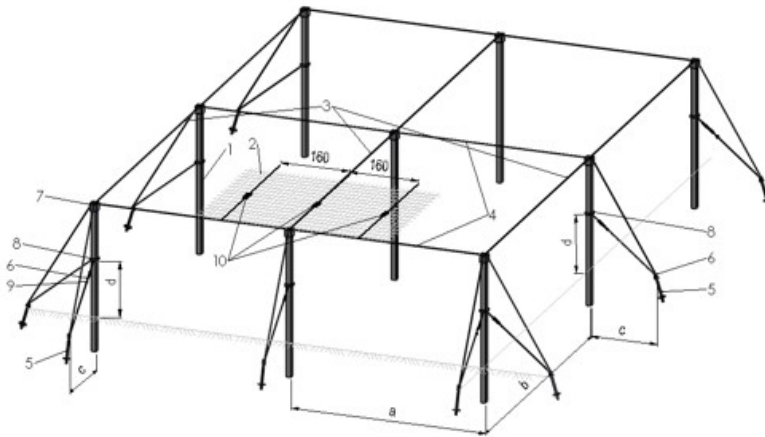
*The rope tensioner (6)* is mounted on the pole clamp, and it helps to stretch and tension the ropes, both the main and the secondary one.

*The pole cap (7)* is mounted in the upper part of the pole, it is provided with an element for fixing the anti-hail net and with channels for guiding the ropes, both the main and the secondary ones. It is made of high-density PP, with an inner diameter of 10 cm, equal to the diameter of the pole.

The pole clamp (8) is mounted on each perimeter pole, ensuring the fixing of the end of the rope to the pole, being made of galvanized steel and having an inner diameter equal to the diameter of the pole.

The rope fixing clamp (9) ensures the fixing of the ends of the ropes, both the main and the secondary ones, being made of galvanized steel.

The net joining clip (10) has the role of fixing the agrotextile net on the main ropes as well as of joining the net panels in the longitudinal direction. The clamp is made of high density polypropylene.



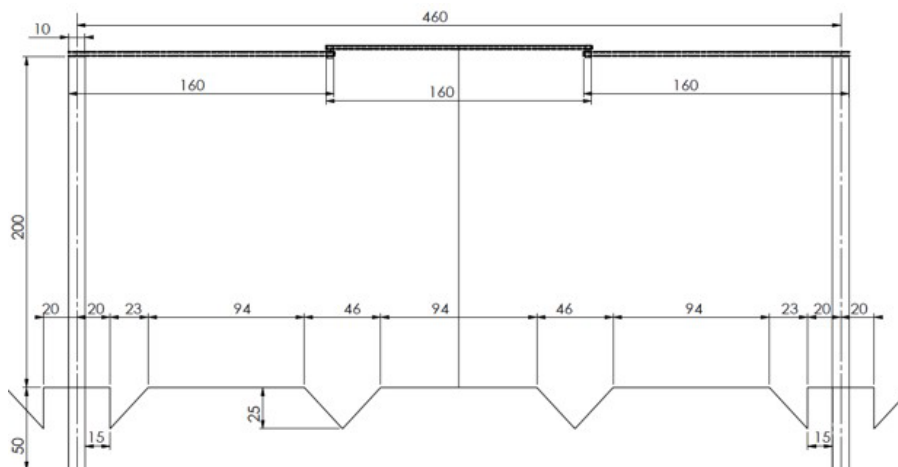
**Figure 1** Scheme of the support system for the agrotextile nets  
 (1) support poles; (2) agrotextile net; (3) main rope; (4) secondary rope; (5) anchor; (6) rope tensioner; (7) pole cap; (8) pole clamp; (9) rope fixing clamp; (10) net panels joining clip.

Figure 2 shows details of the Support system for agrotextile nets, related to the way the support poles are fixed to the ground.



**Figure 2** Detail of the support system for agrotextile nets

Considering the constraints imposed by the planting schemes of the two crops (onion and French bean) and taking into account ensuring the possibility of crop rotation, mechanized soil tillage and ensuring the conditions for discharging hail accumulations (in case of massive falls), without endangering the crop plants, it is necessary to establish some requirements both in terms of distance between the pole rows and regarding the width of the anti-hail net (Fig. 3).



**Figure 3** Establishing the distance between the pole rows and the width of the agrotexile net in relation to the planting scheme

To determine the distance between the poles rows, consider:

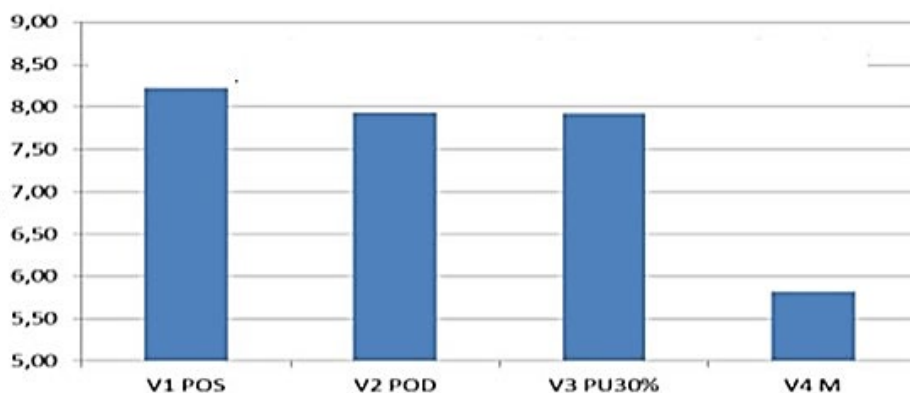
- the specific planting scheme for each vegetable crop (land modelled in furrows raised by 94 cm at the top and 1.40 m wide, 2 rows being planted/sown, with a left-right free zone of 12 cm;
- a protection zone to be provided relative to the pole rows, located along the longitudinal direction of the plot, which allows the movement of working aggregates to perform the basic soil works and soil modelling;
- fitting a whole number of furrows between the pole rows;
- the distance between the pole rows in the longitudinal direction of the plot is 4.6 m.
- To determine the width of the agrotexile net, consider:
  - the distance between the pole rows along the longitudinal direction of the plot;
  - the width of the furrows where the crops are placed is 1.40 m;
  - the possibility of unloading the ice accumulated on the anti-hail net between the furrows in the event of massive falls;
  - the losses in the useful width of the net, as a result of the net panels joining by clamps and its fixing on the main rope;
- This results in a width of at least 1.6 m for the agrotexile net.

## RESULTS AND DISCUSSION

The interactive, modulated protection system with agrotexile nets was intended to ensure the protection of vegetable crops (onions and French bean) located in the open field, against extreme phenomena, thus ensuring the continuity of production throughout an entire growing season. It includes:

The study of the agrotexile net protection system effects on two vegetable crops (onions and French bean) was carried out in the agrometeorological conditions of 2020 at SCDL Buzau. The average temperature varied between: 16 to 18 °C in May, while in August temperatures were >30 °C. Precipitations, were deficient during the entire growing season, with increased cloudiness in July and August).

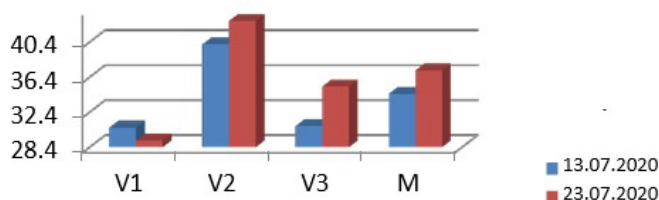
As can be seen from the data presented in Fig. 4, the highest onion yield (>8 kg m<sup>-2</sup>) was obtained under V1-POS net, compared with the other three variants under study. Also, good results were obtained under V2-POD and V3-PU30% nets, with productions a little bit below 8 kg m<sup>-2</sup>. Achieved yield under all three experimental variants being to the open field, uncovered control (5.80 kg m<sup>-2</sup>).



**Figure 4** Onion bulb production, (kg m<sup>-2</sup>)

In fig. 5 it can be seen that the highest pods number per plant at both harvests was obtained for V2-POD treatment (39 pods/plant on July 13 and 40 pods/plant on July 23, while the lowest pods number per plant was obtained for V1-POS (30 pods/plant on July 13 and 28 pods/plant on July 23). This means that the shading with the white net with double mesh had a beneficial effect on the pods production of pods, especially at the second harvest, the one made in the third decade of July.

The study conducted by Calin et. al., in 2020, regarding the effect of textile materials of different colours on pepper culture grown in the field and in greenhouse, showed differentiated values of the anthocyanin and chlorophyll content, depending on the climatic conditions and the colour of the agrotexile material used for covering/shading.



**Figure 5** The number of pods/plant in Field beans (*Phaseolus vulgaris*)

Shahak et. al. (2016), in their study, report that while blue shade nets slow vegetative growth and induce leaf dwarfing in ornamentals and cut flower crops, red and yellow nets stimulate vigour and vegetative growth. Of these two, the yellow one has repeatedly outperformed the red net in its stimulating effects. In sweet pepper, both shading nets (yellow and red) determined the increase in productivity, but the yellow net additionally reduced the fungal decay of fruits before and after harvest, the effect also leading to increased accumulation of antioxidants (Selahle et. al., 2015).

Tosic et.al. (2019), on their study, report that geotextile and agrotexile had a major impact on the most frequently examined parameters of lettuce (reduction of nitrate level, the Zn content was significantly higher than in plastic mulches treatments, a positive effect on the vitamin C content).

## CONCLUSIONS

The high effectiveness of protection systems with agrotexile materials has made them be increasingly used in recent years.

From a constructive point of view, the interactive, modulated system for the vegetable crop protection consists of 2 parts: the agrotexile net and the support system. It was made considering the planting schemes for two vegetable crops, onion and French bean.

The obtained results showed that shading with agrotexiles (with double mesh) had a beneficial effect on the productions obtained, especially during the second harvest. For future vegetable production (in culture technology), it is recommended to use the interactive, modulated protection system.

## ACKNOWLEDGMENTS

This work was supported by a grant of the Romanian Research and Innovation Ministry, through Programme 1 - Development of the national research-development system, sub-programme 1.2 - Institutional performance - Projects for financing excellence in RDI, Contract no. 16PFE.

This work was supported by the NUCLEU Programme, carried out with the support of ANCSI, Project PN 23 04 02 05, Contr. 9N/01.01.2023 - "Innovative technology for the superior utilization of inflorescences and seeds of medicinal plants".

## REFERENCES

- Ajmeri, J. R. Ajmeri, C. J. (2016). *Developments in Nonwovens as agrotextiles*. Woodhead Publishing Limited in association with The Textile Institute, Cambridge, 365-384.
- Böttjer, R., Storck, J. L., Vahle, D., Brockhagen, B., Grothe, T., Herbst, S., Dietz, K.J., Rattenholl, A., Gudermann, F., Ehrmann, A. (2019). Influence of textile and environmental parameters on plant growth on vertically mounted knitted fabrics. *Tekstilec*, 62, 200-207.
- Călin, M., Dorogan, A., Cărpuș, E., Cristea, T.O., Ambăruș, S., Brezeanu, C., Brezeanu, P. M., Iosob, G. A., Muscalu, P.S., Calara, M., Bute, A., Prisecaru, M. (2020). The influence of some cover materials on the chlorophyll and anthocyanin content of sweet pepper protected crops. *Biological studies and research, "Vasile Alecsandri" University of Bacau*, 29(1), 53-56.
- Cărpuș, E., Scarlat, R., Visileanu, E., Ene, A., Mihai, C. (2014). Technical textiles - priority development direction of the textile-clothing sector. *AGIR Bulletin* 4, 60-645.
- Chowdhury, M. J., Nasrin, S., Faruque, M. A. A. (2017). Significance of Agro-Textiles and Future Prospects in Bangladesh. *European Scientific Journal ESJ* 13(21), 139.
- Grosu, C., Stroe, C., Sarbu, T., Burnichi, F., Muscalu, A., Tudora, C. (2020). Design and creativity in the field of agro-textiles. *Agriculture & Food* 8, 107-119.
- Kopitar, D., Marasovic, P., Jugov, N., Schwarz, I. (2022). Biodegradable Nonwoven Agrotextile and Films -A Review. *Polymers* 14, 2272.
- Marasovic, P., Kopitar, D. (2019). Overview and perspective of nonwoven agrotextile. *Textile & Leather Review* 2(1), 32-45.
- Muscalu, A., Tudora, C., Coța, C., Gyorgy, Z., Burnichi, F., Birsan, M. (2020). Climate changes and methods to protect vegetable crops. *E3S Web of Conferences TE-RE-RD 2020* 180, 03016.
- Orth, M., Müller, K., Becker, A., Bergmann, M., Mattheß, J., Gries, T. (2018). Innovative ecological agricultural textiles. *International Polymer Science and Technology* 45(7), 291-296.
- Palamutcu, S., Devrent, N. (2017). Technical Textiles for Agricultural Applications. *International Interdisciplinary Journal of Science Research* 3, 1-8.
- Punge, H. J., Bedka, K. M., Kunz, M., Werner A. (2014). A new physically based stochastic event catalog for hail in Europe. *Natural Hazards* 73(3), 1625-1645.
- Selahle, K. M., Sivakumar, D., Jifon, J., Soundy, P. (2015). Postharvest responses of red and yellow sweet peppers grown under photo-selective nets. *Food Chemistry* 173, 951-956.
- Shahak, Y., Kong, Y., Ratner, K. (2016). The wonders of yellow netting. *Acta Horticulturae* 1134, 327-334.
- Sharma, N., Allardyce, B., Rajkhowa, R., Adholeya, A., Agrawal, R. (2022). A Substantial Role of Agro-Textiles in Agricultural Applications. *Frontiers in Plant Science* 13, 895740.
- Tosic, I., Miroslavljevic, M., Przulj, N., Trkulja, V., Pesevic, D., Barbir, J. (2019). Effect of geotextile and agrotextile covering on productivity and nutritional values in lettuce. *Chilean journal of agricultural research* 79(4), 523-530.



## AUTOMATED SPRAY MIXTURE APPLICATION PROCESS IN THE "REBULA" VARIETY VINEYARD

Peter BERK<sup>1\*</sup>, Andreja URBANEK KRAJNC<sup>1</sup>, Mario LEŠNIK<sup>1</sup>, Andrej PAUŠIČ<sup>1</sup>, Denis STAJNKO<sup>1</sup>, Peter VINDIŠ<sup>1</sup>, Damijan KELC<sup>1</sup>, Miran LAKOTA<sup>1</sup>, Aleš BELŠAK<sup>2</sup>, Tomaž POJE<sup>3</sup>, Viktor JEJČIČ<sup>3</sup>, Mojca MAVRIČ ŠTRUKELJ<sup>4</sup>, Simona HAUPTMAN<sup>5</sup>, Marko BREZNIK<sup>5</sup>, Marko HOČEVAR<sup>6</sup>, Matej SEČNIK<sup>6</sup>

\*E-mail of corresponding author: peter.berk@um.si

<sup>1</sup>Department of Biosystems engineering, University of Maribor, Faculty of Agriculture and Life Sciences, Pivola 10, SI-2311 Hoče, Slovenia

<sup>2</sup>Department of Mechanical Engineering Design, University of Maribor, Faculty of Mechanical Engineering, Smetanova 17, SI-2000 Maribor, Slovenia

<sup>3</sup>Agricultural Institute of Slovenia, Department of Agricultural Technology and Energy, Hacquetova 17, SI-1000 Ljubljana

<sup>4</sup>KGZS, Agricultural Forestry Institute Nova Gorica, Pri hrastu 18, SI-5000 Nova Gorica

<sup>5</sup>KGZS, Agricultural Forestry Institute Maribor, Vinarska 14, SI-2000 Maribor

<sup>6</sup>Department of Energy Engineering, Faculty of Mechanical Engineering, Aškerčeva 6, SI-1000 Ljubljana, Slovenia

### ABSTRACT

*In the process of applying the plant protection product mixed with water (spray mixture) with conventional Air Blast Sprayers to the grapevine in the prescribed concentration for chemical protection, standard models are used to express plant protection product dosage rate, which are not taken into account characteristic properties of the green leaf wall area of the grapevine. The result of such models is uncontrolled amount of the spray mixture through individual nozzles to the leaf wall area. In the research work, we present an automated modular system, which enables controlled spray mixture dosage rate through the nozzles onto different segments of the leaf wall area and was tested in May 2022. An automated axial Air Blast Sprayer prototype was equipped with an automated modular system, which enabled pulse width control of the spray mixture. The autonomous (continuous duty cycle control (DC: from 0 to 100%)) and conventional (nozzle fully open all the time) operation mode was tested at a constant Air Blast Sprayer operating travel speed of 5.5 km h<sup>-1</sup>. The amount of spray mixture, expressed as a percentage between autonomous and conventional Air Blast Sprayer operation mode was evaluated. The maximum saving of spray mixture through an individual nozzle (68.00 %) was estimated in the phenological phase BBCH 16.*

**Key words:** *algorithm, spray mixture, control, automation, dosage rate, grapevine*

## INTRODUCTION

It is necessary to ensure adequate protection of the yield against various diseases, pests and weeds for good quality and yield of the grapes in the vineyard. Yield protection can be carried out in several different ways, among which chemical protection with plant protection product (hereinafter PPP) is the most important. When protecting the yield with various chemicals, we try to eliminate harmful organisms and prevent infections, whereby one part of the amount of PPP remains on the yield and the other one finds its way into the immediate environment. PPP residues can cause contamination of soil, groundwater, air, plants and animals, which represents a big problem in modern agriculture in viticulture production. We cannot solve the problems that have arisen overnight, namely by returning to the old way of cultivation or to organic production, without using PPP, therefore, for stable and sustainable grape production, it is necessary to ensure the reduction of harmful effects on the environment in which we live. Thus, the modern method of production in viticulture will be the only alternative in the future, where we will have to take environmental aspects into account. Therefore, we will have to apply smaller amounts of PPP, which are dangerous for the environment, given the fact that, that we will have to maintain the same quality of grape protection in the vineyard. This can be ensured by precise application of spray mixture, which we will apply in real time to the green leaf area of the grapevine through powerful automated modular systems (Campos et al., 2020; Miranda-Fuentes et al., 2015).

The development and expansion of digitization in the agricultural economy in the organization of grape production requires new viticultural practices, which refer to the precise process of applying the spray mixture to the green leaf area. In the process of applying PPP in the prescribed concentration with conventional Air Blast Sprayers for chemical protection of grapevine canopies standard models are used to express PPP doses according to characteristic properties. The result of such models is uncontrolled distribution of the spray mixture through individual nozzles to the grapevine canopy (Chen et al., 2019; Salcedo et al., 2020; Zhu et al., 2008).

In the literature review, we present an overview of the development of alternative spray mixture application techniques that researchers have used in vineyards, whereby we focused on works describing various automated Air Blast Sprayer. The modular systems work on the basis of algorithms (decision-making models for controlling spray mixture dosage rate), with them, the researchers simplified the dosage control process, and captured information about the natural structure of the canopy, which was measured with electronic measuring systems (ultrasound, visual, photogrammetry, laser...). Classical decision-making models work on the basis of software algorithms, through which they can control the dose rate of the spray mixture, namely in the ON/OFF mode of operation (Giles et al., 1989; Balsari and Tamagnone, 1998; Doruchowski et al., 1998; Stajnko et al., 2012). At the beginning of the development of the decision-making models, the control of spray mixture doses was carried out via electromagnetic valves (hereinafter EMV), however, they worked on the basis of information that represented the measured values of the distance between the ultrasonic sensor and the object (tree canopy). The information fed to the inputs of the decision-making models affects the process (on and off EMV) of control of dosages. In addition to the decision models



that operate in ON/OFF mode, there are models that allow the control of dosage rate based on three levels or discrete states. These are: maximum dosage rate, minimum dosage rate and no dosage rate (Molto et al., 2001). The most precise modular systems for controlling the amount of spray mixture doses are represented by systems that work in a continuous mode of operation. The continuous mode of operation based on the measured characteristic properties (volume, leaf area, cross-section of the crown, number of point clouds...) of the grapevine canopy enables continuous control of the dosage rate in the range from 0 to 100 %. At the output of the decision-making model, control signals are generated that enable the control of dose rate through the EMV in the continuous range from 0 to 100 % (Solanelles et al., 2006; Escolà et al., 2007; Chen et al., 2012; Butts et al., 2019; Salcedo et al., 2020; Grella et al., 2021).

In the research work we present our own approach of an automated modular system for precise application of spray mixture on different grapevine canopy segments. The modular system is based on LIDAR measurements and digital reconstruction of grapevine canopy. DGPS system for measuring the speed and position of the movement trajectory and smart control module calculate the amounts of spray mixture dosage rate on different segments of the grapevine canopy. We made a comparative analysis of the consumption of spray mixture between the conventional and the automated mode of operation of the Air Blast Sprayer and assessed the level of disease at harvest in the vineyard and estimate an economic calculation of PPP savings.

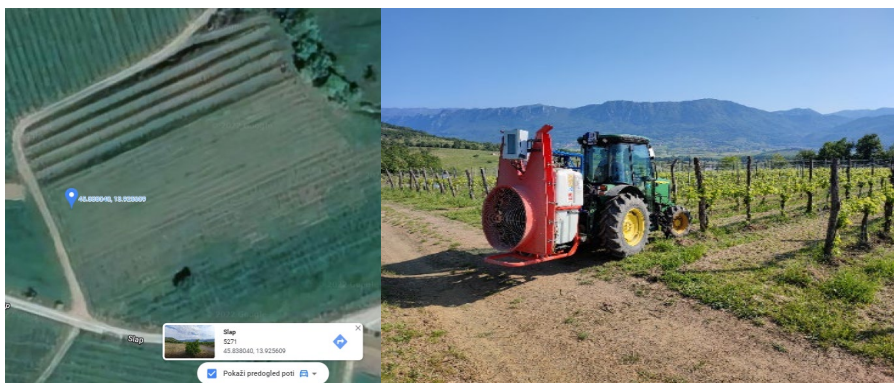
## MATERIAL AND METHODS

For experimental purposes, we used the vineyard of the agricultural holding Urban Petrič, Vipava, Slovenia. The area of the vineyard for the experiment was 2000 m<sup>2</sup>, the location of the experiment is 45°50'16.9" N, 13°55'32.2" E (Figure 1, left). In the intensive vineyard, grafted grapevine of "Rebula" variety at the age of 6 years, are planted on the basis of SO4. The SO4 base behaves well in various soils, including calcareous ones, and affects the early and good maturation of wood. The base is used in individual wine-growing regions of Slovenia and was selected according to professional criteria. The inter-row distance between seedlings is 230 cm and the upbringing form is single-spawning (spar with up to ten eyes) with a plug (one to two eyes on the plug), where the height of the grapevine stem is 70 cm and the average distance between the grapevines is 92 cm. We observed the grape variety "Rebula" BBCH16, BBCH57, BBCH63 and BBCH71 phenological phase (Lorenz et al., 1995). We tested two different modes of operation of the prototype Air Blast Sprayer during the regular spraying of the vineyard, which for experimental purposes was enabled to operate in conventional and autonomous mode.

### *Air Blast Sprayer AGP 300 EN*

A tractor-mounted Air Blast Sprayer AGP 300 EN for the uniform application of drops of spray mixture was applied in the experiment. The Air Blast Sprayer is a modern machine consisting of: a supporting frame with a chemically resistant polyethylene tank and a pouring sieve, a pump, a pressure and flow regulator, a suction filter, a pressure filter, three-way valves, a mixing nozzle and an air blower. In the case of Air Blast Sprayer types with the suffix EN, an additional tank for cleaning the Air Blast Sprayer after the application of PPP and a tank with clean water for washing hands is built into the main tank. A standard blower with an axial fan in a Ø 825 mm diameter casing enables the direction of the air flow during

the mixture droplets application process and adjustable air capacity. In axial fans, air enters and exits in the direction of the axis of rotation of the fan. It is made in the form of a propeller with several blades, the angle of which can be gradually changed. The air flow of the fan is soft because it does not have a high exit speed, so it does not tear plant parts. The task of the fan is to create an air flow to carry spray mixture drops from the nozzle to a certain place - the grapevine canopy.



**Figure 1** Design of an experiment to optimize the process of applying spray mixture in a permanent vineyard plantation.

### ***Automated modular electronic measurement and control system***

A modular electronic measurement and control system (installed on a conventional type of mounted tractor Air Blast Sprayer AGP 300 EN, manufacturer Agromehanika, Kranj) was used for the digital evaluation of the green leaf area and automated control of dose rate (by individual nozzle, Figure 1, right). The automated modular system consists of three main components. The first one consists of laser (LIDAR) measurement technology, which is installed on a special carrier of a tractor-mounted Air Blast Sprayer. We digitally determined the density of the green leaf wall area at different phenological stages of the grapevine on individual segments of the grapevine canopy. In the experiment, we used a laser sensor manufactured by SICK, Germany, model LMS111. The SICK LMS111 laser distance meter offers an IP67 protection standard, which means that it is also suitable for outdoor use in the vineyard. LMS 111 enables data capturing with 50 Hz frequency an angular resolution of  $0.5^\circ$  with a range of 20 m. Data transfer takes place in real time via an Ethernet interface with a nominal speed of 100 Mbit/s. The configuration and operation of the LMS111 sensor is based on sending messages (telegrams) between the laptop and the LMS111 sensor using the time-of-flight measurement concept of measuring the interval of time that passes between the transmission of a light pulse and the receipt of the light signal reflected from the green leaf area.

The second component of the automated modular system is a microcontroller with an added Ethernet module that takes care of transferring measurements from LIDAR measurement technology and automated control of spray mixture dosage rate in pulse width mode via work cycles, through which the three-way EMV are controlled in real time.

The third component represents the DGPS measuring system, which allows to determine the driving speed and the location of the automated modular measuring system to the nearest few centimeters. The location and speed of the autonomous modular system were determined at a frequency of 10 Hz. We used the latest DGPS system from UBLOX, receiver model F9P. The system enables dual-frequency GPS signal reception with RTK correction. The system consists of two parts. We installed a DGPS reference station for correcting the pseudo distances of the GPS receiver in the field close to the vineyard. The correction data were transmitted to the mobile station (mounted on the tractor) via a data link in real time, demodulated and then used to correct the GPS data.

### ***Electromagnetic valves***

The EMV control frequency over duty cycles was 10 Hz. We used the Teensy 3.6 microcontroller with a built-in 32-bit 180 MHz ARM Cortex-M4 processor, which offers enough processing power to process data from LIDAR measurement technology and control spray mixture dosage rates via EMV in real time. HYPEX FKM MQ control valves (3/2 NC-valve with 3 connections on the housing, rated coil power 7 W) were used to control the spray mixture doses on the four segments of the grapevine canopy. We installed them on a modified sprinkler armature with an inlet and outlet port in the housing and a vent port on top of the magnet sleeve. The operation of the control EMV took place in direct mode, which means that in the case of a direct supply voltage of 12 V, which is supplied to the electromagnetic coil of the valve, the open state of the EMV is enabled. Control EMV typically open at a pressure of 0 bar. The EMV normally operate at a maximum working pressure of 10 bar, which directly depends on the nominal diameter of the valve seat and the electrical power consumption of the coil. Due to the limited electrical power, which in our case was 7 W, the EMV does not allow for larger quantity flow rate of spray mixture.

### ***Spray nozzles and PPP amount control***

The Air Blast Sprayer is equipped with classic ALBUZ ATR 80° vortex nozzles (SOLCERA DANS LE MONDE, Evreux, France) with a hollow cone jet. The basic task of the nozzles is to disperse the liquid stream of the spray mixture into a jet with a certain spectrum of droplets and direct it to the green leaf area, where the spray droplets are deposited so that the spray mixture is distributed as evenly as possible over the leaf area. According to the nozzle manufacturer, the exit angle of the nozzle jet is 80°, which means that our types of nozzles are used for high-pressure spraying of orchards and vineyards at pressures from 8 to 15 bar. In the experiment in the vineyard, we set the working pressure to 10 bar, so the flow through the nozzle was 1.03 L min<sup>-1</sup>.

In the 2022 season, we carried out four regular spray mixture treatments and in real time digitally evaluated the size of the density of the green leaf area through the digital number of points in the cloud, namely for the left and right half of the grapevine canopy. Based on the principle of autonomous capture of measurements via laser LIDAR measurement technology and an automated modular system, we have enabled the digital evaluation of the density of the leaf area of the grapevine in this way, (Berk et al., 2021). The information on the estimated value of the density of the leaf area was used in a decision-making model (fuzzy logic algorithm), which later, in the optimization of the spray mixture application process, enabled the control of spray doses in the range from 0% to 100%, (Berk et al., 2019). For the analysis of the quantities of spray mixture dosage rate 8 individual rows of the vineyard was selected. Namely, in 4 individual rows we implemented the conventional mode of operation and in the

remaining 4 individual rows, the automated mode of operation. In our experiment we implemented the conventional spraying program (Table 1) for controlling diseases (downy mildew and grapevine oidium). Based on the principle of an automated modular system, which included digital measurement of the density of the green leaf area, an automated module for controlling the amount of spray mixture doses and the DGPS measurement system, we carried out optimization of the consumption of the amount of spray mixture doses in the conventional and autonomous mode of operation in the vineyard. We compared the amount of spray mixture used, expressed as a percentage, between the automated and conventional mode. Through regular spraying, we obtained data regarding the impact of automated spray application on the occurrence of disease (the degree of attack on leaves and grapes expressed in percentages) and on the height and quality of the yield in the vineyard with the conventional cultivation form and made an economic analysis of the savings of PPP's in EUR.

## RESULTS

In the 2022 growing season, we carried out a total of 4 sprayings (Table 1). The automated modular system worked through advanced laser LIDAR measurement technology and a control system that, through an algorithm (decision-making model), enables the continuous control of spray mixture dosage rates, according to the density of the green leaf wall area by individual segments of the grapevine canopy. Through the DGPS navigation measurement system, we made it possible to measure the speed of the carried automated Air Blast Sprayer prototype, which affected the consumption of dosage rates and the quality of the application of spray mixture droplets.

**Table 1** The spraying program used to control diseases in the vineyard during the regular spraying season, year 2022

Vineyard location	Spraying program	Date of spraying
Urban Petrič farm	Cuprablau Z 35 WP: 1 kg ha <sup>-1</sup>	May 10, 2022
Urban Petrič farm	Micrithiol Special: 2 kg ha <sup>-1</sup> , Cuprablau Z 35 WP: 1 kg ha <sup>-1</sup>	May 25, 2022
Urban Petrič farm	Micrithiol Special: 2 kg ha <sup>-1</sup> , Cuprablau Z 35 WP: 1 kg ha <sup>-1</sup>	June 3, 2022
Urban Petrič farm	Micrithiol Special: 2 kg ha <sup>-1</sup> , Cuprablau Z 35 WP: 2 kg ha <sup>-1</sup>	June 13, 2022

Table 2 shows the results of consumption of dosage rate amounts on individual segments of the canopy with automated and conventional mode of operation of the prototype Air Blast Sprayer. In the conventional mode of operation, the Air Blast Sprayer nozzle was continuously open throughout the optimization of the spray mixture application process. To optimize the spray application process, we used a different number of nozzles, which were calibrated according to the height of the green leaf area of the grapevine and at an angle to ensure a uniform distribution of the jet with drops of the spraying, which were evenly distributed over the green leaf area. We made a thorough analysis of the effectiveness of the

two methods of operation (conventional and automated) as well as an analysis of the success of disease control for both methods of operation and made an economic analysis.

**Table 2** Comparative analysis between conventional and autonomous mode of operation of the Air Blast Sprayer prototype, year 2022

<b>Spray mixture saving [%], right side of the Air Blast Sprayer</b>										
Spraying	Date	Application time [s]		Nozzle PWM				Sum of savings L ha <sup>-1</sup>	Amount PWM L ha <sup>-1</sup>	Amount CON L ha <sup>-1</sup>
		PWM*	CON	1	2	3	4			
1	10 May 2022	309.80	262.52	67.0	x	x	x	32.73	16.12	48.85
2	25 May 2022	254.18	276.78	34.0	13.0	x	x	22.96	74.74	97.70
3	3 June 2022	575.02	499.34	26.0	14.0	17.0	56.0	55.20	140.22	195.42
4	13 June 2022	256.70	263.78	9.0	4.0	11.0	61.0	41.53	153.89	195.42
Total								<b>152.42</b>	<b>384.97</b>	<b>537.39</b>

<b>Spray mixture saving [%], right side of the Air Blast Sprayer</b>										
Spraying	Date	Application time [s]		Nozzle PWM				Sum of savings L ha <sup>-1</sup>	Amount PWM L ha <sup>-1</sup>	Amount CON L ha <sup>-1</sup>
		PWM	CON	1	2	3	4			
1	10 May 2022	309.80	262.52	68	x	x	x	33.20	15.60	48.85
2	25 May 2022	254.18	276.78	3	12	x	x	7.33	90.37	97.70
3	3 June 2022	575.02	499.34	25	14	19	59	57.16	138.26	195.42
4	13 June 2022	256.70	263.78	9	4	14	67	45.92	149.50	195.42
Total								<b>143.61</b>	<b>393.73</b>	<b>537.39</b>

\*PWM - pulse width modulation, CON - conventional

Table 3 shows the results of the disease assessment, the spray experiment (conventional and automated mode of operation), the degree of attack on leaves and grapes expressed in percentages. For each measurement, we performed 400 evaluations (4x100 randomly selected leaves or grapes) in the vineyard. According to the given analysis, we concluded that there were no significant differences in disease control between the conventional and autonomous mode of operation.

**Table 3** Results of disease occurrence assessments – data on the quantity and quality of the yield, year 2022

<b>Illness and appointment</b>	<b>Application of preparations without the use of a sensor</b>	<b>Application of preparations using a sensor</b>
<b>First assessment: August 8, 2022</b>		
Downy mildew on leaves	0.2200 a	0.2600 a
Downy mildew on grapes	0.0825 a	0.0875 a
Oidium on the leaves	1.2825 a	1.2950 a
Oidium on grapes	0.2825 a	0.2950 a
<b>Second evaluation: September 23, 2022</b>		
Downy mildew on leaves	2.1300 a	2.5200 a
Downy mildew on grapes	0.7550 a	0.8875 a
Oidium on the leaves	3.1300 a	3.1800 a
Oidium on grapes	1.0650 a	1.0900 a
Gray mold on grapes	2.1250 a	2.0250 a
<b>Yield parameter</b>		
Amount of yield (kg ha <sup>-1</sup> )	3739.3 a	3611.5 a
Sugar level Brix °	19.350 a	20.225 a
Total titratable acids (g L <sup>-1</sup> )	4.222 a	3.975 a

Tukey HSD test used ( $p < 0.05$ ). If the letters are the same, there is no significant difference for the parameter.

Table 4 shows the results of the analysis of the economic calculations of the PPP savings between the conventional and the automated process of applying the spray mixture in the vineyard.

During the spraying season (year 2022), we used a different number of nozzles on the left and right half of the Air Blast. At the beginning of the growing season (developmental stage BBCH 16), we used two nozzles, namely one nozzle on the left and one on the right side, and estimated a saving of spray mixture to 65.93 L ha<sup>-1</sup> compared to the conventional spraying method. In the middle of the growing season (developmental stage BBCH 71), we used eight nozzles, namely four nozzles on the left and right side, and estimated a saving of spray mixture of 87.45 L ha<sup>-1</sup> compared to the conventional spraying method. The total saving of spray mixture for the four processes of spray application in 2022 was 296.03 L ha<sup>-1</sup>, whenever the mounted tractor Air Blast Sprayer AGP 300 EN (nozzle type: Albus ATR 80°, flow rate: 1.03 L min<sup>-1</sup>, working pressure: 10 bar) was used in the experiment. In the 2022 season, we evaluated the assessment of diseases, quantities, quality of the yield and the economic analysis of the calculation of the PPP's savings in EUR on selected vines in the vineyard. We

evaluated the disease assessment between August and September 2022 and found that there were no significant differences between the autonomous and conventional mode of operation. When analyzing the quantity and quality of the grape harvest, we did not observe any significant differences between the conventional and the autonomous method of optimizing the spraying mixture application process. We found out that with four processes of applying the spray mixture in the vineyard, the total savings of PPP's amounted to 50.43 EUR ha<sup>-1</sup>.

**Table 4** Total PPP savings estimated in EUR

<b>Total PPP savings left side of Air Blast Sprayer</b>						
<b>Date of treatment</b>	<b>PPP</b>	<b>Nozzle 1, savings PPP [EUR]</b>	<b>Nozzle 2, savings PPP [EUR]</b>	<b>Nozzle 3, savings PPP [EUR]</b>	<b>Nozzle 4, savings PPP [EUR]</b>	<b>Together according to the nozzle [EUR]</b>
10 May 2022	Cuprablau	6.16				6.16
24 May 2022	Microthiol	1.53	0.58			2.11
	Cuprablau	1.56	0.59			2.16
3 June 2022	Microthiol	0.58	0.31	0.38	1.26	2.54
	Cuprablau	1.19	0.64	0.78	2.57	5.19
13 June 2022	Microthiol	0.30	0.13	0.37	2.05	2.86
	Cuprablau	0.414	0.18	0.51	2.81	3.91
						<b>24.96</b>
<b>Total PPP savings right side of Air Blast Sprayer</b>						
<b>Date of treatment</b>	<b>PPP</b>	<b>Nozzle 1, savings PPP [EUR]</b>	<b>Nozzle 2, savings PPP [EUR]</b>	<b>Nozzle 3, savings PPP [EUR]</b>	<b>Nozzle 4, savings PPP [EUR]</b>	<b>Together according to the nozzle [EUR]</b>
10 May 2022	Cuprablau	6.16				6.16
24 May 2022	Microthiol	1.35	0.54			1.89
	Cuprablau	1.38	0.55			1.93
3 June 2022	Microthiol	0.56	0.31	0.42	1.32	2.63
	Cuprablau	1.15	0.64	0.87	2.71	5.37
13 June 2022	Microthiol	0.30	0.13	0.47	2.26	3.17
	Cuprablau	0.41	0.18	0.64	3.08	4.32
						<b>25.49</b>
<b>Savings (EUR) per ha between 10 May and 13 June/ 1 ha</b>						
Total savings (EUR) per ha between 10 May and 13 June / 1 ha:						<b>50.43</b>
Total savings per area (7 ha) / EUR:						<b>353.02</b>
Amount for spraying conventional method in EUR / 1 ha:						<b>86.70</b>

## CONCLUSIONS

Alternative techniques for optimizing the process of applying the spray mixture working on the principle of electronic measuring systems for detecting the characteristic properties of the grapevine canopy represent one of the most important processes in meeting the nature conservation, economic and safety requirements of healthy grape production. We found that the automated modular system significantly affects in the earlier development stages of the grapevine the application of the dose rate control process itself and directly affects the pulse width control of the EMV, thereby enabling a more selective dosing of the spray mixture on individual segments of the grapevine canopy.

The past research works in the field of alternative techniques for applying spray mixture have shown that by detecting the characteristic properties of the canopy based on various electronic measurement systems and the use of decision models to control the amounts of spray mixture dosages, we cannot always ensure the precise targeted application of spray mixture to the entire structure of the density of the green leaf area of the grapevine canopy. Namely because of the nozzles, which are fixedly installed at the individual heights of the Air Blast Sprayer prototype set. Therefore, in the near future, more attention should be focused on an effective alternative technique of spray application, with which we will enable the dynamic movement of the nozzles and the deposition of spray drops at a constant distance from the grapevine canopy.

## ACKNOWLEDGEMENTS

The paper was prepared within the EIP project "TPGUNT" (Introduction of new mechanical and autonomous automated technologies for sustainable grape production in vineyards, Decision No: 33117-3002 / 2018/10), co-financed by the Ministry of Agriculture, Forestry and Food "Agency of the Republic of Slovenia" for agricultural markets and rural development, in connection with the Decree on the implementation of the cooperation measure from the Rural Development Program of the Republic of Slovenia for the period 2014-2020 and the Public Call for sub-measure 16.2 Support for pilot projects and development of new products, practices, processes and technologies.

## REFERENCES

- Balsari, P., Tamagnone, M. (1998). The necessity to determine the correct amount of air to use in airblast Air Blast Sprayer. Paper 98-A-075. In Proc. Intl. Conf. Agric. Eng. Aas, Norway: Norges Landbrukshoegskole, NLH.
- Berk, P., Urbanek Krajnc, A., Stajanko, D., Vindiš, P., Kelc, D., Lakota, M., Belšak, A., Poje, T., Sečnik, M. (2021). Digital evaluation of the green leaf wall area of the grapevine in the "yellow muscat" variety. 48th International symposium Actual tasks on agricultural engineering, Zagreb, 2nd - 4th March 2021. Zagreb: University of Zagreb, Faculty of Agriculture, Department of Agricultural Engineering, pp. 151-159.
- Berk, P., Stajanko, D., Hočevar, M., Malneršič, A., Jejčič, V., Belšak, A. (2019). Plant protection product dose rate estimation in apple orchards using a fuzzy logic system. PloS one. April 2019, no. 4, vol. 14.



- Butts, T., Butts, L. E., Luck, J. D., Fritz, B. K., Hofman, W. C., Kruger, G. R. (2019). Droplet size and nozzle tip pressure from a pulse-width modulation Air Blast Sprayer. *Biosystems Engineering*, 178, pp. 52–62.
- Campos, J., Gallart, M., Llop, J., Ortega, P., Salcedo, R., Gil, E. (2020). On-farm evaluation of prescription map-based variable rate application of pesticides in vineyards. *Agronomy*, 10(1), 102.
- Chen, L., Wallhead, M., Zhu, H., & Fulcher, A. (2019). Control of insects and diseases with intelligent variable-rate Air Blast Sprayers in ornamental nurseries. *Journal of Environmental Horticulture*, 37(3), pp. 90–100.
- Chen, Y., Zhu, H., Ozkan, H. E. (2012). Development of a variable-rate Air Blast Sprayer with laser scanning sensor to synchronize spray outputs to tree structures," *Transactions of the ASABE*, 2012.
- Doruchowski, G., Jaeken, P., Holownicki, R. (1998). Target detection as a tool of selective spray application on trees and weeds in orchards. *SPIE Conference on Precision Agriculture and Biological Quality*, Boston, ZDA, November 1998, pp. 290–301.
- Escolà, A., Camp, F., Solanalles, F., Llorens, J., Planas, S., Rosell, J. R., Gràcia, F., Gil, E., Val, L. (2007). Variable dose rate Air Blast Sprayer prototype for dose adjustment in tree yields according to canopy characteristics measured with ultrasonic and laser LIDAR sensors. *Proceedings ECPA-6th European Conference on Precision Agriculture*, pp. 563–571.
- Giles, D. K., Delwiche, M. J., Dodd, R. B. (1989). Air Blast Sprayer Control by Sensing Orchard Yield Characteristics: Orchard Architecture and Spray Liquid Savings," *Journal of Agricultural Engineering Research*, vol. 43, pp. 271–289.
- Grella, M., Gioelli, F., Marucco, P., Zwertvaegher, I., Mozzanini, E., Mylonas, N., Nuyttens, D., Balsari, P. (2021). Field assessment of a pulse width modulation (PWM) spray system applying diferent spray volumes: duty cycle and forward speed effects on grapevines spray coverage. *Precision Agriculture*, <https://doi.org/10.1007/s11119-021-09835-6>.
- Lorenz, D.H., Eichhorn, K.W., Bleiholder, H., Klose, R., Meier, U., Weber, E. (1995). Growth Stages of the grapevine: Phenological growth stages of the grapevine (*Vitis vinifera* L. ssp. *vinifera*)—Codes and descriptions according to the extended BBCH scale. *Australian Journal of Grape and Wine Research* 1 (2), pp. 100-103.
- Miranda-Fuentes, A., Rodríguez-Lizana, A., Gil, E., Agüera-Vega, J., Gil-Ribes, J. A. (2015). Influence of liquid-volume and airflow rates on spray application quality and homogeneity in super-intensive olive tree canopies. *Science of the Total Environment*, 537, pp. 250–259.
- Molto, E., Martin, B., Gutierrez, A. (2001). Pesticide loss reduction by automatic adaptation of spraying on globular trees. *Journal of Agricultural Engineering Research*, pp. 35–41.
- Salcedo, R., Zhu, H., Zhang, Z., Wei, Z., Chen, L., Ozkan, E., et al. (2020). Foliar deposition and coverage on young apple trees with PWM-controlled spray systems. *Computers and Electronics in Agriculture*, 178, 105794.
- Solanalles, F., Escolà, A., Planas, S., Rosell, J. R., Camp, F., Gracia, F. (2006). An Electronic Control System for Pesticide Application Proportional to the Canopy Width of Tree Yields. *Biosystems Engineering*, 95, vol. 4, pp. 473–481.
- Stajanko, D., Berk, P., Lešnik, M., Jejčič, V., Lakota, M., Štrancar, A., Hočevar, M., Rakun, J. (2012). Programmable ultrasonic sensing system for targeted spraying in orchards. *Sensors*, vol. 11, pp. 15500–15519.
- Zhu, H., Zondag, R. H., Derksen, R. C., Reding, M., & Krause, C. R. (2008). Influence of spray volume on spray deposition and coverage within nursery trees. *Journal of Environmental Horticulture*, 26(1), pp. 51–57.

---

---



## EFFICIENCY OF ALTERNATIVE WEED CONTROL WITH MECHANICAL SYSTEMS IN THE VINEYARD

Damijan KELC\*, Denis STAJNKO, Miran LAKOTA, Peter VINDIŠ, Jurij RAKUN, Erik RIHTER, Peter BERK

\*E-mail of corresponding author: damijan.kelc@um.si

<sup>1</sup>University of Maribor, Faculty of Agriculture and Life Sciences, Pivola 10, 2311 Hoče, Slovenia

### ABSTRACT

*In the presented study the efficiency methods of weed control in the vineyard under 'Sauvignon' vines were investigated. The purpose of the experiment was to test mechanical systems for controlling weeds in the vineyard with the aim of reducing the use of glyphosate in viticulture. The aim was also finding the most effective weed control combination and compared it with fuel consumption and carbon footprint. The experiment took place at vineyard producer Mr. Vinko Šerbinek, Svečina. Interexport d.o.o. lent Tractor Fendt 211 F Vario (82 kW) with the mechanical systems of a manufacturer Braun Maschinenbau GmbH. Mechanical systems included a grass cutter ('Lama') and a combination of a rotating star hoe (roll hoe, RH) and a vine trunk cleaner (finger hoe, FH). Processing time and the current fuel consumption during work in l/h while driving up and down of the slope was measured. At the end of the row in the vineyard, the tractor records the average consumption in l/h and calculates the total amount of fuel used in l/ha. Footprint and CO<sub>2</sub> emissions was calculated with the help of the program SPI on Web. Statistical analysis was made for calculation between the evaluated parameters of fuel consumption and a processing time. Mechanical treatments resulted in lower weed cover, when using a grass cutter ('Lama') and a combination of rotary hoe + finger hoe. A grass cutter ('Lama') was found to be less efficient in comparison with a combination of rotary hoe (RH) and finger hoe (FH), but on the other hand it has lower footprint. Fuel consumption is slightly lower when using 'Lama'. The measurements and the data suggest that a combination of rotary hoe and finger hoe for weed control in the vineyard could be recommended.*

**Keywords:** *alternative weed control, mechanical systems, weeds, fuel consumption, vineyard, ecological footprint*

## INTRODUCTION

Weed control in vineyards is essential to allow optimal vines development. Manzone et al. (2020) tested weed control on three different techniques (hoeing, chemical control, and mulching) in a vineyard located in Canelli, Italy. They found out that the use of mulching machine and the boom sprayer permits to maintain a weed coverage lower than 30% independently of slope gradient. The hoeing, characterized by low operational costs, scored acceptable weed control, but, in case of heavy rains, it can cause a runoff of the soil. The chemical weed control, is not a valid solution from the environmental point of view. The mulching machine, although shows higher operating costs compared to other machines tested, can be considered as the most acceptable alternative to chemical weed control, because its working efficiency is comparable to that obtained by the sprayer (Manzone et al., 2020).

New "Green deal" of EU policy is aimed to reduce the use of pesticides for agricultural production. Herbicide glyphosate is the symbol of chemical agriculture, used for the most frequent weed control practice. EU policy wants to ban glyphosate in the near future (Antier et al., 2020). Mechanical weed control requires more energy consumption, working time is longer, erosion risks and the use of more expensive attachments. Economic and environmental aspects of different weed control techniques are important (Tamagnone et al., 2011). Shrestha et al. (2013) found in the research that the time required to hoe mechanically cultivated plots was generally lower than the other treatments. Steam and herbicide only suppressed weeds for 2–3 weeks, and the time needed to hoe plots in these treatments was generally similar to the untreated control at all sampling dates. The mechanical treatments also were two to four times more cost-effective than steam or herbicide. Therefore, mechanical treatments were the most effective and economical weed control methods, though none of the treatments affected vine growth, midday stem water potential, petiole nitrate concentration at bloom, grape yield, or quality (Shrestha et al., 2013).

Three different systems of mechanical weed control was compared. Winegrowers need new, effective tools to control weeds. Chemical control prices rise over the past year and are no longer an affordable weed control technique. EU governments also want to ban glyphosate in the future.

## MATERIAL AND METHODS

Mechanical control methods carried out with three different tractor attachments from BRAUN Maschinenbau GmbH: a grass cutter (llama), a rotating star hoe (roll hoe) and a vine trunk cleaner.

### *Vineyard*

The experiment was conducted in the vineyard of the agricultural farm Vinko Šerbinek located in Plač, northwestern Slovenia. The size of the vineyard experiment area was 2000 m<sup>2</sup>, the GIS location of vineyard was 46°40'10.2" N, 15°35'57.7" E. Vines of cultivar 'Sauvignon' grown in an intensive 16-year old vineyard plantation were grafted on Kober 5BB rootstock. The height of vine stocks stem was 0.7 m and plants were fixed in vertical trellis and trained according to standard unilateral Guyot with single-spawning (spar with up to ten buds) with a plug (one to two buds on the plug). In the past, weed management underneath the vines was

always done by application of glyphosate based herbicides and by mulching the grass strip between the vine rows.

The slope in the vineyard is about 8%. The length of the rows is 98 m, the distance between the rows is 2.35 m. The vines are planted at 0.8 m. The area of 230 m<sup>2</sup> is processed in one run of the tractor. The operation date was 24.3.2022. Tractor speed with cruise control is fixed at 5 km/h for FH+RH and 4 km/h for Lama. The used tractor was Fendt 211 F VARIO (82 KW). The tractor measures the current fuel consumption during work in l/h and at the end of work records the average consumption in l/h and calculates the total amount of fuel consumed in l/ha. Time is measured in seconds to process one row.

### ***Statistics***

Fuel consumption, time consumption, footprint, CO<sub>2</sub> emissions were presented by means and standard errors and were statistically evaluated by one-way analysis of variance (ANOVA). Significant differences ( $P < 0.05$ ) between the mean values of each mechanical weed control were determined using the post hoc Duncan test. Significant differences ( $P < 0.05$ ) are indicated by different letters (Table 1, 2). IBM SPSS Statistics 25 (New York; USA; 2017) was used for statistical analysis.

## **RESULTS AND DISCUSSION**

### ***Tools for alternative mechanical weed control***

Three Braun tools (Figure 1 a, b) to control weeds was used. Namely the Braun LUV Perfect grass trimmer (ploughshare blade undercutter; locally called Lama), rotating wheel or star hoe tiller and trunk cleaner mounted on side of mulcher. The Braun LUV Perfekt trimmer is used for efficient and environmentally friendly cultivation in the vineyard, to cultivate a strip of soil underneath the vines. In fact the blade undercuts and lifts the weed and turf cover and facilitates loosening of soil. Ploughshare trimmer was mounted at the side of tractor attached in the middle bracket with two hydraulic cylinders that allow the transverse movement of the tool in a row near the vine. This bracket is integrated on the left and right bracket for various tools (working elements). Above the working element – the grass trimmer, there is a sensor – a mechanical lever which is movable in parallel with respect to the grass trimmer. When bumping into a trunk of a vine or tree or bumping into a pillar the mechanical lever activates the control valve and the hydraulic cylinder moves grass trimmer away from these obstacles. Two hydraulic connections for operation, pressure and return line was needed. In front of the grass trimmer, a plate is also placed on a fixed bracket, which cuts the ground or grass. On the frame lifting system is also mounted, which with a hydraulic cylinder allows precise adjustment of the vertical position of the working element. The working deep was between 5 and 8 cm. For tool operation (grass trimmer) the oil flow was 7 to 12 Lmin<sup>-1</sup>. Grass trimmer cuts the roots of the weeds in the row area of the vineyard. Its undercutting is effective in dry conditions when the undercut plants dry out. In case of high humidity or rain, cut plants quickly "take hold" (root) back.

Another weeding tool was the rotating star hoe called in German Rollhacke (Figure 1 b) used for loosening the soil along the vine and for mechanical weed control in the row space. It enables fast and environmentally friendly work. The principle of operation is the same as by disc plates. The circular star perch has two star plates, the teeth of these stars are curved. These teeth scrape small grooves from the surface during rolling. Compared to disc plates,

circular star hoes achieves good performance even at low operating speeds (from 4.5 km<sup>-1</sup> onwards). It does not leave a flat cutting edge, which significantly reduces the risk of water erosion of the slope. The inclination angle of the working elements is adjusted without tools, only by selecting the appropriate hole on the bracket. There are as many as 43 of these holes. The advantages of this tool are precise vertical lifting, changing settings without tools, efficient operation at low and high working speeds, reduced risk of erosion, easy handling, large range for tilt angle adjustment plates and environmentally friendly work.

The third tool was hydraulic driven vine trunk cleaner Braun RP W1 mounted on side of Braun Alpha sensorthronic mulcher with primary function to remove water shoots – suckers from vine trunk. Rotating rubber paddles on single rotating shaft (30 cm long) cut away weeds and mulch them. In our case mulched stripe was 20 cm wide belt on each side of vine trunk.



**Figure 1** Braun tools for control of weeds underneath vines in the vineyard  
**a)** LUV Perfect grass trimmer - ploughshare undercutter mounted on side of tractor (locally called Lama) and trunk cleaner attached on side of mulcher,  
**b)** rotating star hoe (in german called Rollhacke) and trunk cleaner monuted on side of mulcher.

### *Efficiency of weed control*

Weeds always recovered quite fast after treatment. Due to the rainy summer and the very well supplied soil with nutrients, the weeds had a very lush development.

Among the one combination and one mechanical tool, the best result was achieved when using a combination of rotary hoe and vine trunk cleaner. The coverage with weeds ranged between 60 and 70%. When using a grass trimmer (Lama), the coverage with weeds ranged between 70% and 80%. Fuel and time consumption are very important in tillage in agriculture. Statistically significant differences between the two treatments were detected in the treatment time for the surface, tool 'Lama' was used at a speed of only 4 km/h, RH + FH at a speed of 5 km/h (Table 1). This proved the importance of higher soil processing speeds. On the other hand, tractor consumption (l/h) was similar in both treatments. When using the 'Lama' (4km/h) it took more than 10 minutes to cover 1 ha, compared to using the RH + FH (5 km/h) tool. In terms of environmental footprint, there are no big differences between the two treatments.

The 'Lama' tool has a similar energy consumption as the RH + FH combination, but the efficiency is not similar, it is better when combining the two tools. Processing speed (km/h) is very important in terms of time consumption, fuel consumption and processing efficiency. It will be necessary to use higher speeds in processing operations in vineyard. Achieved efficiencies was not optimal, because soil of the vineyard was always too wet and the tools did not work optimally. The speed was too low. For more precise weed control, the tools should be used 4 to 6 times at a higher working speed. The note is that the use of two tools (RH + FH) is more successful in controlling weeds compared to the 'Lama', which only cuts the weeds roots. When setting the tools, it has to be very precise, because too shallow or too deep processing does not lead to the desired effect. Since there was a lot of moisture in the soil, the weeds quickly recovered. With at least four treatments with mechanical tools per year, the use of herbicides in terms of effectiveness could be approach. The appropriate processing time has to be chosen, the right humidity and the size of the weeds. In the case of large weeds, which can be seen from the tractor cab, success is worse and as a result smaller yields could be expected.

**Table 1** Size of weed population expressed as the average rate of weed coverage (%) on a 0.5 m wide stripe under grapevine rows.

<b>Fuel consumption calculated without taking into account turning</b>	<b>Time consumption (sec) for the surface 230 m<sup>2</sup></b>	<b>Time consumption (min) for the surface 1 ha</b>	<b>Fuel consumption L h<sup>-1</sup></b>	<b>Fuel consumption L h<sup>-1</sup></b>
Driving down, operation RH + FH (5 km/h)	56a	39.13a	0.85a	0.59a
Driving up, operation RH + FH (5 km/h)	54a	40.21a	5.25b	4.04b
Driving down, Lama (4 km/h)	73b	52.17b	0.75a	0.55a
Driving up, Lama (4 km/h)	74b	52.9b	5.10b	3.92b

Values marked by the same letter, same colour and in the same column do not differ statistically significantly according to Tukey HSD test ( $p < 0.05$ ).

Berk et al. (2021) report that lost in vineyard of the crop yield per hectare could be huge, because of weeds, compared to weed free control. In experiment a good result with mechanical suppression tools was achieved. According to other experiments higher efficacy should be achieved (Manzone et al., 2020). In study of Manzone et al. (2020) the residual efficacy of mechanical control operations (cultivator and mulcher) was much longer, because of the better conditions in the summer season, with less rain on drier soil. The effect in our soil treatment was slightly worse also due to the shallower set tool, which will be changed in the next treatments.

### **Footprint**

For ecological footprint determination the SPI on Web program was used. The obtained results were analysed with the help of an online program for calculating the environmental footprint (SPI on Web). Calculations of the ecological impacts of technical processes on the environment throughout the entire life cycle were obtained. The ecological footprint of each production operation was estimated by including environmental impacts related to fossil-C ( $\text{kg CO}_2 \text{ hm}^{-2}$ ), air, water, soil, non-renewable, renewable, and area resources. (Kettel, 2022).

The ecological footprints of the vineyard operations are presented in Table 2. The largest footprint is related to a combination of rotating star hoe (RH) and a vine trunk cleaner (FH) ( $11247.1 \text{ m}^2 \text{ kg}^{-1}$ ). It is 14,2 % higher than ecological foodprint when using grass cutter (Lama).

**Table 2** Footprint and CO<sub>2</sub> emissions under different processing types

Processing type	Footprint/ $\text{m}^2 \cdot \text{kg}^{-1}$	CO <sub>2</sub> $\text{kg}^{-1}$
ROLL HOE + FINGER HOE	11247.1a	51.56a
GRASS CUTTER (LAMA)	9645.4a	45.40a

Values marked by the same letter do not differ statistically significantly according to Tukey HSD test ( $p < 0.05$ ).

The maximum amount of CO<sub>2</sub> is released while using combination of rotating star hoe and a vine trunk cleaner. At the grass cutter less CO<sub>2</sub> was released. In production in agriculture, a lot of carbon is released in the atmosphere. Bravo studied the Chilean sweet cherry production. The average carbon footprint of the Chilean sweet cherry production is 0.41 kg CO<sub>2</sub> eq/kg of harvested fruit. Diesel and fertilizers are the most important contributors to the carbon footprint of sweet cherry cultivation (Bravo, 2017). Environmental impact of food production is very important, and carbon footprint served as an indicator to guide farmland management. The conventional production system was found to have a Footprint value almost double than the organic production, mainly due to the agricultural phases. These suggest that reducing the ecological footprint of wine production could include organic procedures, a decrease in the consumption of fuels and chemicals, and an increase in the use of recycled materials in the packing phase (Galli et al., 2008).

## **CONCLUSIONS**

Mechanical weed control should be started early in the season when the weeds are still small, and control should be repeated 4 to 5 times, resulting in 3 times higher costs of weed control than by using herbicide glyphosate twice. The tested tools did not work properly when used in wet soils at speeds below 6 to 7  $\text{kmh}^{-1}$ . The grasses recover quickly. The combination of two tools RH + FH proved to be the right choice in terms of energy consumption and weed control. A higher processing speed (6-7  $\text{km/h}$ ), lower soil moisture and a suitable processing depth are very important to achieve the best results.



## ACKNOWLEDGEMENTS

The paper was prepared within the EIP project "TPGUNT" (Introduction of new mechanical and autonomous automated technologies for sustainable grape production in vineyards, Decision No: 33117-3002 / 2018/10), co-financed by the Ministry of Agriculture, Forestry and Food "Agency of the Republic of Slovenia" for agricultural markets and rural development, in connection with the Decree on the implementation of the cooperation measure from the Rural Development Program of the Republic of Slovenia for the period 2014-2020 and the Public Call for sub-measure 16.2 Support for pilot projects and development of new products, practices, processes and technologies.

## REFERENCES

- Antier, C., Kudsk, P., Reboud, X., Ulber, L., Baret, P. V., Messéan, A. (2020). Glyphosate use in the European agricultural sector and a framework for its further monitoring. *Sustainability*, 12(14), [5682]. <https://doi.org/10.3390/su12145682>
- Balsari, P., Marucco, P., Vidotto, F., Tesio, F. (2006). Assessment of different techniques for weed control in vineyard. In *Proceedings of Giornate Fitopatologiche*, 529-534.
- Berk, P., Paušič, A., Stajniko, D., Krajnc, A., Vindiš, P., Kelc, D., Belšak, A., Kosi, D., Lesnik, M. (2021). Efficiency of alternative weed control systems in the vineyard. 48. *Actual tasks on agricultural engineering*.
- Bravo G, Lopez D, Vasquez M, Iriarte A. 2017. Carbon Footprint Assessment of Sweet Cherry Production: Hotspots and Improvement Options. *Pol. J. Environ. Stud.* 26(2): 559–566.
- Galli, A., Kitzes, J., Pulselli, R., Borsa, S., Marchettini, N. 2008. Ecological Footprint Analysis Applied to the Production of Two Italian Wines. *Agriculture, Ecosystems & Environment*. 128(3):162-166. DOI:10.1016/j.agee.2008.05.015
- Kettl K H. SPI on Web. Available online: [https://spionweb.tugraz.at/%20SPionWeb\\_Stepbystep\\_eng](https://spionweb.tugraz.at/%20SPionWeb_Stepbystep_eng). Accessed on (2022-09-08)
- Manzone, M., Demeneghi, M., Marucco, P., Grella, M., Balsari, P. (2020). Technical solutions for under-row weed control in vineyards: Efficacy, costs and environmental aspects analysis. *Jour. of Agric. Eng.*, 51(1), 36-42. <https://doi.org/10.4081/jae.2020.991>
- Shrestha, A., Kurtural, S.K., Fidelibus, M.W., Dervishian, G., Konduru, S. (2013). Efficacy and Cost of Cultivators, Steam, or an Organic Herbicide for Weed Control in Organic Vineyards in the San Joaquin Valley of California. Article in *HortTechnology*. DOI: 10.21273/HORTTECH.23.1.99
- Tamagnone, M., Balsari, P., Manzone, M., Bozzer, C. (2011). Comparison of different spraying equipment used for weed control in vineyards and in orchards. In 11° Workshop SuProFruit 2011, 136-138

---

---



## AN APPROACH TO SAVE ON PLANT PROTECTION PRODUCTS IN CHERRY ORCHARDS

Erik RIHTER\*, Damijan KELC, Denis STAJNKO, Rajko BERNIK, Peter VINDIŠ, Vasilije FEMIĆ, Peter LEPEJ, Miran LAKOTA, Jurij RAKUN

\*E-mail of corresponding author: erik.rihter2@um.si

University in Maribor, Faculty of Agriculture and Life Sciences, Pivola 10, 2311 Hoče, Slovenia

### ABSTRACT

*The spraying of plant protection products (hereafter PPPs) in orchards is widespread as it is considered a powerful and effective approach to treat the plants in order to achieve high yields and better crop quality. However, despite some benefits that PPPs bring, such as increased economic potential in terms of increased food production, they can also have serious health consequences for people and possible negative effects on the environment. This paper describes an approach to reduce the use of PPPs but preserve the same effect, which is possible with precise localization of the spraying system and accurate estimation of the plat canopy properties. The presented system works on the principle of electromagnetic valve triggering control, which has been upgraded and tested in the framework of the TRANSFARM 4.0 project (Interreg CE). The paper includes an evaluation of the system in a cherry orchard. The obtained data was processed with the help of the IBM SPSS Statistics package, where descriptive statistics, frequency distribution, normal distribution analysis, and non-parametric statistical hypothesis test (The Wilcoxon signed-rank test) were calculated. The trial performed in cherry orchard show that the adaptive system brings a statistically significant saving of PPPs in range of 30%. It has been shown that the opening and closing of the valves is consistent with the coverage at the points where the leaf mass is present or absent. The system has proven to a very reliable and efficient way of precise application of PPPs and represents an important step towards more precision and reduced environmental impact.*

**Keywords:** *spraying system, sensors, efficiency, tree canopy, cherry, orchard*

## INTRODUCTION

It is well known that the use of PPPs is one of the most important elements for disease and pest control in the orchard and is indispensable for maintaining the health of the crop. World production of PPPs has increased at a rate of around 11% per year, from 0.2 million tonnes in the 1950s to over 5 million tonnes by 2000 (Carvalho, 2017). At the global level, total PPPs use in agriculture remained stable in 2020, at 2.7 million tonnes active ingredients (FAOSTAT, 2022). Sales of pesticides in the EU fluctuated  $\pm 6\%$  around the 350 000 tonnes per year mark during the period between 2011 and 2020 (Eurostat, 2022).

According to Bernardes et al. (2015) is only 1% of total PPPs effectively used to control insect pests on target plants. The large amounts of remaining pesticides penetrate or reach non-target plants and environmental media (Tudi et al., 2021). PPPs residues can have long-term negative effects on human and animal health and the stability of ecosystems (Kalyabina et al. 2021).

Policy makers and stakeholders are slowly becoming more and more aware that the excessive and unsystematic application of agrichemical inputs, is an obstacle to the development of sustainable agriculture. Several countries have enacted policies to regulate usage volume and agrichemical inputs in agricultural. For instance, in 2009, the European Parliament and the Council adopted European Directive 2009/128/EC on the sustainable use of pesticides and establishing a framework for Community action to achieve sustainable use of PPPs (European Union, 2009). The European Commission announced two PPP reduction targets as part of the Farm to Fork Strategy in May 2020 (European Commission, 2022). These are a 50% reduction in the use and risk of chemical pesticides and a 50% reduction in the use of more hazardous pesticides.

PPPs are a critical input in agricultural production. Continuous and undifferentiated pesticide applications are often made in orchards. Therefore, different methods of PPPs application in agriculture are increasingly important and involves several aspects. In addition to the properties of the active substances, the climatic conditions, the awareness of the operator, the target structure and the features of the equipment are very important (Manetto et al., 2021) effective and efficient application of PPPs. As the canopy is not uniform in structure and there are gaps between individual parts, targeted application of PPPs is important. The targeted variable-rate spray allows PPP usage to be precisely varied according to the target (orchard-tree) characteristics. Targeted application, i.e. when the target is present, can reduce pesticide loss and pollution. Variable rate application can only be achieved by real-time detection of the canopy, which can be achieved by sensor systems mounted on the sprayers (Yu et al., 2008; Gu et al., 2021). In recent years, LiDAR sensors have been used alongside ultrasonic sensors. LiDAR sensors are considered insensitive to environmental conditions, fast and accurate, which is a good compromise for agricultural purposes (Rosell and Sanz, 2012; Gu et al. 2021).

The aim of this research is to investigate, calculate and describe the potential amount of pesticide savings through an upgraded developed adaptive PPPs application sensors system that works on the principle of electromagnetic valve triggering control. The paper includes an assessment of how the system works in a cherry orchard. Preliminary tests have been carried out in an apple orchard and it is expect that the system would also be suitable for a cherry orchard. The initial estimate about the savings on PPP are that the system will save at least 20% on PPPs consumption, as compared to conventional pesticide application in the orchard.

## MATERIALS AND METHODS

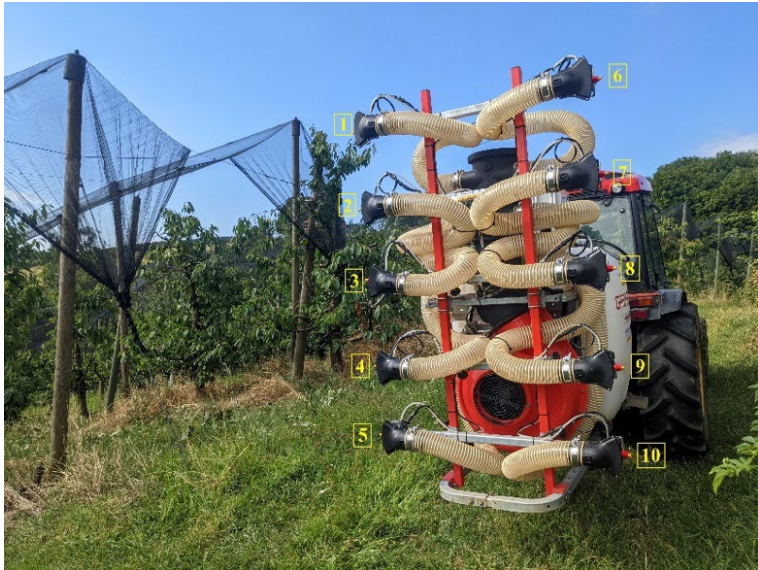
### *Upgraded developed sensor system*

The airblast sprayer used in the experiment is a Maschio Gaspardo S.p.A., model Turbo Teuton P Polipo with adjustable outlet pipes. The sprayer consists of a steel structure on which a 300 l polyethylene spray tank is mounted, a hydraulic pump, 10 (5+5) air hoses to supply the air flow and 10 (5+5) electro-magnetic valves which restrict the flow of spray slurry to the spray nozzles (Maschio Gaspardo, 2022).

The airblast sprayer is upgraded with a built-in spraying sensor system intended for reduced usage of plant protection agents that works by using readings from the two LiDAR (model TIM510) sensors (Figure 1). The first is vertically positioned – capturing the data needed to determine the presence of plant canopies, while the second is horizontally positioned LiDAR, which helps to determine the position of the system. Preliminary tests in apple orchard showed a maximum working height of 2.5 m to 3 m, while the working width was set between 2 m and 3 m. The mentioned a built-in spraying sensor takes advantage of the FieldSLAM algorithm, which was developed by Lepej and Rakun (2016). The mentioned system enables precise localization of the spraying system and accurate estimation of the plant canopy properties. Presented system works on the principle of electromagnetic valve actuation control. The valves on the airblast sprayer are identified by number, in order from top to bottom on the left-hand side, from number 1 to 5. The same applies to the valves on the right-hand side, marked 6 to 10, as depicted on Figure 2. The system used in cherry orchard was upgraded and improved as part of the Interreg Central Europe project Transfarm 4.0 in pilot action 2 – remote and proximal sensing (Transfarm 4.0, 2022).



**Figure 1** The airblast sprayer Turbo Teuton P Polipo with a built-in spraying sensor system



**Figure 2** Distribution of outlet pipes on the airblast sprayer and marked electromagnetic valves

### *Theoretical background for the built-in spraying sensor*

Behind the built-in spraying sensor hardware, as mentioned above, is the Field SLAM algorithm, based on concepts from computational geometry and computer vision, which estimates the position and orientation of the system based on calculation of the two consecutive readings from the horizontally placed LIDAR's data. Field SLAM (Lepej and Rakun, 2016) provides the built-in spraying sensor with a unique opportunity to place the airblast sprayer to in a natural environment, as it is specifically adapted to partially changing conditions, thus less error-prone where the readings correspond to partially moving trees (leaves and braches) or any other disturbances. An important challenge is the correct positioning of the sensors, as it is difficult to position the practical spray fittings (nozzles) and sensors side by side without the spraying affecting the data capture. Therefore, localisation is of utmost importance; it is necessary to know where the data on the presence of the plant canopy has been read and which tasks have been stored at the current location of the nozzles.

In order to make it easier to understand the concept of action, we briefly outline the basic principles below. The important part is the phase correlation (Gonzales and Woods, 2001), which compares the two images (one as reference, one as a template) composed by two successive readings of the LiDAR sensor presented in 2D space. When both images are registered, the correlation reaches a maximum value. If the correlation is computed in the frequency domain, the translation and rotation are separated and presented in the phase (translation) and amplitude (rotation) spectrum, without affecting one another, on the contrary to spatial space. So, the challenge of finding the right translation and rotation parameters can be solved separately.

The translation of the semi-identical signals in spatial space only affects the phase spectrum of the frequency transform. As the signals are semi-identical, their phase compensates but preserves their linear part. This produces a maximum global value with coordinates (cx, cy) that correspond to translation on the X and Y axes. If the log-polar transform is used before phase correlation, phase correlation can also be used to calculate rotation. The following equation calculates the correlation:

$$I_1(x, y) \circ I_2(x, y) = \frac{1}{MN} \sum_{m=0}^{M-1} \sum_{n=0}^{N-1} I_1^*(m, n) I_2(x + m, y + n) \quad (1)$$

where  $I_1(x, y)$  and  $I_2(x, y)$  represent a 2D signal (image) with  $M \times N$  pixels in size and  $I_1^*$  a complex conjugate of  $I_1$ .

By applying the convolution theorem, Eq. 1 can be written as:

$$I_1(x, y) \circ I_2(x, y) \Leftrightarrow S_1^*(u, v) S_2(u, v) \quad (2)$$

where  $S_1^*$  and  $S_2$  correspond to frequency transforms of the input signals  $I_1$  and  $I_2$ .

Based on the convolution theorem, the frequency domain's correlation can simply be calculated by multiplying the complex conjugate of the frequency transform of the first by the frequency transform of the second signal.

By transforming measurements and depicting them in spatial space, the consecutive reading shows up as translated outlines of the objects in the scene. Once these displacements are calculated according to last equation, they reveal the real displacements on both sides. The displacements are then simply used to compute new vectors with an origin starting at (0,0) located at the beginning of the row, approximately half the distance from each side of the row. Both vectors are then used in simple vector summation, which reveals the actual movement vector that is the difference along the X and Y axes and the new coordinates of the latest iteration.

### ***Implementation of the field experiment***

The experiment was carried out in a cherry orchard owned by the Faculty of Agriculture and Life Sciences (University of Maribor) in May 2022. Geographical orchard position 46° 30' 8.3016" N and 15° 37' 27.314" E. The cherry (*Prunus avium* L.) orchard has different varieties of cherry threes, namely: Celeste, Georgia, Sunbrust, Kordia and Regina. The test was conducted in a random row with a total length of 45 m. The experiment started with a control spraying of two rows, obtaining the standard theoretical PPPs consumption with the conventional use of the Maschio Gaspardo Turbo Teuton sprayer. The experiment was then repeated by using the built-in spraying sensor, where the computer module recorded a log file regarding open and closed statuses of each electro-magnetic valve individually. This data was later used to statistically evaluate the PPPs saving's percentage.

### ***Statistical design of the experiment***

The system in this paper is evaluated based on the recorded data sets from the previous subsection. The recorded data is processed using the IBM SPSS Statistics software package (version 26). The descriptive statistics is calculated, and the frequency distribution is checked. A non-parametric test, the Wilcoxon signed-rank test, is also performed as shown in the following section.

## RESULTS AND DISCUSSION

Descriptive statistics and frequency distribution is calculated by using recorded data sets. The data shows the frequency of opening of each individual valve on the airblast sprayer based on the readings from the presented system. This is useful for comparing the maximum possible number of openings that would be achievable without the presented system, compared to the number of instances where the system closes electro-magnetic valves due to missing (parts of) plants. This way the percentage of possible savings can be and is calculated. In addition, an analysis of the normality of the distribution is carried out. The analysis shows that the data is not normally distributed. Therefore, a non-parametric test is performed, or Wilcoxon signed - ranks test (Table 1), where each individual valve is compared with the valve at full (100%) opening, like it would be without the use of the sensor system.

The Table 1 shows the descriptive statistics and frequency distribution of the valves. The results show that valves 5 and 10 from the recorded data sets were open for the longest time. This can be explained by the structure of the cherry canopy. Valves 5 and 10 are located on average at a height of 65 cm, where the canopy of the trees starts, and the leaf mass is very dense. The lowest consumption or the frequency of valve opening would be at the top of the airblast sprayer, i.e. at valves 1 and 6, where the overgrowth of branches is lower or more unevenly distributed. The valve triggering results are also shown in Figure 3.

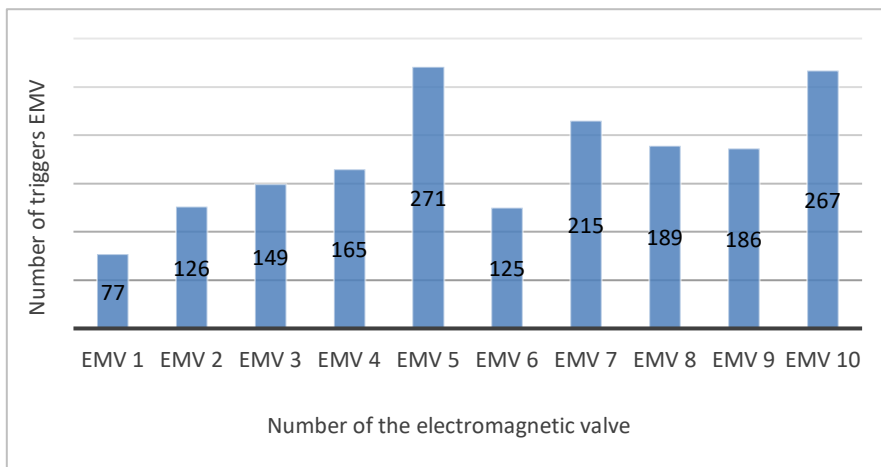
Table 2 shows the results of the Wilcoxon signed ranks test, showing that valve positions 5 and 10 have the lowest deviation and highest consumption, respectively, which is consistent with the results of the frequency analyses. Comparison of the consumption of each individual valve with the valve with the maximum open position shows that these differences are statistically significant, where it can be argued that the presented system in question provides more than 10% savings in PPPs consumption in the cherry orchard.

**Table 1** Descriptive statistics and frequency distribution of the electromagnetic valves

	<b>M</b>	<b>SD</b>	<b>Open</b>	<b>Close</b>
<b>EMV 1</b>	0.26	0.44	26.4%	73.6%
<b>EMV 2</b>	0.44	0.49	44.0%	56.0%
<b>EMV 3</b>	0.55	0.49	55.2%	44.8%
<b>EMV 4</b>	0.61	0.48	60.6%	39.4%
<b>EMV 5</b>	0.97	0.15	97.5%	2.5%
<b>EMV 6</b>	0.45	0.49	44.8%	55.2%
<b>EMV 7</b>	0.77	0.42	77.3%	22.7%
<b>EMV 8</b>	0.71	0.45	71.5%	28.5%
<b>EMV 9</b>	0.68	0.46	67.5%	32.5%
<b>EMV 10</b>	0.97	0.15	97.5%	2.5%

M - Mean, SD - Standard Deviation, Open - Proportion of time the valve was open, Closed - Proportion of time the valve was closed.





**Figure 3** Number of electromagnetic valve openings during the experiment

**Table 2** Wilcoxon signed ranks test results

	Z	p
EMV 1	-14.283	<0.001
EMV 2	-12.450	<0.001
EMV 3	11.136	<0.001
EMV 4	-10.440	<0.001
EMV 5	-2.646	0.008
EMV 6	-12.369	<0.001
EMV 7	-7.937	<0.001
EMV 8	-8.888	<0.001
EMV 9	-9.487	<0.001
EMV 10	-2.646	0.008

When using an airblast sprayer without a computerized valve control system with 100% valve opening in the control spray, the final consumption of PPPs was 16.77 l when spraying in a test row (45 m) of an orchard. Based on the recorded data, where the valves opened or closed according to coverage, with the final results show a 64.23% valve opening. This means that the for the same row of the cherry orchard, the consumption of PPPs is 10.77 l. From this it can be concluded that the saving of PPPs using the built-in spraying sensor system on the airblast sprayer is 35.77%.

A similar field trial with an identical system was carried out by Zanchini et al. (2022) in a vineyard in Italy, where savings of 60% were recorded. The authors also report a reduction in the large number of droplets lost as drift affects spray quality on the plant canopy. Berk et al. (2021) tested a modular electronic measuring and control system install on a conventional type of tractor-mounted sprayer in an apple orchard. Their system consists of three main components: a laser sensor, a microcontroller and a DGPS measurement system with RTK correction. The authors report a 69.8% saving of spray mixture through a single nozzle. The different sensors on the spraying systems therefore could be effectively employed for accurate canopy characterisation with their help, it is possible to achieve savings from 30 % of up to 80% in pesticides compared to conventional methods (Yu et al., 2008; Gu et al., 2021).

Assuming that the same PPPs application efficiency is maintained using a sprayer with the presented system and considering the calculated theoretical PPPs savings, it can be concluded that this is an effective approach to reduce PPPs use and concern for sustainable agriculture.

## CONCLUSIONS

The problem of uncontrolled and irresponsible PPPs use in agriculture has become a worldwide concern. Therefore, it is necessary to develop and test new methods for more effective PPPs application. Due to the variability in tree shape, the large spacing and turning points at the ends of rows, conventional continuous spraying, which is not always directed at the tree canopy, uses a lot of PPPs and therefore releases a lot of toxic chemicals into the environment. To solve this problem, the airblast sprayer has been designed and upgraded with a presented system for orchard and vineyard, which applies the exact amount of PPPs according to the green canopy of the tree and improves the efficiency of chemical use in orchards. The test was carried out in a cherry orchard to evaluate possible application approaches. The results show that a saving of 33.77% in PPPs application is achieved. Examination of the individual electromagnetic valves and the calculated statistics shows that the upgraded system helps to reduce PPP pollution by closing the electromagnetic valves according to canopy cover or where leaf mass is not present. The PPPs savings depend on the characteristics of the orchard or the crop. In addition, a built-in spraying sensor system helps to detect empty spaces in-between the trees which allows to control the spray and open the electro-magnetic valves if the plants are present and close them if the plants are not present in that area.

In conclusion, the designed and upgraded system represents an important step towards more precise PPPs application and more careful use of PPPs in cherry orchards and wider.

## ACKNOWLEDGEMENTS

This research was co-financed by the project by INTERREG CE program, Transform 4.0 project, under grant number CE1550.

The authors acknowledge the support of Mashio-Gaspardo that provided a state of the art airblast sprayer to conduct the trials.

## REFERENCES

- Berk, P., Lešnik, M., Paušič, A., Stajanko, D., Sečnik M. (2022). Efficiency of the autonomous modular system in the implementation of the spray application process in the vineyard. *Glasnik zaštite bilja: glasilo Sekcije za biljnu zaštitu Hrvatskog agronomskog društva*, 45 (5), 104–112.
- Bernardes, M.F.F., Pazin, M., Pereira, L.C., Dorta, D.J. (2015). Toxicology Studies—Cells, Drugs and Environment. IntechOpen; London, UK. *Impact of Pesticides on Environmental and Human Health*, 195–233.
- Carvalho, F.P. (2017). Pesticides, environment, and food safety. *Food Energy Secur*, 6, 48–60. European Commission.
- European Union. (2009). Directive 2009/128/EC of the European Parliament and of the Council of 21 October 2009 establishing a framework for Community action to achieve the sustainable use of pesticides. *Off. J. L 2009*, 309, 71–86.
- Eurostat. (2022). Agri-environmental indicator - consumption of pesticides. Retrieved on 1. October at [https://ec.europa.eu/eurostat/statistics-explained/index.php?title=Agri-environmental indicator - consumption of pesticides](https://ec.europa.eu/eurostat/statistics-explained/index.php?title=Agri-environmental_indicator_-_consumption_of_pesticides)
- FAOSTAT. (2022). Pesticides use, pesticides trade and pesticides indicators Global, regional and country trends, 1990–2020. Retrieved on 29. September at <https://www.fao.org/3/cc0918en/cc0918en.pdf>
- Gonzales, R.C., Woods, R.E. (2001). Digital Image Processing. 2<sup>nd</sup> Edition, Prentice Hall, New Jersey.
- Gu, C., Zhai, C., Wang, X., Wang, S. (2021). CMPC: An Innovative Lidar-Based Method to Estimate Tree Canopy Meshing-Profile Volumes for Orchard Target-Oriented Spray. *Sensors*, 21: 4252.
- Interreg Central Europe. (2022). Transfarm 4.0. Retrieved on 11. October at <https://www.interreg-central.eu/Content.Node/Transfarm4.0.html>
- Kalyabina, V. P., Esimbekova, E. N., Kopylova, K. V., Kratasyuk, V. A. (2021). Pesticides: Formulants, distribution pathways and effects on human health—a review. *Toxicology Reports*, 8, 1179–1192.
- Lepej, P., Lakota, M., Rakun, J. (2021). A sensory system for adaptive distribution of plant protection agents. Wageningen Academic Publishers, *Precision agriculture 2021: 740–758*.
- Lepej, P., Rakun, J. (2016). Simultaneous localisation and mapping in a complex field environment. *Biosystems Engineering*, 150, 160–169.
- Manetto, G., Cerruto, E., Longo, D., Papa, R. (2021). Special Issue on Pesticide Applications in Agricultural Systems. *Appl. Sci.* 2021, 11, 3695.
- Maschio Gaspardo (2022). Turbo Teuton P Polipo. Retrieved on 10. October at <https://www.maschio.com/en/web/international/turbo-teuton-p-polipo>
- Rosell, J.R., Sanz, R. A. (2012). Review of methods and application of the geometric characterization of tree crops in agricultural activities. *Comput. Electron. Agric.* 2012, 81, 124–141.
- Tudi, M., Daniel Ruan, H., Wang, L., Lyu, J., Sadler, R., Connell, D., Chu, C., Phung, D. T. (2021). Agriculture Development, Pesticide Application and Its Impact on the Environment. *International journal of environmental research and public health*, 18(3).
- Wandkar, S.V., Bhatt, Y.C., Jain, H.K. et al. (2018). Real-Time Variable Rate Spraying in Orchards and Vineyards: A Review. *J. Inst. Eng. India Ser. A* 99, 385–390.
- Yu, L., Huang, J., Zhao, Z.X., Zhang, L., Sun, D.Z. (2013). Laser measurement and experiment of hilly orchard tree canopy volume. *Trans. CSAM*, 44, 224–228.
- Zanchini, A., Masiero, L., Rihter, E., Lepej, P., Rakun, J. (2022). Potential pesticides losses reduction thanks to lidar sensors and nozzles section control. IX National Congress of viticulture, 13-15 June 2022 – Conegliano (TV).

---

---



## THE EFFECT OF DIFFERENT LED LIGHTING ON THE GROWTH OF *ERUCA SATIVA* (MILL.)

Denis STAJNKO\*, Peter BERK, Damijan KELC, Miran LAKOTA, Jurij RAKUN

\*E-mail of corresponding author: denis.stajnko@um.si

University of Maribor, Faculty of Agriculture and Life Sciences, Chair for Biosystems Engineering,  
Pivola 10, 2311 Hoče, Slovenia

### ABSTRACT

*The growth of rocket Eruca sativa (Mill.) was studied during 30 days of growing in the chamber under different lighting regimes; T5\_peak at 630 nm, LED1\_peak at 545 nm and LED2\_peak at 599 nm. There were no significant differences in dry weight after 15 days, however, from day 15 to 30, the increase in dry weight was for 111% and 227% higher under the LED2 than under LED1 and T5, respectively. The regression analysis revealed the strongest correlation between the dry weight and PPFD\_B light intensity (0.661\*\*), showing the positive effect of additional LED lighting.*

**Keywords:** Fresh weight, Dry weight, Leaf area, LED, rocket

### INTRODUCTION

Vegetables from the *Brassicaceae* family are widely cultivated and valued as a healthy food source. So, they have frequently been widely studied as a potential source of health-promoting compounds, and epidemiological studies indicate that their consumption may reduce the risk of several types of cancer (Higdon et al., 2007).

*Eruca sativa* (Mill.) known as rocket (arugula, rucola, roquette), is a vegetable considered to be increasingly important in the salad vegetable market in the areas surrounding the Mediterranean Sea (Pasini et al., 2012). Rocket contains many health-promoting compounds, including vitamins, carotenoids, polyphenols and diverse group of glucosinolates. (Tan et al, 2020).

During the various growth stages of plants, light is the primary source of energy for photosynthesis and one of the most critical environmental factors required for growth (Muneer et al., 2014). It has been established that plants respond to photosynthetically active radiation (PAR) with a waveband of 400–700 nm, and the role of light is vital for photosynthetic biosynthesis and productivity (Ghasemzadeh et al., 2010). Low light results in etiolated plants,

while excessive light generates oxygen radicals, triggering photoinhibition, both of which strongly limit primary productivity (Darko et al., 2014).

Among the PAR, blue (400–500 nm) and red (600–700 nm) light wavelengths have the greatest impact on plant growth and development, because they are absorbed by chlorophyll pigments or other secondary pigments reinolved in carbon fixation and basic metabolism (Metallo et al., 2018).

For instance, Kopsell et al. (2015) reported that different RB LED light treatments of 5% blue (470 nm)/95% red (630 nm), 5% blue/85% red/10% green (530 nm), and 20% blue/80% red at an intensity of  $250 \pm 10 \mu\text{mol m}^{-2} \text{s}^{-1}$  cause significantly higher individual and total aliphatic and total indole glucosinolates in broccoli (*Brassica oleracea* var. *italica*) grown under a fluorescent light treatment.

Tan et al. (2020) showed that the growth of pak choi (*Brassica rapa* subsp. *chinensis* var. *parachinensis*) under  $160 \mu\text{mol m}^{-2} \text{s}^{-1}$  red-blue (160RB) LED light produced the highest shoot fresh weight and dry weight for all three growth stages tested (i.e., one-leafed seedlings, three-leafed seedlings and adult plants).

The main purpose of this study was to investigate the yield potential of *Eruca sativa* (Mill.) at different growth stages under different LED light types.

## MATERIAL AND METHODS

### *Plant materials and growing conditions*

Seeds of rocket were sown in germination trays (54 cm×27 cm×6 cm) filled with BIO Potgrond mix (Klasmann-Deilmann GmbH, Geeste, Germany). Approximately 1.4 g of seeds were sown in each germination tray before 3 L of tap water was added. Subsequently, each tray was watered every two days with 1 L of tap water by sub-irrigation. All plants were grown indoors at  $25 \pm 2^\circ\text{C}/22 \pm 2^\circ\text{C}$  (light/dark) and  $65 \pm 5\%$  relative humidity under three different light regimes; T5 (LUMii, 60 cm, 87 W supplied by EnviroGro), LED 1 (TXVSO 600W LED Grow Light, unknown supplier) and LED 2 (SAMSUNG LM301B, 80W supplied by EasyGrow S600). Each light was applied in three repetitions for 15 and 30 days.

### *Biomass and growth parameter analyses*

For growth evaluation the total fresh (FW) and dry weight (DW) of individual plants were measured 15 and 30 days after sowing. Twenty-five plants (n=25) per treatment were randomly selected at both intervals and destructively sampled for biomass analysis. The FW and DW of individual plants were recorded using a three-decimal-point electronic balance (Mettler Toledo ML303 Precision Balance; Greifensee, Switzerland). Biomass partitioning was determined by measuring the FW and DW of the various plant parts (e.g., leaves, petiole, stem and roots). Samples were dried in the oven at  $60^\circ\text{C}$  till the weight stabilised.

Total leaf area (LA) of each plant was determined by photographing laminas for each plant using a camera (Canon EOS 2000D; Tokyo, Japan), followed by leaf area determination using Image J v. 1.51 (National Institute of Health; Bethesda, MD, USA).

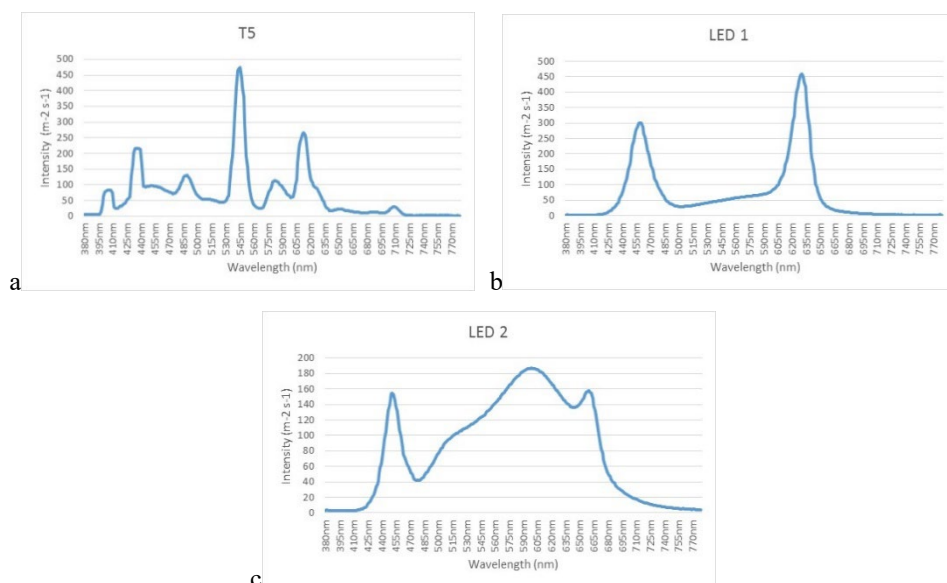
### *Light characterisation*

The spectral characteristics expressed as PPFD-UV, PPFD-B, PFD-G, PPFD-R and PPFD-FR magnitude per ( $\mu\text{mol m}^{-2} \text{s}^{-1}$ ) were determined using a light spectrometer (Uprtek

AI-MK350D). The spectral output of all lights is shown in Fig. 1, where it can be seen that most energy packets arrive in different wavelength bands with peaks at 545 nm (T5), 599 nm (LED 2) and 630 nm (LED 1). Secondly, a broad wavelength photosynthetically active radiation (PAR) expressed as PPFD\_B, PPFD\_G and PPFD\_R (Table 1), showed differences in distribution between the lights in the area 0.2 m directly below and adjacent to the light source. The T5 has the biggest PAR output in PPFD\_G band (51.847  $\mu\text{mol m}^{-2} \text{s}^{-1}$ ), while LED1 has it in the PPFD\_R band (66.126  $\mu\text{mol m}^{-2} \text{s}^{-1}$ ). In contrast, LED2 shows practically the same PPFD\_R, as well as the PPFD\_G band (65.669  $\mu\text{mol m}^{-2} \text{s}^{-1}$  and 63.305  $\mu\text{mol m}^{-2} \text{s}^{-1}$ ).

**Table 1** The difference in PAR spectrum between different lights ( $\mu\text{mol m}^{-2} \text{s}^{-1}$ )

PAR	T5 (80 W)	LED1 (80 W)	LED2 (80 W)
PPFD-UV	0.863	0.133	0.195
PPFD-B	36.015	35.380	21.077
PPFD-G	51.847	24.358	63.305
PPFD-R	30.534	66.126	65.669
PPFD-FR	3.100	1.399	4.631



**Figure 1** Spectral output of T5 (a), LED 1 (b) and LED 2 (c) lights installed in the grow-cell.

### *Statistical analyses*

All statistical analyses were performed using IBM SPSS Statistics 25 (IBM, 2020), using two-way analysis of variance (ANOVA) for the interaction effects of factors on the dependent parameter. When an interaction effect was not confirmed, one-way ANOVA was used for interpreting the effects of each tested factor. The differences in the content levels were estimated by Duncan's test. P-values of less than 0.05 were considered statistically significant.

## RESULTS AND DISCUSSION

### *Growth assessment of rocket in response to different light*

Unfortunately, the weight of leaves and stems after 15 days of growth was too low for separate estimation (Fig. 2), so only the data for the whole plants are presented. As shown in Table 2, there was no difference in dry weight after 15 days, probably due to the very short initial sampling period. After 30 days of growing the highest total dry weight (1.235 g) was measured under LED2, while there was no difference between T5 and LED1 lights.



**Figure 2** Rocket plants after 15 days (upper line) and 30 days of growing under - a (T5), b (LED1) and c (LED2) light



When comparing the plant parts that are of commercial interest (leaves and stems), the highest fresh yield of leaves (10.155 g) was measured under LED2 light, as well (Table 3).

**Table 2** Effects of different LED light types on shoot dry weight (DW)

Treatment	Total DW 15 days, (g)	Total DW 30 days, (g)	Root DW 30 days, (g)	Leaf DW 30 days, (g)	Stem DW 30 days, (g)
T5	0.068 a	0.581 b	0.023 b	0.541 b	0.020 a
LED1	0.066 a	0.652 b	0.022 b	0.620 b	0.015 a
LED2	0.070 a	1.235 a	0.060 a	1.280 a	0.023 a

<sup>a,b,c</sup> significant at  $p < 0,05$  (Duncan)

**Table 3** Effects of different LED light types on shoot fresh weight (FW)

Treatment	Total FW 15 days, (g)	Root FW 30 days, (g)	Leaf FW 30 days, (g)	Stem FW 30 days, (g)	Total FW 30 days, (g)
T5	0.817 a	0.254 bc	6.486 b	0.228 a	6.968 b
LED1	0.773 a	0.259 b	7.270 b	0.166 a	7.695 b
LED2	0.560 b	0.478 a	10.155 a	0.176 a	10.809 a

<sup>a,b,c</sup> significant at  $p < 0,05$  (Duncan)

The regression analysis between different light intensities and plants parts (Table 4) revealed that the increase in total dry matter is correlated with the PPFD\_B light intensity ( $r=0.661^{***}$ ). The same was estimated for the leaves and roots, while there was no correlation for the stem. Contrary, there was very weak correlation with PPFD\_R and PPFD\_G intensity and leaves, stems and roots, respectively.

**Table 4** Correlation coefficients between different PPFD light intensity and DW after 30 days

	Leaves	Stem	Roots	Total
PPFD_R <i>Eruca sativa</i>	0.394*	0.038 n.s.	0.350*	0.380*
PPFD_G <i>Eruca sativa</i>	0.451*	0.245 n.s.	0.552*	0.434*
PPFD_B <i>Eruca sativa</i>	0.686***	0.188 n.s.	0.742***	0.661***

\*significant at  $p < 0,05$ , \*\*\*significant at  $p < 0,01$ , \*\*\*\*significant at  $p < 0,001$

### ***Leaf area assessment of rocket in response to different light***

Table 5 shows the effects of the different LED light types on LA development, since the leaves represents most important market value of the rocket plant. As can be seen, the highest leaf area per plant was measured under LED1 light for both samplings i.e. 18.489 cm<sup>2</sup> after

15 days and 248.88 cm<sup>2</sup> after 30 days. The same was measured for the increase in LA (230.391 cm<sup>2</sup>).

The regression analysis showed the strongest positive correlation between the PPFD\_R light intensity after 30 days of growing ( $r=0.840^{***}$ ) and the PPFD\_R light intensity and the increase of LA ( $r=0.817^{***}$ ), respectively (Table 6). In contrary, there was very weak correlation between the PPFD\_G and PPFD\_B light intensity and LA. These findings correspond only partly with those of Tan et al. (2020), who reported a significant effect of RB LED light on shoot growth in choy sum; on the other hand, Kopsell et al. (2015) found no positive effect for blue light on mustard (*Brassica juncea* L.) microgreens.

**Table 5** Effects of different LED light types on LA development

Treatment	LAI 15 days (cm <sup>2</sup> / plant)	LAI 30 days (cm <sup>2</sup> / plant)	Increase (cm <sup>2</sup> / plant)
T5 <i>Eruca sativa</i>	8.170 b	35.490 b	27.320 b
LED1 <i>Eruca sativa</i>	14.325 a	154.580 a	140.255 a
LED2 <i>Eruca sativa</i>	5.401 bc	19.270 b	13.870 b

<sup>a,b,c</sup> significant at  $p<0.05$  (Duncan)

**Table 6** Correlation coefficients between different PPFD light intensity and LA

Treatment	LAI 15 days	LAI 30 days	LAI Increase
PPFD_R <i>Eruca sativa</i>	0.589**	0.840***	0.817***
PPFD_G <i>Eruca sativa</i>	0.310	0.217	0.268
PPFD_B <i>Eruca sativa</i>	0.706***	0.427*	0.366*

\*significant at  $p<0.05$ , \*\*significant at  $p<0.01$ , \*\*\*significant at  $p<0.001$

## CONCLUSIONS

This study has highlighted differences in growing potential of rocket under controlled indoor conditions with three different LED light types. This is in contrast with field conditions, which often stress plants and create phytochemical profiles reflective of fluctuating environmental stresses such as light intensity, temperature, pests and disease.

The use of LED lighting with higher PPFD\_R and PPFD\_B intensity is favorable to high yield in commercial categories of rocket (leaves), however, but these effects were not linear. FW and DW production were more influenced by PPFD\_B than by PPFD\_G. On the other hand, leaf area development was mostly affected by PPFD\_R, so it can be assumed that it was the cumulative effect of genotype and lighting, which means that improving the productivity of indoor growing systems is not possible without including PPFD\_G and PPFD\_FR as well.

To overcome the lack of understanding of the interaction among different wavelengths and glucosinolates content of the rocket, future research should investigate monochromatic

LED light, which could be used to optimize photosynthesis effectiveness more precisely. With such approach one could investigate the expression of genes necessary for the biosynthesis of both phytohormones and glucosinolates more precisely.

### ACKNOWLEDGEMENTS

The results presented are an integral part of the project CRP V4-1815 titled "Reducing of draught stress and increasing of soil fertility by introducing conservation (conservation) soil tillage into sustainable agriculture", which is financed by the Slovenian Research Agency and the Ministry of Agriculture, Forestry and Food of the Republic of Slovenia. The authors would like to thank Marko Gomboc, B.Sc. for maintaining the experiment.

### REFERENCES

- Darko, E., Heydarizadeh, P., Schoefs, B., Sabzaljan, M. R. (2014). Photosynthesis under artificial light: the shift in primary and secondary metabolism. *Philos. Trans. R. Soc. B* 369, 20130243.
- Ghasemzadeh, A., Jaafar, H. Z., Rahmat, A., Wahab, P. E. M., Halim, M. R. A. (2010). Effect of different light intensities on total phenolics and flavonoids synthesis and anti-oxidant activities in young ginger varieties (*Zingiber officinale* Roscoe). *Int. J. Mol. Sci.* 11, 3885–3897.
- Higdon, J. V.; Delage, B.; Williams, D. E.; Dashwood, R. H. (2007). Cruciferous vegetables and human cancer risk: epidemiologic evidence and mechanistic basis. *Pharmacol. Res.* 55 (3), 224–236. (4).
- Kopsell, D. A., Sams, C. E., Morrow, R. C. (2015). Blue Wavelengths from LED Lighting Increase Nutritionally Important Metabolites in Specialty Crops. *Hortscience* 50(9), 1285-1288.
- Metallo, R. M., Kopsell, D. A., Sams, C. E., Bumgarner, N. R. (2018). Influence of blue/red vs. white LED light treatments on biomass, shoot morphology, and quality parameters of hydroponically grown kale. *Sci. Hortic.* 235, 189–197.
- Muneer, S., Kim, E. J., Park, J. S., Lee, J. H. (2014). Influence of green, red and blue light emitting diodes on multiprotein complex proteins and photosynthetic activity under different light intensities in lettuce leaves (*Lactuca sativa* L.). *Int. J. Mol. Sci.* 15, 4657–4670.
- Pasini, F., Verardo, V., Caboni, M. F., & D'Antuono, L. F. (2012). Determination of glucosinolates and phenolic compounds in rocket salad by HPLC-DAD-MS: Evaluation of *Eruca sativa* Mill. and *Diplotaxis tenuifolia* L. genetic resources. *Food Chemistry* 133(3), 1025–1033.
- Tan, W. K., Goenadie, V., Lee, H. W., Liang, X., Loh, C. S., Ong, C. N., Wah Tan, H. T. (2020). Growth and glucosinolate profiles of a common Asian green leafy vegetable, *Brassica rapa* subsp. *chinensis* var. *parachinensis* (choy sum), under LED Lighting. *Scientia Horticulturae* 261, 108922.

---

---



## RESEARCH ON THE ULTRASONIC EXTRACTION OF VOLATILE SEA BUCKTHORN OILS

Emilia DOBRIN\*, Nicușor-Alin SÎRBU, Gabriela-Victoria MNERIE

\*E-mail of corresponding author: edobrin@isim.ro

National R&D Institute for Welding and Material Testing - ISIM Timisoara, 30, Mihai Viteazul Biv.  
300222 Timișoara, România

### ABSTRACT

*Sea buckthorn is a much-researched plant, due to the multiple possibilities of exploitation, so beneficial for human health, there is a great interest in the extraction of oil from sea buckthorn, the necessary special technological conditions are hardly respected. In this sense, multidisciplinary approaches are needed. This work supports the use of ultrasound as a modern and advantageous technical solution. The results of a research regarding the choice of the optimal constructive variant of the technical system, especially of the active element, the sonotrode, are presented, a selection criterion being the generated temperature. The elements of the processing regime are determined to ensure a greater efficiency of the extraction operation and a better quality of the volatile oils obtained from sea buckthorn. The obtained results can lead to an improvement of advanced processing technologies of plant resources from fruit and viticulture, to obtain nutraceutical products with high added value.*

**Keywords:** *Sea buckthorn, volatile oils, ultrasonic extraction, technic system, sonotrode.*

### INTRODUCTION

The superior utilization of plant resources resulting from fruit growing and viticulture, represents a major objective for the broad, multidisciplinary research, contained under the big dome of "life sciences". For its special value, it is frequently researched Sea buckthorn, belongs to the family Hippophae rhamnoides which is a dioecious species. It produces male and female flowers on separate legs, and which are pollinated by wind (Rousi, 1971).

The sea buckthorn plant is known as "Romanian ginseng", (assessment made by Prof. Ion Brad). It has waxy grains and contains a single integrated seed, as well as a cellular structure that contains the juicy pulp and core. The pulp and fruits are a good source of carotenoids, as can be seen by their rich colors.



**Figure 1** *Sea buckthorn* fruits

The most valuable nutrients of sea buckthorn berries are their oils. Sea buckthorn oil is generally obtained from the pulp and the shell, which are difficult to separate. From the whole sea buckthorn shrub - Sea buckthorn fruits have the highest antioxidant activity: 93.6% among medicinal plants, being a rich source of bioactive substances (Asofiei and Callinescu, 2019) and (Kyriakopoulou and Pappa, 2013).

The nutritional composition of sea buckthorn has over 200 phytonutrients and functional components, the most representative of which are: natural antioxidants - phenolic compounds, nitrogen compounds, amines or carotenoids, phytosterols, phospholipids, 22 fatty acids - omega-3, omega-6, omega-7, omega-9 (buckthorn being probably the only plant in the world that provides all Omega acids), 14 vitamins (A, D, E), K, group B and P), 11 minerals (Zn, Fe, Mn, Ca), 42 lipids (5, 6). (Bal and Meda, 2011). Oil can be extracted from the pulp as well as from the sea buckthorn seeds. They differ from each other in consistency, color, and nutritional profile.

Compared to seed oil, sea buckthorn pulp oil has a darker shade (orange to red), a viscous consistency, with a high content of omega 7 and carotenoids. Despite these differences, both types of sea buckthorn oil are associated with several important health benefits and are in high demand in the market by consumers and beauty benefits (Isopencu and Stroescu, 2018).

Due to the significant amount of beta-carotene and vitamin E, the oil has strong antioxidant, anti-aging, anti-aging effects, which have beneficial anti-cancer, anti-ulcer, growth-stimulating effects for skin diseases (Mingyue and Gong, 2020).

Several methods are known for extracting active compounds from sea buckthorn fruits. Both classical and innovative extraction methods were studied.

In general, conventional extraction processes consist of two main steps: mixing with some type of solvent, followed by hydration; through the action of diffusion and mass permeation, soluble compounds pass into the extraction solvent. These techniques rely on the extraction power of different solvents and the application of heat and/or mixing to increase the rate of mass transfer by increasing the solubility of the compounds. (Tlais and Fiorino, 2020).

Among the classic extraction methods, we mention maceration, mechanical cold pressing, respectively those based on air drying or freeze drying (lyophilization) of sea buckthorn seeds and pulp. The most common method of obtaining plant extracts is solvent extraction. The extraction process is influenced by the type of solvent, solvent/plant ratio, temperature, extraction time or stirring rate (Bansal and Singh, 2018) and (Bal and Meda, 2011).

Among the disadvantages of the classic variants (Bal and Meda, 2011; Alexandre and Moreira, 2018; Asofiei and Călinescu, 2019):

- the need to use large quantities of dangerous organic solvents, which are polluting for the environment and represent a health hazard;
- long extraction time;
- interference and degradation of the targeted components due to internal and external factors, such as light, air, high temperatures and enzymatic reactions;
- low efficiency due to long extraction times, high temperatures and degradation of bioactive compounds (polyphenols), (Alexandre and Moreira, 2018) and (Asofiei and Călinescu, 2019).

Among the innovative technologies possible to apply to sea buckthorn fruits (Rousi, 1971), were analyzed: accelerated solvent extraction; subcritical water extraction; supercritical fluid extraction; microwave extraction; high pressure extraction; extraction with pulsating electric fields; high voltage electric discharge extraction; ultrasonic extraction (Khoddami and Wilke, 2013) and (Shams and Abdel-Azim, 2015). Compared to the classical methods, the innovative/unconventional ones shorten the extraction times, reduce the release of toxic pollutants by reducing the consumption of organic solvents and are relatively simple to perform. A big disadvantage is the high cost of the necessary equipment. However, in the case of antioxidant extraction, where products are in high demand and high extract purity and processing efficiency are expected, equipment price may not play a critical role in the selection of these methods (Khoddami and Wilke, 2013).

Of course, the ideal method should be quantitative, non-destructive, and timesaving. In the category of modern techniques, with very good references related to the possibility of application in the case of sea buckthorn fruits, ultrasonic extraction was chosen for this research.

## METHODS

Sonification is an emerging and promising 'green', non-destructive, multi-purpose technology used in the food industry in recent years. Sonification has a diverse application in food science and technology, which is used in the study of food composition (fruit, vegetables and dairy products) and in the detection of foreign material contamination in canned and dairy products, freezing, decolorization, degassing, extraction, drying, filtration, emulsification, sterilization, cutting etc., (Majid and Gulzar, 2015), (Kehinde and Sharma, 2020), (Hypericumimpex, 2022).

Ultrasound finds its applicability in the food, pharmaceutical and cosmetic fields (Coman and Teleky, 2019), (Alexandre and Moreira, 2018), (Putnik and Lorenzo, 2018). This form of ultrasound-generated energy can be applied to improve the quality characteristics of high-quality foods, as well as to ensure the food safety of a wide range of foods, while minimizing negative effects on the sensory characteristics of foods, while providing more opportunities in food compositional analysis. (Arvanitoyannis and Kotsanopoulos, 2015), (Knorr and Froehling, 2011).

The ultrasonic extraction method uses different physical and chemical phenomena than conventional methods. The main effect of ultrasound on a liquid is the phenomenon of cavitation. This method involves the use of ultrasound, with frequencies between 20 kHz and 2000 kHz, which increase the permeability of cell walls and produce cell lysis, thus favouring the extraction of bioactive compounds. Ultrasonic extraction allows the solvent to penetrate the cell walls and the bubbles produced by the acoustic cavity favour cell wall breakage and

release of bioactive compounds, thus increasing the extraction yield. In general, in an ultrasonic resonator assembly, there are three main components: the electric generator, the converter, the amplifier, the sonotrode (Amza, 2016). In general, the minimum necessary equipment consists of: - Ultrasound generator 500 W – 40 kHz; - piezoceramic transducer; - Booster (Amplifier); - Sonotrode specially designed for sonochemistry.

The electric generator converts the alternating current, 50 Hz taken from the mains, into high frequency alternating currents. The converter converts electricity into mechanical vibrations at ultrasonic frequencies. The piezoelectric transducer converts electrical current into physical vibrations.

The role of the amplifier is to adjust the frequency as needed. The sonotrode concentrates and guides the mechanical vibrations in the active area.

Carefully studying the specialized literature and based on the experience accumulated in previous research, especially in the application of ultrasound for the extraction of resveratrol from vegetable waste from viticulture previously (Dobrin and Iacobici, 2021), it was found that the important factors on which the performance of the method application depends, are: the construction of the sonotrode active element, as well as the applied parameters, such as power, frequency, extraction time, temperature created in the extraction environment.

As the main objective of the research, the optimal constructive choice of the sonotrode was established, with the determination of an appropriate working regime, so as to result in a temperature as low as possible during the ultrasonic processing, knowing that at a temperature higher than 45 °C there would be the risk of destruction the quality of vegetable oils found in sea buckthorn (BIOHORTINOV, 2022).

The experimental program was carried out in the specialized laboratories of National R&D Institute for Welding and Material Testing - ISIM Timisoara.

#### ***Preparation of the liquid composition subject to extraction***

In the first stage of the experimental program, 10 batches of sea buckthorn berries were prepared to be subjected to extraction. For each batch, 20 g of chopped sea buckthorn (pulp and seeds) were weighed and placed in a graduated container together with 80 mL of absolute ethyl alcohol (99.5% concentration) and 120 mL of distilled water. The samples were hermetically sealed and left to macerate for 96 hours at an ambient temperature of 20 °C.



**Figure 2** Samples prepared for extraction



After the maceration of the samples was finished, it was moved to the second phase of the experimental program, the ultrasonic processing.

### ***Technical system design***

Analyzing the type and consistency of the liquid subjected to ultrasonic action, considering the degree of processability, the Titanium Grade 5 alloy (Ti Gr 5 / 3.7165), which is the most used titanium alloy, was chosen as the material from which to make the sonotrode. characterized by good machinability, good chemical resistance to a variety of corrosive environments, below 300 °C, recommended for components of medical and food equipment. (Hempel, 2022).

From the results of previous experimental research, (Dobrin and Iacobici, 2021), for the ultrasound extraction of sea buckthorn oils, it was necessary to choose the best option between 2 experimental models of technical systems, made to work at the frequency of 20 kHz, respectively at 43 kHz.

To establish the geometry of the sonotrode, a proprietary ISIM software was used, specialized for the behavioral simulation of the 2 sonotrodes. After running the simulation program, the shape, and external dimensions of the sonotrode being determined, its design was executed using the Solidworks program. The characteristics of the 2 sonotrodes were thus determined and presented in table 1.

**Table 1** Characteristics of sonotrodes determined

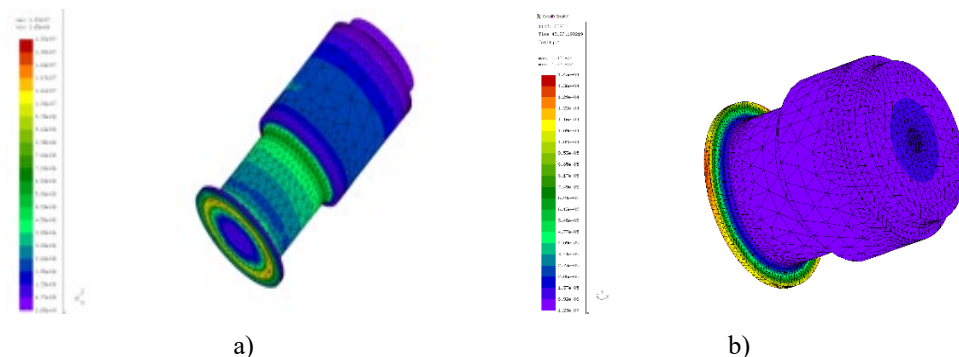
<b>Characteristics determined</b>	<b>Sonotrode 1</b> (Frequency 20 kHz)	<b>Sonotrode 2</b> (Frequency 43 kHz)
Input Amplitude	1 $\mu\text{m}$	1 $\mu\text{m}$
Amplification ratio (k)	2.28	1.94
Maximum axial stress variation	1.92 MPa Quota X = 79.5 mm	3.87 MPa Quota X = 41.0 mm
The maximum cumulative strain energy	$1.98 \cdot 10^{-4}$ J	$4.52 \cdot 10^{-4}$ J
Maximum cumulative energy losses	$9.5 \cdot 10^{-4}$ W	$4.4 \cdot 10^{-3}$ W
Oscillation amplitude variation, with nodal point in X	Coord. X = 30.3 mm	Coord. X = 24.6 mm

Based on the mechanical and acoustic characteristics of the material, the variation of the speed of sound propagation in the material was determined as a function of temperature.

Then the axial stress variation, the cumulative deformation energy and respectively the cumulative energy losses, (in volume and linear) were studied, the axial stress variation (highlighting the maximum value resulting from the simulation), the variation of the oscillation amplitude along the sonotrode highlights a point zero oscillation nodal.

In figure 3 the Von Misses equivalent stresses are highlighted, which are concentrated and reach maximum values even higher than the mechanical resistance of the material, namely 345 MPa, in the area of the outer diameter of the active surface of the sonotrode, which is

represented with a reddish-yellow color, but without risks, being far outside the practice regime of ultrasound, ( $< 100$  MPa).



**Figure 3** Representation of the Von Mises equivalent stress, using CalculiX:  
**a)** sonotrode 1, (20 kHz); **b)** sonotrode 2, (43 kHz)

During the design stage, other geometries of sonotrodes that could be used in the ultrasonic extraction of oils were considered. The sonotrodes designed by ISIM Timisoara experts were simulated with the help of the Krell Engineering specialized program, to determine their geometric and dimensional characteristics, after which they were modeled using the 3D SolidWorks program; the resulting data being entered into the SonoAnalyzer Pro program to simulate the axial stresses that may appear along the sonotrodes during their use, simultaneously highlighting the areas prone to cracking (active surfaces subject to contractions and expansions of the order of  $20000\div 40000$  oscillations per second) as well as the deformation their elasticity during ultrasonic activation.

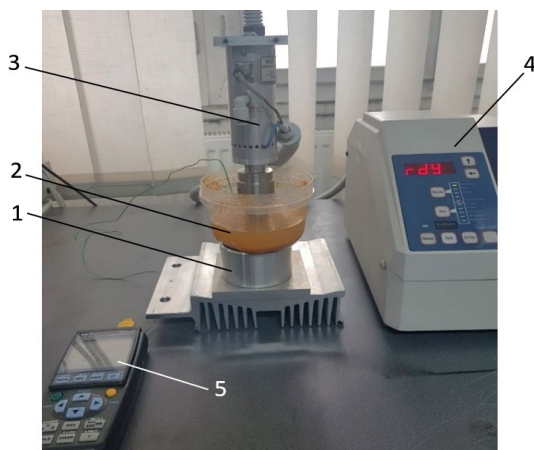
Based on the obtained design data, the 2 sonotrodes were executed.

### ***Running the ultrasound process***

After macerating the sea buckthorn samples (2), they were subjected to the ultrasound treatment process using the ultrasonic assembly (3) and generator (4), in 5 batches for each sonotrode. The duration of each experiment was 10 minutes. The temperature was continuously monitored, using the thermometer YC-724 (5). The amplitude was measured before the start of the experiment using a vibrometer.

The working parameters and the sequential values of the temperature in the liquid sea buckthorn mixture, were centralized in table 2. The monitoring of the temperature variation during the ultrasounds was also carried out of the desire to notice any exceeding of the allowed limit temperature of  $45$  °C.

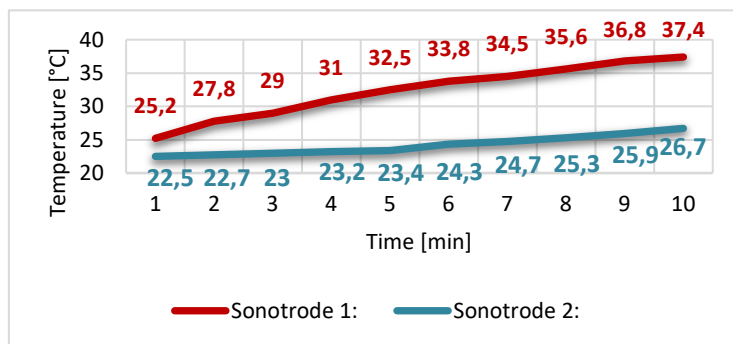
The temperature evolution in relation to the ultrasonication time is represented in the graph in figure 5. The ultrasonically processed samples were sealed and forwarded to the specialized laboratory for the final extraction of sea buckthorn oil.



**Figure 4** Ultrasound experimental stand of the macerated sea buckthorn liquid mixture, made up of: 1 - sample holder; 2 - sample of sea buckthorn; 3 - ultrasonic assembly; 4 - ultrasonic generator; 5 - thermometer YC-724

**Table 2** Evolution of temperature in relation to time, results during the extraction

Extraction time [min]	Average temperature recorded at the end of the extraction period, [°C]										
	1	2	3	4	5	6	7	8	9	10	
<b>Sonotrode 1:</b>											
Power = 3000 W											
Frequency = 20 kHz	25.2	27.8	29.0	31.0	32.5	33.8	34.5	35.6	36.8	37.4	
Starting temperature = 23 °C											
Amplitude = 22 μm											
<b>Sonotrode 2:</b>											
Power = 500 W											
Frequency = 43 kHz	22.5	22.7	23.0	23.2	23.4	24.3	24.7	25.3	25.9	26.7	
Starting temperature = 22 °C											
Amplitude = 4 μm											



**Figure 5** Graphical representation of the evolution of the temperature of the liquid environment of macerated sea buckthorn, during the ultrasound process

## RESULTS AND DISCUSSION

From table 2, but it is more obvious in the graphic representation and figure 6, the fact that in the case of the first sonotrode (1), a higher temperature is generated in the ultrasonically activated liquid medium, with a greater risk of exceeding the imposed limit of 45 °C. Under this aspect, the greater utility of the technical ultrasound system variant, using sonotrode 2, is proven. After the evaluation of the ultrasonic liquid samples, which continued the volatile oil extraction process, the assessments were favorable also oriented towards those made using sonotrode 2. Based on these research results, the most suitable constructive form was defined for the sonotrode, which would constitute the active component in the process of ultrasound processing of the liquid resulting from the maceration of sea buckthorn fruits. The shape and dimensional elements of the chosen constructive solution are shown in figure 6.



**Figure 6** The construction details of the sonotrode designed for the extraction of volatile oils from sea buckthorn:  
**a)** 3D model sonotrode; **b)** fabricated sonotrode

The operating parameters of the technical ultrasound system, related to sonotrode 2, were also defined: frequency 43 kHz, power 500 W, starting temperature, of the ambient environment, but not higher than 22 °C, working amplitude 4  $\mu\text{m}$ .

Analyzing the method of ultrasonic processing in order to extract the volatile oil of sea buckthorn, based on the original constructive solution adopted, the advantages of the process, compared to other known ones, of ensuring the conditions for achieving more durable extractions and superior quantitative capacity, were confirmed, high quality, a very low impact on the environment and on human health, allows the use of alternative solvents that are more "friendly" with the environment, a lower consumption of energy and time, premises for a better isolation of the bioactive compounds from sea buckthorn, safer products, as the specialty literature states, such as (Chaudhari, 2017) and (Putnik and Lorenzo, 2018).

## CONCLUSIONS

Following the use of the design program and the finite element simulation, technical models were developed based on which two special sonotrodes for extractions in liquid medium were created and optimized in our own laboratories.

In the experimental program, experimental laboratory models were used with operating frequencies of 20 kHz and 43 kHz respectively for sea buckthorn samples.

Research on ultrasonic extraction of volatile oils from sea buckthorn has shown that for the frequency of:

- 20 kHz, power of 3000 W, amplitude factor of 22  $\mu\text{m}$ , starting temperature is 23 °C, the samples were subjected to ultrasonic extraction for 10 min, the temperature being continuously monitored, reaching values between: 25.2-37.4 °C;
- 43 kHz, power of 500 W, amplitude factor of 4  $\mu\text{m}$ , starting temperature is 22 °C and values between: 22.5-26.7 °C.

We conclude that the thermal input induced by the sonotrode in the liquid medium in the case of extraction using the frequency of 20 kHz is significantly higher than in the case of extraction using the frequency of 43 kHz. The heat input induced to the liquid medium in the case of extraction with the frequency of 20 kHz is approximately 1.4 °C/min. This indicates that a long extraction time is to be avoided, as the temperature could reach too high values, thus damaging the vegetable oils. That is why it is chosen to use the frequency of 43 kHz to extract vegetable oils from sea buckthorn leading to an increased amount of volatile oils extracted from the samples, benefits in increased mass transfer, better solvent penetration, less dependence on the solvent used, extraction at lower temperatures, faster extraction rates and higher product yields.

The obtained results are made available for industrial exploitation, with real contributions to the improvement of technologies for the advanced processing of vegetable resources from fruit and viticulture, to obtain nutraceutical products with high added value.

## ACKNOWLEDGEMENTS

The research is part of a Romanian national research program, "Increasing the institutional capacity of bioeconomic research for the innovative exploitation of native plant resources, in order to obtain horticultural products with high added value", BIOHORTINOV - 6PCCDI/2018, Project component 4: Study regarding the realization of advanced processing procedures of plant resources from fruit and viticulture, to obtain nutraceutical products with high added value".

## REFERENCES

- Alexandre E., Moreira, S., (2018) Emerging technologies to extract high added value compounds from fruit residues: sub/supercritical, ultrasound, and enzyme-assisted extractions, *Food Reviews International*, (34) 6.
- Amza, Gh., (2016), *Ultrasunete – aplicații active*, ed. Agir.
- Arvanitoyannis, I., Kotsanopoulos, K., (2015), Use of Ultrasounds in the Food Industry - Methods and Effects on Quality, Safety and Organoleptic Characteristics of Foods: A Review, *Food Science and Nutrition*, (1) 57.
- Asofiei, I., Călinescu, I., A Semi (2019) Continuous Process for Polyphenols Extraction from Sea Buckthorn Leaves, *Scientific Reports* 9, 12044.
- Bal, M., Meda, V., (2011), Sea buckthorn berries: A potential source of valuable nutrients for nutraceuticals and cosmeceuticals, *Food Research International*, 44, 1718–1727.

- Bansal, M., Singh, N., (2018), *Advances in Molecular Toxicology*, Volume 12 Pages 69-121, 2018; <https://www.sciencedirect.com/science/article/pii/>
- BIOHORTINOV, project, <http://www.biohortinov.ro>, last accessing Dec. 2022.
- Chaudhari, S., (2017), *Nutraceuticals: A Review*, *World journal of pharmacy and pharmaceutical sciences*.
- Coman, V., Teleky, B., (2019), *Bioactive potential of fruit and vegetable wastes*, *Advances in food and nutrition research*, ISSN 1043-4526.
- <https://hypericumimpex.ro/catina-alba-studii-si-recomandari>; last accessing Dec., 2022.
- Dobrin, E., Iacobici, R.I., (2021), *Investigations regarding the application of ultrasound for the extraction of resveratrol from vegetable waste from viticulture*, *World journal of pharmacy and pharmaceutical science*, vol. 10, Issue 8, 91-101, ISSN 2278-4357.
- Hempel, <https://www.hempel-metals.co.uk/en/material/titanium-alloys/grade-5-37165/>, last accessing Nov. 2022.
- Isopencu, G., Stroescu, M., (2018), *Optimization of ultrasound and microwave assisted oil extraction from sea buckthorn seeds by response surface methodology*, *Journal of food process engineering*, 42 (2).
- Kehinde, B., Sharma, P., (2020), *Recent nano-, micro- and macrotechnological applications of ultrasonication in food-based systems*, *Critical Reviews in Food Science and Nutrition*, 61 (4).
- Khoddami, A., Wilke, M., (2013), *Techniques for Analysis of Plant Phenolic Compounds*, ISSN 1420-3049, 2013; [www.mdpi.com/journal/molecules](http://www.mdpi.com/journal/molecules)
- Knorr, D., Froehling, A., (2011), *Emerging technologies in food processing*. *Annual Review of Food Science and Technology*, (2) 203-235.
- Kyriakopoulou K., Pappa A., (2013), *Effects of Drying and Extraction Methods on the Quality and Antioxidant Activity of Sea Buckthorn, Berries and Leaves*, *Drying Technology: An International Journal*, 31(9), 1063-1076.
- Majid, I., Gulzar, A., (2015), *Ultrasonication and food technology: A review*, *Cogent Food & Agriculture*, 1.
- Mingyue, J., Gong, X., (2020), *Advanced Research on the Antioxidant Activity and Mechanism of Polyphenols from Hippophae Species - A Review*, *Molecules*, 25 (4), 25 917.
- Putnik, P., Lorenzo, M., (2018), *Novel Food Processing and Extraction Technologies of High-Added Value Compounds from Plant Materials*, *journal Foods*, 7(7), 106.
- Rousi, A., (1971), *The genus Hippophaë L. A taxonomic study*, *Annales Botanici Fennici* 8, 177-227.
- Shams, A., Abdel-Azim, S., (2015), *Green technology: Economically and environmentally innovative methods for extraction of medicinal & aromatic plants (MAP) in Egypt*, *Journal of Chemical and Pharmaceutical Research*, 7(5):1050-1074, 2015.
- Tlais A., Fiorino G., (2020), *High-Value Compounds in Fruit, Vegetable and Cereal Byproducts: An Overview of Potential Sustainable Reuse and Exploitation*, *Molecules* 2020, 25(13), 2987, 2020. <https://www.mdpi.com/1420-3049/25/13/2987/htm>



## INFLUENCE OF NITROGEN FERTILIZATION ON THE RUPTURE FORCE OF MAIZE KERNELS

Matija BALALA<sup>1</sup>, Igor KOVAČEV<sup>2</sup>, Lepomir ČOGA<sup>3</sup>, Sanja SLUNJSKI<sup>3</sup>, Fabio CELLA<sup>4</sup>,  
Stjepan SITO<sup>2</sup>, Željko JUKIĆ<sup>5\*</sup>

\*E-mail of corresponding author: zjukic@agr.hr

<sup>1</sup>Ms student at University of Zagreb Faculty of Agriculture, Svetošimunska cesta 25, 10000 Zagreb, Croatia

<sup>2</sup>Department of Agricultural Engineering, University of Zagreb Faculty of Agriculture, Svetošimunska cesta 25, 10000 Zagreb, Croatia

<sup>3</sup>Department of Plant Nutrition, University of Zagreb Faculty of Agriculture, Svetošimunska cesta 25, 10000 Zagreb, Croatia

<sup>4</sup>Agrosistemi s.r.l. Via Del Capitolo 54, 29122 Piacenza, Italy

<sup>5</sup>Department of Field Crops, Forage and Grassland, University of Zagreb Faculty of Agriculture, Svetošimunska cesta 25, 10000 Zagreb, Croatia

### ABSTRACT

*Nitrogen fertilization affects maize yield as well as the physical and mechanical properties of the kernel and kernel breakage susceptibility. The aim of this study was to determine the influence of different fertilization treatments on the magnitude of the rupture force that causes maize kernel breakage. The research was conducted on the kernels of one maize hybrid that was grown under 8 treatments of nitrogen fertilization. The results showed that round kernels were more sensitive to breakage than flat kernels. The average force required to break flat kernels ranged from 609.6 N to 995.3 N, and for round kernels from 209.7 N to 269.9 N. As the amount of added nitrogen increased, the force required to break the grains increased. Statistical analysis of the obtained results showed no significant difference in the rupture force between fertilization treatments, both for flat and round kernels. Considering the obtained results, it would be necessary to use more hybrids in such studies, to carry out studies at different grain moisture contents and in addition, to study the interaction between hybrids, nitrogen fertilization and the influence of weather conditions during the growing period on the breakage of maize kernels.*

**Keywords:** breakage, kernel, maize, nitrogen fertilization, rupture force

## INTRODUCTION

Breakage susceptibility is defined as the potential for kernel fragmentation or breakage when subjected to impact force during handling and transport (AACC, 1983). Breakage resistance of corn can be defined as the ability of the kernels to safely withstand various stresses during conditioning, handling, and transportation (Gunasekaran and Paulsen, 1985). Chen et al., (2020.) stated that grain kernel damage causes physical and physiological changes in grain kernels that reduce the grain quality, lead to various challenges during downstream processes (e.g., planting, storage, and food processing), and cause significant yield and commercial losses. According to Wang and Wang (2019.) mechanical damage of maize kernel caused by external forces during processing is closely related to its internal mechanical properties. The structure of the kernel has a great influence on the breaking strength. A maize kernel is composed of three major parts: seed coat (pericarp), endosperm, and germ (embryo). The strength and thickness of the seed coat (pericarp) is one of the main factors affecting the kernel resistance to breakage (hybrid property).

Each hybrid differs in the thickness of the pericarp, according to Helm and Zuber (1969). In their studies, the authors found that the thickness of the pericarp ranges from 62 to 160  $\mu\text{m}$ . In addition to the pericarp, the susceptibility to breakage is also influenced by the endosperm, i.e. its structure. Higher kernel weight and volume also contribute to kernel resistance to breakage (Bauer and Carter, 1986). One of the factors affecting kernel breakage is nitrogen fertilization, and the interaction between genotype, nitrogen fertilization, and weather conditions during the growing season should not be neglected. Durante et al. (2005) present the following conclusion according to which the application of nitrogen increased the hardness of the endosperm and to a lesser extent reduced the susceptibility to breakage, while genotype has a much greater influence on grain quality parameters. Kim (2000) cites Hamilton et al. (1951) and Ahmadi (1991), who found a positive relationship between kernel nitrogen concentration and kernel hardness and between kernel protein content (zein) and kernel hardness. The aforementioned authors, cited by Kim (2000), also concluded that high amount of nitrogen in the soil increases total kernel hardness due to higher kernel nitrogen concentration, which results in lower kernel susceptibility to breakage in most hybrids. Sabata and Mason (1992) state that soil nitrogen content has become a more important variable when considering kernel breakage in relation to hybrid selection.

Bauer and Carter (1986); Sabata and Mason (1992); Oikeh et al. (1998) found that kernel hardness and density or their values were not constant with increasing amount of added nitrogen at all locations and throughout all years of research on one hybrid. As noted by Sabata and Mason (1992) and Oikeh et al. (1998), it is difficult to give a general recommendation for adding nitrogen to the soil that will achieve the desired physical quality for a specific end use such as dry milling because of the different interactions between the hybrid and the environment. Bauer and Carter (1986) stated that protein content in the kernel increased with the increase in the amount of added nitrogen, which resulted in higher zein content in the kernel and a higher proportion of vitreous (hard) endosperm. Shifting sowing dates from the optimal ones, by increasing plant population (plant density) and a smaller amount of added nitrogen increased kernel breakage susceptibility. According to Kneip and Mason (1989), increasing the amount of nitrogen in the soil resulted in lower susceptibility to breakage in all hybrids studied. The authors conducted research to determine if irrigation and the amount of nitrogen added to the soil could affect grain quality. They used five levels of nitrogen fertilization (from 0 to 360 kg N ha<sup>-1</sup>), two regimes of water addition (irrigation), and two



normal and two opaque-2 hybrids. The authors found that the kernels of the opaque-2 hybrids were 2.4 times more susceptible to breakage and had 8% lower density than the kernels of the normal hybrids. Addition of irrigation water increased breakage from 13.5% to 17.9% in 1985, from 3.2% to 3.8% in 1986, and from 5.4% to 7.3% in 1987. Nitrogen fertilization significantly increases grain yield, protein concentration in the grain, and protein yield per unit area (MacGregor et al., 1961). Oikeh et al. (1998) also concluded that increasing the amount of nitrogen added resulted in an increase in grain yield, kernel weight, and kernel protein content in all hybrids studied. The objective of their study was to determine the influence of the amount of added nitrogen on some qualitative properties of corn kernels. The authors conducted research on 5 maize cultivars and 4 levels of nitrogen fertilization (0, 30, 60, and 120 kg ha<sup>-1</sup>) in 1993 and 1994 in northern Nigeria. The susceptibility of maize kernels to breakage is also influenced by moisture content. The force required to break a kernel depends on moisture content, kernel type, kernel shape, and kernel position during analysis (Verma and Prasad, 2000; Shabazi and Shabazi, 2018; Guo et al., 2022; Kruszelnicka et al., 2022). Determination of the mechanical properties (rupture force, deformation, hardness, and toughness) of maize grain could be a significant concern for designing the harvester, thresher, and handling, processing, and storage equipment (Chandio et al., 2021). Tarighi et al. (2011) studied the magnitude of forces required to break maize kernels. The study was conducted on maize kernels whose moisture content ranged from 5.15% to 22%. The authors found that as the moisture content of the grain increased from 5.15% to 22%, the force required to break the kernel decreased (from 347.5 N to 226 N).

Maize kernels can be classified according to their shape into (Banaj et al., 2021): medium flat, medium round, large flat and large round. Factors that influence kernel breakage susceptibility are: kernel size (Kruszelnicka, 2021), kernel shape (Martin et al., 1987), kernel weight (Bauer and Carter, 1986), and kernel density. Moes and Vyn (1988) state that there is no significant relationship between kernel breakage susceptibility and kernel weight and test weight. The physical properties of corn kernels gradually deteriorate from harvest to processing. Damaged grain is a product that is not desirable for farmers, buyers, processors and end users. Breakage is important because small fragments affect price by influencing grade-determining factors such as test weight and broken corn and foreign material (BCFM), according to Martin et al. (1987). The same authors noted that small grain fragments and BCFM segregate during storage bin filling and create resistance to air flow in stored grain. Without adequate air movement to control temperature and moisture, the segregated material promotes the development of molds and insects. During storage, grain is damaged during handling, creating dust and creates conditions for the occurrence of fire and explosions in the warehouse. When lower quality grain is used, production decreases in dry and wet milling (LeFord and Russell, 1985). Agricultural engineers have conducted research to develop equipment that reduces physical damage of the kernel. Developments include harvesters with an axial threshing system, drying with co-current movement of grain and warm air in the dryer, drying in a silo (dryeration), and devices for slowing down the flow of grain. Another approach, less explored is the development of a tougher, more resilient kernel resistant to breakage through genetic modification. All of the above is aimed at reducing grain spoilage and improving product quality (LeFord and Russel, 1985). Nitrogen fertilization affects not only the grain yield of corn, but also the physical and mechanical properties of the grains.

How resistant the kernel of a certain hybrid will be to mechanical influences during harvest, transportation, and processing also partly depends on nitrogen fertilization. The aim of this study was to determine the influence of different fertilization treatments on the magnitude of the rupture force that causes maize kernel breakage. The research will be carried out on one maize hybrid under laboratory conditions, and the results obtained will help in an even more precise clarification of the relationship between nitrogen fertilization and the mechanical properties of maize.

## MATERIALS AND METHODS

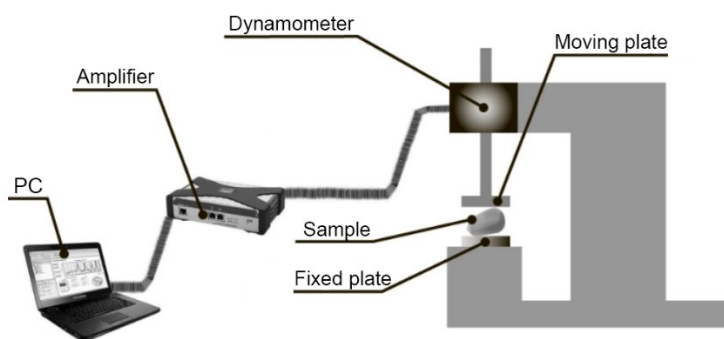
A field study was conducted at the University of Zagreb Faculty of Agriculture, at the Maksimir experimental station which is part of the Department of Field Crops, Forage and Grassland in 2021. The hybrid grown in the study included one dent hybrid (PO725, FAO maturity group 570, hard endosperm, Pioneer, Corteva agrosience). The fertilization trial included a total of eight (8) different treatments as described in Table 1. The experimental design was a randomized block with four replicates (32 plots total). The fertilization trial included mineral fertilizers and Biosulfat plus. Biosulfat plus is commercial name for soli improver.

**Table 1** Treatments and N application rate in fertilization trial

	Treatment	N application rate (kg ha <sup>-1</sup> )
1	Control	0
2	Mineral fertilizers	250
3	Biosulfat Plus	150
4	Biosulfat Plus	200
5	Biosulfat Plus	250
6	50% Biosulfat Plus 50% Mineral fertilizers	150
7	50% Biosulfat Plus 50% Mineral fertilizers	200
8	50% Biosulfat Plus 50% Mineral fertilizers	250

Plots were hand harvested by removing ears and mechanically shelled using a grain harvester. The average moisture content of the harvested grains was 21 to 23%. Following shelling 300-gram sample from each plot was taken for kernel moisture determination and for rupture force determination. Also, from 300-gram samples was taken 20 gram subsamples for determination total grain N (Kjeldahl, approved method AOAC, 2015) and protein content. Total grain N and protein content were determined in the analytical laboratory of the Department of Plant Nutrition, University of Zagreb Faculty of Agriculture. From 300-gram samples removed all impurities and broken kernels because for determination rupture force

kernels must be unbroken and without visible cracks and fissures (free of stress cracks). Kernel samples from each plot were dried at room temperature for 4 weeks until kernels reached a moisture content of approximately 10%. Thereafter, kernel samples were stored in a dry room at room temperature in paper bags. Prior determination rupture force, from samples were taken 10-gram subsample for moisture determination, and 10 round and 10 flat kernels hand-picked from all samples for testing. Kernel moisture was determined in an oven at 130°C for 90 minutes. Hand-picked round and flat kernels were examined in detail under bright light and magnifying glass, and after that determination of rupture force started. The determination of rupture force made in the laboratory of the Department of Agricultural Engineering University of Zagreb Faculty of Agriculture For determination of rupture force following equipment was used: Dynamometer HBM (Hottinger Baldwin Messtechnik GmbH, Darmstadt, Germany), measuring amplifier and converter HBM Quantum MX 840 B, connected to a personal computer (Figure 1).



**Figure 1** Equipment for measuring rupture force

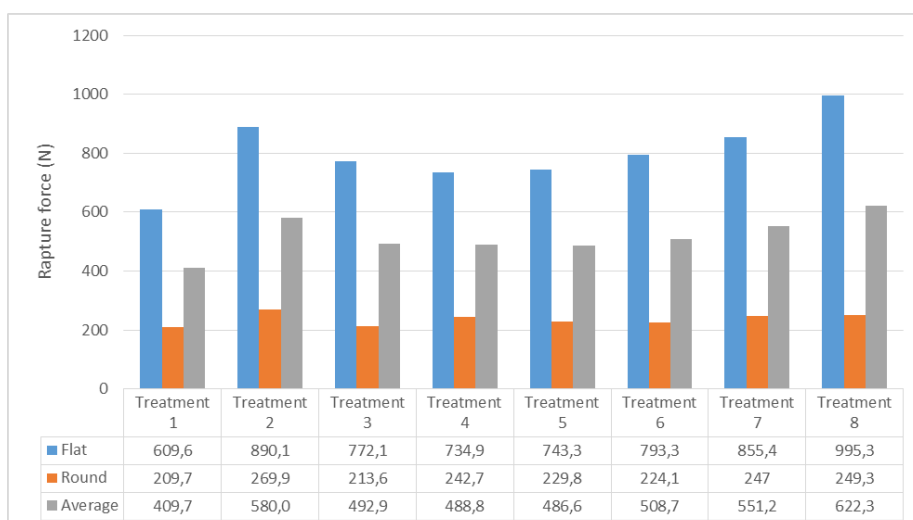
Maize kernel was placed between two parallel plates and compressed. The kernel was placed on the bottom plate, which was static, and in such a way that the germ was facing down (germ side down). The upper plate was moved down by hand, and the force at which the grain was broken was determined. The force applied to the kernel was recorded with the dynamometer until kernel ruptured. Statistical data analysis was performed using SAS software (SAS Institute, 2004).

## RESULTS AND DISCUSSION

Statistical analysis of the obtained results showed no significant difference in the rupture force between fertilization treatments, both for flat and round kernels. On average, the highest rupture force was observed in flat kernels that were grown in fertilization treatment 8 (995.3 N), which is 63% more compared to flat kernels that were grown in fertilization treatment 1 (609.6 N). This can be explained by the fact that in fertilization treatment 1 there was no added nitrogen through fertilization and the kernel was more sensitive to breakage

than in fertilization treatment 8, where through the combination of 50% Biosulfate Plus and 50% mineral fertilizer added of 250 kg N ha<sup>-1</sup>. Rupture force for round kernels was lower compared to flat kernels and on average, the highest rupture force was found for round kernels grown in fertilization treatment 2 (269.9 N), which is 29% more compared to round kernels grown in fertilization treatment 1 (209.7 N; Figure 2). In fertilization treatment 2, 250 kg N ha<sup>-1</sup> was added by mineral fertilizer, which certainly affected the increase in rupture force. It can be noted that the difference between the average maximum and average minimum rupture force was smaller for round kernels.

Based on the average value for rupture force for each fertilization treatment (rupture force for both round and flat kernels), it can be concluded that the hardest kernels were on fertilization treatment 8 (rupture force average 622.3 N, Figure 2), which was fertilized with a combination of 50% Biosulfate Plus and 50% mineral fertilizer with a total amount of 250 kg N ha<sup>-1</sup>.



**Figure 2** Average rupture forces for flat and round kernels in investigation

On average, a higher rupture force was observed in flat kernels grown in fertilization treatment 3 compared to fertilization treatments 4 and 5. At fertilization treatments 3, 4 and 5, only Biosulfat plus was used for fertilization, and as expected, the highest average rupture forces should have been determined in treatment 5, in which the highest amount of nitrogen was added (250 kg N ha<sup>-1</sup>).

However, the highest rupture forces in average were found in fertilization treatment 3. In the case of flat kernels, the magnitude of rupture forces increases from fertilization treatment 6 to fertilization treatment 8. On average the highest rupture force was found in round kernels grown in fertilization treatment 4 compared to fertilization treatments 3 and 5. Similar to the case of flat kernels, the highest rupture force was not found in the fertilization treatment with the highest amount of nitrogen was added.

It can be concluded that with an increase in the amount of nitrogen added through Biosulfat plus, rupture force decreases in the case of flat kernels, and slightly increases in the case of round kernels.

For round kernels, a slight increase in rupture force is also visible from fertilization treatment 6 to fertilization treatment 8 (figure 2). In the end, it can be concluded that even in the case of flat and round kernels, with an increase in the amount of nitrogen added in a combination of 50% Biosulfat Plus and 50% mineral fertilizer, grain resistance to breakage also increases.

Before measuring the rupture force, moisture was determined in grain samples from which 10 kernels were taken. On average, the moisture content of flat kernels ranged from 9.80 to 10.79% and for the round kernels between 9.67 to 10.54% (Table 2). No significant difference in moisture content was found between fertilization treatments for both for flat and round kernels (Table 2).

**Table 2** Average kernel moisture, minimum (Min) and maximum (Max) rupture forces and standard deviation (STDEV) for flat and round kernels

Treatment	Flat kernels				Round kernels			
	Average kernel moisture (%)	Rupture force			Average kernel moisture (%)	Rupture force		
		Min (N)	Max (N)	STDEV		Min (N)	Max (N)	STDEV
1	10.01	257.5	1457.5	231.4	9.81	89.2	573.8	22.8
2	9.80	366.8	1679.4	140.5	9.67	122.1	555.9	32.5
3	10.05	253.6	1546.2	87.6	10.03	114.1	459.2	27.9
4	10.24	322.1	1416.3	155.4	10.13	133.3	463.3	27.3
5	9.86	331.6	1786.6	117.8	10.16	95.4	604.6	44.1
6	10.18	359.5	1620.7	179.6	9.91	79.9	466.9	26.1
7	10.79	304.9	1989.8	223.3	10.54	121.6	589.6	21.7
8	10.38	320.4	1690.7	135.6	10.09	153.0	526.1	22.6

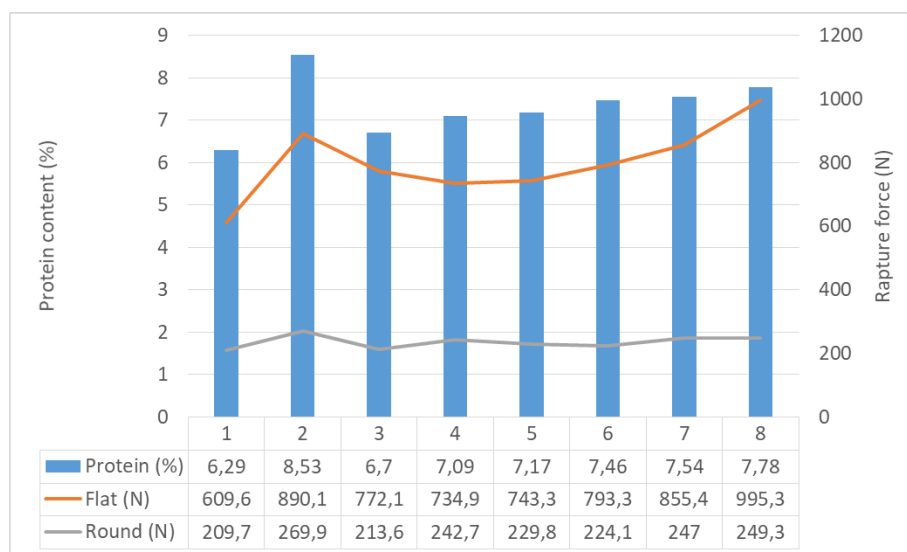
For flat kernels the smallest difference in average rupture force was found between fertilization treatment 4 and fertilization treatment 1 (125.3 N). The largest difference between minimum and maximum rupture force for flat kernels was found in fertilization treatment 7, and the smallest difference in fertilization treatment 4. The largest standard deviation was in fertilization treatment 1, and the smallest in fertilization treatment 3 (Table 2). For round kernels the smallest difference in average rupture force was found between fertilization treatment 3 and fertilization treatment 1 (3.9 N). The largest difference between minimum and

maximum rupture force for round kernels was found in fertilization treatment 5, and the smallest difference, as with flat ones, was found in fertilization treatment 4. The largest standard deviation was found in fertilization treatment 5, and the smallest in fertilization treatment 7 (Table 2).

From all of the above, it can be concluded that round kernels have higher susceptibility to breakage compared to flat kernels, which is also found in the literature. Indeed, Miller et al. (1981) state that large round kernels are more susceptible to breakage than smaller round or flat kernels. LeFord and Russel (1985) also found that kernels which is more resistant to breakage were smaller, denser, and had higher shear strength.

Although the protein content and hardness of the kernels were not directly determined in this study, they are related to the amount of added nitrogen. For this reason, we requested and obtained data on the nitrogen content of the kernels from the analytical laboratory of the Department of Plant Nutrition for this study.

In fact, the study of the magnitude of the rupture force was carried out on grain samples grown in a fertilization trial set up and managed by scientists from the Department of Field Crops, Forage and Grassland and the Department of Plant Nutrition to determine the effect of maize fertilization with the soil improver under the commercial name Biosulfat plus on yield and quality. The average rupture forces for flat and round kernels and kernel protein content are shown in Figure 3.



**Figure 3** Average rupture forces for flat and round kernels and kernel protein content

From Figure 3, it can be seen that with an increase in protein content, grain strength and grain resistance to breakage change. Fertilization treatment 1 had the lowest grain strength and grain resistance to breakage due to the lowest protein content in the kernel. The data from Figure 3 confirm the results of numerous studies that have demonstrated that nitrogen

fertilization affects protein content, i.e., increasing the amount of added nitrogen also increases the protein content of the grain (Genter et al., 1956; Jellum et al., 1973; Oikeh et al., 1998) and the kernel density (Paulsen et al., 1983; Gerde et al., 2017; Barrios Sanchez et al., 2019). It is also known that a harder grain is more resistant to breaking.

## CONCLUSION

Based on the results obtained from the research, it can be concluded that nitrogen fertilization has an effect on the magnitude of the rupture force. By increasing the amount of added nitrogen kernel protein content and rupture force increased. There is a difference between different kernel shapes in the rupture forces and flat kernels requiring more force to break than round kernels. Considering that only one hybrid was used in the study, it would be necessary to use more hybrids in future studies, conduct studies at different grain moisture levels, and additionally study the interaction between hybrids, nitrogen fertilization and the influence of weather during the growing season on grain breakage.

## REFERENCES

- AACC. (1983). Corn breakage susceptibility. AACC method 55-20. In *Approved methods of the American Association of Cereal Chemists*. Vol. II. AACC, Minneapolis, MN.
- Banaj, A., Banaj, Đ., Petrović, D., Stipešević, B., i Tadić, V. (2021). Utjecaj frakcija zrna kukuruza i tehničkih čimbenika podešavanja na kvalitetu rada sijačice PSK 4. *Poljoprivreda*, 27:11-21.
- Barrios Sanchez, M.G., Rodriguez Yzquierdo, G.A., Alvarez Escobar, M.G. (2019). Effect of nitrogen-sulfur fertilization on yield and quality of three corn genotypes differing in endosperm texture. *Cienc. Tecnol. Agropecuaria* vol.20 no.3 Mosquera Sep./Dec. 2019 Epub Sep 10, 2019. <https://doi.org/10.21930/rcta.vol20num3art:1591>
- Bauer, P.J., Carter, P.R. (1986). Effect of seeding date, plant density, moisture availability, and soil nitrogen fertility on maize kernel breakage susceptibility. *Crop. Sci.* 26:1220-1226.
- Chandio, F.A., Yaoming, L., Zheng, M., Fiaz, A., Tabinda Naz, S., Sher Ali, S., Mazhar Husain, T. (2021). *International Journal of Agricultural and Biological Engineering; Beijing*, Vol.14, Iss.5, (Sep2021):41-49. DOI:10.25165/j.ijabe.20211404.6072
- Chen, Z., Wassgren, C., Kingsly Ambrose, R.P. (2020). A review of grain kernel damage: mechanisms, modeling, and testing procedure. *Transactions of the ASABE* Vol. 63(2): 455-475 © 2020 American Society of Agricultural and Biological Engineers ISSN 2151-0032 <https://doi.org/10.13031/trans.13643>
- Durante, A.P., Mason, S.C., Jackson, D.S., Kiehl, J. de C. (2005). Grain Quality of Brazilian Maize Genotypes as Influenced by Nitrogen Level, *Crop Sci.* 45:1958-1964.
- Genter, C.G., Eheart, J.F., Linkous, W.N. (1956). Effect of location, hybrid, fertilizers, and rate of planting on the oil and protein content of corn grain. *Agronomy Journal* 48:63-67.
- Gerde, J.A., Spinozzi, J.I., Borrás, L. (2017). Maize Kernel Hardness, Endosperm Zein Profiles, and Ethanol Production. *Bioenerg. Res.* (2017) 10:760-771. DOI 10.1007/s12155-017-9837-4.
- Gunasekaran, S., Paulsen, M.R. (1985). Breakage Resistance of Corn as a Function of Drying Rates. *TRANSACTIONS of the ASAE*, Vol. 28(6): November-December, 1985, 2071-2076. <https://foodeng.wisc.edu/images/publications/1999-59.pdf>

- Guo, Y; Hou, L; Li, L; Gao, S; Hou, J; Ming, B; Xie, R; Xue, J; Hou, P; Wang, K; et al. (2022). Study of Corn Kernel Breakage Susceptibility as a Function of Its Moisture Content by Using a Laboratory Grinding Method. *J. Integr. Agric.* 2022, 21, 70–77. DOI: 10.1016/S2095-3119(20)63250-6
- Helm, J. L., Zuber, M.S. (1969). Pericarp thickness of dent corn inbred lines. *Crop Science* 9: 803-804.
- Jellum, M.D., Boswell, F.C., Young, C.T. (1973). Nitrogen and boron effects on protein and oil of corn grain. *Agronomy Journal* 65:330-331.
- Kim, T.H. (2000). Physical changes in maize (*Zea mays* L.) grains during postharvest drying. A thesis presented in partial of the requirements for the degree of Doctor of Philosophy in Seed technology at Massey University, 2000.  
<https://mro.massey.ac.nz/bitstream/handle/10179/2375/02>
- Kneip, K. R., Mason, S. C. (1989). Kernel breakage and density of normal and opaque-2 maize grain as influenced by irrigation and nitrogen. *Crop Science* 29:158-163.
- Kruszelnicka, W. (2021). Study of Selected Physical-Mechanical Properties of Corn Grains Important from the Point of View of Mechanical Processing Systems Designing. *Materials* 2021, 14(6), 1467; <https://doi.org/10.3390/ma14061467>
- Kruszelnicka, W., Chen, Z., Ambrose, K. (2022). Moisture-Dependent Physical-Mechanical Properties of Maize, Rice, and Soybeans as related to Handling and Processing. *Materials* 2022, 15, 8729. <https://doi.org/10.3390/ma15248729>
- LeFord, D.R., Russell, W.A. (1985). Evaluation of physical grain quality in the BS17 and BS1(HS)C1 synthesis of maize. *Crop. Sci.* 25:471-476.
- MacGregor, J. M., Taskovitch, L. T., Martin, W. P. (1961). Effect of nitrogen fertilizer and soil type on the amino acid content of corn grain. *Agronomy Journal*, 53:211-214.
- Martin, C. R., Converse, H.H., Czuchajowska, Z., Lai, F. S., Pomeranz, Y. (1987). Breakage susceptibility and hardness of corn kernels of various sizes and shapes. *Applied Engineering in Agriculture* 3:104-113.  
<https://www.ars.usda.gov/ARUserFiles/30200525/173>
- Miller, B. S., Hughes, J. W., Rousser, R., Pomeranz, Y. (1981). Measuring the breakage susceptibility of shelled corn. *Cereal Foods World* 26: 75-80.
- Moes, J., Vyn T.J. (1988). Management Effects on Kernel Breakage Susceptibility of Early Maturing Corn Hybrids. *Agronomy Journal* 80:699-704.
- Oikeh, S. O., Kling, J. G., Okoruwa, A. E. (1998). Nitrogen fertilizer management effects on maize grain quality in the West African moist savanna. *Crop Science* 38:1056-1061.
- Paulsen, M.R., Hill, L.D., White D.G., Sprague G.F. (1983). Breakage susceptibility of corn-belt genotypes. *Trans. ASAE* 32:1007-1014.
- Sabata, R. J., Mason, S. C. (1992). Corn hybrid interactions with soil nitrogen level and water regime. *Journal of Production of the Agriculture* 5:137-142.  
<https://doi.org/10.2134/jpa1992.0137>
- SAS Institute. (2004). *SAS/STAT User's Guide for Personal Computer*. SAS Institute Inc.,
- Shabazi, F., Shabazi, R. (2018). mechanical damage to corn seeds. *Cercetări Agronomice în Moldova*, Vol. LI, No. 3 (175) / 2018: 1-12. DOI: 10.2478/cerce-2018-0021
- Tarighi, J., Mahmoudi, A., Alavi, N. (2011). Some mechanical and physical properties of corn seed. *African Journal of Agricultural Research*, 6:3691-3699.  
DOI: 10.5897/AJAR10.521
- Verma, R. C., Prasad, S. (2000). Mechanical and thermal properties of maize. *Journal Food Sci. Technology*, 37:500-505. [https://www.researchgate.net/profile/Rc-Verma/publication/297790797\\_Mechanical\\_and\\_thermal\\_properties\\_of\\_maize/links/5d68f783299](https://www.researchgate.net/profile/Rc-Verma/publication/297790797_Mechanical_and_thermal_properties_of_maize/links/5d68f783299).



Wang, B., Wang, J. (2019). Mechanical properties of maize kernel horny endosperm, floury endosperm and germ. *International journal of food properties* 2019, VOL. 22, NO. 1, 863–877.

<https://doi.org/10.1080/10942912.2019.1614050>

---

---



## RESEARCH ON THE ANALYSIS OF FRUIT AND VEGETABLE JUICE YIELD

Augustina PRUTEANU, Mihaela NITU\*, Cristian SORICA

\*E-mail of corresponding author: pruteanu\_augustina@yahoo.com

INMA Bucharest, Romania

### SUMMARY

*All the variety of fresh fruits and vegetables are an important source of fibers, vitamins, minerals and antioxidants, which help to maintain beauty and youth, but also at a constant level of energy and vitality. It is recommended to consume as diverse fruits and vegetables as possible, starting in the early hours of the morning, followed by another 4-5 portions divided throughout the day. Therefore, breakfast is the most important meal at which you can successfully consume various natural juices, being not only an extremely healthy alternative, but it is one that is prepared quickly, and can be easily integrated into the daily routine.*

*The yield of the juice depends on the permeability of the cell and the viscosity of the juice, and the permeability of the cell depends on the physiological state of the plant cell, the viscosity of the juice depends on the content of pectin substances. The juice yield obtained from fruits or vegetables varies both depending on the pressing power applied and the fruit species and their state of maturity.*

*The paper presents experimental research on the analysis of the yield of juice obtained from fresh fruits (buckthorn, apple, pear, lemon, grapefruit, pineapples, grapes) and vegetables (cucumber, zucchini, ginger, beet, carrot, cabbage, celery) purchased from supermarket. The variation in time of some parameters (moisture, total soluble solids, juice yield) is presented, through the experimental and theoretical results yield obtained from apples and cucumbers, with the polynomial function of II degree.*

*The results represent an important premise for fruit and vegetable processors in the agri-food market, horticulture, as well as for the creation of specialized equipment and/or high-performance processing lines.*

**Keywords:** *apples, cucumbers, moisture, soluble solids, perishability*

## INTRODUCTION

During the pandemic, for the population of a country to be healthy, strong and productive, the nutritional status must be good. In this context, in the new millennium, consumer demand for healthy drinks with immunity-stimulating properties has increased (Mahanandia et al., 2022). The consumption of vegetable or fruit juice provides essential nutrients, such as phenolic compounds, contributing to improving and maintaining the general health of the human body and reducing the risk of chronic diseases. Diets based on vegetable or fruit juices, rich in bioactive substances, however the scientific evidence that these diets have health benefits is limited (Henning et al., 2017).

The role of fruit juice in pediatric diets is controversial due to the fact that it would induce excessive weight gain. The objective of the study (Wan et al., 2020) was to determine the relationship between fruit juice consumption in preschoolers and adolescents. The results showed that the consumption of fruit juice had beneficial effects on the body mass index for children, both during childhood and in middle adolescence.

The paper (Abuajah et al., 2015) presents a review of the bioactive compounds present in fruits and vegetables and their benefits. Thus, fruits and vegetables contain carotenoids, flavones with benefits on neutralize free radicals which may cause damage to cells, reduce the risks of muscular degeneration and of prostate cancer.

Another review of the evidence regarding the fact that fruit juices may helpful or harmful to health is presented in the paper (Ruxton and Myers, 2021). Although fruit juices are classified as a source of free sugars, their consumption and effect in a balanced diet on the health of adults and children indicate more benefits than risks, especially with regard to vascular health (in the case of regular consumption of fruit juice up to 500 ml per day) and nutrient dosing. Some food guides in the US and some countries recommend moderate consumption of fruit juice (75-224 ml per day), so it does not increase the risk of obesity, diabetes or cardiovascular disease.

In European countries, it is estimated that 1-2% is the total consumption of vegetable juice, with carrot juice accounting for 50%. On the European market, the demand for mixed vegetable juice is growing, which is combined with tomato juice or fruit juice, resulting in new products appreciated by the modern population (Kosters and Waldron, 2009).

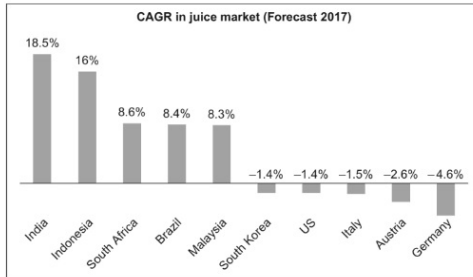
Within the EU, the composition of fruit juice, their production and labeling are regulated by the fruit juice directive (Council Directive 2001/112/EC, 2001; Codex Stan 247-2005). Soluble solids content (Brix level) from fruit juices are: apple 11.2÷11.5; pear 12; lemon 8; grapefruit 10; pineapple 12.8; grapes 16; buckthorn 6 (Mihalev et al., 2018).

The juice market is a innovative product in the food and drinks sector. The market is dependent on the geographical distribution, shown in figure 1, and availability of the fruit and vegetables, shown in figure 2 (Priyadarshini, 2018).

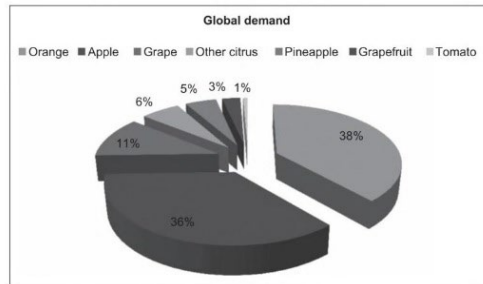
Fruit juices contain most of the carbohydrates, vitamins, dietary fiber and mineral salts of raw materials with nutritional and dietary value. Juices also have an important place in the diet of infants and children, because they provide the necessary vitamins for the body's growth (Academia, 2022).

Apart from orange juice, which remains the most popular and widely consumed fruit juice produced in the largest volume worldwide, other fruit juice types, such as pomegranate or

berry-based juices have gained a high reputation and are being sold as high-quality food items, due to their remarkable health benefits, including prevention against cancer and cardiovascular disease (Dasenaki and Thomaidis, 2019).



**Figure 1** Compound annual growth rate in the juice market: forecast for up to year 2017 (Priyadarshini, 2018)



**Figure 2** Global demand for flavors (Priyadarshini, 2018)

The chemical composition of the fruits differs from year to year, whether the year was rainy or not, from the variety of fruits, from the area from which they come and last but not least from their storage conditions. Chemical composition of apple juice (0.1% protein, 0% fat, 12% carbohydrate, 0.008% calcium, 0.07% phosphorus, 0.1% iron, 0.045% vitamin B, 2% vitamin C, 88,50% water content). Other properties of apples (specific heat 0,854-0,924; specific mass 0,6512-0,9583). Apples have less specific mass than the unit, they contain more air in their pulp than other fruits. The specific mass of fruits is an important feature for the appreciation of varieties within each species. Thus, apple varieties with a large specific mass have a longer shelf life than those with a lower specific mass. Also, the specific mass influences the variation of the fruit's external appearance during storage. It has been found that after a storage time fruits with a higher specific meal show a more attractive exterior appearance than those with a lower specific mass. This is due to the fact that in fruits with denser structure and texture, turgescence is higher than in those with rare structure and texture (Academia, 2022).

The varieties of apples, grown in our country, contain fructose between  $4.15 \div 7.85\%$ , the total sugar content of apples  $\approx 11.75\%$ . The sweet taste of fruits is influenced by acidity and tanning substances. Total acidity, in malic acid  $0.16 \div 1.27\%$ ; pH  $2.5 \div 3.7$ ; mineral substances  $0.10 \div 0.42$  g; the energy value of apples /100 g is  $39 \div 75$  kcal (Academia, 2022).

Among vegetable juices, cabbage, celery, pumpkin, eggplant, lettuce, spinach, leek and green bean juices have been studied from a microbiological stability point view, with the addition of a natural antimicrobial (Pina-Pérez et al., 2015).

A study (Habib and Iqbal, 2014) presents the processing of mixed juices of tomatoes, cucumbers and pumpkin. Different percentages of the juice of each vegetable were used, chemical, static, sensory and microbiological analysis was carried out over a period of 60 days. The changes in the juices were insignificant, with the exception of vitamin C. The color and flavor of the juices was gradually lost and the juice changed after 30 days.

Another recent study (El-Saadony et al., 2020) shows the effect of chemical additives (acids and salts) and natural additives (protein isolates) on the flavoring of cucumber juice and preservation at room temperature with low pressure, over a period of 6 months. Finally, it was recommended the utilization of natural additives because their antioxidant and antimicrobial activity, of their safety, unlike chemical ones.

The authors of the paper (Bianchi et al., 2021) studied the quality of a mixture of apple juice with beet juice (pH, soluble solids, color, betalains and antioxidant activity), obtained from local products, for storage and validity at different temperatures.

This paper presents experimental research on obtaining a maximum yield of fruit and vegetable juice extraction and theoretical on the variation in time of some parameters (moisture, total soluble solids, juice yield) from apples and cucumbers.

## MATERIALS AND METHODS

Fruit juices are products intended for direct consumption and are obtained by extracting cellular juice from fruit by pressing. From a technological point of view, fruit juices can be classified into non-pulp (clarified) and pulp (nectar) juices. Natural juices are those obtained from a single fruit (Academia, 2022).

When processing fruits and vegetables, it was established that 2 parameters (color and aroma) are essential for the production of juices. These parameters are very sensitive, in the sense that they suffer degradation when they come into contact with various unavoidable factors during processing. Among the factors that negatively influence the quality of flavorings and dyes in juices the most important are oxidation, heat and manipulations (Academia, 2022).

Especially organic acids present advantageous authenticity markers in fruit products, as they are less susceptible to alterations during juice process and/or storage, in comparison to other juice constituents. In this context, grape juice presents elevated concentrations of tartaric acid while apple juice is characterized by its high quinic acid content (Dasenaki and Thomaidis, 2019).

The experiments were conducted on seven species of fresh fruits (buckthorn, apple, pear, lemon, grapefruit, pineapples, grapes) and seven species of fresh vegetables (cucumber, zucchini, ginger, beet, carrot, cabbage, celery).

They were purchased from the local market in Bucharest, then washed and cleaned in this way before pressing, there were 8 kilograms of each species. Pressing was done cold with a fruit and vegetable juicer equipped with a screw shaft, small model.

After each fruit, the vegetable was weighed at the analytical balance the amount of juice, respectively pulp, resulting from the pressing operation (figure 3). It was considered that the pressing ended when no more juice is drained from the press, and the pressed crushing to be as dry as possible, that is, devoid of juice. The yield in regular fruit juice varies both depending on the pressing power applied and the species of fruits, vegetables and their maturity status, moisture, amount of sugars, etc.



**Figure 3** Aspects during pressing, obtaining juice and pulp

The yield in juice (%) of fruit and vegetables, respectively, was calculated using the formula (1):

$$\text{Yield juice (\%)} = \frac{M_{\text{juice}}}{M_{\text{material}}} * 100 \quad (1)$$

where:  $M_{\text{suc}}$  = the amount of raw juice that results in pressing;  
 $M_{\text{material}}$  = the initial amount of fruit/vegetables prepared for pressing.

Next, for 21 days, they were observed, at room temperature at 19-21°C, apples and cucumbers (figure 4). At 7 day intervals, the moisture and total soluble substances were weighed and analyzed, then the yield in the juice was calculated.



**Figure 4** Aspects of the evolution of apples and cucumbers over time (21 days)

**Determination of moisture content** was determined through drying in a ventilated. It was weighed about 5 g of well mixed sample (for apple respectively for cucumber) in a dish. After the samples was maintained at  $105 \pm 2^\circ\text{C}$  and dry about four hours. It was cooled in a desiccator and then it was weighed. Calculation moisture by formula (2):

$$\text{Percent by weight} = \frac{100 (M_1 - M_2)}{(M_1 - M)} \quad (2)$$

where:  $M_1$  = weight in g of dish with material before drying;  
 $M_2$  = weight in g of dish with the dried material;  
 $M$  = weight in g of empty dish.

**The total soluble solids** were determined with the Abbe refractometer by reading the Brix degrees on the graduated scale. Refractometer indicates the percentage by mass of Sucrose by means of a scale graduated in 0.5 %, in order to allow readings to be estimated to 0.25 %.

This refractometer shall be adjusted so that at 20°C it registers for distilled water a soluble solid (sucrose) content of zero.

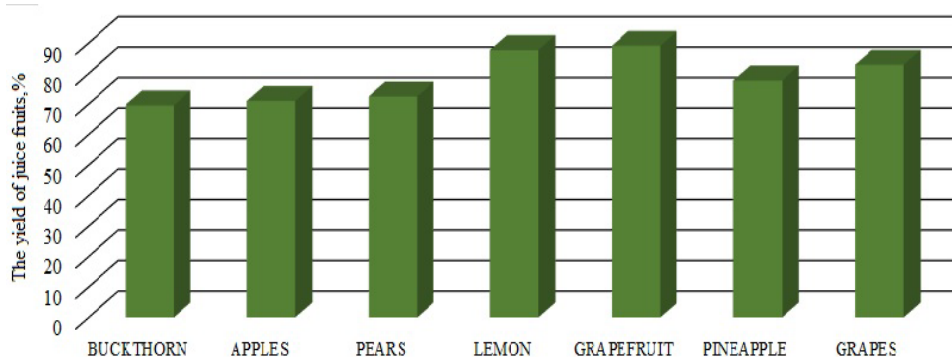
## RESULTS AND DISCUSSION

Material balance for fruits and vegetables are presented in table 1.

**Table 1** Material balance

Fruits	Juice (kg)	Fruit pulp (kg)	Vegetables	Juice (kg)	Fruit pulp (kg)
<b>Buckthorn</b>	5.56	2.44	<b>Cucumbers</b>	5.86	2.14
<b>Apples</b>	5.68	2.32	<b>Zucchini</b>	4.41	3.59
<b>Pears</b>	5.80	2.20	<b>Ginger</b>	4.62	3.38
<b>Lemon</b>	7.01	0.99	<b>Beet</b>	5.60	2.40
<b>Grapefruit</b>	7.13	0.87	<b>Carrot</b>	3.73	4.27
<b>Pineapple</b>	6.21	1.79	<b>Cabbage</b>	6.85	1.15
<b>Grapes</b>	6.63	1.37	<b>Celery</b>	3.88	4.12

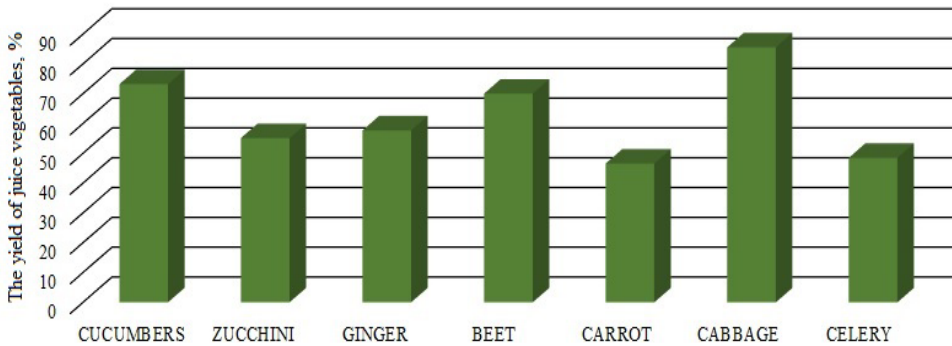
The yield in juice extracted from fruits are presented in figure 5 and from vegetables are presented in figure 6.



**Figure 5** The yield of juice extracting from fruits

For fruits, the maximum yield was obtained by grapefruit 89% and lemon 88% (so citrus fruits), followed by grapes 83% and pineapple 78%. The lowest yield values were for buck thorn 70%, apples 71%, pears 72%.



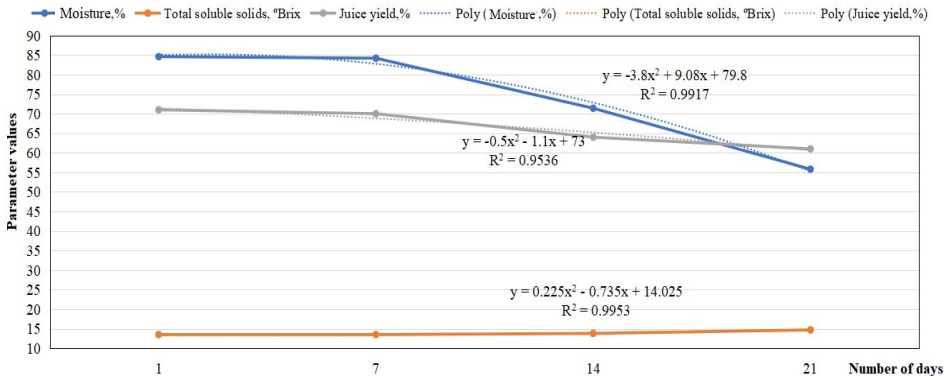


**Figure 6** The yield of juice extracting from vegetables

In the case of vegetables, the yield varies between 86% for cabbage and 47% for carrot, respectively 48% for celery (so root vegetables). It was recorded 73% for cucumbers, 70% for beets, 58% for ginger and 55% for zucchini.

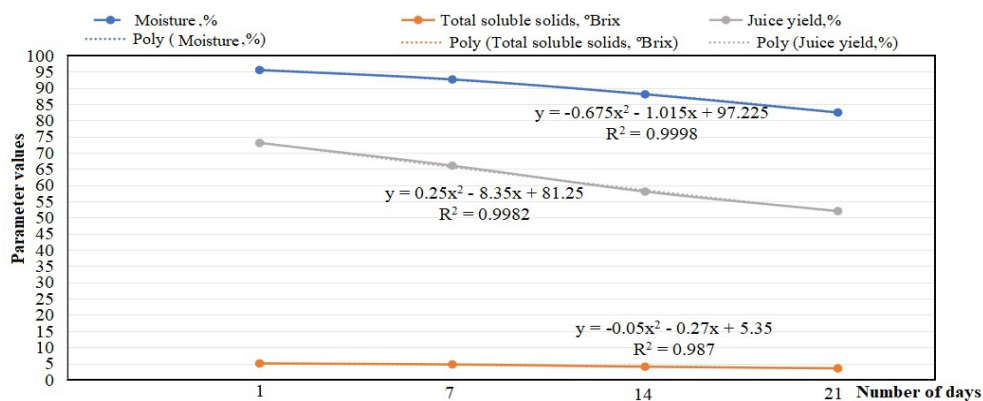
The following parameters were represented: moisture and total soluble solids, as well as the yield of juice obtained from apples, in figure 7, and from cucumbers, in figure 8.

The results obtained were interpreted for the three parameters followed (moisture, total soluble solids and juice yield), using the polynomial function of grade II, as can be seen in figures 7 and 8, the correlation coefficients of the functions having very good values  $R^2=0.9536 \div 0.9998$ .



**Figure 7** The variation in time of some parameters for apples

The conclusion was that, over time, the moisture decreases, as is normal, as well as the amount of juice, because they lose significant amount of water over time.



**Figure 8** The variation in time of some parameters for cucumbers

As for the amount of total soluble substances, it has been observed that, over time, they grow in apples, so they become sweeter, while in cucumbers, total soluble substances decrease, probably as a result of their yellowing or wilting, and the fact that they begin to bitter or change their taste.

The high moisture content in fruit and vegetable juices makes them highly susceptible to being spoiled by microorganisms. Moreover, physio chemical changes affect the safety and quality. Recent studies showed that the storage with low pressure at room temperature can be an effective technique to fruit and vegetable juices storage, as pressure inhibits the microbial content of fresh juice, besides enhancing sensory characteristics and the quality of the juice (El-Saadony et al., 2020).

Therefore, in the work (Henning, 2017) it was examined if consumption of fruit and vegetable juices (6 bottles daily of mixtures of greens, roots, citrus, lemon, cayenne and vanilla almond) for 3 days, it alters the intestinal microbiota in twenty healthy participants. The results showed that a diet based on juice can change the intestinal microbiota associated with weight loss, decrease in lipid oxidation and increase in the vasodilator.

The authors of the paper (Ruxton et Myers, 2021) recommend regular consumption of fruit juice (up to 500 ml per day) for maintaining the health of the cardiovascular system and for a diet rich in nutrients.

In the work (Mahanandia et al., 2022) is presented a study on the creation of a healthy beverage, consisting of 100% apple juice (T0), apple juice (85%) and carrot juice (15%) and ginger juice (2.5%) – (T1), apple juice (75%) and carrot juice (25%) and ginger juice (2.5%) – (T2), apple juice (65%) and carrot juice (35%) and ginger juice (2.5%) – (T3). Ginger juice has been added as standard. For each physico-chemical analysis, microbial analysis, and organoleptic characteristics were tested. Based on this mixed fruit juice the evaluation was  $T1 > T0 > T2 > T3$ . The highest mean total soluble solids was recorded as T0 (15.44 °Brix), followed by T1 (14.6 °Brix), T2 (13.68 °Brix) and T3 (13.44 °Brix). The difference between these values of total soluble solids T0 – T1, T0 – T2, T0 – T3, T1 – T2 and T1 – T3 was significant.

In a mixture of apple juice and beets, kept at different temperatures and with pH between 3.7÷6.45, sugar content values between 9.87-15.72° Brix were obtained (Bianchi et al., 2021).

It may happen that the fruits are picked at a ripe stage when they are less juicy but they can be kept until they reach a convenient state, they develop well during this time. Apples raw material for juices are harvested when they are fully ripe, healthy, ripe and unripe. This state of maturity they contain maximum amounts of sugars, aromas, are pleasant to the taste, well balanced in terms of composition, with specific characteristics of the variety. Starting from this state of maturity and processed immediately, the best juices are obtained (Academia, 2022).

## CONCLUSIONS

Fruit juices, respectively vegetables, contain most of the carbohydrates, vitamins and mineral salts of raw materials having nutritional and dietary value.

Knowing the balance of materials helps to tracing of the raw materials flow (fruits, vegetables) through a juice extraction technology and makes it possible to determine the manufacturing yield and size of the respective technology.

Based on juice yield the evaluation for fruits was:

Grapefruits>Lemons>Grapes>Pineapple>Pears>Apples>Buckthorn.

Based on juice yield the evaluation for vegetables was:

Cabbage>Cucumbers>Beet>Ginger>Zucchini>Celery>Carrot.

As regards of the evolution over time of moisture, total soluble solids and yield juice in apples and cucumbers it was found that over time the moistures and yield decrease and the total soluble solids decrease in cucumbers and increase in apples.

It is normal that over time, the fruits and vegetables kept in air lose weight, so that the juice extraction yield decreases as well.

Fact that total soluble solids decrease in cucumbers is due to the fact that microbial agents appear which causes perishability. Because cucumbers have a very high degree of humidity, perishability occurs in a fairly short time, for example compared to apples that last longer.

In apples, the total soluble solids increase probably due to the fact that they were not ripe enough and then while they ripen the total soluble solids increase.

The correlation of the theoretical and experimental data was good ( $R^2 > 0.9536$ ).

The efficiency of extracting juice from fruits and vegetables can be achieved at a high level if you take into account: pressing operation (to be carried out with specialized equipment having the parameters of the working regime chosen properly); the species and variety of fruits, respectively vegetables; how their growth and maturation took place; cultivation in different climatic and soil conditions.

The results from the work can help on the one hand to choose a healthy and balanced lifestyle and on the other hand to choose and size the machines for processing and processing fruits and vegetables.

## ACKNOWLEDGEMENT

This work was supported by a grant of the Romanian Ministry of Research, Innovation and Digitization, project code PN-III-P2-2.1-PTE-2021-0306, contract no. 87PTE/21.06.2022

## REFERENCES

- Abujah C. I., Ogbonna A. C., Osuji C. M. (2015). Functional components and medicinal properties of food: a review, *Food Sci. Technol.*, 52(5):2522–2529, DOI 10.1007/s13197-014-1396-5.
- Bianchi F., Pünsch M., Venir E. (2021). Effect of Processing and Storage on the Quality of Beetroot and Apple Mixed Juice, *Foods* 10, 1052, <https://doi.org/10.3390/foods10051>.
- Dasenaki M. E., Thomaidis N. S. (2019). Quality and Authenticity Control of Fruit Juices-A Review, *Molecules* 2019, 24, 1014; doi:10.3390/molecules24061014.
- El-Saadony M. T., Elsadek M. F., Mohamed A. S., Taha A.E., Ahmed B. M., Saad A. M. (2020). Effects of Chemical and Natural Additives on Cucumber Juice’s Quality, Shelf Life, and Safety 9, 639; doi:10.3390/foods9050639.
- Habib Md. R., Iqbal A. (2014). Processing of Mixed Vegetable Juice from Tomato, Cucumber and Pumpkin, *Food Science and Technology* 2(6): 83-91, DOI: 10.13189/fst.2014.020603.
- Henning M. S., Yang J., Shao P., Lee R.-P., Huang J., Ly A., Hsu M., Lu Q.-Y., Thames G., Heber D., Li Z. (2017). Health benefit of vegetable/fruit juice-based diet: Role of microbiome, *Scientific Reports*, 7: 2167, DOI:10.1038/s41598-017-02200-6.
- Kosters P.S.R., Waldron K.W. (2009). Handbook of Waste Management and Co-Product Recovery in Food Processing, Chapter 15 - Production of high-value functional vegetable juices from food co-products, Woodhead Publishing Series in Food Science, Technology and Nutrition, Volume 2, CRC Press, Boston New York Washington, pp. 376-390, <https://doi.org/10.1533/9781845697051.3.376>.
- Mahanandia B. K., Singh S. S., Saini N. (2022). Development and quality assessment of health beverage from apple juice blended with carrot and ginger, *The Pharma Innovation Journal*, 11(9): 1563-1567.
- Mihalev K., Dinkova R., Shikov V., Mollov P. (2018). Fruit Juices - Extraction, Composition, Quality and Analysis, Chapter 3 - Classification of Fruit Juices, Academic Press, Dublin, Ireland, pp. 33-44, <https://doi.org/10.1016/B978-0-12-802230-6.00003-5>.
- Pina-Pérez M.C., Rodrigo D., Martinez A., (2015). Handbook of Natural Antimicrobials for Food Safety and Quality, Chapter16 - Using natural antimicrobials to enhance the safety and quality of fruit- and vegetable-based beverages, Woodhead Publishing Series in Food Science, Technology and Nutrition, pp. 347-363, <https://doi.org/10.1016/B978-1-78242-034-7.00016-5>.
- Priyadarshini A., Priyadarshini A. (2018). Fruit Juices - Extraction, Composition, Quality and Analysis, Chapter 2 - Market Dimensions of the Fruit Juice Industry, pp. 15-32, <https://doi.org/10.1016/B978-0-12-802230-6.00002-3>.
- Ruxton, C.H.S.; Myers, M. (2021). Fruit Juices: Are They Helpful or Harmful An Evidence Review, *Nutrients* 13, 1815. <https://doi.org/10.3390/nu13061815>.
- Wan L., Jakkilinki P. D., Singer M. R., Bradlee M. L., Moore L. L. (2020). A longitudinal study of fruit juice consumption during preschool years and subsequent diet quality and BMI, *BMC Nutrition* 6:25, <https://doi.org/10.1186/s40795-020-00347-6>.
- \*\*\*Academia, Apple juice manufacturing technology, website: [https://www.academia.edu/32982305/Suc\\_de\\_mere](https://www.academia.edu/32982305/Suc_de_mere), accessed in October 2022.



## THE INFLUENCE OF PRECIPITATION ON THE ENERGY PROPERTIES OF WHEAT BIOMASS

Mateja GRUBOR\*, Nikola BILANDŽIJA, Ana MATIN, Vanja JURISIĆ,  
Darija BILANDŽIJA, Tajana KRIČKA

\*E-mail of corresponding author: mgrubor@agr.hr

University of Zagreb Faculty of Agriculture, Svetošimunska cesta 25, 10000 Zagreb, Croatia

### ABSTRACT

*In the coming years, energy production will require increasing amounts of biomass, and forest residues, agricultural biomass and purpose-grown biomass crops will play a key role in the fuel production process. The aforementioned agricultural biomass also includes the wheat biomass, which is represented in larger quantities in Croatia. Therefore, the aim of the paper is to show the influence of the amount of precipitation during cultivation on the energetic properties of wheat biomass. The research showed that a dry year affects the reduction of the undesirable ash component and reduction of heating values, while it has no significant effect on the energetic properties of wheat biomass.*

**Keywords:** proximate analysis, ultimate analysis, wheat straw, dry year.

### INTRODUCTION

The European Parliament has taken a decision to increase the share of renewable energy sources in the EU's final energy consumption to 45% by 2030, in line with the revision of the Renewable Energy Directive (REDII) — a goal also supported by the European Commission under the REPowerEU plan. By increasing the share of energy production from renewable energy sources, the requirements for energy production from biomass also increase.

Also, considering the continuous expansion of the world's population and the consequences of climate change, it is increasingly important to develop and apply methods of sustainable biomass production in order to enable the establishment of a growing and sustainable bioeconomy. Green technologies, including biofuels and bioproducts, are among the most effective strategies for reducing greenhouse gas emissions and global warming while meeting the energy needs of humanity (Antar et al. 2021). Biomass currently provides a certain amount of energy to many countries, however the accompanying technologies are not widely adopted, mainly due to low returns for biomass producers. Biomass is considered a

natural non-fossil organic material that contains intrinsic chemical energy with the potential to offset fossil fuel emissions, which represents a good alternative to fossil fuels (Rozzi et al., 2020). Alternative solid biofuel, produced from agricultural crops, is part of renewable energy sources with a green technological approach (Mansora et al., 2018).

The conversion of lignocellulosic materials such as cellulose, hemicellulose and lignin produces second generation or advanced biofuels (Hayes, 2009). Lignocellulosic biomass, in which also belong a wheat straw, although it has several positive properties, is associated with various disadvantages, such as structural heterogeneity, uneven physical properties, low energy density, hygroscopic nature and low bulk density (Medic et al., 2010). All these features create difficulties in transportation, handling, storage and conversion (Wannapeera et al., 2011).

Biomass conversion can deliver different types of products through different types of conversion processes including thermal, chemical and biochemical processes (Sengupta and Pike, 2012). Any processing is affected by the types of biomass and its physical and chemical characteristics. Information on biomass properties, including calorific value, ultimate/proximate properties, and structural components, has been applied in several literatures to simulate options for biomass conversion processes. According to the literature review, proximate and ultimate analysis have been studied in biomass conversion in terms of energy applications such as combustion, energy production and liquid fuel production (Lan et al., 2018).

Proximate analysis is performed to obtain information on moisture, bound carbon, volatile matter and ash content. Also, for the elemental composition, ultimate analysis is carried out to obtain the content of carbon, hydrogen, oxygen, nitrogen and inorganic species (Nimmanterdwong et al., 2021). However, variations in biomass composition are also visible in the same crops, but in different literature references, such as wheat straw in the research of Naik et al. (2010) has a much lower ash content than the research conducted by Raj et al. (2015). The aforementioned deviations in biomass composition are possible due to the influence of external conditions such as sunlight, precipitation, nutrients in the soil, etc. (Nimmanterdwong et al., 2021).

Improving biomass production does not only depend on the selection of crops that work well in the area where they will be produced and advanced agricultural practices, but must also be based on the prevailing environmental conditions. Climate change is currently unpredictable, and crops of interest will face increased levels and frequencies of abiotic and biotic stresses (Antar et al., 2021). Improving biomass production is complex because it can be affected by stress conditions, such as drought/flooding and heat/cold, even those associated with excessive fertilization (Lyu et al., 2020).

Sterile cereals, such as wheat, need larger amounts of water, especially in critical stages of growth and development (Gagro, 1997). The highest yields and the best quality of wheat grains are achieved in areas with 650-750 mm of precipitation per year, with a favorable distribution during the growing season (Kovačević and Rastija, 2014). Based on all of the above, the aim of the paper is to show the influence of precipitation on the energetic properties of wheat biomass.

## MATERIALS AND METHODS

The sowing of four varieties of wheat (Kraljica, Renata, Zrpanjka and El Nino) was carried out at the beginning of October, while the harvest/sampling was carried out in the middle of July 2021 and 2022 on the experimental field set up on the surface of the Osijek Agricultural Institute. The results of the amount of precipitation in the area of the city of Osijek were taken from the State Hydrometeorological Institute and are shown in table 1. During the 2021/2022 growing season, there were dry periods (January-April) during the formation of the mass of wheat compared to the year before.

**Table 1** Amount of precipitation in the area of Osijek during the 2020/2021 growing season and 2021/2022, (mm)

Month /Year	I	II	III	IV	V	VI	VII	VIII	IX	X	XI	XII
2020	-	-	-	-	-	-	-	-	-	86.5	18.0	61.4
2021	77.5	36.3	34.4	60.7	58.9	18.4	96.7	-	-	72.9	71.0	75.6
2022	7.5	28.7	6.4	35.0	66.0	77.2	19,2	-	-	-	-	-

After natural drying, biomass samples of 4 varieties of wheat were homogenized and crushed in a laboratory mill (IKA Analysentechnik GmbH, Germany). Such a mixture sample was analyzed at least three times to ensure reproducibility of the analyses.

Proximate analysis included the determination of moisture content (HRN EN 18134-2:2015), using a laboratory dryer (INKO, Croatia), ash (HRN EN ISO 18122:2015) using a muffle furnace (Nabertherm, USA), and the content of fixed carbon and volatile matter (EN 15148:2009) which were calculated by calculation.

The ultimate analysis included the determination of total carbon, hydrogen, nitrogen and sulfur which were determined simultaneously by the dry combustion method using a Vario Macro CHNS analyzer (Elementar Analysensysteme GmbH, Germany), according to the protocols for carbon, hydrogen and nitrogen (HRN EN ISO 16948:2015) and sulfur (HRN EN ISO 16994:2015) while the oxygen content was calculated from the difference.

Calorific values were determined using the EN 14918:2010 method using an adiabatic calorimeter (C200, IKA Analysentechnik GmbH, Heitersheim, Germany), while the lower calorific value was calculated by computational derivation.

## RESULTS AND DISCUSSION

Table 2 shows the results of the proximate analysis of wheat biomass, which include the proportion of moisture, ash, fixed carbon (C<sub>fix</sub>) and volatile matter.

Moisture content is the basic parameter that determines the net energy content of biomass and at the same time has a significant influence on the calorific value and the combustion process (Oberberger and Thek, 2004). In addition to difficult combustion, higher moisture content also causes increased emissions of harmful gases during the combustion process. A lower proportion of moisture in 2022 can be connected to a lower amount of rainfall at the

time of harvest. In addition to moisture content, ash content is also an important characteristic of solid biomass and refers to the non-combustible content of biomass and is an undesirable parameter in biomass due to its catalytic effect on thermal decomposition (Parmar, 2017). A significantly lower ash content was observed in the drier growing year (2021/2022) and amounted to 6.60%. The obtained proportions of moisture and ash are in accordance with the research of Sedmihradská et al. (2020).

**Table 2** Proximate analysis of wheat biomass

Year	Moisture (%)	Ash (%)	Cfix (%)	Volatile matter (%)
2021	11.17	9.31	9.43	72.19
2022	10.83	6.60	10.17	74.22

Fixed carbon is the amount of carbon bound in biomass and represents the mass content of residues after the release of volatile substances, excluding ash and moisture. A higher proportion of fixed carbon leads to higher biomass quality due to a positive effect on calorific value (McKendry, 2002). Also, as with the ash content, better characteristics based on the proportion of fixed carbon were observed in the drier growing year (2021/2022).

Volatile matter represents the gaseous phase that is created by the thermal decomposition of biomass and enables easier ignition of biomass (Caillat and Vakkilainen, 2013). A higher content of volatile substances reduces energy efficiency in the case of direct combustion of biomass (Magdziarzi et al., 2011). Vegetation year had no influence on the content of volatile matter, and the share was up to 74%, which is in accordance with the research conducted by Mitchell et al. (2020).

Table 3 shows the results of the ultimate analysis of wheat biomass, which include the proportion of nitrogen (N), carbon (C), sulfur (S), hydrogen (H) and oxygen (O).

**Table 3** Ultimate analysis of wheat biomass.

Year	N (%)	C (%)	S (%)	H (%)	O (%)
2021	0.52	44.06	0.04	6.12	49.26
2022	0.54	44.51	0.04	6.09	48.82

Based on the ultimate analysis, solid biofuels consist mainly of C, O and H. A higher content of C and H increases the calorific value, while a higher oxygen content decreases it (Obernberger and Thek, 2004). Sulfur oxides (SO<sub>x</sub>) are produced during combustion and contribute significantly to particle pollution and acid rain (Parmar, 2017). In addition to SO<sub>2</sub> emissions, sulfur contained in solid biofuel also plays a significant role in corrosion processes (Obernberger and Thek, 2004). Fuel-bound nitrogen accounts for the majority of NO<sub>x</sub> emissions produced by biomass combustion (Parmar, 2017). Increased nitrogen content in biomass usually results in increased NO<sub>x</sub> emissions during the combustion process



(Hartmann, 2012). Vegetation year had no influence on the ultimate properties of biomass, and the obtained values are in accordance with research by Mitchell et al. (2020).

Table 4 shows the calorific value of wheat biomass.

**Table 4** Calorific value of wheat biomass.

Year	HHV (MJ kg <sup>-1</sup> )	LHV (MJ kg <sup>-1</sup> )
2021	17.68	4:35 p.m
2022	16.54	15,21

The use of biomass as a fuel in thermal and electrical applications requires knowledge of its calorific value (Caillat and Vakkilainen, 2013). Lower heating value (LHV) is the appropriate value for the use of energy that is available for later use (Oberberger and Thek, 2004). The dry period had an impact on the calorific value of wheat biomass by reducing the calorific value. The obtained values are in accordance with the research of Satpathy et al. (2014).

## CONCLUSION

The researched biomass of wheat grown in different vegetation periods and different agroclimatic conditions has similar energy characteristics, and considering the obtained results of proximate and ultimate analysis and calorific value, it can be used in the production of solid fuel.

Positive impact of the dry period during the 2021/2022 growing season. it is visible in the reduction of the share of ash as an undesirable component during direct combustion, while the negative impact is manifested in the reduction of the calorific value.

## ACKNOWLEDGMENTS

This research was financed from the European Fund for Regional Development, within the program Competitiveness and Cohesion 2014 - 2020, within the framework of project no. KK.05.1.1.02.0016, "Production of food, biocomposites and biofuels from cereals in the circular bioeconomy".

## REFERENCES

- Antar, M., Lyu, D., Nazari, M., Shah, A., Zhou, X., Smith, DL (2021). Biomass for a sustainable bioeconomy: An overview of world biomass production and utilization. *Renewable and Sustainable Energy Reviews*, 139, 110691.
- Caillat, S., Vakkilainen, E. (2013). Large-scale biomass combustion plants: an overview. *Biomass combustion science, technology and engineering*, 189-224.
- Gagro, M. (1997): *Family Farming: Cereals and Pulses*. Croatian Agricultural Society, Zagreb.

- Hartmann, H. (2012). Solid biofuels, fuels and their characteristics. Technologie- und Förderzentrum im Kompe.
- Hayes, DJ (2009). An examination of biorefining processes, catalysts and challenges. *Catalysis today*, 145(1-2), 138-151.
- Kovačević, V., Rastija, M. (2014): Cereals. Textbook. Josip Juraj University Strossmayer in Osijek, Faculty of Agriculture in Osijek, Osijek.
- Lan, W., Chen, G., Zhu, X., Wang, X., Liu, C., Xu, B. (2018). Biomass gasification-gas turbine combustion for power generation system model based on ASPEN PLUS. *Science of the total environment*, 628, 1278-1286.
- Lyu, D., Backer, R., Subramanian, S., Smith, DL (2020). Phytomicrobiome coordination signals hold potential for climate change-resilient agriculture. *Frontiers in Plant Science*, 11, 634.
- Magdziarz, A., Wilk, M., Zajemska, M. (2011). Modeling of pollutant concentrations from the biomass combustion process. *Chemical and Process Engineering*, 32(4), 423-433.
- Mansor, AM, Lim, JS, Ani, FN, Hashim, H., Ho, WS (2018). Ultimate and proximate analysis of Malaysian pineapple biomass from MD2 cultivar for biofuel application. *Chemical Engineering Transactions*, 63, 127-132.
- McKendry, P. (2002). Energy production from biomass (part 2): conversion technologies. *Bioresource technology*, 83(1), 47-54.
- Medic, D., Darr, M., Potter, B., Shah, A. (2010). Effect of torrefaction process parameters on biomass feedstock upgrading. In 2010 Pittsburgh, Pennsylvania, June 20-June 23, 2010 (p. 1). American Society of Agricultural and Biological Engineers.
- Mitchell, EJS, Gudka, B., Whittaker, C., Shield, I., Price-Allison, A., Maxwell, D., Williams, A. (2020). The use of agricultural residues, wood briquettes and logs for small-scale domestic heating. *Fuel Processing Technology*, 210, 106552.
- Naik, S., Goud, VV, Rout, PK, Jacobson, K., Dalai, AK (2010). Characterization of Canadian biomass for alternative renewable biofuel. *Renewable energy*, 35(8), 1624-1631.
- Nimmanterdwong, P., Chalermisinsuwan, B., Piumsomboon, P. (2021). Prediction of lignocellulosic biomass structural components from ultimate/proximate analysis. *Energy*, 222, 119945.
- Obemberger, I., & Thek, G. (2004). Physical characterization and chemical composition of densified biomass fuels with regard to their combustion behavior. *Biomass and bioenergy*, 27(6), 653-669.
- Parmar, K. (2017). Biomass-An overview on composition characteristics and properties. *IRA-International journal of applied sciences*, 7(1), 42-51.
- Raj, T., Kapoor, M., Gaur, R., Christopher, J., Lamba, B., Tuli, DK, Kumar, R. (2015). Physical and chemical characterization of various Indian agricultural residues for biofuels production. *Energy & Fuels*, 29(5), 3111-3118.
- Rozzi, E., Minuto, FD, Lanzini, A., Leone, P. (2020). Green synthetic fuels: renewable routes for the conversion of non-fossil feedstocks into gaseous fuels and their end uses. *Energies*, 13(2), 420.
- Satpathy, SK, Tabil, LG, Meda, V., Naik, SN, Prasad, R. (2014). Torrefaction of wheat and barley straw after microwave heating. *Fuel*, 124, 269-278.
- Sedmíhradská, A., Pohořelý, M., Jevič, P., Skoblia, S., Beňo, Z., Farták, J., Hartman, M. (2020). Pyrolysis of wheat and barley straw. *Research in Agricultural Engineering*, 66(1), 8-17.
- Sengupta, D., Pike, RW (2012). Chemicals from biomass: integrating bioprocesses into chemical production complexes for sustainable development. CRC Press.
- Wannapeera, J., Fungtammasan, B., Worasuwannarak, N. (2011). Effects of temperature and holding time during torrefaction on the pyrolysis behaviors of woody biomass. *Journal of analytical and applied pyrolysis*, 92(1), 99-105.



## LIGNOCELLULOSIC COMPOSITION AND HEATING VALUE OF FOREST AND AGRICULTURAL BIOMASS: A REVIEW

Božidar MATIN<sup>1</sup>, Tajana KRIČKA<sup>2</sup>, Alen ĐUROVIĆ<sup>1</sup>, Mateja GRUBOR<sup>3</sup>, Ana MATIN<sup>2\*</sup>, Alan ANTONOVIĆ<sup>1</sup>

\*E-mail of corresponding author: amatin@agr.hr

<sup>1</sup>University of Zagreb Faculty of Forestry and Wood Technology, Department of Wood Technology, Svetošimunska cesta 23, 10000 Zagreb, Croatia

<sup>2</sup>University of Zagreb Faculty of Agriculture, Department of Agricultural Technology, Storage and Transport, Svetošimunska cesta 25, 10000 Zagreb, Croatia

<sup>3</sup>University of Zagreb Faculty of Agriculture, Department of Agricultural Engineering, Svetošimunska cesta 25, 10000 Zagreb, Croatia

### ABSTRACT

*Biomass is available in large quantities and is relatively inexpensive. It includes residues from agricultural production, forestry, and wood processing industries. The renewable energy contained in biomass can help reduce greenhouse gas emissions and dependence on fossil fuels, and is a much more environmentally friendly solution as an alternative energy source. The amount of energy that certain biomass can produce depends on the composition of the lignocellulose (lignin, cellulose, and hemicellulose), which directly affects the heating value of the biomass. The calorific value of cellulose and hemicellulose is about 18.60 MJ kg<sup>-1</sup>, and that of lignin is 22.2 to 28.5 MJ kg<sup>-1</sup>, so it is desirable to have the highest possible lignin content in the biomass. The objective of this work was to determine the lignocellulosic composition of forest and agricultural biomass and to determine if this composition affects the heating value of the biomass.*

**Keywords:** lignocellulosic composition, biomass, heating value

### INTRODUCTION

An important component of the economy and society is the use of resources such as biomass, sources of organic material in the form of plants, trees, organic waste, and algae in which solar energy is stored in chemical bonds. By breaking the bonds between molecules,

either through combustion, decomposition, or digestion, biomass releases stored energy (McKendry, 2002). In 2018, fossil fuels accounted for 81% (petroleum 31%, natural gas 23%, coal 27%) of primary energy production, while renewable sources accounted for 14% (67.2% bioenergy) (Song et al., 2018). Fossil fuel burning releases huge amounts of CO<sub>2</sub> into the atmosphere and depletes the non-renewable source, while biomass burning also releases new amounts of CO<sub>2</sub> into the atmosphere, but plant replanting ensures absorption through a new growth cycle (McKendry, 2002). The growth potential of biomass as a renewable energy source (RES) depends mainly on the available quantities from forestry, agricultural, or industrial production on a global scale (Li et al., 2017). However, there may be a problem that, as in the case of agricultural biomass, there are no systematic data on the available amount, but this amount is determined by empirical models by subtracting it from the total agricultural production. Differences caused by agroclimatic conditions, varietal differences, or agrotechnical measures (fertilisation, irrigation) are not taken into account, and there is also a lack of data on the way agricultural residues are used or collected (Camia et al., 2018).

Nie et al. (2022) divided biomass potential into several categories: theoretical potential, which indicates the total amount of biomass that can be produced within biological and physical limits; economic potential, which represents the amount that can be produced economically; technical potential, which indicates the amount that can be produced with available technologies; while environmental potential represents the amount that can be produced while taking into account environmental protection requirements such as biodiversity and soil conservation (EUBIA, 2021). The advantage of biomass as an energy source is that biomass materials can be burned directly in plants to generate electricity (Kumar et al., 2015) or in incinerators to generate heat in homes or industry (Perea-Moreno et al., 2018). The use of biomass itself has been the subject of research for many years, while recently much attention has been paid to the development of new generations of fuels. It is clear that the first two generations of biofuels cannot satisfy all needs, so it is necessary to focus efforts on even greater development of third and fourth generation biofuels (Osman et al., 2021). The use of biomass as a feedstock for energy production has become increasingly important in the last decade, with a focus on lignocellulosic biomass from agriculture and forestry (Arteaga-Perez et al., 2015). Unfortunately, large amounts of lignocellulosic biomass are still being burned, which could potentially be converted into various value-added products such as biofuels and chemicals, or used as cheap energy sources for enzyme production and microbial fermentation (Anwar et al., 2014).

Converting biomass to RES generally has two goals: electricity/heat energy from forest biomass for the utility/industrial sector and biodiesel/bioethanol from agricultural biomass for the transportation sector (Guo et al., 2010). Renewable energy derived from biomass feedstock is referred to as biofuel and is divided into primary and secondary. Primary biofuels include firewood, wood chips and pellets, and crop residues, which are mainly used in heating systems (Rodionova et al., 2017). Secondary biofuels are produced as derivatives of primary fuels in the form of solids (charcoal), liquids (bioethanol, biodiesel), and gases (hydrogen, biogas). Liquid and gaseous biofuels can also be produced by processing biomass, and they can be used as an energy source in transportation and various industrial processes (Doshi et al., 2016). Secondary biofuels are classified into four generations, the first and second of

which are based on primary biomass sources (Azad et al., 2015), the third on microalgae (Chew et al., 2018), and the fourth on genetically modified microalgae (Zhu et al. et al., 2017).

Lignocellulosic biomass is a valuable renewable resource that can be used directly or indirectly through physical, chemical, enzymatic, or microbial processes to produce bioproducts that can later be used in the medical, food, health, energy, and chemical industries (Rodriguez and Espinosa, 2021). For the production of fuels and chemicals from biomass to be efficient, the physicochemical properties of lignocellulosic biomass and the methods for analytical characterization of these properties must be known, as they can significantly affect the performance of the conversion process and the feedstock and transportation supply chain network (Cai et al., 2017). The chemical composition of biomass, whether lignocellulosic or herbaceous, is defined by several major components, namely polymers: cellulose, lignin, and hemicellulose, and extractive materials (Williams et al., 2017) that provide structure and strength to plants (Sanderson, 2011).

Cellulose consists of high molecular weight glucose polymers linked by  $\beta$ -(1 $\rightarrow$ 4)-glycosidic bonds to form fiber bundles, which give it strength and make it resistant to hydrolysis; at the same time, it is the most abundant biopolymer on Earth (Lange, 2007). Hemicellulose is a heterogeneous polymer belonging to the group of polysaccharides, whose basic structure consists of a series of interconnected xylose molecules as well as other sugars such as mannose, galactose, and arabinose, and its function is to form links between cellulose and lignin. Due to branching, hemicellulose has an amorphous structure and is much more susceptible to hydrolysis or dissolution in alkali (Alonso et al., 2013; Williams et al., 2017). Cellulose and hemicellulose, together with lignin, account for more than 90% of lignocellulosic biomass and 80% of herbaceous biomass. Lignin is a three-dimensional polymer of propylphenol that binds hemicellulose and cellulose in the cell wall of plants (Williams et al., 2017) and provides plants with a hydrophobic surface that allows them to transport water to high altitudes and contributes to mechanical strength (Koch et al., 2004), while its physicochemical properties serve as protection against attack by pathogens and pests (Vance et al., 1980; Bhuiyan et al., 2009). Lignin is a major problem in the production of liquid biofuels, so biomass with a higher lignin content is more suitable for conversion to solid fuels, because as the lignin content increases, the calorific value of lignocellulosic fuels also increases (Li et al., 2003; Chen and Dixon, 2007). For example, Demirbas (2017) reports the heating value of lignin as 22.2 to 28.5 MJ kg<sup>-1</sup>, while cellulose and hemicellulose have a slightly lower HHV of 18.6 MJ kg<sup>-1</sup> (Demirbas, 2001). The objective of this work is to compare the lignocellulosic composition of certain types of forest and agricultural biomass and to determine how this composition, especially the lignin content, affects their calorific value.

## **LIGNOCELLULOSIC COMPOSITION OF FOREST AND AGRICULTURAL BIOMASS**

Cellulose, lignin, and hemicellulose are not uniformly distributed in the cell wall, so the amount and structure of these components depend on the type and maturity of the plant cell wall (Barakat et al., 2013). Lignocellulosic biomass generally contains 35-50% cellulose, 10-25% lignin and 20-35% hemicellulose, while oils, proteins, and ash make up the remainder

(Saha, 2005). Forest biomass contains on average 50-55% cellulose, 20-30% lignin, and 15-25% hemicellulose (Antonović, 2004). Table 1 shows the average proportions of lignocellulosic composition of certain types of forest biomass.

**Table 1** Lignocellulosic composition of forest biomass (%)

<b>Biomass</b>	<b>Cellulose</b>	<b>Lignin</b>	<b>Hemicellulose</b>	<b>Source:</b>
	43.2	35.4	21.9	Yu et. Al. (2017)
Oak	40.4	24.1	35.9	Isikgor and Becer (2015)
	39.3	24.4	26.7	Ulusal et. al. (2021)
	42.0	22.0	35.0	Tribot et. al. (2019)
Beech	46.3	21.9	31.9	Demirbas (2001)
	43.8	29.05	24.8	Antonović et. al. (2007)
	49.0	20.0	24.0	Di Blasi et. al. (2010)
Poplar	49.9	19.3	25.4	Bohaček et. al. (2020)
	48.9	27.2	22.9	Rego et. al. (2019)
	45.5	27.9	22.9	Isikgor et. al. (2015)
Spruce	47.1	31.6	21.3	Demirbas (2001)
	43.0	27.6	29.4	Demirbaş (2005)
	45.6	26.8	24.0	Yu et. al. (2017)
Pine	46.9	27.3	20.3	Taherzadeh et. al. 1997)
	40.0-50.0	16.0-33.0	25.0-35.0	Mohan et. al. (2006)
	46.0-50.0	21.0-29.0	19.0-22.0	Gellerstedt and Henriksson (2008)
Soft wood	46.0-50.0	21.0-29.0	19.0-22.0	Gellerstedt and Henriksson (2008)
Hard wood	43.0-47.0	16.0-24.0	25.0-35.0	Chong et. al. (2021)

Agricultural biomass contains varying proportions of cellulose, lignin, and hemicellulose, as well as a small proportion of extractive materials. The relative proportion of cellulose and lignin is one of the most important factors in determining the suitability of a particular agricultural crop for energy production. On average, it contains 40-50% cellulose, 10-25% lignin, and 20-30% hemicellulose (Iqbal et al., 2011; Kumar et al., 2009; Malherbe and Cloete, 2002). The average percentages of lignocellulosic composition of each agricultural and energy crop are shown in Table 2.

**Table 2** Lignocellulosic composition of agricultural biomass (%)

<b>Biomass</b>	<b>Cellulose</b>	<b>Lignin</b>	<b>Hemicellulose</b>	<b>Source:</b>
Wheat	30.0	15.0	50.0	Chong et. al. (2021)
	32.2	12.8	47.9	Matin et. al. (2019)
	33.8	21.0	45.2	Demirbas (2001)
Barley	37.5	15.8	37.1	Sun et al. (2011)
	40.0	15.0	30.0	Saini et. al. (2015)
	37.5	26.1	25.3	Monlau et. al. 2013)
Corn	40.5	19.8	20.7	Aboagye et. al. (2017)
	51.5	17.6	30.9	Demirbas (2001)
	42.2	24.6	25.7	Grubor et. al. (2021)
Sunflower	31.0	29.2	15.6	Monlau et. al. (2013)
	38.7	24.9	29.8	Antonović et. al. (2017)
	32.0	22.0	18.0	Antonopoulou et. al. (2015)
Switchgrass	35.0-40.0	15.0-20.0	25.0-30.0	Cai et. al. (2017)
	39.3	21.7	31.2	Kim et. al. (2018)
	40.3	20.1	30.5	Doczekalska et. al. (2020)
Miscanthus	51.1	30.1	15.7	Antonović i sur. (2016)
	53.1	29.0	13.5	Grubor et. al. (2021)
	49.3	29.3	19.3	Bilandžija et. al. (2017)

## HEATING VALUE OF FOREST AND AGRICULTURAL BIOMASS

The heating value of biomass indicates the amount of energy released from a given amount of biomass that burns completely in the presence of oxygen (Abdullah et al., 2020). It is divided into upper heating value (HHV) and lower heating value (LHV). HHV indicates the amount of energy released when a mass of solid fuel is burned under certain conditions with condensation of the water produced during combustion, while LHV indicates the amount of energy produced during combustion under constant volume conditions where all the water remains as a reaction product in the form of water vapor. Lignocellulosic biomass, which has a higher lignin content, is more suitable for conversion by pressing into solid biofuels that are later used by direct combustion to generate electricity or thermal energy, and research has also

shown that there is a significant relationship between the HHV and LHV of biomass-derived fuels and the lignin content (Demirbas, 2001.; Demirbas, 2004). Forest biomass has a slightly higher calorific value than herbaceous biomass, so the HHV of forest biomass ranges from 18.5 to 22.5 MJ kg<sup>-1</sup> (Cai et al., 2017), while freshly harvested wood can have only 5.9 MJ kg<sup>-1</sup> (Lyons et al., 1985). Table 3 shows the heating value of certain types of forest biomass.

**Table 3** Heating values of forest biomass (MJ kg<sup>-1</sup>).

<b>Biomass</b>	<b>HHV</b>	<b>LHV</b>	<b>Source:</b>
Oak	18.8	17.4	Dyjakon and Noszczyk, (2022)
	19.2 <sup>1</sup>	18.2 <sup>2</sup>	Núñez-Retana et. al. (2019) <sup>1</sup> , Krička et. al. (2012) <sup>2</sup>
	18.7	15.4	Telmo and Lousada (2011)
Beech	19.2	13.6	Kamperidou et. al. (2018)
	19.1	15.8	Telmo and Lousada (2011)
	19.4	18.3	Vusić et. al. (2021)
Poplar	19.2	18.0	Librenti et. al. (2010)
	19.5	18.1	Fernandez et. al. (2006)
	18.8	16.1	Telmo and Lousada (2011)
Spruce	19.8	18.5	Kačik et. al. (2022)
	18.6	17.2	Günther et. al. (2012)
	18.1	17.8	Spirchez et. al. (2021)
Poplar	20.2	16.9	Telmo and Lousada (2011)
	21.6	19.8	Viana et. al. (2018)
	20.8	19.5	Kačik et. al. (2022)
Pine	18.4-20.5	15.6-16.9	Telmo and Lousada (2011)
	17.6-20.8	14.4-17.9	Telmo and Lousada (2011)

Most agricultural biomasses have a calorific value in the range of 15.5 to 19.5 MJ/kg<sup>-1</sup>, while for comparison, the calorific value of coal ranges from 17.0 to 30.0 MJ/kg<sup>-1</sup> (Cai et al., 2017). The average values of HHV and LHV of each agricultural and energy crop are shown in Table 4.



**Table 4** Heating values of agricultural biomass (MJ kg<sup>-1</sup>)

<b>Biomass</b>	<b>HHV</b>	<b>LHV</b>	<b>Source:</b>
Wheat	16.7	15.4	Matin et. al. (2019)
	18.9	15.0	Chong et. al. (2021)
	18.3	13.8	Miranda et. al. (2015)
Barley	17.4	15.1	Miranda et. al. (2015)
	17.5	16.3	Jenkins and Ebeling (1985)
	15.4	14.0	Noori (2019)
Corn	16.3	14.9	Grubor et. al. (2018)
	17.6	16.5	Jenkins and Ebeling (1985)
	15.7-17.7	14.3-16.3	Olugbemide et. al. (2021)
Sunflower	16.2	14.3	Duca et. al. (2015)
	17.8	16.5	Perea et. al. (2018)
	18.6	17.2	Unal and Alibas (2006)
Switchgrass	19.1	16.8	Doczekalska et. al. (2020)
	18.5	17.0	Librenti et. al. (2010)
	19.7	18.2	Kumar and Ghosh (2018)
Miscanthus	19.1	17.8	Jurišić et. al. (2014)
	18.5	17.2	Librenti et. al. (2010)
	18.2	17.3	Bilandžija et al. (2017)

## CONCLUSION

Forest and agricultural biomass are one of the most important sources of raw materials that can be efficiently converted into usable bioenergy without harmful effects on the environment and climate. Biomass consists of biopolymers made up of different types of cells whose walls are composed of cellulose, lignin, and hemicellulose. It has already been mentioned that cellulose and hemicellulose have a lower calorific value than lignin, which is due to a higher degree of oxidation. The study shows that the lignocellulose composition of both forest (hardwood and softwood) and agricultural species is within the average range for each biomass. For forest biomass, it is clear that conifers (softwood) have a lower percentage of hemicellulose and a higher percentage of lignin than hardwood (hardwood), which is why

their heating value is higher. Agricultural biomass has a slightly lower proportion of lignin than forest biomass, resulting in a lower calorific value. The exception is agricultural energy crops, whose lignin content is the same as that of forest biomass, so the calorific value is the same.

## ACKNOWLEDGEMENT

This research was funded by the European Regional Development Fund, under the Operational program competitiveness and cohesion 2014–2022, project no. KK 01.2.1.02.0286, “Development of innovative pellets from forest and/or agricultural biomass—INOPELET”

## REFERENCES

- Abdullah, A., Ahmed, A., Akhter, P., Razzaq, A., Zafar, M., Hussain, M., Shahzad, N., Majeed, K., Khurram, S., Bakar, M.S.A., Park, Y.K. (2020). Bioenergy potential and thermochemical characterization of lignocellulosic biomass residues available in Pakistan. *Korean Journal of Chemical Engineering* 37(11), 1899-1906.
- Aboagye, D., Banadda, N., Kambugu, R., Seay, J., Kiggundu, N., Zziwa, A., Kabenge, I. (2017). Glucose recovery from different corn stover fractions using dilute acid and alkaline pretreatment techniques. *Journal of Ecology and Environment* 41(1), 1-11.
- Alonso, D.M., Wettstein, S.G., Mellmer, M.A., Gurbuz, E.I., Dumesic, J.A. (2013). Integrated conversion of hemicellulose and cellulose from lignocellulosic biomass. *Energ. Environ. Sci.* 6(1), 76-80.
- Antonopoulou G., Dimitrellos G., Beobide A.S., Vayenas D., Lyberatos G. (2015). Chemical pretreatment of sunflower straw biomass: the effect on chemical composition and structural changes. *Waste Biomass Valori.* 6(1), 733–746.
- Antonović, A. (2004). Spektrofotometrijska analiza lignina bukovine. *Magistarski rad. Sveučilište u Zagrebu, Šumarski fakultet* 1-214.
- Antonović, A., Jambrečković, V., Pervan, S., Ištvančić, J., Moro, M., Zule, J. (2007). Utjecaj lokaliteta uzorkovanja na grupni kemijski sastav bijeli bukovine (*Fagus sylvatica* L.). *Drvena industrija* 58(3), 119-125.
- Antonović, A., Krička, T., Matin, A., Voća, N., Jurišić, V., Bilandžija, N., Grubor, M., Stanešić, J. (2017). Lignocellulosic composition of some important oilseeds and grains Biomass in the Republic of Croatia. *52nd Croatian and 12th international symposium on agriculture* 623-627.
- Anwar, Z., Gulfranz, M., Irshad, M. (2014). Agro-industrial lignocellulosic biomass a key to unlock the future bio-energy: a brief review. *Journal of radiation research and applied sciences* 7(2), 163-173.
- Arteaga-Pérez, L.E., Segura, C., Espinoza, D., Radovic, L.R., Jiménez, R. (2015). Torrefaction of *Pinus radiata* and *Eucalyptus globulus*: A combined experimental and modeling approach to process synthesis. *Energy Sustain. Dev.* 29, 13–23.
- Azad, A.K., Rasul, M., Khan, M.M.K., Sharma, S.C., Hazrat, M. (2015). Prospect of biofuels as an alternative transport fuel in Australia. *Renew. Sust. Energy Rev.* 43, 331-351
- Barakat, A., de Vries, H., Rouau, X. (2013). Dry fractionation process as an important step in current and future lignocellulose biorefineries: a review. *Bioresource technology* 134, 362-373.
- Bhuiyan, N. H., Selvaraj, G., Wei, Y., King, J. (2009). Role of lignification in plant defense. *Plant signaling & behavior*, 4(2) 158–159.

- Bilandžija, N., Jurišić, V., Voća, N., Leto, J., Matin, A., Grubor, M., Krička, T. (2017). Energy valorization of *Miscanthus x giganteus* biomass: a case study in Croatia. *Journal on Processing and Energy in Agriculture* 21(1), 32-36.
- Boháček, Š., Pažitný, A., Halaj, M., Balberčák, J., Kuňa, V. (2020). Freeze-thaw pretreatment of poplar sapwood dust. *Wood Research* 65(6), 905-916.
- Cai, J., He, Y., Yu, X., Banks, S.W., Yang, Y., Zhang, X., Yu, Y., Liu, R., Bridgwater, A.V., (2017). Review of physicochemical properties and analytical characterization of lignocellulosic biomass. *Renewable and sustainable energy reviews* 76, 309-322.
- Camia, A., Robert, N., Jonsson, R., Pilli, R., Garcia, S., Lopez-Lozano, R., Velde, M., Ronzon, T., Gurria, P., M'Barek, R., Tomosiunas, S., Fiore, G., Araujo, R., Hoepffner, N., Marelli, L., Giuntoli, J. (2018). Biomass production, supply, uses and flows in the European Union. First results from an integrated assessment.
- Chen, F., Dixon, R.A. (2007). Lignin modification improves fermentable sugar yields for biofuel production. *Nat Biotechnol* 25, 759–761
- Chew, K.W., Chia, S.R., Show, P.L., Ling, T.C., Arya, S.S., Chang, J.S. (2018). Food waste compost as an organic nutrient source for the cultivation of *Chlorella vulgaris*. *Bioresour Technol.* 267, 356- 362.
- Chong, T.Y., Law, M.C., Chan, Y.S. (2021). The Potentials of Corn Waste Lignocellulosic Fibre as an Improved Reinforced Bioplastic Composites. *J Polym Environ* 29, 363–381.
- Demirbas, A. (2017). Higher heating values of lignin types from wood and non-wood lignocellulosic biomasses, *Energy Sources, Part A: Recovery, Utilization, and Environmental Effects* 39(6), 592-598.
- Demirbaş, A. (2001). Relationships between lignin contents and heating values of biomass. *Energy conversion and management*, 42(2), 183-188.
- Demirbaş, A. (2005). Thermochemical conversion of biomass to liquid products in the aqueous medium. – *Energy Sources* 27: 1235-1243.
- Demirbaş, A. (2004). Combustion Characteristics of Different Biomass Fuels. *Progress in Energy and Combustion Science.* 30. 219-230.
- Di Blasi, C., Branca, C., Galgano, A. (2010). Biomass screening for the production of furfural via thermal decomposition. – *Industrial & Engineering Chemistry Research* 49:2658-2671.
- Doczekalska, B., Bartkowiak, M., Waliszewska, B., Orszulak, G., Cerazy-Waliszewska, J., Pniewski, T. (2020). Characterization of Chemically Activated Carbons Prepared from *Miscanthus* and *Switchgrass* Biomass. *Materials.* 13(7):1654.
- Doshi, A., Pascoe, S., Coglean, L., Rainey, T.J. (2016). Economic and policy issues in the production of algae-based biofuels: A review. *Renew. Sustainable Energy Rev.* 64, 329-337.
- Duca, D., Toscano, G., Riva, G., Mengarelli, C., Rossini, G., Pizzi, A., Del Gatto, A., Foppa Pedretti, E. (2015). Quality of residues of the biodiesel chain in the energy field. *Industrial Crops and Products.* 75, 91-97.
- Fernandez Llorente M.J., Murillo Laplaza J.M., Escalada Cuadrado R., Carrasco Garcia J.E. (2006). Ash behaviour of lignocellulosic biomass in bubbling fluidised bed combustion, *Fuel* 85 1157-1165.
- Gellerstedt, G., Henriksson, G. (2008). Lignins: major sources, structure and properties. Monomers, polymers and composites from renewable resources, 201-224.
- Grubor, M., Krička, T., Bilandžija, N., Jurišić, V., Voća, N., Antonović, A., Matin, A. (2018). *Kukuruzovina kao energent za proizvodnju krutog goriva.* *Proceedings SA* 2018. 275-279.
- Grubor, M., Matin, A., Bilandžija, N., Bischof, S., Jurišić, V., Kontek, M., Krička, T. (2021). *Miscanthus* and maize stalk as source for green energy production. *Proceedings of the 48th International Symposium Actual Tasks on Agricultural Engineering.* 455-461.

- Günther, B., Gebauer, K., Barkowski, R., Rosenthal, M., Bues, C.T. (2012). Calorific value of selected wood species and wood products. *European Journal of Wood and Wood Products*. 70, 755-757.
- Guo, Z., Sun, C., Grebner, D. (2010). Utilization of Forest Derived Biomass for Energy Production in the U.S.A.: Status, Challenges, and Public Policies. *International Forestry Review*. 9(3), 748-758.  
<https://www.eubia.org/cms/wiki-biomass/bioenergy-production-potential/> (21.11.2022.)
- Iqbal, H.M.N., Ahmed, I., Zia, M.A., Irfan, M. (2011). Purification and characterization of the kinetic parameters of cellulase produced from wheat straw by *Trichoderma viride* under SSF and its detergent compatibility. *Advances in Bioscience and Biotechnolog.* 2(3), 149-156.
- Isikgor, F.H., Becer, C.R. (2015). Lignocellulosic biomass: a sustainable platform for the production of bio-based chemicals and polymers. *Polymer Chemistry*. 6(25), 4497-4559.
- Jenkins, B.M., Ebeling, J.M. (1985). Thermochemical properties of biomass fuels. *California Agriculture*, 39, 14-16.
- Jurišić, V., Bilandžija, N., Krička, T., Leto, J., Matin, A., Kuže, I. (2014). Fuel properties' comparison of allochthonous *Miscanthus x giganteus* and autochthonous *Arundo donax* L.: a study case in Croatia. *Agriculturae Conspectus Scientificus*. 79(1), 7-11.
- Kačik, F., Đurković, J., Kačiková, D. (2012). Chemical profiles of wood components of poplar clones for their energy utilization. *Energies*. 5(12), 5243-5256.
- Kamperidou, V., Lykidis, C., Barmpoutis, P. (2018). Utilization of wood and bark of fast-growing hardwood species in energy production. *Journal of Forest Science*. 64, 164-170.
- Kim, P., Hamilton, C., Elder, T., Labbe, N. (2018). Effect of non-structural organics and inorganics constituents of switchgrass during pyrolysis. *Frontiers in Energy Research*. 6, 96.
- Koch, G.W., Sillett, S.C., Jennings, G.M., Davis S.D. (2004). The limits to tree height. *Nat Biotechnol*. 428: 851–854.
- Krička, T., Bilandžija, N., Jurišić, V., Voća, N., Matin, A. (2012). Energy analysis of main residual biomass in Croatia. *African journal of agricultural research*. 7 (48), 6383-6388
- Kumar, A., Kumar, N., Baredar, P., Shukla, A.A. (2015). Review on biomass energy resources, potential, conversion and policy in India. *Renew. Sustain. Energy Rev.* 45, 530–539.
- Kumar, P., Barrett, D.M., Delwiche, M.J., Stroeve, P. (2009). Methods for pretreatment of lignocellulosic biomass for efficient hydrolysis and biofuel production. *Industrial & Engineering Chemistry Research*. 48, 3713-3729.
- Kumar, S., Ghosh, P. (2018). Sustainable bio-energy potential of perennial energy grass from reclaimed coalmine spoil (marginal sites) of India, *Renewable Energy*. 123, 475-485
- Lange, J.P. (2007). Lignocellulose conversion: an introduction to chemistry, process and economics. *Biofuels, Bioprod. Bioref.* 1: 39-48.
- Li, L., Zhou, Y., Cheng, X., Sun, J., Marita, J., Ralph, J., Chiang, V. (2003). Combinatorial modification of multiple lignin traits in trees through multigene cotransformation. *Proc Natl Acad Sci USA*. 100: 4939–4944
- Li, Y., Rezgui, Y., Zhu, H. (2017). District heating and cooling optimization and enhancement—Towards integration of renewables, storage and smart grid. *Renew. Sustain. Energy Rev.* 72, 281–294.
- Librenti, E., Ceotto, E., Di Candilo, M. (2010). Biomass characteristics and energy contents of dedicated lignocellulosic crops. In *Third International Symposium of Energy from Biomass and Waste*.
- Lyons, G.J., Lunny, F., Pollock, H P. (1985). A procedure for estimating the value of forest fuels, *Biomass*, Volume 8, Issue 4, Pages 283-300.
- Malherbe, S., Cloete, T.E. (2002). Lignocellulose biodegradation: fundamentals and applications. *Reviews in Environmental Science and Biotechnology*, 1, 105-114

- Matin, A., Krička, T., Grubor, M., Leto, J., Bilandžija, N., Voća, N., Jurišić, V., Zmaić, K., Kiš, D., Kopilović, I. (2019). Iskoristivost posliježetvenih ostataka za proizvodnju zelene energije. Osijek, Sveučilište Josipa Jurja Strossmayera u Osijeku Fakultet agrobiotehničkih znanosti Osijek.
- McKendry, P. Energy production from biomass (part 1): overview of biomass, *Bioresource Technology*, Volume 83, Issue 1, 2002, Pages 37-46, ISSN 0960-8524.
- Miranda, T., Montero, I., Sepúlveda, F., Arranz, J., Rojas, C., Nogales, S.A. (2015). Review of pellets from different sources. *Materials*; 8:1413–1427.
- Mohan, D., Pittman Jr, C.U., Steele, P.H. (2006). Pyrolysis of wood/biomass for bio-oil: a critical review. *Energy & fuels*, 20(3), 848-889.
- Monlau, F., Barakat, A., Trably, E., Dumas, C., Steyer, J.P., Carrère, H. (2013). Lignocellulosic materials into biohydrogen and biomethane: Impact of structural features and pretreatment. *Crit. Rev. Environ. Sci. Technol.* 43, 260–322.
- Nie, Y., Li, J., Wang, C., Huang, G., Fu, J., Chang, S., Cai, W. (2022). A fine-resolution estimation of the biomass resource potential across China from 2020 to 2100. *Resources, Conservation and Recycling*, 176, 105944.
- Noori, A.G. (2019). Assessment of Crop Residues Energy Potential and Efficient Usage in the South-western Zone of Afghanistan. *European Journal of Engineering and Technology Research*, 4(10), 138-142.
- Núñez-Retana, V.D., Wehenkel, C., Vega-Nieva, D.J., García-Quezada, J., Carrillo-Parra, A. (2019). The bioenergetic potential of four oak species from northeastern Mexico. *Forests*, 10(10), 869.
- Olugbemide, A.D., Oberlinter, A., Novak, U., Likozar, B. (2021). Lignocellulosic corn stover biomass pre-treatment by deep eutectic solvents (Des) for biomethane production process by bioresource anaerobic digestion. *Sustainability*, 13(19), 10504.
- Osman, A.I., Qasim, U., Jamil, F., Ala'a, H., Jrai, A.A., Al-Riyami, M., Rooney, D.W. (2021). Bioethanol and biodiesel: Bibliometric mapping, policies and future needs. *Renewable and Sustainable Energy Reviews*, 152, 111677.
- Perea-Moreno, M.A., Manzano-Agugliaro, F., Perea-Moreno, A.J. (2018). Sustainable Energy Based on Sunflower Seed Husk Boiler for Residential Buildings. *Sustainability*. 10. 3407.
- Rego, F., Dias, A.P.S., Casquilho, M., Rosa, F.C., Rodrigues, A. (2019). Fast determination of lignocellulosic composition of poplar biomass by thermogravimetry. *Biomass and bioenergy*, 122, 375-380.
- Rodionova, M., Poudyal, R., Tiwari, I., Voloshin, R., Zharmuk-Hamedov, S., Nam, H., Zayadan, B., Bruce, B., Hou, H., Al-lakhverdiev, S. (2017). Biofuel production: challenges and opportunities. *Int. J. Hydrog. Energy*. 42(12), 8450-8461
- Rodríguez, A., Espinosa, E. (2021). Special Issue “Lignocellulosic Biomass”. *Molecules*, 26(5), 1483.
- Saha, B. C., *Enzymes as Biocatalysts for Conversion of Lignocellulosic Biomass to Fermentable Sugars*, in *Handbook of Industrial Biocatalysis*, ed. C. T. Hou, CRC Press, 2005.
- Saini J.K., Saini R., Tewari L. (2015). Lignocellulosic agriculture wastes as biomass feedstocks for second-generation bioethanol production: concepts and recent developments. *3 Biotech*. 5:337–353.
- Sanderson, K. (2011). Lignocellulose: A chewy problem. *Nature* 474, S12–S14.
- Song, Q., Wang, Z., Li, J., Duan, H., Yu, D., Liu, G. (2018). Comparative life cycle GHG emissions from local electricity generation using heavy oil, natural gas, and MSW incineration in Macau. *Renewable and Sustainable Energy Reviews*, 81, 2450-2459.
- Spirchez, C., Lunguleasa, A., Ionescu, C.Ş., Avram, A. (2021). Calorific properties of the wood biomass from some softwood species. In *MATEC Web of Conferences* (Vol. 343). EDP Sciences.
- Sun, X.F., Jing, Z., Fowler, P., Wu, Y., Rajaratnam, M. (2011). Structural characterization and isolation of lignin and hemicelluloses from barley straw. *Industrial Crops and Products*, 33(3), 588-598.

- Taherzadeh, M.J., Eklund, R., Gustafsson, L., Niklasson, C., Lidén, G. (1977). Characterization and fermentation of dilute-acid hydrolyzates from wood. – *Industrial & Engineering Chemistry Research* 36: 4659-4665.
- Telmo, C., Louzada, J. (2011). Heating values of wood pellets from different species. *Biomass and Bioenergy*. 35. 2634-2939.
- Tribot, A., Amer, G., Alio, M.A., de Baynast, H., Delattre, C., Pons, A., Dussap, C.G. (2019). Wood-lignin: Supply, extraction processes and use as bio-based material. *European Polymer Journal*. 112, 228-240.
- Ulusal, A., Apaydın Varol, E., Bruckman, V J., Uzun, B.B. (2021). Opportunity for sustainable biomass valorization to produce biochar for improving soil characteristics. *Biomass Conversion and Biorefinery*. 11(3), 1041-1051.
- Ünal, H., Alibaş, K. (2006). Determining of the Suitable Burning Method for. *Journal of Applied Sciences*. 6(2), 435-444.
- Vance, C.P., Kirk, T.K., Sherwood, R.T. (1980). Lignification as a mechanism of disease resistance. *Annu Rev Phytopathol*. 18: 259–288.
- Viana, H.D.S., Rodrigues, A.M., Godina, R., Matias, J.D.O., Nunes, L.J R. (2018). Evaluation of the physical, chemical and thermal properties of Portuguese maritime pine biomass. *Sustainability*, 10(8).
- Vusić, D., Vujančić, F., Pešić, K., Šafran, B., Jurišić, V., Zečić, Ž. (2021). Variability of Normative Properties of Wood Chips and Implications to Quality Control. *Energies*. 14(13): 3789.
- Williams, C L., Emerson, R.M., Tumuluru, J. S. (2017). Biomass Compositional Analysis for Conversion to Renewable Fuels and Chemicals. In (Ed.), *Biomass Volume Estimation and Valorization for Energy*. IntechOpen. <https://doi.org/10.5772/65777>
- Yu, J., Paterson, N., Blamey, J., Millan, M. (2017). Cellulose, xylan and lignin interactions during pyrolysis of lignocellulosic biomass. *Fuel*, 191, 140-149.
- Zhu, B., Chen, G., Cao, X., Wei, D. (2017). Molecular characterization of CO<sub>2</sub> sequestration and assimilation in microalgae and its biotechnological applications. *Bioresour Technol.*; 244: 1207-1215.



## EVALUATION OF THE PROCESSING AND UTILIZATION OF INVASIVE HERBACEOUS PLANTS FOR THE PRODUCTION OF BIOFUEL PELLETS

Gvidas GRAMAUSKAS, Algirdas JASINSKAS\*, Ramūnas MIELDAŽYS

\*E-mail of corresponding author: algirdas.jasinskas@vdu.lt

Department of Agricultural Engineering and Safety, Faculty of Engineering, Agriculture Academy, Vytautas Magnus University, Studentu str. 15A, Akademija, LT-53362 Kaunas reg., Lithuania

### ABSTRACT

*The object of this research was the biomass of two harvested invasive herbaceous plants, and one of pine tree. This plant biomass was harvested, dried and utilized for pressed biofuel production. After harvesting and drying, plant biomass was chopped and milled, and later pressed to cylindrical 6 mm diameter pellets, which were produced using a granulator of low power (120–150 kg h<sup>-1</sup>).*

*After chopped plant milling, it was determined the fractional composition of the mill in all three samples: 60–75% of mill particle size was less than 2.0 mm. So, this milling quality met the requirements for the production of pellets. After analysis of pellet biometrical properties these parameters were measured: the length of produced pellets ranged from 23 to 31 mm, and the diameter was sufficiently stable and varied from 6.0 to 6.2 mm.*

*After investigation of pellet physical–mechanical and elemental properties it was determined that the bulk density of pellets (moisture content 8–9%) reached 1057–1100 kg m<sup>-3</sup>. Determined lower calorific value of investigated pellets varied from 16.9 MJ kg<sup>-1</sup> to 19.0 MJ kg<sup>-1</sup>. Harmful gas emissions during burning of the tested biofuel pellets were also evaluated. These emissions from the combustion of pellets were sufficiently low and did not exceed the allowed values. Finally, it can be stated, that all investigated granules meet the most important requirements for the quality of biofuel, and it can be prepared and used for energy purposes, for burning in special boilers suitable for granular biofuel.*

**Keywords:** *Sosnowsky's hogweed, Giant knotweed, pellets, biofuel, properties, emissions.*

## INTRODUCTION

Recently, more and more attention has been paid in the field of agricultural science to the use of biomass of new energy plants for sustainable energy. Biomass is classified as one of the main sources of renewable energy. Compared to solid fossil fuels, the use of plant-based biofuel significantly reduces the "greenhouse" effect; CO<sub>2</sub> emissions are approximately zero, since the amount of CO<sub>2</sub> released during combustion is used to produce organic matter during photosynthesis (Vares et al., 2005).

The rapid spread of invasive plants poses an increasing threat to natural ecosystems in all countries of the world. In addition, invasive plants can also pose a risk to public health and the economy. As a result, several management strategies have been developed. Among them, mechanical (e.g., hoeing and digging) and chemical (e.g., herbicides) control methods are commonly used. Although these methods are effective, they are often very capital and human resource intensive, and there is no reversible energy cycle. In addition, the use of herbicides or other chemical control agents may cause unintended risks to native species and public health. Therefore, it is very important to develop innovative and economical strategies for the control of invasive plants (Le Roux, 2021).

Some countries have been developing technologies and conducting research into successful usage of invasive plants for biofuel production. These technologies can range from solid biofuel production to fermentation to produce non solid biofuels (Younho et al. 2022)

Widespread invasive plants in Lithuania are Sosnowsky's hogweed and Giant knotweed. These plants accumulate a lot of biomass, which can be used as biofuel after being chopped, dried and compressed. This would potentially pay for technologies to eradicate these invasive herbaceous plants. These plants' energy content was comparable to that of wheat straw. During the first year, they generated 8 to 14 t dry matter per hectare (Žaltauskas et al., 2001). In addition, invasive herbaceous plants do not need to be sown, fertilized, or maintained so their cultivation costs are zero. For this reason, their stored energy in the form of biomass should offset the costs of harvesting and preparation for burning (Startseva et al., 2021).

Sosnowsky's hogweed (*Heracleum sosnowskyi*) is a perennial herbaceous, monocarpic, and seed-propagated member of the *Heracleum* genus (is also known as family *Apiaceae*, synonym *Umbelliferae*). The plant's competitive abilities, which are essential for successful dissemination, are increased by seed productivity that is regarded as high (10,000–20,000 seeds per plant) and germination percentages of up to 90% in the first year (Mishyna et al. 2015). The presence of the highly toxic furanocoumarin in the plant's sap poses a major concern to the human population due to its photoallergic qualities. Large blisters and burn symptoms could appear after contact with the plant and exposure to the sun (Jakubowicz et al. 2012).

Giant knotweed (*Fallopia sachalinensis*), which originated for Eastern Asia can reach heights of 1.5 to more than 3.5 meters. The perennial plant known as knotweed emerges every year from a woody foundation. About 15 t ha<sup>-1</sup> DM (dry matter) of high productivity may be achieved by these plants. There are numerous types of knotweed, including Himalayan knotweed (*Persicaria wallichii*), Giant knotweed (*Fallopia sachalinensis*), Bohemian knotweed (*Fallopia bohemica*), and Japanese knotweed (*Fallopia japonica*) (Squires et al., 2018).



European countries have specific standards for regulating the quality of produced solid biofuel. In Sweden the standard regulating the quality of pellets is SS187120, and in Germany the standard DIN 51731 is valid, which also defines the requirements for pellets. In Europe, there is a wood pellet certification system called "ENplus", which uses CEN/TC, EN and ISO standards for solid pellet biofuel (Streikus, D., 2020).

The emission limit values of fuel-burning devices are regulated by emission standards for fuel-burning devices, approved by the Minister of the Environment of the Republic of Lithuania (LAND 43-2013). These norms regulate the pollutant limit values of burnt biofuel, including grass plants and straw. Emission limit values for new and existing plants burning biofuel with a thermal output of 0.12–1.0 MW have been determined (at a standard concentration of O<sub>2</sub> = 6% by volume) (LAND 43-2013): NO<sub>x</sub> → 750 mg Nm<sup>-3</sup>; SO<sub>2</sub> → 2000 mg Nm<sup>-3</sup>; CO → not rationed; solid particles → 800 mg Nm<sup>-3</sup>.

According to existing research results, invasive grass plants would theoretically be suitable as an additional source of biofuel, since the cultivation of invasive grasses does not use energy at all, and they need to be destroyed and removed (Papamatthaiakis et al., 2021). For harvesting them, you can use already existing agricultural aggregates, which are adapted for harvesting and chopping herbaceous plants. However, there is a lack of more detailed studies and studies with more diverse invasive herbaceous plants.

Most research tends to gravitate towards the usage of invasive herbaceous plant biomass for the production of biogas or biochar. There is a significant deficit for research that analyses invasive herbaceous plants biomass for the usage in solid biofuel production. Although there is extensive research in the usage of biogas waste products in conversion to solid biofuel (Czekala 2021).

The purpose of this research is to analyse the technologies for harvesting invasive herbaceous plants and preparing pellets. To determine the physical parameters, composition of chemical elements, and calorific value of the pellets of invasive herbaceous plants, as well as determine the emissions released during burning in a low power boiler.

## MATERIALS AND METHODS

### *Chopping and milling*

The first operation of the biomass processing technological process is to chop the harvested, dried biomass. In this study, the biomass of the invasive plants – Giant knotweed and Sosnowsky's hogweed was first dried, then chopped and milled using a drum chopper of Maral 125 forage and a Retsch SM 200 mill.

The fractional composition of milled biomass was determined by using the standard methodology EU DD CEN/TS 15149-1: 2006, and by using the sieves of different holes diameter. For this experiment a Retsch AS 200 (Fig 1.) sieve shaker was chosen. The sieve shaker consists of five sieves with holes diameter from top to bottom: 2 mm, 1 mm, 0.63 mm, 0.5 mm, 0.25 mm, 0 mm. A mass of 100 grams is sieved and after each sieve the mass remaining on each sieve is weighed, the tests are repeated 3 times.

### *Pellet Production*

A biomass granulator with a horizontal matrix was used to produce pellets. The diameter of granulator matrix holes is 6 mm and the power of the granulator is 7.5 kW.

### ***Moisture content***

To determine the moisture content of the pellets three samples of each plants biomass were taken and put into cruets. These cruets were weighed and placed into a drying cabinet. The samples were kept in the drying chamber for 24 hours at a constant 105°C temperature. After drying the dried samples and empty cruets were weighed. The moisture content of all samples was calculated including the averages with deviation.

### ***Pellet density***

In order to determine pellet density, ten produced pellets were chosen at random and weighed. The diameter and length of each pellet was measured in order to determine volume of each pellet. With these measurements each pellets density was determined.

### ***Compression resistance***

Five produced pellets from each different plant were again chosen at random and tested in a laboratory. INSTRON 5965 (Fig 2.) compression testing tool was used for this experiment. Each pellet was placed in horizontal direction and crushed until it reached a critical point. The data was tracked using the tools' software "Bluehill" and resistance to compression of each pellet was determined.



**Figure 1** Retsch AS 200



**Figure 2** Instron 5965

### ***Elemental composition, ash content and calorific value***

All of the experiments that determined the Elemental composition, ash content and calorific value were done in the Lithuanian Institute of Energy, Thermal Equipment Testing and Research laboratory. The methodology of these tests is valid in Lithuania and other European countries. For ash content in device No. 8B/5 – LST EN 14775:2010, for elemental composition in device No. 8B/3 – LST EN 15104:2010 and for calorific value in device No. 8B/2 – LST EN 14918:2010.

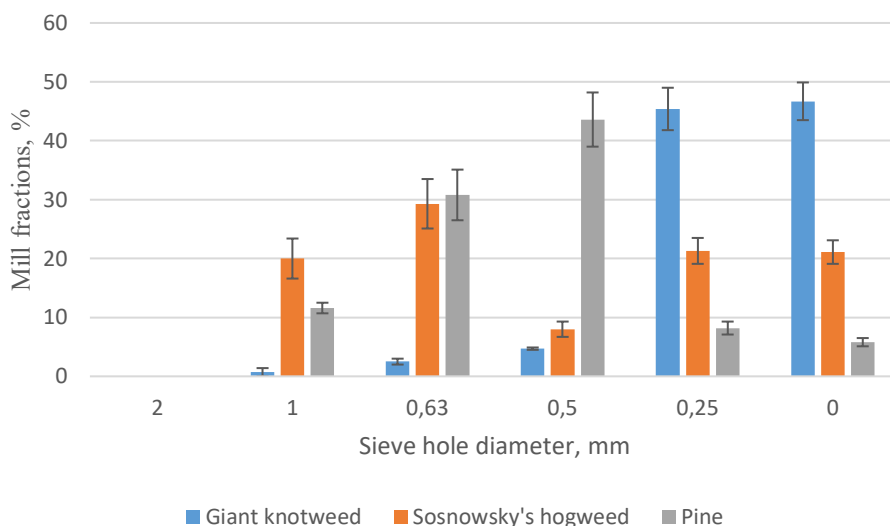
### ***Harmful emissions***

The emissions of burning biofuel produced from invasive herbaceous plants such as Sosnowsky's hogweed and Giant knotweed have been analysed in Lithuanian Energy

Institute, Thermal Equipment Testing and Research laboratory. Experiment was fulfilled in accordance with the requirements of the LST EN 15104:2010 standard by burning produced pellets. The amounts of total carbon, hydrogen, nitrogen, sulphur and oxygen formed during combustion were measured by combustion product analysers: Datatest 400CEM, analyser VE7 (Sakalauskas et al., 2014).

## RESULTS AND DISCUSSION

The fractional composition of milled biomass from Giant knotweed, Sosnowsky's hogweed and control sample of pine was determined and presented in Fig. 3.



**Figure 3** Fractional composition of milled plant biomass

The experiment shows that there are no pieces larger than 2 mm in diameter. It is also of note that pine wood biomass tended to produce larger pieces in diameter as compared to herbaceous knotweed and hogweed. Biomass of this fractional composition is suitable to produce pellets.

The pellets were produced and their mechanical-physical properties in Table 1 were presented. The pellet diameter corresponded to the diameter of the granulator matrix which was 6 mm, the extra diameter of the pellets is attributed to the heat expansion of material.

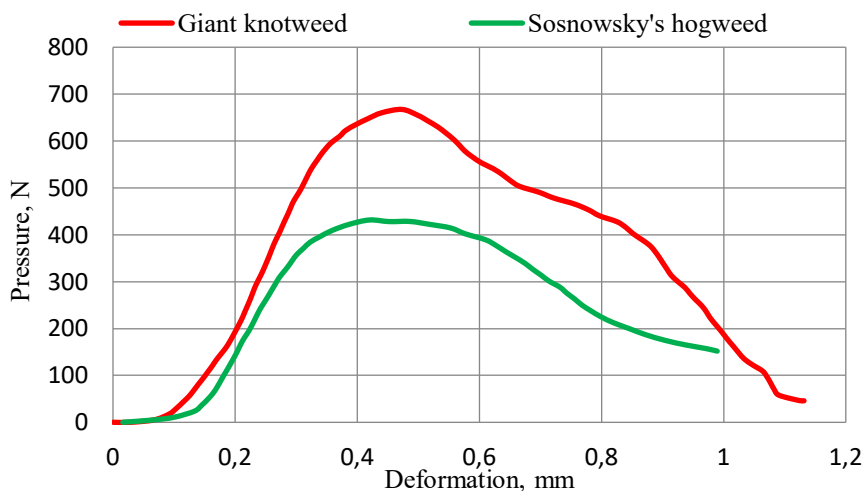
From Table 1 we can see that the parameters of pellets from invasive herbaceous plants do not differ much from woody pine biomass. The density of the pellets of herbaceous plants adjusted for variance is roughly similar to pine pellets. The only difference is the length of the pellets. The pellets that were produced from pine biomass were longer, their mass was larger, but the density was roughly equivalent to the herbaceous invasive plant pellets. This means

that the pellets produced from herbaceous invasive plants such as Sosnowsky's hogweed and Giant knotweed is viable for solid biofuel production.

**Table 1.** Physical-mechanical properties of pellets.

Plant species	Pellet parameters				
	Diameter $d$ , mm	Length $l$ , mm	Volume $V$ , $\text{m}^3$	Mass $m$ , g	Density $\rho$ , $\text{kg m}^{-3}$
Sosnowsky's hogweed	$6.20 \pm 0.22$	$23.58 \pm 0.93$	$(7.52 \pm 0.59) \times 10^{-7}$	$0.65 \pm 0.08$	$1085.3 \pm 21.5$
Giant knotweed	$6.13 \pm 0.09$	$23.12 \pm 0.84$	$(6.82 \pm 0.25) \times 10^{-7}$	$0.69 \pm 0.04$	$1057.5 \pm 73.6$
Pine	$6.09 \pm 0.13$	$30.73 \pm 0.88$	$(8.95 \pm 0.83) \times 10^{-7}$	$1.05 \pm 0.14$	$1100.9 \pm 34.0$

The pellets produced from invasive herbaceous plants, Sosnowsky's hogweed and Giant knotweed were subjected to a test where their strength was determined (Fig 4.). This test makes sure that the pellets are not destroyed during the transportation and utilization process.



**Figure 4** Compressive resistance of pellets

The resistance to compression test shows that the pellets produced from invasive herbaceous plants Sosnowsky's hogweed and giant knotweed adhere to the quality standard required by the European Union. The pellets produced will not degrade when packaging or transporting.

Research on the burning of Sosnowsky's hogweed and giant knotweed pellets was carried out at the Lithuanian Energy Institute, in the thermal equipment research and testing

laboratory. Sosnowsky's hogweed and giant knotweed pressed biofuel pellets were completely burned and their emissions were measured, which are presented in Table 2. Pellets made from pine wood were also burned to compare the differences in emissions.

The pellets made from invasive herbaceous plants produce more carbon monoxide than pellets from pine wood, but the parameters are within the European standards. The usage of these plants for biofuel offsets the energy cost of exterminating them from the ecosystem.

**Table 2.** Emissions of Sosnowsky's hogweed, Giant knotweed and pine pellets

Plant species	CO <sub>2</sub> %	CO ppm	NO <sub>x</sub> ppm	C <sub>x</sub> H <sub>y</sub> ppm
Sosnowsky's hogweed	4.59	1778.44	121.31	92.45
Giant knotweed	5.51	915.30	67.40	66.00
Pine	4.70	187.50	43.31	9.33

After analysis of research results, we can see that the giant knotweed is more suitable for solid biofuel production. Although the biomass from Sosnowsky's hogweed produces more volatile end products, it can be used as intermediate material for the production of solid biofuel. The chemical and elemental composition of Sosnowsky's hogweed and Giant knotweed have been analysed and evaluated for the production of solid biofuel (Table 3).

**Table 3.** Elemental properties of Sosnowsky's hogweed, Giant knotweed and pine.

Parameter	Sosnowsky's hogweed	Giant Knotweed	Pine
Ash content, %	7.94 ± 2.20	4.28 ± 0.01	1.13 ± 0.03
Lower calorific value, MJ kg <sup>-1</sup>	16.88 ± 1.31	18.96 ± 0.28	19.81 ± 0.29
Higher calorific value, MJ kg <sup>-1</sup>	15.86 ± 1.04	17.73 ± 0.33	18.63 ± 0.33
C, %	48.16 ± 1.66	47.42 ± 1.08	49.53 ± 1.1
H, %	4.56 ± 0.55	5.98 ± 0.43	4.75 ± 0.05
N, %	0.74 ± 0.37	0.71 ± 0.30	< 0.01 ± 0.0
S, %	0.07 ± 0.0	0.05 ± 0.26	< 0.01 ± 0.0
O, %	38.45 ± 0.0	41.55 ± 0.0	43.59 ± 0.0
Cl, %	0.09 ± 0.0	0.26 ± 0.0	0.06 ± 0.0

The pellets produced from invasive herbaceous plants were inferior to biomass that was produced from woody pine, but they did comply with the European standards mentioned above. The ash content of herbaceous plants is higher than that of wood biomass, but the parameters of ash content is equivalent.

Comparing the values with K. Paramonova's (Paramonova et al., 2021) research the lower calorific value of Sosnowsky's hogweed partly seems to be similar – 16.5 MJ kg<sup>-1</sup>, to that of which was calculated in this paper at 16.88 ± 1.31 MJ kg<sup>-1</sup>. These parameters show that the biomass from Giant knotweed and Sosnowsky's hogweed are acceptable for solid biofuel production.

## CONCLUSIONS

There were investigated the possibilities of utilization the invasive plants, such as the Sosnowsky's hogweed and Giant knotweed utilization for production of solid biofuel and use for energy purposes. There were investigated pellet physical–mechanical and elemental properties, and it was determined that the bulk density of pellets reached 1057–1100 kg m<sup>-3</sup>, and lower calorific value of biofuel varied from 16.9 MJ kg<sup>-1</sup> to 19.0 MJ kg<sup>-1</sup>.

Harmful gas emissions during burning of investigated biofuel pellets were sufficiently low and did not exceed the allowed values, so it can be stated, that all investigated granules meet the most important requirements for the quality of biofuel, and it can be prepared and used for burning in special boilers suitable for granular biofuel.

The biomass produced from Sosnowsky's hogweed and Giant knotweed is suitable for the production of solid renewable biofuel. The parameters and characteristics of these invasive herbaceous plants meet all required specifications of European standards. More research is required to determine the best mixture of invasive herbaceous plants and generally used woody biomass. It can be claimed that Sosnowsky's hogweed and Giant knotweed are suitable additions to currently produced woody biomass pellets. The only detriment observed is that of ash content removal, since herbaceous plants produce more ash compared to woody biomass.

## REFERENCES

- Czekala W. (2021). Solid Fraction of Digestate from Biogas Plant as a Material for Pellets Production; Energies, Nr. 14(16), 5034.
- EU DD CENT/TS 15149-1: 2006. Solid biofuels. Methods for the determination of particle size distribution. Oscillating screen method using sieve apertures of 3,15 mm and above.
- Jakubowicz, O., Żaba, C., Noawk, G., Jarmuda, S., Żaba, R., Marcinkowski, Jt. (2012). *Heracleum sosnowskyi* Manden.; Annals of Agricultural and Environmental Medicine, 19 (2), 327-328.
- Le Roux, J. (2021). The Evolutionary ecology of invasive species. India. 1–209.
- LST EN 14918:2010; (2010). „Solid biofuel. Calorific value analysis“. [In Lithuanian].
- Mishyna, M., Laman, N., Prokhorov, V., Fujii, Y. (2015). Angelicin as the principal allelochemical in *Heracleum sosnowskyi* fruit; Natural Product Communications, No. 10 (5), 767-770.
- Papamatthaiakis, N., Laine, A., Haapala, A., Ikonen, R., Kuittinen, S., Pappinen, A., Kolström, Mola-Yudego, B. (2021). New energy crop alternatives for Northern Europe: Yield, chemical and physical properties of Giant knotweed (*Fallopia sachalinensis* var. 'Igniscum') and Virginia mallow (*Sida hermaphrodita*). Fuel, 304, 121349.
- Paramonova, K., Ivanova, T., & Malik, A. (2021). Exploring the potential of invasive plant Sosnowsky's hogweed for densified biofuels production. *Știința Agricolă*, (2), 105–108.

- Sakalauskas, A., Jasinskas, A., Šarauskis, E.; Vaiciukevičius, E., Kalinauskaitė, S., Simonaitis, P. (2014). The use of perennial grasses and non-traditional herbaceous plants (silvergrass, sida, silphium, reed grasses) and their mixtures for the production of pressed biofuel: the final report of the Agriculture, Food and Fisheries RTD project. 68. [In Lithuanian]
- Squires V. R., Dengler J., Hua L., Feng H. (2018). Grasslands of the World: Diversity, Management and Conservation. Nature, 426.
- Streikus, D. (2020). Assessment of technologies for processing and usage of coarse-stem and fibrous plants for energy purposes. Doctoral thesis. Vytautas Magnus University Agriculture Academy, Lithuania.
- Vares, V., Kask, U., Muiste, P., Pihu, T., Soosaar, S. (2005). Manual for Biofuel Users. Tallinn University of Technology, 178.
- Younho S., Yoon G. L., Dae-Seok L., Dinh-Truong N., Hyeun-Jong B. (2022). Utilization of bamboo biomass as a biofuels feedstocks: Process optimization with yeast immobilization and the sequential fermentation of glucose and xylose. Fuel, vol. 307, 121892.
- Žaltauskas, A., Jasinskas, A., Kryževičienė, A. (2001). Analysis of the Suitability Tall-Growing Plants for Cultivation and Use as a Fuel. Perspective Sustainable Technological Processes in Agricultural Engineering: proceedings of the International Conference, Lithuanian Institute of Agricultural Engineering. Raudondvaris, 155-160. [In Lithuanian]

---

---





## SUSTAINABLE CROP RESIDUES POTENTIAL FOR THE PRODUCTION OF LIGNOCELLULOSIC BIOETHANOL IN SERBIA

Aleksandar NESTEROVIC\*, Djordje DJATKOV, Miodrag VISKOVIC,  
Milan MARTINOV

\*E-mail of the corresponding author: [aleksandarnesterovic@uns.ac.rs](mailto:aleksandarnesterovic@uns.ac.rs)

*University of Novi Sad, Faculty of Technical Sciences, Chair of Biosystems Engineering,  
Trg Dositeja Obradovica 6, 21102 Novi Sad, Serbia*

### ABSTRACT

*European Union (EU) promoted renewable sources (biofuels, renewable electricity) through its policy in the sector of transport to reduce greenhouse gases emissions and reach decarbonized sector in 2050. Serbia is the member of the Energy Community and thus obligated to follow EU policy in this field. Therefore, a significant uptake of alternative fuels must be facilitated in the transport sector. The objective of this paper was to investigate the sustainable potential of crop residues to produce lignocellulosic bioethanol in Serbia. The results shown that about 2.3 million tons of dry mass of crop residues are available in Serbia and that about 369 ktoe of lignocellulosic bioethanol could be produced annually. About 12%-14% of the energy needs in the national transport sector could be covered by the sustainable potential of crop residues for bioethanol from the Vojvodina region in the future. This would be 3-6 times higher than the goals set by the EU, if the energy share is considered. The surplus could be used to replace 1G biofuels produced from food/fodder and contribute to attain decarbonization goals. Future research should include the analysis of economic aspects of the lignocellulosic bioethanol use and comparison with other potential alternative fuels in Serbia.*

**Keywords:** *lignocellulosic bioethanol, crop residues, sustainable potential, Serbia*

### INTRODUCTION

In 2020, transport sector accounted for 37% of greenhouse gases (GHG) in end-use energy globally due to the high share of fossil fuels (IEA, 2021). In 2017, 96.7% of global transport energy needs were met by oil and oil derivatives (including 0.8% non-renewable electricity),

with a low share of biofuels (3.0%) and renewable electricity (0.3%) (Ebadian *et al.*, 2022). Through its strategic documents, the European Union (EU) promotes the use of alternative fuels in transport, such as biofuels, renewable electricity, and others, to achieve a reduction in GHG emissions (EC, 2019; 2021).

Biofuel is defined as liquid or gaseous fuel for transport produced from biomass, *i.e.*, organic matter obtained from plants and animals (IEA, 2011). If biofuel is produced from raw materials that can be used in human or animal nutrition, it is defined as the first-generation biofuel (1G), otherwise it is the second-generation (2G), and both types are predominantly used in practice. Also, there are third and fourth generation (3G and 4G) biofuels that are in the development and research phase, and they are obtained mainly from algae (Nigam and Singh, 2011; Ambaye *et al.*, 2021). In addition to the above classification, which is one of the most represented in the literature, there is also another according to the maturity technology. In that case, there are two categories, conventional and advanced biofuels. Conventional biofuels include 1G, *i.e.*, bioethanol obtained from the fermentation of sugar or starch, biodiesel (FAMA– Fatty Acid Methyl Esters and FAEE–Fatty Acid Ethyl Ester) obtained from fatty acid esters of vegetable oils, but also biomethane obtained by removing CO<sub>2</sub> from biogas produced by anaerobic fermentation of agricultural crops (IEA, 2011; SDSN/FEEM, 2021). Advanced biofuels include 2G and more advanced, and some of them are lignocellulosic bioethanol (LCB) primarily produced from crop residues such as straw and corn stover, biomethane from manure or other organic waste, hydrotreated vegetable oils (HVO) from used cooking oil, Fischer-Tropsch fuels from products of the gasification of lignocellulosic biomass and waste, *etc.* (Brown *et al.*, 2020; SDSN/FEEM, 2021).

Decarbonization is a challenge and a future task of energy and climate policy in Europe defined in numerous documents governing these fields. The European Green Deal (EC, 2019) generally defines the goals to reach a Europe neutral in terms of GHG emissions by 2050. In the EU, transport (including road, air, and water) causes 27% of total GHG emissions, and the European Green Deal defines the goal of reducing GHG emissions from transport by 90% by 2050. Alternative fuels should be promoted in air transport, water, and heavy road transport, where the electrification of transport from renewable energy sources (RES) is challenging. Therefore, the use of RES is key to achieve climate goals, as it, together with renewable electricity, eliminates the use of fossil fuels.

According to the RED II– Renewable Energy Directive (EC, 2018), the minimum share of RES in the final consumption of energy in the transport sector should be 14% by 2030. Thereby, advanced biofuels and biogas produced from the raw materials listed in Part A of Annex IX, such as crop residues should contribute to total energy demand with at least 3.5%. In line with Fit for 55 (EC, 2021) and REPowerEU (EC, 2022) packages, the share of advanced biofuels produced from such raw materials should be at least 2.2%, while the goal for the transport sector is that the application of RES should result in a reduction of GHG emissions by at least 13% and 16% in 2030, respectively. For 1G biofuels, the maximum final consumption share can be 7% in all three mentioned EU documents.

Since Serbia is a member of the Energy Community (EnC), the contract has ratified to apply EU directives in the field of RES, *i.e.*, alternative fuels and their application in the transport sector in the decarbonization process (MMERS, 2006). According to the National Renewable Energy Action Plan of the Republic of Serbia (MEDEORS, 2013), and following the RED I directive and the Decision of the EnC Ministerial Council of October 18, 2012 (D/2012/04/MC – EnC), the target for the share RES in the transport sector should be 10% in

2020. However, it was 1.17% in 2020, *i.e.*, about 24.8 ktOE that is less than 12% of the defined goal (Eurostat, 2022a). The entire final use of energy from RES was related to electricity in railway subsector, *i.e.*, there was no use of biofuels and other alternative fuels in the transport sector. One of the reasons for this is that the legal framework for the obligation to use biofuels in the transport sector was adopted only in 2019 (MMERS, 2019).

The objective of this paper was to investigate the sustainable potential of crop residues to produce LCB in Serbia. When assessing the sustainable potential of crop residues for LCB, a comprehensive methodology has been applied, considering technical, environmental, and socio-economic aspects. The further objective was to assess possibilities to attain the decarbonization goals in the transport sector with available resources in Serbia, as well as the analysis on the possible allocation of surplus crop residues amounts to other biofuel types or their potential use in other sectors beyond transport.

## MATERIALS AND METHODS

### Materials

#### *Annual crop production*

Table 1 presents data on average moisture content, yields and crop production in Serbia in the period from 2005 to 2021 (SORS, 2022; Eurostat, 2022b). These data were used to determine the crop residues' potentials as a raw material to produce LCB.

**Table 1** Average values of crop production in Serbia in the period 2005-2021

	Moisture content, %	Yield, t <sub>FM</sub> ha <sup>-1</sup>	Crop production, kt <sub>FM</sub> a <sup>-1</sup>
Wheat	14	4.3	2,589.1
Barley	14	3.7	351.6
Rye	14	2.6	13.5
Oat	14	2.4	80.4
Corn	14	6.2	6,215.0
Rapeseed	9	2.6	45.5
Sunflower	9	2.5	492.1
Soybean	14	2.7	478.0

FM: fresh matter.

#### *Energy consumption in transport sector of Serbia*

In Serbia, in 2020, the final energy consumption in the transport sector was 2,348 ktOE, while depending on the type of scenario, energy needs is estimated to be in the range of 2,400-2,532 ktOE in 2030, and in the range of 2,204-2,639 ktOE in 2050 (MMERS, 2022). These scenarios were developed to create the Integrated National Energy and Climate Plan, and one

should be selected and included in this strategic document. These amounts of energy were used to estimate the share of energy that could be covered by LCB.

## **Methods**

### *Defining the crop residues potentials*

Theoretical potential. The theoretical potential was determined using the data from Table 1 and the method developed by Scarlat et al. (2010) using the parameter residue to product ratios (RPR). RPR values for all crops except soybean were calculated and presented in Table 2. Crop production (Table 1) converted to dry matter multiplied by the RPR values for each crop represent the amount of aboveground crop residues based on dry matter, and this value represents the theoretical potential.

**Table 2** Values of residue to product ratios

	<b>RPR</b>
Wheat	1.1
Barley	1.0
Rye	1.2
Oat	1.1
Corn	1.0
Rapeseed	1.6
Sunflower	2.2
Soybean <sup>a</sup>	1.5

<sup>a</sup>Graham et al, 2007

### *Technical potential*

The technical potential represents the amount of crop residues that can be harvested from the field, and it depends on the equipment used and the condition of the straw and stover. In this paper, the technical potential is estimated using literature data on the efficiency of harvesting procedures, agricultural practices applied in Serbia, and theoretical potential. The following values for the specific crop residues were derived by the literature review (Golub et al., 2012; 2013; Veselinov et al., 2015; Martinov et al., 2019): wheat, barley, oat, and rye (50%), corn (48%), rapeseed (49%), sunflower (32%), and soybean (40%). The values were determined based on harvesting procedures applied in Serbia and they include all losses that occur during the collection of crop residues.

### *Sustainable potential*

Sustainable potential refers to the amounts of crop residues that can be removed from the field without soil fertility depletion (maintaining of organic matter and organic carbon in the soil and protection from erosion). This potential was evaluated as the share of the theoretical potential. A review of the literature (Scarlat et al., 2010; Golub et al., 2012; 2013; 2016; Veselinov et al., 2015) found that for wheat, rye, barley, and oat the sustainable potential is lower than the technical potential, and amounts to 40%, while for soybean the rate is the same

for both potentials and amounts to 40%, and for corn, rapeseed, and sunflower the value of the technical potential was applied because the sustainable potential is higher than the technical potential.

#### *Sustainable potential for LCB*

Based on the data on the farm size and the acreage for certain crops, a classification was carried out into small and large farms (SORS, 2022). This information was used to determine the possibility of collecting crop residues, since it determines the harvesting procedure. Large farms were considered for the sustainable potential, because it is possible to collect larger amounts of crop residues on them, due to the application of adequate agricultural mechanization that large farms have. For the region of Vojvodina and Belgrade, farms that have planted crops on 5 ha and more were considered. For other regions in Serbia, farms that have planted crops on 10 ha or more were considered due to fragmentation of plots, hilly terrain, and other logistical problems.

Finally, the allocation of crop residues for other uses was carried out. Crop residues are used as bedding material for cattle but also for heating purposes. These amounts were subtracted to obtain the sustainable potentials. The amounts of crop residues used for bedding were determined based on the research of Viskovic et al. (2022), which elaborated the manure types and its potential in Serbia. It is assessed that about 1.5 million tons of dry mass per year of straw is used for these purposes. For heating purposes, it is estimated that crop residues, primarily straw, are used on average slightly less than 200,000 tons of dry mass per year in Serbia. This amount was calculated by considering the need for thermal energy and then subtracting other energy sources that fall into the records, such as firewood, natural gas, district heating, etc.

#### *Defining the potential bioethanol production*

Using the sustainable potential of crop residues for LBC and yields of bioethanol from different crop residues (Table 3), the potential bioethanol that could be produced in Serbia was assessed. The bioethanol yields were determined by literature review as the average values for each crop residue (Sharma et al., 2002; Kim and Dale, 2004; Kahr et al., 2013; Kuglarz et al., 2018; Kim, 2018; Tse et al., 2021).

**Table 3** Bioethanol yield for crop residues

	<b>Yields, L t<sub>DM</sub><sup>-1</sup></b>
Wheat	334.9
Barley	310.0
Rye	351.0
Oat	294.6
Corn	355.1
Rapeseed	178.4
Sunflower	146.1
Soybean	392.1

DM: dry matter.

*Assessment of attaining decarbonization goals*

Following the goals set by the EU, i.e., valid RED II as well as Fit for 55 and REPowerEU packages, it was determined to what extent the potential LCB production could cover energy needs in the transport sector in Serbia in 2030 and 2050. The possibility of reaching the goals of decarbonization was checked by the ratio of the energy potential of LCB and the energy needs in the transport sector. In this way, it will be seen to what extent Serbia can cover the energy needs in the transport sector from its sources using advanced biofuels.

**RESULTS AND DISCUSSION**

The assessed potentials (theoretical, technical, sustainable and for LCB) of crop residues are presented in the Table 4. The sustainable potential of crop residues for LCB amounts to about 2.3 million tons of dry matter annually. Corn stover shows the largest potential, and the main reason for this is that corn is the most represented crop in Serbia. Wheat straw has a significantly lower sustainable potential for LCB compared to the sustainable and the technical potential, since it is already allocated for bedding and heating purposes.

**Table 4** Potential of crop residues in Serbia

	<b>Theoretical, kt<sub>DM</sub> a<sup>-1</sup></b>	<b>Technical, kt<sub>DM</sub> a<sup>-1</sup></b>	<b>Sustainable, kt<sub>DM</sub> a<sup>-1</sup></b>	<b>Sustainable for LCB, kt<sub>DM</sub> a<sup>-1</sup></b>
Wheat	2,404.5	1,198.3	958.6	91.2
Barley	309.1	154.1	123.3	6.8
Rye	14.3	7.1	5.7	0.3
Oat	78.3	39.1	31.3	1.4
Corn	5,381.9	2,577.8	2,577.8	1,745.1
Rapeseed	66.6	32.5	32.5	31.9
Sunflower	976.9	312.8	312.8	297.2
Soybean	616.6	246.6	246.6	84.7
<b>TOTAL</b>	<b>9,848.2</b>	<b>4,568.3</b>	<b>4,288.6</b>	<b>2,258.6</b>

DM: dry matter.

Table 5 shows the energy potential of LCB that could be obtained from the determined sustainable potential. The assessed energy potential of LCB from crop residues in Serbia is about 369 ktoe. About 84% of LCB is obtained from corn stover, which represents the largest share, while rye straw has the smallest contribution, about 0.01%.

If the energy potential of LCB obtained from the considered crop residues was compared to the energy needs in the transport sector in Serbia in 2020, it could cover about 16%. This energy of LCB could cover between 14%-15% of the energy needs in the transport sector in Serbia in 2030. In 2050, that share would be in the range of 14%-17%.

**Table 5** Energy potential of LCB in Serbia

	LCB, m <sup>3</sup> a <sup>-1</sup>	LCB, ktoe a <sup>-1</sup>	LCB energy share, %
Wheat	30,539.75	15.32	4.15
Barley	2,109.47	1.06	0.29
Rye	108.40	0.05	0.01
Oat	423.85	0.21	0.06
Corn	619,694.61	310.82	84.29
Rapeseed	5,696.09	2.86	0.78
Sunflower	43,408.64	21.77	5.90
Soybean	33,209.54	16.66	4.52
<b>TOTAL</b>	<b>735,190.35</b>	<b>368.75</b>	<b>100.00</b>

The region of Vojvodina, which is a typical agricultural region in the northern part of Serbia, could provide sufficient crop residues to meet the needs of the sustainable potential. About 84% of the sustainable potential for LCB could be collected only from this region, *i.e.*, to produce about 308 ktoe of LCB. This is sufficient to cover around 12%-14% of energy needs in the transport sector in Serbia in the future.

## CONCLUSIONS

The obtained results showed that the sustainable crop residues to produce LCB in Serbia could significantly exceed the goals set by the EU. In this way, Serbia could achieve significant progress in the decarbonization of the transport sector and increase its energy independence. By using about 24% of the defined sustainable potential, the requirements set by the RED II directive could be met, whereby for the Fit for 55 and the REPowerEU package by 15%. The sustainable potential of crop residues for LCB in Vojvodina, a typical agricultural region, could be more efficiently utilized, due to a more appropriate logistic aspects and related lower costs. The surplus could be used to reduce the use of 1G bioethanol by this or another biofuel production pathway and thus further reduce GHG emissions in the transport sector and contribute attaining the decarbonization goals. For example, biomethane for the transport sector could be produced by anaerobic digestion of crop residues. The surplus could be used in another sectors beyond transport to contribute to the corresponding decarbonization goals as well, *e.g.*, in the heating & cooling sector or biogas for the electricity generation. Future research should include a detailed analysis of the economic parameters of the LCB uptake in Serbia. This includes the purchase price of raw materials (crop residues), investment and operating costs for the considered technologies. Thereby, the resulting LCB production costs would give more comprehensive insight in its applicability comparing with other alternative fuels.

## ACKNOWLEDGEMENTS

This research was financed by the project of the Department of Environmental Engineering at the Faculty of Technical Sciences– Development of innovative engineering approaches to improve the environment and occupational safety (*Razvoj inovativnih inženjerskih pristupa za unapređenje stanja životne i radne sredine*).

## REFERENCES

- Ambaye, T.G., Vaccari, M., Bonilla-Petriciolet, A., Prasad, S., Van Hullebusch, E.D., Rtimi, S. (2021). Emerging technologies for biofuel production: A critical review on recent progress, challenges and perspectives. *Journal of environmental management*, 290, 112627.
- Brown, A., Waldheim, L., Landälv, I., Saddler, J., Ebadian, M., McMillan, J.D., Bonomi, A., Klein, B. (2020). Advanced biofuels—potential for cost reduction. *IEA Bioenergy*.
- Ebadian, M., Saddler, J., McMillan, D.J. (2022). Implementation Agendas: Compare-and-Contrast Transport Biofuels Policies (2019-2021 Update). *IEA Bioenergy*.
- European Commission (EC). (2022). Communication From the Commission to the European Parliament, the European Council, the Council, the European Economic and Social Committee and the Committee of the Regions REPowerEU Plan (COM(2022) 230 final).
- European Commission (EC). (2021). Communication from the Commission to the European Parliament, the Council, the European Economic and Social Committee and the Committee of the Regions 'Fit for 55': delivering the EU's 2030 Climate Target on the way to climate neutrality (COM/2021/550 final).
- European Commission (EC). (2019). Communication From the Commission to the European Parliament, the European Council, the Council, the European Economic and Social Committee and the Committee of the Regions: The European Green Deal (COM/2019/640 final).
- European Commission (EC). (2018). Directive (EU) 2018/2001 of the European Parliament and of the Council of 11 December 2018 on the promotion of the use of energy from renewable sources. *Official Journal of the European Union*, L 328/82.
- Eurostat. (2022a). Short Assessment of Renewable Energy Sources (SHARES) summary results 2020. (<https://ec.europa.eu/eurostat/documents/38154/4956088/SUMMARY-results-SHARES-2020.xlsx/e1197d70-9ef0-ba1f-193b-cab0dcf9b13f?t=1642578001746>).
- Eurostat. (2022b). Database of the Eurostat. ([https://ec.europa.eu/eurostat/databrowser/view/APRO\\_CPSH1\\_custom\\_3923844/default/table?lang=en](https://ec.europa.eu/eurostat/databrowser/view/APRO_CPSH1_custom_3923844/default/table?lang=en)) (accessed November 2022).
- Golub, M., Martinov, M., Bojic, S., Viskovic, M., Djatkov, Dj., Dragutinovic, G., Dallemand, F.J. (2016). Investigation on Possibilities for Sustainable Provision of Corn Stover as an Energy Source: Case Study for Vojvodina. *AMA-Agric. Mech. Asia Afr. Lat. A.* 47(4), 8-15.
- Golub, M., Martinov, M., Višković, M., Djatkov, Dj., Veselinov, B., Bojic, S. (2013). Harvestable and on-field remaining crop residues of wheat and soybean. In *Proc. 41<sup>st</sup> International Symposium Agricultural Engineering: Actual Tasks on Agricultural Engineering*, 301-312. Opatija, 19<sup>th</sup>-22<sup>nd</sup> February.
- Golub, M., Đatkov, Đ., Bojić, S., Višković, M., Martinov, M. (2012). Ukupan i raspoloživ prinos žetvenih ostataka suncokreta (*Total and available yield of sunflower harvest residues*). *Cont. Agr. Engng.* 38(1), 39-47.
- Graham, R.L., Nelson, R., Sheehan, J., Perlack, R.D., Wright, L.L. (2007). Current and potential US corn stover supplies. *Agronomy Journal*, 99(1), 1-11.



- IEA. (2021). World Energy Outlook 2021. International Energy Agency (IEA), Paris, (<https://www.iea.org/reports/world-energy-outlook-2021>).
- IEA. (2011). Technology Roadmap - Biofuels for Transport. International Energy Agency (IEA), Paris.
- Kahr, H., Wimberger, J., Schürz, D., Jäger, A. (2013). Evaluation of the biomass potential for the production of lignocellulosic bioethanol from various agricultural residues in Austria and Worldwide. *Energy Procedia*, 40, 146-155.
- Kim, S. (2018). Evaluation of alkali-pretreated soybean straw for lignocellulosic bioethanol production. *International Journal of Polymer Science*, 2018.
- Kim, S., Dale, B.E. (2004). Global potential bioethanol production from wasted crops and crop residues. *Biomass and bioenergy*, 26(4), 361-375.
- Kuglarz, M., Alvarado-Morales, M., Dąbkowska, K., Angelidaki, I. (2018). Integrated production of cellulosic bioethanol and succinic acid from rapeseed straw after dilute-acid pretreatment. *Bioresource technology*, 265, 191-199.
- Martinov, M., Djatkov, Dj., Viskovic, M. (2019). Potentials of crops residues – A case study for the province Vojvodina. *Die Bodenkultur: Journal of Land Management, Food and Environment*, 70, 181-188.
- Ministry of Energy, Development and Environmental Protection of Republic of Serbia (MEDEORS). (2013). National Renewable Energy Action Plan of the Republic of Serbia. Ministry of Energy, Development and Environmental Protection, Belgrade, Serbia.
- Ministry of Mining and Energy of Republic of Serbia (MMERS). (2022). Integrated national energy and climate plan of the RS for the period from 2021 to 2030, including the perspective until 2050. (<https://www.mre.gov.rs/lat/dokumenta/strateska-dokumenta/integrirani-nacionalni-energetski-i-klimatski-plan-republike-srbije-za-period-2021-do-2030-sa-vizijom-do-2050--godine>) (accessed November 2022).
- Ministry of Mining and Energy of Republic of Serbia (MMERS). (2019). Regulation on the share of biofuels on the market. Official Gazette of the Republic of Serbia 71/2019-3, Belgrade, Serbia.
- Ministry of Mining and Energy of Republic of Serbia (MMERS). (2006). Law on the Ratification of the Agreement on the Establishment of the Energy Community between the European Community and the Republic of Albania, the Republic of Bulgaria, Bosnia and Herzegovina, the Republic of Croatia, the Former Yugoslav Republic of Macedonia, the Republic of Montenegro, Romania, the Republic of Serbia, and the United Nations Interim Mission in Kosovo in accordance with Resolution 1244 of the Security Council of the United Nations. Official Gazette of the Republic of Serbia 62/2006, Belgrade, Serbia.
- Nigam, P.S., Singh, A. (2011). Production of liquid biofuels from renewable resources. *Progress in energy and combustion science*, 37(1), 52-68.
- Scarlat, N., Martinov, M., Dallemand, J.F. (2010). Assessment of the availability of agricultural crop residues in the European Union: potential and limitations for bioenergy use. *Waste management*, 30(10), 1889-1897.
- SDSN/FEEM. (2021). Roadmap to 2050: The Land-Water-Energy Nexus of Biofuels. Sustainable Development Solutions Network (SDSN) and Fondazione Eni Enrico Mattei (FEEM), New York. (<https://roadmap2050.report/static/files/roadmap-to-2050-biofuels.pdf>)
- Sharma, S.K., Kalra, K.L., Grewal, H.S. (2002). Fermentation of enzymatically saccharified sunflower stalks for ethanol production and its scale up. *Bioresource technology*, 85(1), 31-33.
- Statistical Office of the Republic of Serbia (SORS). (2020). Database of the SORS. (<https://data.stat.gov.rs/Home/Result/130102?languageCode=en-US>) (accessed November 2022).
- Tse, T.J., Wiens, D.J., Reaney, M.J. (2021). Production of bioethanol—A review of factors affecting ethanol yield. *Fermentation*, 7(4), 268.

- Veselinov, B., Martinov, M., Golub, M., Višković, M., Bojić, S., Đatkov, Đ. (2015). Potencijal žetvenih ostataka uljane repice u Srbiji (*Potentials of rapeseed crop residues in Serbia srp.*). *Agricultural engineering* 40(3), 59-68.
- Viskovic, M., Djatkov, Dj., Nesterovic, A., Martinov, M., Cvetkovic, S. (2022). Stajnjak u Srbiji – količine i emisije gasova s efektom staklene bašte (*Manure in Serbia: Quantities and greenhouse gas emissions srp.*). *J. Agric. Sci. (Belgr.)* 67(1), 29-46.



## ANALYSIS OF FIBRES EXTRACTED FROM CORN HUSK

Zorana KOVAČEVIĆ<sup>1\*</sup>, Anja ZERGOLLERN<sup>1</sup>, Ksenija VIŠIĆ<sup>1</sup>,  
Anamarija GUDELJ - VELAGA<sup>2</sup>, Sandra BISCHOF<sup>1</sup>

\*E-mail of corresponding author: zorana.kovacevic@ttf.unizg.hr

<sup>1</sup>Department of Textile Chemistry and Ecology, Faculty of Textile Technology,  
University of Zagreb, Prilaz baruna Filipovića 28a, 10000 Zagreb, Croatia

<sup>2</sup>Faculty of Agriculture University of Zagreb, Svetošimunska cesta 25,  
10000 Zagreb, Croatia

### ABSTRACT

*The influence of the chemical modifications of the corn husk on the production of textile fibre raw material will be examined in this paper. Processing parameters will be optimized by changing the concentration of functional agents, temperature and processing time with the aim of better economic and ecological application. The efficiency of such treatment will be investigated by scanning electron microscopy (SEM) through the analysis of the transverse dimensions and overall appearance of extracted fibres.*

**Keywords:** corn husk, natural fibres, scanning electron microscopy, circular bioeconomy.

### INTRODUCTION

Along with rice and wheat, corn is one of the leading agricultural crops in the world, as well as in Croatia. Economically, it is very important because almost all parts of the plant can be used for processing (Sarker Ratna et al., 2022). Although it is most often used as a raw material in livestock nutrition, its use in recent years is oriented on the production of biogas due to the reduction of natural resources of fossil fuels, and additionally for the needs of the alcohol industry. It is also used in the food, pharmaceutical and textile industries (Milind and Isha, 2013; Bajpai, 2021), the latest will be emphasized in this paper.

Given the growing awareness of nature preservation and sustainable development, the use of natural biodegradable fibres has numerous advantages (Peran and Vujasinović, 2018). Corn fibres are relatively new to the textile industry. Natural fibres from corn are extracted from the leaves of the cob sheath (corn husk), and/or from the stem (Cheșcă et al., 2018; Daud et al., 2013; Kambli et al., 2016).

Corn husk is considered as agronomic waste. During the production of corn for animal feed, husk is thrown away and, like other organic waste, represents a challenge for the environment due to the specific method of disposal. One of the ways of using corn husk is the production of fibres (Zheng et al., 2022). The main advantage in the production of corn fibre is the possibility to grow the same raw material for food and clothing on the same land without using additional resources (Jain et al., 2017; Jain et al., 2018).

## MATERIALS AND METHODS

The corn husk were collected from the production areas of the Agricultural Institute Osijek (Figure 1).



**Figure 1** Corn husk used in the research

NaOH, urea and hydrogen peroxide ( $H_2O_2$ ) used for fibre extraction were purchased from Gram-Mol d.o.o., Croatia while Hyamine 1622 was purchased from Sigma Aldrich, Germany.

The corn husk was treated in the 2 stage process. First in the mixture of hydrogen peroxide (various concentrations – 5, 8, and 10%) and urea (6 g/L) at liquid ratio 1:40 maintaining the processing temperatures of 30, 70 and 90 °C in duration of 45 and 60 minutes (description of samples is presented in Table 1).

**Table 1** Samples description

Temperature [°C]	Time [min]	$H_2O_2$ [%]		
		5	8	10
30	45	1 a	2 a	3 a
	60	1 a'	2 a'	3 a'
70	45	1 b	2 b	3 b
	60	1 b'	2 b'	3 b'
90	45	1 c	2 c	3 c
	60	1 c'	2 c'	3 c'

After finishing the first stage, corn husks were soaked in 5% NaOH, heated to 80 °C and treated for 5 minutes. Obtained fibres were then neutralized with 10% acetic acid and rinsed with hot distilled water. Since fibres were quite stiff, they were softened in the solution of 0.5% cationic surfactant Hyamine 1622 and rinsed with cold distilled water.

Subjective assessment of samples based on visual and handle perception was conducted by three examiners who evaluated the samples with grades from 1 to 5. In visual assessment grade 1 means that samples are not in a fibre form and have very dark colour while grade 5 means that samples are in fibre form, can be separated from each other, are relatively long and have uniform colour. In handle assessment grade 1 means that sample is rough and fibres are very coarse, while grade 5 means that fibres are much finer and softer but still relatively long.

Morphology measurements were conducted using scanning electron microscope FE-SEM, MIRA II, Tescan, Czech Republic. The samples were coated in the sputter machine Q150T ES, Quorum Technologies, UK with Cr layer prior to analysis in order to minimize charging effect. Measurements were performed at 5 kV at magnifications of 500, 1000 and 1500 x using a secondary electron detector (SE). Analysis of fibre dimensions was carried out with MIRA II software.

## RESULTS AND DISCUSSION

In order to find out which formulation is the best in economic and ecological way to be applied in the process of obtaining fibres from corn husk two methods were conducted within this paper.

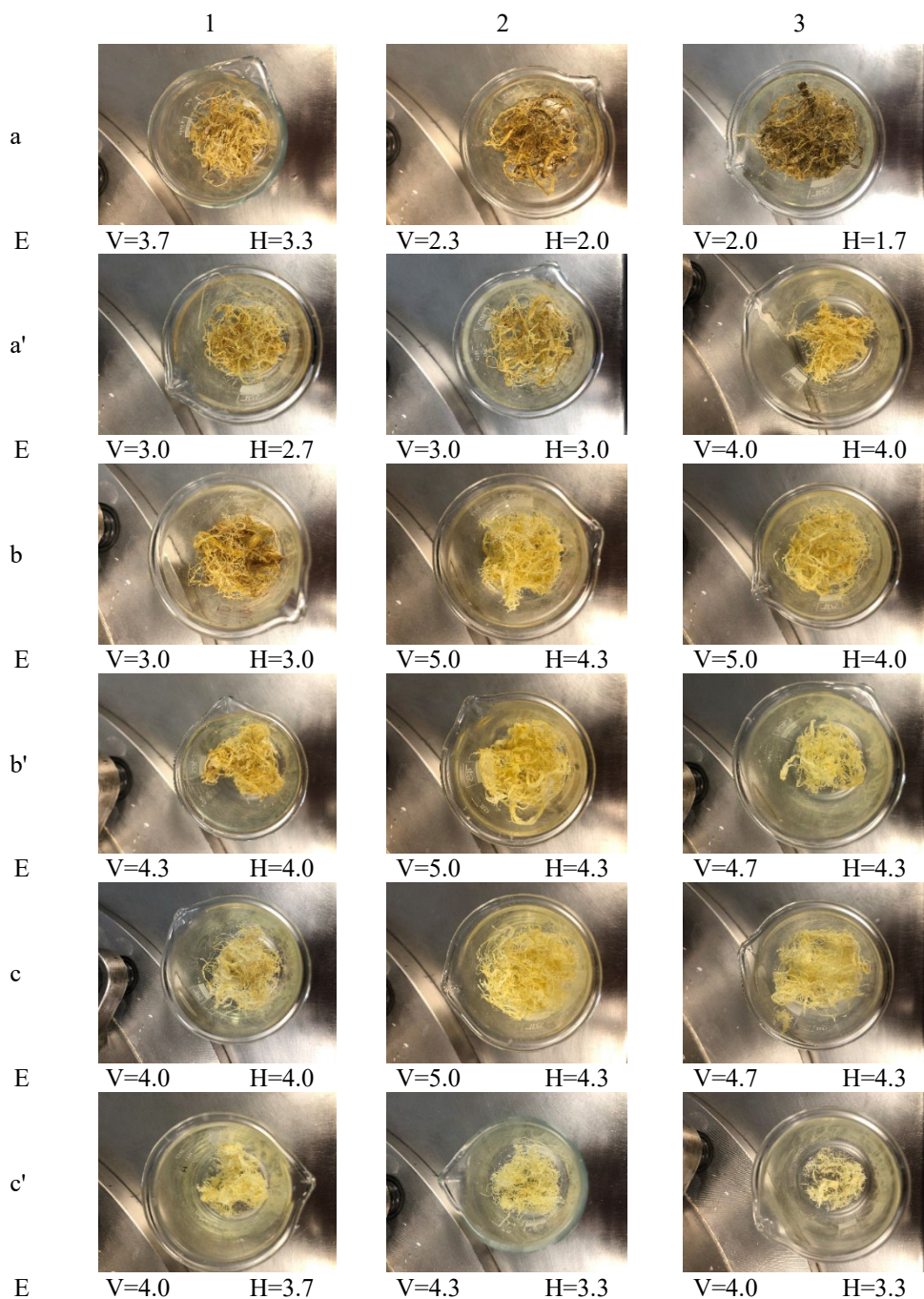
First method was subjective evaluation based on the visual and handle perception of obtained fibres and the results are presented in Table 2.

The subjective evaluation shows that samples treated with 8% and 10% H<sub>2</sub>O<sub>2</sub> at the temperature of 70 °C for a 45 to 60-minute period show the best results as well as sample c which is treated at a higher temperature - 90 °C with a shorter time period of 45 minutes.

Second method was microscopic analysis of fibres morphology along with measurement of fibres dimension (fibre's width). Results are presented in Tables 2-5.

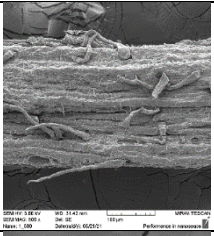
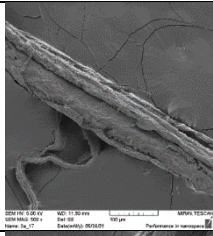
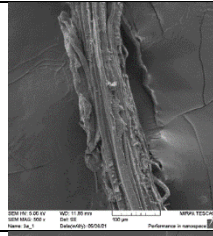
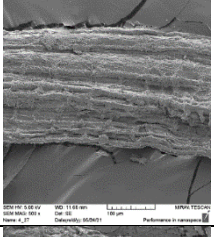
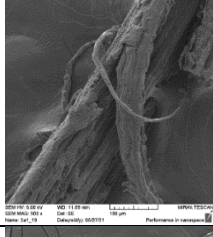
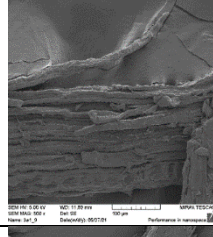
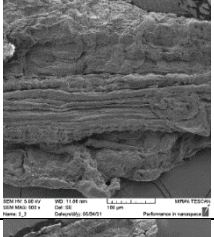
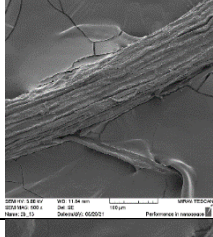
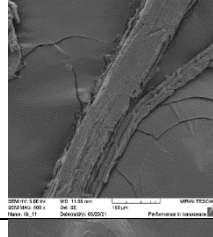
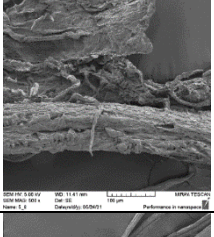
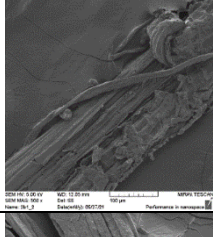
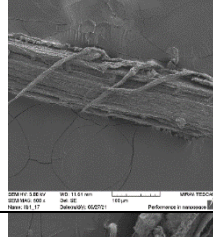
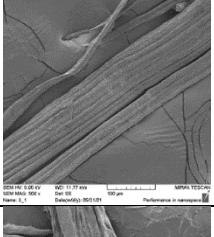

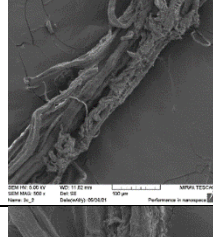
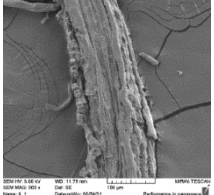
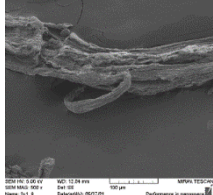
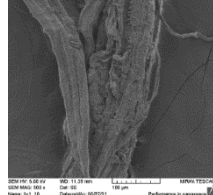
Fibre morphology analysis revealed that corn fibres are in the form of a technical fibre consisting of several dozen elementary fibres. Fibres are still partially covered with complex organic polymers - lignin and hemicellulose that indicates the need for additional experiments with the aim of complete removal of unwanted components.

The lowest concentration of H<sub>2</sub>O<sub>2</sub> applied in corn husk fibre extraction (first column in Table 2) shows obtaining of technical fibre consisted of elementary fibres which are firmly stucked together and its separation can be difficult.



**Figure 2** Subjective evaluation of corn fibres, where: E stands for evaluation, V for visual assessment and H for handle assessment.

**Table 2** SEM micrographs of obtained corn fibres

	1	2	3
a			
a'			
b			
b'			
c			
c'			

Tables 3-5 show that elementary fibres have an indication of an increase in their width while increasing processing parameters such as hydrogen peroxide concentration, temperature, and time. Such a conclusion should be supported with an extremely larger number of parallel measurements, considering that natural fibres due to their non-uniformity require much more measurements.

**Table 3** Fibres width after treatment with 5% H<sub>2</sub>O<sub>2</sub>

	d [ $\mu\text{m}$ ]					
	1a	1b	1c	1a'	1b'	1c'
<b>5% H<sub>2</sub>O<sub>2</sub></b>	9.61	17.42	13.29	26.46	17.55	21.31
	11.66	12.49	12.56	13.36	18.52	22.69
	13.80	11.02	13.98	10.61	15.99	11.57
	16.87	10.89	12.85	12.78	17.89	22.3
	13.97	11.35	14.00	11.44	19.04	19.67
<b>Average [<math>\mu\text{m}</math>]</b>	<b>13.18</b>	<b>12.63</b>	<b>13.33</b>	<b>14.93</b>	<b>17.80</b>	<b>19.51</b>
<b>Stdev [<math>\mu\text{m}</math>]</b>	2.72	2.75	0.65	6.54	1.16	4.59
<b>C [%]</b>	20.67	21.76	4.89	43.78	6.53	23.52

**Table 4** Fibres width after treatment with 8% H<sub>2</sub>O<sub>2</sub>

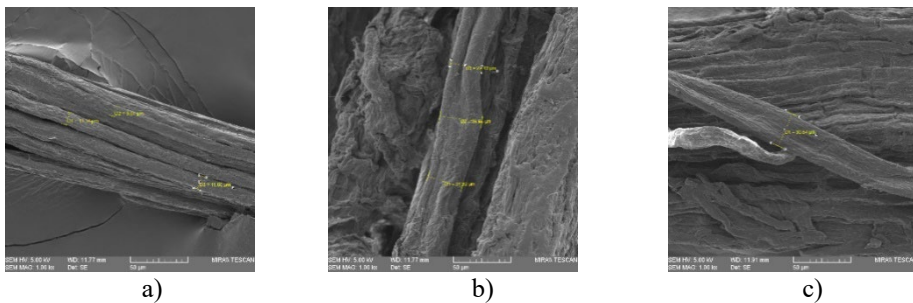
	d [ $\mu\text{m}$ ]					
	2a	2b	2c	2a'	2b'	2c'
<b>8% H<sub>2</sub>O<sub>2</sub></b>	20.53	16.68	26.18	16.35	13.57	18.49
	17.38	13.32	15.5	14.21	17.89	15.84
	14.77	16.24	23.58	17.76	15.79	23.75
	13.92	13.39	28.15	18.69	11.5	24.58
	22.82	22.32	26.71	19.93	19.54	18.56
<b>Average [<math>\mu\text{m}</math>]</b>	<b>17.88</b>	<b>16.39</b>	<b>24.02</b>	<b>17.39</b>	<b>15.66</b>	<b>20.24</b>
<b>Stdev [<math>\mu\text{m}</math>]</b>	3.78	3.66	5.04	2.21	3.23	3.76
<b>C [%]</b>	21.11	22.35	20.99	12.69	20.63	18.55

Changes in the transverse dimension of the fibres presented in Figure 3 are the result of different stages of cottonization of the technical fibre and obtaining the elementary fibre in its full form and purity. In contrast to the technical fibres, the width of the elementary fibre can be masked by its internal binders (pectin, lignin and hemicellulose).



**Table 5** Fibres width after treatment with 10% H<sub>2</sub>O<sub>2</sub>

	d [μm]					
	3a	3b	3c	3a'	3b'	3c'
<b>10% H<sub>2</sub>O<sub>2</sub></b>	13.84	12.60	16.27	21.23	8.63	22.39
	12.70	17.56	25.12	22.84	32.29	14.42
	25.67	16.79	22.21	21.10	9.87	24.12
	17.05	15.24	11.64	11.26	28.58	16.55
	19.30	23.12	18.82	16.36	10.20	16.93
<b>Average [μm]</b>	<b>17.71</b>	<b>17.06</b>	<b>18.81</b>	<b>18.56</b>	<b>17.91</b>	<b>18.88</b>
<b>Stdev [μm]</b>	5.16	3.88	5.23	4.74	11.52	4.15
<b>C [%]</b>	29.12	22.75	27.78	25.56	64.31	21.98

**Figure 3** Corn husk fibre while in the form of: a) technical fibre; b) partially cottonized technical fibre; c) elementary fibre

## CONCLUSIONS

Complete utilization of a corn crop can be considered as one of the ways to satisfy the basic principles of the circular economy – eliminating waste and pollution, circulating products and materials at their highest value and regenerating nature. Since corn is primarily used in the food industry, a large part of the waste after harvesting the mature ears refers to husk, which can be used for fibres production. Corn husk fibres extracted from the by-product of a food crop are highly available and relatively cheap. Considering all the process parameters used in this work, it can be concluded that the more suitable results were achieved with 8-10% hydrogen peroxide treatment at 70 °C for 45-60 minutes. Extracted fibres show rough surface as any other ligno-cellulosic fibres, which makes it suitable for additional chemical modifications in order to use it for technical applications i.e. as reinforcements in the production of composite materials. Our future research will include extraction of fibres from the corn stem. In this way, respecting the principles of the circular economy, the waste

of one industry (e.g. food industry) becomes the valuable input material for another industry (e.g. production of biofuels or fibre reinforced composites).

### ACKNOWLEDGEMENTS

The research has received funding from the European Regional Development Fund via KK.05.1.1.02.0016 project "Production of food, biocomposites and biofuels from cereals in a circular economy", <https://projekt-klima.eu/>.

### REFERENCES

- Bajpai, P. (2021). *Nonwood Plant Fibers for Pulp and Paper*. Elsevier, Amsterdam.
- Cheșcă, A.M., Tofănică, B.M., Cătălin Puițel, A., Nicu, R., Gavrilesco, D. (2018). Environmentally friendly cellulosic fibers from corn stalks. *Environ Eng Manag J* 17, 1765-1771.
- Daud, Z., Mohd Hatta, M.Z., Mohd Kassim, A.S., Awang, H., Mohd Aripin, A. (2013). Analysis the Chemical Composition and Fiber Morphology Structure of Corn Stalk. *Aust J Basic & Appl Sci* 7, 401-405.
- Jain, A., Rastogi, D., Chanana, B., Parmar, M.S., Dhama, A. (2017). Extraction of Cornhusk Fibres for Textile Usages, *J Polymer Text Eng* 4, 29-34.
- Jain, A., Rastogi, D., Chanana, B. (2018). Utilization of Cornhusk for Textile Usages, *J Basic Appl Eng Res* 5, 405-408.
- Kambli, N., Basak, S., Samanta, K K., Deshmukh, R R. (2016). Extraction of Natural Cellulosic Fibers from Cornhusk and Its Physico-Chemical Properties. *Fibers Polym* 17, 687-694.
- Milind, P., Isha, D. (2013). Zea Maize: A modern craze. *Int Res J Pharm* 4, 39-43.
- Peran, J., Vujasinović, E. (2018). Biorazgradiva i održiva vlakna, *Tekstil* 67, 258-278.
- Sarker Ratna, A., Ghosh, A., Mukhopadhyay, S. (2022). Advances and prospects of corn husk as a sustainable material in composites and other technical applications. *J Clean Prod* 371, 133563.
- Zheng, M., Zhang, K., Zhang, J., Zhu, LL., Du, G., Zheng, R. (2022). Cheap, high Yield, and strong corn husk-based textile bio-fibers with low carbon footprint via green alkali retting-splicing-twisting strategy. *Ind Crops Prod* 188, 115699.



## PROCESSING AND UTILIZATION OF LARGE-STEMMED HERBACEOUS PLANTS FOR ENERGY CONVERSION

Algirdas JASINSKAS<sup>1\*</sup>, Rita PETLICKAITĖ<sup>2</sup>, Edvardas VAICIUKEVIČIUS<sup>1</sup>,  
Kęstutis ROMANECKAS<sup>3</sup>

\*E-mail of corresponding author: algirdas.jasinskas@vdu.lt

<sup>1</sup> Department of Agricultural Engineering and Safety, Faculty of Engineering, Agriculture Academy, Vytautas Magnus University, Studentu str. 15A, Akademija, LT-53362 Kaunas reg., Lithuania

<sup>2</sup> Laboratory of Heat Equipment Research and Testing, Lithuanian Energy Institute, Breslaujos str. 3, LT-44403 Kaunas, Lithuania

<sup>3</sup> Department of Agroecosystems and Soil Sciences, Agronomy Faculty, Agriculture Academy, Vytautas Magnus University, Studentu str. 11, Akademija, LT 56361, Kaunas reg., Lithuania

### ABSTRACT

*The present article focuses on evaluation of the suitability of large-stemmed plants that can be grown individually and as multi-crop plants, and their biomass can be produced and used for energy conversion. The methods of plant biomass conversion to energy were reviewed and analyzed, the most popular method production of pressed solid biofuels and their burning were used for research investigations. To this purpose, three species of plants were investigated: maize, field bean and fiber hemp, which were grown separately as individual plants (3 samples) and as trinomial plants (1 sample). The object of this research was the biomass of three grown and harvested single-crop plants, and one of trinomial plants which were grown in one area. After harvesting from 4 plots and drying, plant biomass was chopped and milled, and later pressed to cylindrical 6 mm diameter pellets which were produced using a granulator of low power (120–150 kg h<sup>-1</sup>). The fractional composition of the mill in all four samples was determined: 60–90% of mill particle size were less than 2.0 mm. The length of the produced pellets ranged from 24 to 27 mm, and the diameter was sufficiently stable and varied from 6.0 to 6.2 mm. The density of pellets (moisture content 8–9%) reached 1100–1180 kg m<sup>-3</sup>. Determined lower calorific value of pellets varied from 16.9 MJ kg<sup>-1</sup> to 17.1 MJ kg<sup>-1</sup>. Harmful gas emissions during burning of the tested biofuel pellets did not exceed the allowed values. Finally, it can be stated that all investigated granules meet the most important requirements for the quality of biofuel, and it*

*can be prepared and used for energy conversion, for burning in special boilers suitable for granular biofuel.*

**Keywords:** *multi-crop plants, maize, field beans, fiber hemp, pellets, biofuel, properties, emissions.*

## INTRODUCTION

Due to the declining popularity of fossil fuels and increasing greenhouse gas emissions, according to the recent reports, renewable energy sources account for only 14% of total primary energy supply of which bioenergy accounts for 67% (Sarker *et al.*, 2022). As the demand for pellets increases, so does the interest in more diverse raw materials for the production of biomass pellets (Whittaker and Shield, 2017). Non-woody biomass, such as energy crops, agricultural waste, etc. has high energy potential and can be used as a sustainable and renewable energy source (Pradhan *et al.*, 2018). In order to produce high-quality biofuel, its densification is required (Miranda *et al.*, 2018).

Granulation is widely used to densify biomass and increase its energy potential. As the demand for pellets continues to increase, the usual raw materials used to produce pellets may not be sufficient (Jiang *et al.*, 2016).

Biofuel of the same size and shape is obtained by granulating biomass, its volumetric thermal value is increased, combustion properties are improved, emissions of solid particles are reduced, and costs for transportation and storage are reduced (Ozturk *et al.*, 2019).

In some cases, it is difficult to use biomass for the production of solid biofuel because the pellets produced do not meet the requirements of the standards for solid biofuel. In this case, the solution could be the use of biomass mixtures, thus ensuring that solid biofuel meeting the standards will be obtained. The research conducted by Hernández-Neri *et al.* (2022) showed that, for example, using only rice husk biomass for the production of pellets, the quality of the pellets is insufficient. However, biofuel pellets from mixtures of rice husks and bean straws meet the requirements of the standards.

Multi-cropping is beneficial in several ways in various aspects. When multiple crops are grown, not only the land is used more efficiently, but also soil biodiversity increases (Zhao *et al.*, 2022). The results of scientific research show that growing catch crops can effectively fight against weeds without having a negative impact on the environment (Gu *et al.*, 2021). Growing cereal crops together with legumes in one field yields a higher yield with lower costs than growing with a monocrop (Mahmoud *et al.*, 2022, Berghuijs *et al.*, 2020).

Perennial cropping as a weed control tool is suitable for no-till farming systems, as it allows reducing or eliminating the use of herbicides (D'Amico-Damião *et al.*, 2020). Studies show that growing legumes in lignocellulosic crops can provide high-quality biofuel raw material while reducing the risk of crop degradation and ensuring stable yields (Zegada-Lizarazu *et al.*, 2021).

Multi-crop plants can be grown and used successfully for biofuel production. Plants suitable for multi-annual crops can be used in various ways, one such option can be using these plants: maize, field beans and fibrous hemp. Technical and chemical aspects of fiber hemp biomass can be compared to the best plants used for energy purposes (Kraszkiwicz *et al.*, 2019). Growing hemp is good for the environment, and hemp is a good source of biofuel

(Komlajeva *et al.*, 2012). Hemp fuel properties are similar to wood and willow and superior to cereal straw, miscanthus and reed (Prade *et al.*, 2012).

The cultivation of field beans is recognized as a sustainable solution because these plants have the ability to retain atmospheric nitrogen. Also, after harvesting, a large amount of biomass, which can be used for biofuel production, remains (Gómez *et al.*, 2017).

Maize produces a large amount of biomass that is why it is widely used in the production of bioenergy. Corn is the second most popular crop in the European Union after wheat. The data show that even 85 percent maize grown in Europe is used for bioenergy production (Miedaner and Juroszek, 2021).

Analyzing these plants separately, a lot of research experiments have already been done to find out their positive properties in preparation and use for energy purposes. However, no research has been done to determine the benefits of growing them together as multi-crop plants, and to find out the advantages of processing and using them for solid biofuel. So, the objectives of this article are these mentioned multi-crop plants, and the aim of the presented research is to evaluate the possibilities of processing and utilization of large-stemmed herbaceous multi-crop plants, such as maize, field beans and fibrous hemp for bioenergy purposes.

## MATERIALS AND METHODS

The plant used for research was grown in the experimental research fields of the VMU Academy of Agriculture. Four separate fields were cultivated: corn (*Zea mays* L.), fiber hemp (*Cannabis sativa* L.), beans (*Vicia faba* L.) and fiber hemp, maize and field beans (three plants in one field). A sample of plants was taken from each field. Plants from different fields were not mixed. Biomass pellets were produced from the collected samples and their most important properties were analyzed. 4 types of pellets were obtained: Sample 1 (pellets from maize biomass), Sample 2 (biomass of fiber hemp), Sample 3 (biomass of field beans) and Sample 4 (biomass of maize, hemp and field beans grown in the same field). In order to determine the suitability of plants for biofuel, the physical-mechanical and thermal properties of biomass pellets of several crops were investigated.

Harvested plants were naturally dried to 12% humidity. A Maral 125 (Germany) drum shredder of a forage harvester was used to shred the plants. The resulting mass was ground using a Retsch SM 200 hummer mill (Germany). The fractional composition of flour was determined using a Retsch AS 200 sieve shaker (Germany). A biomass sample weighing 100 grams was sieved through sieves stacked on top of each other (starting from the top sieve) with holes of 2.0, 1.0, 0.63, 0.5, 0.25, 0.1 and mm in diameter. Each test was repeated 3 times. Pellets were produced using a low power granulator (7.5 kW) with a horizontal 6 mm matrix ZLSP200B (Poland).

The height and diameter of the granules are determined. Experimental studies of 10 pellets of each plant species were randomly selected. Length and diameter of granules were measured by using a Limit 150 mm digital Vernier caliper (PRC) (accuracy of the measurements is 0.01 mm). The samples were weighed with a KERN ABJ balance weights (Germany) to the nearest 0.01 g. Each test was repeated 3 times. Pellet volume was calculated, and then density was calculated by dividing the mass of the pellet to its volume.

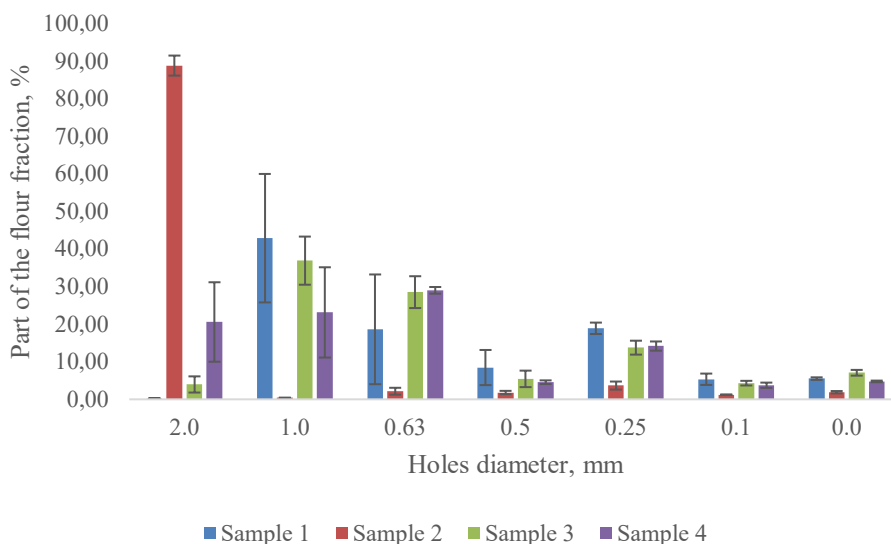
Harmful gas emissions when burning pellets were determined using a 5 kW solid fuel boiler. The prepared sample of biofuel pellets was burned for 8-10 min. Emissions of harmful gases (CO, CO<sub>2</sub>, NO<sub>x</sub> and C<sub>x</sub>H<sub>y</sub>) were measured using analyzers VE7 and Datatest 400CEM, following the standards LAND 43-2013 and LST EN 303-5: 2012.

An automatic bomb calorimeter IKA C6000 was used to determine the calorific value according to the standard LST EN 14918: 2010.

Analysis of variance of study results was performed to assess the significance of replications using F-test and LSD (95% probability level).

## RESULTS AND DISCUSSION

The size of the particles and their percentage in the biomass affect quality of the pellets. The fine particles in the biomass ensure good pellet formation during the granulation process. If there are too many fine particles, less product is produced. On the other hand, a small amount of fine particles can have a negative effect on density and durability of the granules (Tumuluru *et al.*, 2016).

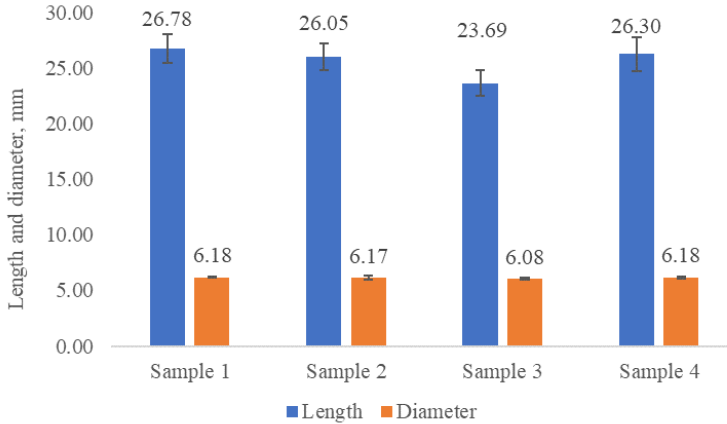


**Figure 1** Fractional composition of flour

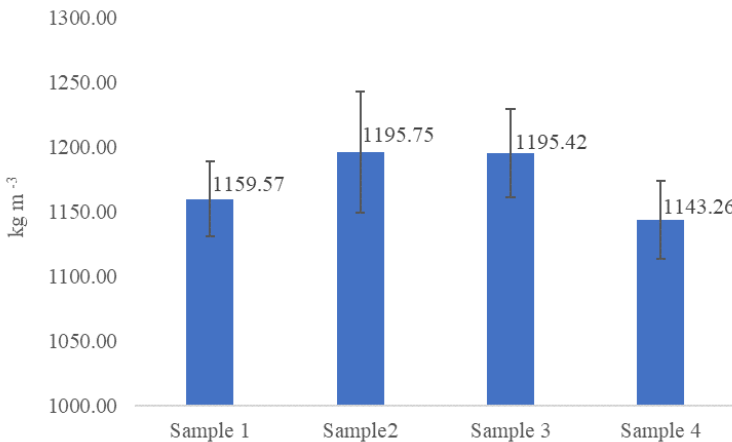
After crushing and grinding the plants, the obtained flour fraction was suitable for production of pellets. Samples 1, 3 and 4 of biomass were milled with 60 % of particles up to 1 mm size; the remaining particles were 1 or 2 mm in size. Only in Sample 2 biomass made the majority of the flour fraction (about 90%), which consisted of 1-2 mm particles (Fig. 1).

The diameter of all produced pellets was similar, about 6 mm, and the length varied from 26.1 to 26.8 mm. The length and diameter of the produced granules meet the requirements of

the ISO17225-6 standard for solid non-wood biofuels ( $3.15 \leq L \leq 40$  mm, D up to 25 mm). The parameters of a pellet made by other researchers, were very similar. According to Ozturk *et al.* (2019) the average length of granules was 17.28 mm and diameter 6.26 mm (Fig. 2).



**Figure 2** Pellet length and diameter

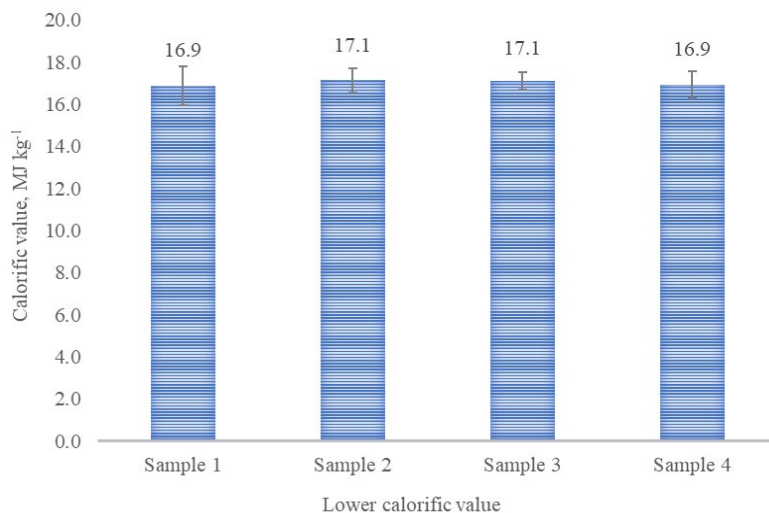


**Figure 3** The density of produced pellets (DM)

The density of the investigated pellets is presented in Fig. 3. The determined density of a produced pellet varied from 1143.26 kg m<sup>-3</sup> (Sample 4) to 1195.75 kg m<sup>-3</sup> (Sample 3). According to this parameter, all produced granules meet the requirements of the already mentioned ISO standard for class A granules. The density of pellets produced by other researchers was lower than that of our produced pellets.

Other researchers have investigated not only the density of separate pellets, but also the bulk density. Maj *et al.* (2022) found that the bulk density of pellets made from corn husks was  $610.9 \text{ kg m}^{-3}$ . The bulk density of pellets made from corn cobs was  $547.9 \text{ kg m}^{-3}$ , and that made from corn husks and corn cobs mixture was  $566.9 \text{ kg m}^{-3}$ .

Calorific value is the most important for the selection of fuel pellets. The calorific value of all the produced pellets was quite similar and reached about  $17 \text{ MJ kg}^{-1}$  (Fig. 4). The obtained data are similar to the results obtained by some other researchers.



**Figure 4** Dry fuel lower calorific value

Kusek (2018) found that the net calorific value of corn pellets was  $17.03 \text{ MJ kg}^{-1}$ . Jasinskas *et al.* (2020) found that lower calorific value of biofuel from field bean waste pellets ranged from  $16.9 \text{ MJ kg}^{-1}$  to  $17.1 \text{ MJ kg}^{-1}$ . Miranda *et al.* (2018) found that upper calorific value of corn cob wastes pellets was  $15.68 \text{ MJ kg}^{-1}$ . According to Ozturk *et al.* (2019), pellets made from corn biomass had higher calorific value –  $18.11 \text{ MJ kg}^{-1}$ . According to Maj *et al.* (2022), lower calorific value of pellets made from the corn husks and corn cobs mixture biomass was lower –  $13.09 \text{ MJ kg}^{-1}$ .

It should be noted that energy density of biomass is lower than that of solid fuel, and, in this respect, biomass fuel is less attractive to the consumer (Rajput *et al.*, 2020). Some authors suggest ways to ensure a higher lower heat of biomass pellets.

The net calorific value of pellets can be increased by adding fat or oil-based binders to the biomass. However, there is also a negative aspect as the use of such binders can increase the elasticity of the granules and, at the same time, reduce their durability (Whittaker and Shield, 2017).

Harmful emissions during the burning of pellets are also a very important parameter that characterizes their suitability for use. The equipment used for the study of harmful emissions (5 kW stove) can be seen in Figure 5.





**Figure 5** Pellet combustion test and determination of harmful gas emissions

The results of the study of harmful emissions when burning the pellets of all 4 samples can be seen in Table 1. It should be noted that the lowest CO<sub>2</sub> emissions (4.3%) were determined by burning the biomass pellets of the multi-crop plants (Sample 4). The lowest CO, NO<sub>x</sub> and C<sub>x</sub>H<sub>y</sub> emissions were determined when burning pellets of Sample 3 (109, 118 and 10 ppm respectively). To sum it all up, it can be concluded that harmful gas emissions during the burning of all sample pellets did not exceed the maximum permissible requirements.

**Table 1** Harmful emissions by burning pellets

Pellet sample	CO <sub>2</sub> %	CO ppm	NO <sub>x</sub> ppm	C <sub>x</sub> H <sub>y</sub> ppm
Sample 1	5.0	525	167	19
Sample 2	5.3	328	140	17
Sample 3	4.9	109	118	10
Sample 4	4.3	362	159	17

CO and CO<sub>2</sub> emissions determined by Bala-Litwiniak and Musiał (2022) during the burning of corn straw pellets were higher. CO emissions varied from 590 to 626 ppm and CO<sub>2</sub> emissions were 10.4%. According to Ozturk *et al.* (2019), the CO<sub>2</sub>, NO and NO<sub>x</sub> emission values of pellets from corn stalks were 4.7 ppm, 38 ppm and 40 ppm, respectively.

A study by other authors (Jasinskas *et al.*, 2020) suggested that CO<sub>2</sub> emissions when burning field bean pellets varied from 4.1 to 5.0%, CO emissions varied from 1072 ppm to 2785 ppm, NO<sub>x</sub> emissions varied from 133 ppm to 266 ppm.

Barmina *et al.* (2016) found that emissions issued when burning wheat straw pellets was: CO<sub>2</sub> – 11.94%, CO – 250 ppm, NO<sub>x</sub> – 250.7 ppm. Studies by other authors show that the use of different biomass mixtures or fuel blending can reduce harmful emissions. Dragutinović *et al.* found out that using 50% of wood and 50% of corn cob pellets can reduce total CO emissions by 48 to 60% and by 64 to 89%, respectively, compared to emissions using only corn cob pellets.

All the determined harmful gases emissions when burning these investigated pellets were in the allowed values, and this biofuel can be used together with wood and other plant pellets for heat production.

## CONCLUSIONS

During the research, pellets were produced from 4 types of biomass raw materials (fibrous hemp, maize and field beans) grown individually and as multi-crop plants, the length, diameter, density and lower calorific value of which meet the requirements of the standard ISO 17225-6. All pellets were about 6 mm in diameter and varied in length from 26.1 to 26.8 mm. The density of the produced pellets exceeded 1100 kg m<sup>-3</sup>. The lower calorific value of the pellets varied from 16.9 to 17.1 MJ kg<sup>-1</sup>. The lowest harmful CO<sub>2</sub> emissions (4.3%) were found by burning the pellets of the multi-crop plants (Sample 4). The lowest CO, NO<sub>x</sub> and C<sub>x</sub>H<sub>y</sub> emissions were determined when burning field beans biomass (Sample 3) pellets, 109, 18 and 10 ppm respectively. The determined values of harmful gas emissions did not exceed the permissible values and ensured their ability and suitability for energy use.

## REFERENCES

- Bala-Litwiniak, A., Musiał, D. (2022). Computational and Experimental Studies of Selected Types of Biomass Combustion in a Domestic Boiler. *Materials* 15, 4826.
- Barmina, I., Valdmanis, R., Zake, M. Arshanitsa, A., Akishin, Y., Telysheva G. (2016). Combustion Characteristics of Modified Plant Biomass Pellets. *Chemical Engineering Transactions* 52, 1111-1116.
- Berghuijs, H. N. C., Wang, Z., Stomph, T. J., Weih, M., van der Werf, W. G. Vico. (2020). Identification of species traits enhancing yield in wheat-faba bean intercropping: development and sensitivity analysis of a minimalist mixture model. *Agriculture, Ecosystems and Environment* 322, 107658.
- D'Amico-Damião, V., Barroso, A.A. M., da Costa Aguiar Alves, P.L., Lemos, L. B. (2020). Intercropping maize and succession crops alters the weed community in common bean under no-tillage. *Pesquisa Agropecuária Tropical* 50, e65244.
- Dragutinović, N., Höfer, I., Kaltschmitt, M. (2021). Fuel Improvement Measures for Particulate Matter Emission Reduction during Corn Cob Combustion. *Energies* 14, 4548.

- Gómez, L.D., Amalfitano, C., Andolfi, A., Simister, R. Somma, S. Ercolano, M. R., Borrelli, C. McQueen-Mason, S.J. Frusciante, L., Cuciniello, A., Caruso, G. (2017). Valorising faba bean residual biomass: Effect of farming system and planting time on the potential for biofuel production. *Biomass and Bioenergy* 107, 227–232.
- Gu, C., Bastiaans, L., Anten, Niels P.R., Makowski, D., van der Werf, W. (2021). Annual intercropping suppresses weeds: A meta-analysis. *Agriculture, Ecosystems and Environment* 322, 107658.
- Hernández-Neri, N., Gutiérrez-Antonio, C., García-Trejo, J.F., Feregrino-Pérez, A.A., Toledano-Ayala, M. (2022). Valorisation of rice husks and bean straws through fuel pellets production: an experimental and modelling approach. *Revista Mexicana de Ingeniería Química* 21, 22679.
- International standard ISO 17225-6 Solid biofuels — Fuel specifications and classes —Part 6: Graded non-woody pellets.
- Jasinskas, A., Minajeva A., Šarauskis, E., Romaneckas, K., Kimbirauskienė, R., Pedišius, N. (2020). Recycling and utilisation of faba bean harvesting and threshing waste for bioenergy. *Renewable Energy* 162, 257-266.
- Jiang, L., Yuan, X., Xiao, Z. Liang, J. Li, H. Cao, L. Wang, H., Chen, X. Zeng, G. (2016). A comparative study of biomass pellet and biomass-sludge mixed pellet: Energy input and pellet properties *Energy Conversion and Management* 126, 509–515.
- Komlajeva, L., Adamovics, A., Poisa, L. (2012). Comparison of different energy crops for solid fuel production in Latvia. *Renewable Energy and Energy Efficiency*, 45-50.
- Kraszkiewicz, A., Kachel, M., Parafiniuk, S., Zając, G. Niedziółka, I. Sprawka, M. (2019). Assessment of the Possibility of Using Hemp Biomass (*Cannabis Sativa L.*) for Energy Purposes: A Case Study. *Appl. Sci.* 9, 4437.
- Kusek, G. (2018). Determination and comparison of thermochemical characteristics of biopellets produced from corn and cotton wastes. *Fresenius Environmental Bulletin* 27 (11), 7278-7290.
- Mahmoud, R., Casadebaig, P. Hilgert N., Alletto, L., Freschet, G.T., de Mazancourt, C., Gaudio, N. (2022). Species choice and N fertilization influence yield gains through complementarity and selection effects in cereal-legume intercrops. *Agronomy for Sustainable Development* 42, 12.
- Maj, G., Krzaczek, P., Gołębiowski, W., Słowik, T., Szyszlak-Bargłowicz, J., Zając, G. (2022). Energy Consumption and Quality of Pellets Made of Waste from Corn Grain Drying Process. *Sustainability* 14, 8129.
- Miedaner, T., Juroszek, P. (2021). Global warming and increasing maize cultivation demand comprehensive efforts in disease and insect resistance breeding in north-western Europe. *Plant Pathol.* 70, 1032–1046.
- Miranda, M.T., Sepúlveda, F.J., Arranz, J.I., Montero, I., Rojas, C.V. (2018). Analysis of pelletizing from corn cob waste. *Journal of Environmental Management* 228, 303–311.
- Ozturk, H.H., Ayhan, B., Turgut, K. (2019). An assessment of the energetic properties of fuel pellets made by agricultural wastes. *Scientific Papers. Series E. Land Reclamation, Earth Observation and Surveying, Environmental Engineering* 8, 9-16.
- Prade, T. Finell, M., Svensson, S.E., Mattsson J.E. (2012). Effect of harvest date on combustion related fuel properties of industrial hemp (*Cannabis sativa L.*). *Fuel* 102, 592–604.
- Pradhan, P., Mahajani, S.M., Arora, A. (2018). Production and utilization of fuel pellets from biomass: A review. *Fuel Processing Technology* 181, 215–232.
- Rajput, S.P., Jadhav, S.V., Thorat B.N. (2020). Methods to improve properties of fuel pellets obtained from different biomass sources: Effect of biomass blends and binders. *Fuel Processing Technology* 199, 106255.

- Tumpa, R. S., Nanda, S., Meda, V., Dalai, A.K. (2022). Densification of waste biomass for manufacturing solid biofuel pellets: a review. *Environmental Chemistry Letters*. *Environ Chem Lett* (2022). <https://doi-org.ezproxy.vdu.lt:2443/10.1007/s10311-022-01510-0>.
- Tumuluru, J.S., Conner, C.C., Hoover, A.N. (2016). Method to Produce Durable Pellets at Lower Energy Consumption Using High Moisture Corn Stover and a Corn Starch Binder in a Flat Die Pellet Mill. *Journal of Visualized Experiments* 112.
- Whittaker, C., Shield, I. (2017). Factors affecting wood, energy grass and straw pellet durability – A review. *Renewable and Sustainable Energy Reviews* 71, 1–11.
- Zegada-Lizarazu, W., Parenti, A. Monti, A. (2021). Intercropping grasses and legumes can contribute to the development of advanced biofuels. *Biomass and Bioenergy* 149, 106086.
- Zhao, X., Dong, Q., Han, Y. Zhang, K., Shi, X., Yang, X. Yuan, Y., Zhou, D., Wang, K., Wang, X., Jiang, C., Liu, X. Zhang, H., Zhang, Z., Yu, H. (2022) Maize/peanut intercropping improves nutrient uptake of side-row maize and system microbial community diversity. *BMC Microbiology* 22, 14.



## ENZYMES FOR LIGNOCELLULOSIC BIOMASS DEGRADATION AS AN APPROACH TO GREEN TECHNOLOGY

Anamarija GUDELJ – VELAGA<sup>1\*</sup>, Nikola BILANDŽIJA<sup>1</sup>, Mateja GRUBOR<sup>1</sup>,  
Ivana TOMIĆ<sup>1</sup>, Zorana KOVAČEVIĆ<sup>2</sup>, Tajana KRIČKA<sup>1</sup>

\*E-mail corresponding author: [agvelaga@agr.hr](mailto:agvelaga@agr.hr)

<sup>1</sup>Faculty of Agriculture University of Zagreb, Svetošimunska cesta 25, Zagreb 10 000

<sup>2</sup>Faculty of Textile Technology University of Zagreb, Prilaz Baruna Filipovića 28a, Zagreb 10 000

### ABSTRACT

*Enzyme technology is an interdisciplinary field because its application varies from industrial purposes to pharmaceutical development, and its use is recognized as good sustainable development practice. Enzymes use in industry is preferred over other chemicals because of their selectivity, efficiency, mild conditions, renewable and sustainable practice and cost effectiveness in industry use. Enzyme use requires understanding of the structure of treated material, in this case - lignocellulosic biomass. Lignocellulosic biomass is renewable resource composed of cellulose, hemicellulose, and lignin with a diverse possibility of exploitation. These three components influence characteristics, strength, and stiffness of lignocellulosic biomass. Enzymes for cellulose degradation are: cellulases, hemicellulases, xylanases and pectinases. Enzymes for hemicellulose degradation are hemicellulases that can be xylanases or arabinofuranosidases. Enzymes for lignin degradation are lignin peroxidases, manganese peroxidases, and laccases. All these enzymes work by principle of breaking down the bonds between structural composition or other cell wall components. Use of enzymes is cost saving and an environmentally friendly alternative.*

**Keywords:** *enzymes, lignocellulosic biomass, degradation, sustainable development*

### INTRODUCTION

Plant biomass is an excellent source of energy, fibre and bio-chemicals. The use of biomass can significantly reduce dependence on fossil sources and represents a key resource for achieving sustainable development that replaces the oil-based production system and

reduces greenhouse gas emissions (Xu et al., 2013; Gonzalo et al., 2016; Kaminura et al., 2019). The structure of biomass consists mostly of lignin, cellulose and hemicellulose and is called lignocellulosic biomass (de Gonzalo et al., 2016). Lignocellulose is a macromolecular complex consisting of cellulose, hemicellulose, and lignin (Feng et al., 2011). In order to extract fibers and residues for biofuel production, there are various pretreatment methods used for biomass processing. Pretreatments are divided into physical, chemical, physico-chemical and biological. Physical pretreatment includes grinding, microwaving, extrusion, and ultrasonication. Chemical pretreatments include alkaline and acid hydrolysis, liquid ion process, and deep eutectic solvents. Physico-chemical pretreatment processes rely on steam explosion, fiber explosion with ammonia, CO<sub>2</sub> explosion, and liquid hot treatment. Biological pretreatments include the processing of whole cells and the most interesting is enzyme pretreatment (Baruah et al., 2018). The use of enzyme technologies is becoming more and more attractive for the processing of natural fibers. The main reason for the acceptance and use of enzyme technology is the fact that the application of enzymes is environmentally friendly and has a focused performance (Bledzki et al., 2010; Hanana et al., 2015). Enzymes were first used in the production of animal feed in the 1920s. In the 1970s and 1980s, researchers began to develop enzymes specifically for use in agriculture, and these enzymes were used to improve the efficiency of various agricultural processes, such as silage fermentation, the production of biofuels, and the breakdown of plant fibers (Hartmann, 2007; Pariza et al., 2010). The aim of the paper is to review the literature on the influence of enzymes on the degradation of lignocellulosic biomass and their application.

## **STRUCTURAL COMPOSITION OF LIGNOCELLULOSIC BIOMASS**

Lignocellulosic biomass is an attractive feedstock because of its variety. Biomass is widely available and can be collected from a variety of sources, including agricultural residues, forestry residues, and energy crops (Easterly and Burnham, 1996). Lignocellulosic biomass is a renewable resource that can be replenished through sustainable land management practices, and because it is composed of cellulose, hemicellulose, and lignin, which are all rich in energy and can be converted into a variety of products (Banu et al., 2021). Therefore, biomass has high energy content and can be used to produce biofuels such as ethanol, biodiesel, and biogas. In addition to being used for biofuels, biomass can also be used for production of chemicals, fibres and all kind of different materials. With a diverse possibility of exploitation of lignocellulosic biomass can help to reduce greenhouse gas emissions and promote the transition to a more sustainable, low-carbon economy (Fatma et al., 2018; Mussatto et al., 2021; Zhu et al., 2022).

The use of enzymes requires knowledge of the structure of lignocellulosic biomass. The main component is the plant cell wall, which serves as protection against external influences and enables the establishment of turgor pressure. Plant cell wall consists of cellulose, hemicellulose and lignin. Cellulose and hemicellulose are polysaccharides, while lignin is a complex phenolic polymer. These three components form the structural matrix of lignocellulosic biomass, and influence its characteristics, strength and stiffness (Giddings et al., 1980; Hernandez-Blanco et al., 2007; Xu et al., 2013).

Cellulose is one of the most important components of the plant cell and its most common applications are in the textile and paper industry. The molecular formula of cellulose is C<sub>6</sub>H<sub>10</sub>O<sub>5</sub>, and it consists of hundreds of glucose molecules connected by covalent bonds,

hydrogen bonds and van der Waals forces. It is the most abundant organic polymer on Earth and major source of energy for many organisms. Four different types of cellulose I, II, III and IV can be distinguished (Kraessig, 1993; Gutiérrez et al., 2009; Xu et al., 2013; Grubor, 2021).

Hemicellulose is also a polysaccharide with a more complex structure and bonds, its molecular formula is  $C_6H_{10}O_5$ . Hemicellulose is connected by cellulose microfibrils without covalent bonds and consists of several monosaccharides (Somerville et al., 2004; Xu et al., 2013). Depending on the type of biomass, it may contain pentoses (xylose, arabinose), hexoses (mannose, glucose, galactose) and acetyl sugars (Saha, 2003; Agbor et al., 2011). The share of hemicellulose in most plant species is 25%. Its main role is to provide a link between cellulose and lignin (Thomsen et al., 2005; Jurišić, 2012; Grubor, 2021).

Lignin is a stiffening material (like a glue) usually found between cellulose microfibrils. Because lignin is a complex polymer the exact composition of lignin can vary depending on the source. It is a complex mixture of monomers that are chemically linked together in various ways, therefore molecular formula of lignin is not a single fixed formula (Dashtban et al., 2010; Chung and Washburn, 2013). Lignin is insoluble in most solvents due to its high molecular weight and therefore represents an obstacle in the use of lignocellulosic biomass (Agbor et al., 2011; Kaminura et al., 2019; Grubor, 2021). It is responsible for providing structural support and protection, and because it is difficult to break down it can interfere with the breakdown of cellulose and hemicellulose that are the main sources of sugar for biofuel production (Weng and Chapple, 2010).

## ENZYMES

Enzymes are proteins that serve as catalysts for chemical reactions (van Beilen et al., 2002). Enzyme technology is an interdisciplinary field, recognized as an integral part of sustainable industrial development. Its applications span from straightforward industrial processes to pharmaceutical discovery and development, offering cost-effective, clean, enzymatic, or biological alternatives to traditional chemical procedures which can promote technological advancements (Godfrey and West, 1996; Kirst et al., 2001). With the potential to transform agricultural waste biomass into a valuable resource to produce chemicals and fuels, biobased renewables offer many advantages, such as reduced CO<sub>2</sub> production, flexibility, and self-reliance. The Royal Dutch/Shell group predicted that by the year 2050, renewable resources could potentially supply up to 30% of the global chemical and fuel needs, resulting in a biomass market of \$150 billion. This information is vital to scientists and other professionals in the field of enzyme technology, as it provides insight into the potential of biobased renewables and the possibilities for sustainable industrial development (OECD, 1998; Novozymes, 2002; van Beilen et al., 2002).

### *Enzymes for cellulose degradation*

There are several types of enzymes that can be used to break down cellulose for different production purposes, including cellulases and hemicellulases. Cellulases are enzymes that break down cellulose into glucose, while hemicellulases are enzymes that break down hemicellulose, a type of polysaccharide found in plant cell walls (Horn et al., 2012). The use of the enzyme hemicellulase increases the availability of cellulase to cellulose and enables better enzymatic hydrolysis (Zhao et al., 2018). Both types of enzymes are produced by microorganisms and can be used to hydrolyze cellulose and hemicellulose into simpler sugars

that can be fermented. Other enzymes that are used in the production of biofuels from cellulose include xylanases, which break down xylan (another type of polysaccharide found in plant cell walls), and pectinases, which break down pectin (a polysaccharide found in plant cell walls and fruit) (Dodd and Cann, 2009). These enzymes can also be used to improve the efficiency of cellulose conversion by breaking down the other plant cell wall components that may interfere with cellulose accessibility to the cellulases (Arantes and Saddler, 2010; Houfani et al., 2020).

### ***Enzymes for hemicellulose degradation***

Hemicellulose can be broken down into these simpler sugars which can then be fermented and converted into biofuels such as ethanol (Houfani et al., 2020). There are several types of hemicellulases that can be used to break down hemicellulose, including xylanases and arabinofuranosidases (which break down arabinose, sugar found in hemicellulose) (Perez et al., 2002; Saha, 2003). These enzymes work by breaking the bonds between the sugar monomers that make up hemicellulose, releasing the individual sugars and making them available for fermentation (Saha, 2003). Hemicellulases are produced by a variety of microorganisms, including bacteria and fungi, and can be used to improve the efficiency of biofuel production from plant feedstocks. In addition to their use in biofuel production, hemicellulases are also used in other industrial processes, such as the production of paper, food, and animal feed (Viikari et al., 1993; Saha 2003).

### ***Enzymes for lignin degradation***

There are several enzymes that have been identified as having the potential to break down lignin, including peroxidases (lignin peroxidases and manganese peroxidases), laccases, and proteases (Perez et al., 2002). These enzymes are produced by certain types of fungi and bacteria and are able to break down lignin by oxidizing it. Some proteases have been shown to be able to hydrolyse lignin, particularly in the presence of other enzymes such as laccases or peroxidases, but mainly protease is used to remove any residual cellulose and hemicellulose after treating lignin with other enzymes (Nakagame et al., 2011). These enzymes work together to break down the lignin polymer into smaller, more easily degradable fragments. It is important to note that the best enzymes for lignin degradation are peroxidases and laccases, and they are produced by a white rot fungi. These enzymes work by catalysing the oxidation of lignin molecules, which causes the polymer to break down into smaller, more manageable fragments (Perez et al., 2002). To make these enzymes more efficient for industrial application it is important to note that addition of activators, catalysts and optimal conditions are beneficiary to get the most out of enzymes.

## **THE INDUSTRIAL ADVANTAGE OF USING ENZYMES**

Enzymes use in industry is preferred over other chemicals because enzymes are highly specific in their catalytic activity, meaning they can perform very specific chemical reactions without affecting other molecules (Bilal et al., 2019). This allows to produce very pure and high-quality products. Enzymes can perform reactions much faster than chemical catalysts, and they often require less energy to do so. Enzymes often work under mild conditions, such as at low temperatures and neutral pH (Zhao et al., 2017). This can be especially beneficial for sensitive compounds that can be damaged by harsher conditions. Enzymes are biocatalysts, meaning that they are derived from living organisms, usually microorganisms



that can be grown and replenished (Robinson, 2015). They are not a finite resource like many chemical catalysts, making it a more sustainable option. Enzymes are often less expensive to produce than chemical catalysts, and they can be used in high concentrations. This can lead to significant cost savings for industrial processes (Perez et al., 2002).

## CONCLUSION

Enzymes are a relatively new technology with diverse applications. The influence of enzymes in the utilization of lignocellulosic biomass has a positive effect on the concept of sustainability and circular economy. It is important to know which enzymes can be used depending on the structure for which they will be used, distinguishing between the use for cellulose, hemicellulose, and lignin degradation. Overall enzymes are valuable tools for many industrial processes as they can be very effective and environmentally friendly alternative to traditional chemical catalysts.

## ACKNOWLEDGMENTS:

The research has received funding from the European Regional Development Fund via K.K.01.1.1.04.0091 project ‘‘Design of Advanced Biocomposites from Renewable Energy Sources – BIOCOMPOSITES’’

## REFERENCES

- Agbor, V. B., Cicek, N., Sparling, R., Berlin, A., Levin, D. B. (2011). Biomass pretreatment: fundamentals toward application. *Biotechnology advances*, 29(6), 675-685.
- Arantes, V., Saddler, J. N. (2010). Access to cellulose limits the efficiency of enzymatic hydrolysis: the role of amorphogenesis. *Biotechnology for biofuels*, 3(1), 1-11.
- Banu, J. R., Kavitha, S., Tyagi, V. K., Gunasekaran, M., Karthikeyan, O. P., Kumar, G. (2021). Lignocellulosic biomass based biorefinery: A successful platform towards circular bioeconomy. *Fuel*, 302, 121086.
- Baruah, J., Nath, B. K., Sharma, R., Kumar, S., Deka, R. C., Baruah, D. C., Kalita, E. (2018). Recent trends in the pretreatment of lignocellulosic biomass for value-added products. *Frontiers in Energy Research*, 6, 141.
- Bilal, M., Zhao, Y., Noreen, S., Shah, S. Z. H., Bharagava, R. N., Iqbal, H. M. (2019). Modifying biocatalytic properties of enzymes for efficient biocatalysis: A review from immobilization strategies viewpoint. *Biocatalysis and Biotransformation*, 37(3), 159-182.
- Bledzki, A. K., Mamun, A. A., Jaszkiwicz, A., Erdmann, K., (2010). Polypropylene composites with enzyme modified abaca fibre. *Composites Science and Technology*. 70, 854–60.
- Chung, H., Washburn, N. R. (2013). Chemistry of lignin-based materials. *Green materials*, 1(3), 137-160.
- Dashtban, M., Schraft, H., Syed, T. A., Qin, W. (2010). Fungal biodegradation and enzymatic modification of lignin. *International journal of biochemistry and molecular biology*, 1(1), 36.
- de Gonzalo, G., Colpa, D. I., Habib, M. H., Fraaije, M. W. (2016). Bacterial enzymes involved in lignin degradation. *Journal of biotechnology*, 236, 110-119.
- Dodd, D., Cann, I. K. (2009). Enzymatic deconstruction of xylan for biofuel production. *Gcb Bioenergy*, 1(1), 2-17.

- Easterly, J. L., Burnham, M. (1996). Overview of biomass and waste fuel resources for power production. *Biomass and Bioenergy*, 10(2-3), 79-92.
- Fatma, S., Hameed, A., Noman, M., Ahmed, T., Shahid, M., Tariq, M., Sohail, I., Tabassum, R. (2018). Lignocellulosic biomass: a sustainable bioenergy source for the future. *Protein and peptide letters*, 25(2), 148-163.
- Feng, C., Zeng, G., Huang, D., Hu, S., Zhao, M., Lai, C., Huang, C., Wei, Z., Li, N. (2011). Effect of ligninolytic enzymes on lignin degradation and carbon utilization during lignocellulosic waste composting. *Process Biochemistry*, 46(7), 1515-1520.
- Giddings, T., Brower, D., Staehelin, L. (1980). Visualization of particle complexes in the plasma membrane of *Micrasterias denticulata* associated with the formation of cellulose fibrils in primary and secondary cell walls. *The Journal of cell biology*, 84(2), 327-339.
- Godfrey, T., West, S. (1996). *Industrial Enzymology*. London: Macmillan Press Ltd.
- Grubor, M. (2021). Utjecaj sastava i mehaničke pripreme biomase na kakvoću biougljena dobivenog pirolizom (Doctoral dissertation, University of Zagreb. Faculty of Agriculture).
- Gutiérrez, A., del Río, J. C., Martínez, A. T., (2009). Microbial and enzymatic control of pitch in the pulp and paper industry. *Applied microbiology and biotechnology*, 82(6), 1005-1018.
- Hanana, S., Elloumi, A., Placet, V., Tounsi, H., Belghith, H., Bradai, C. (2015). An efficient enzymatic-based process for the extraction of high-mechanical properties alfa fibres. *Industrial Crops and Products*, 70, 190-200.
- Hartmann, T. (2007). From waste products to ecochemicals: fifty years research of plant secondary metabolism. *Phytochemistry*, 68(22-24), 2831-2846.
- Hernandez-Blanco, C., Feng, D., Hu, J., Sanchez-Vallet, A., Deslandes, L., Llorente, F., Berrocal-Lobo, M., Keller, H., Barlet, X., Sanchez-Rodriguez, C., Anderson, L. K., Somerville, S., Marco, Y., Molina, A. (2007). Impairment of cellulose synthases required for *Arabidopsis* secondary cell wall formation enhances disease resistance. *The Plant Cell*, 19(3), 890-903.
- Horn, S. J., Vaaje-Kolstad, G., Westereng, B., Eijsink, V. (2012). Novel enzymes for the degradation of cellulose. *Biotechnology for biofuels*, 5(1), 1-13.
- Houfani, A. A., Anders, N., Spiess, A. C., Baldrian, P., & Benallaoua, S. (2020). Insights from enzymatic degradation of cellulose and hemicellulose to fermentable sugars—a review. *Biomass and Bioenergy*, 134, 105481.
- Jurišić, V. (2012). Optimizacija uvjeta visokosmicajne ekstruzije trave iz roda *Miscanthus* kao sirovine za proizvodnju bioetanol. Doktorski rad. Prehrambeno - biotehnoški fakultet Sveučilišta u Zagrebu, Zagreb, Hrvatska.
- Kamimura, N., Sakamoto, S., Mitsuda, N., Masai, E., Kajita, S. (2019). Advances in microbial lignin degradation and its applications. *Current Opinion in Biotechnology*, 56, 179-186.
- Kirst, A., Yeh, W. K., Zmijewski, M. J. J. (2001). *Enzyme Technologies for Pharmaceutical and Biotechnological Applications*. New York: Marcel Dekker, Inc.
- Kraessig, H. (1993). *Cellulose: structure, accessibility, and reactivity*. CRC.
- Mussatto, S. I., Yamakawa, C. K., van der Maas, L., Dragone, G. (2021). New trends in bioprocesses for lignocellulosic biomass and CO<sub>2</sub> utilization. *Renewable and Sustainable Energy Reviews*, 152, 111620.
- Nakagame, S., Chandra, R. P., Kadla, J. F., Saddler, J. N. (2011). Enhancing the enzymatic hydrolysis of lignocellulosic biomass by increasing the carboxylic acid content of the associated lignin. *Biotechnology and bioengineering*, 108(3), 538-548.
- Novozymes AS: Annual Report 2001. Bagsvaerd, Denmark; 2002.
- OECD (1998). *Biotechnology for Clean Industrial Products and Processes*. Paris, France: OECD.

- Pariza, M. W., Cook, M. (2010). Determining the safety of enzymes used in animal feed. *Regulatory Toxicology and Pharmacology*, 56(3), 332-342.
- Pérez, J., Muñoz-Dorado, J., De la Rubia, T. D. L. R., & Martínez, J. (2002). Biodegradation and biological treatments of cellulose, hemicellulose and lignin: an overview. *International microbiology*, 5(2), 53-63.
- Robinson, P. K. (2015). *Enzymes: principles and biotechnological applications*. Essays in biochemistry, 59, 1.
- Saha, B. C. (2003). Hemicellulose bioconversion. *Journal of industrial microbiology and biotechnology*, 30(5), 279-291.
- Somerville, C., Bauer, S., Brininstool, G., Facette, M., Hamann, T., Milne, J., Osborne, E., Paredes, A., Persson, S., Raab, T., Vorwerk, S., Youngs, H. (2004). Toward a systems approach to understanding plant cell walls. *Science*, 306:2206–2211.
- Thomsen, A. B., Rasmussen, S., Bohn, V., Vad Nielsen, K., Thygesen, A. (2005). Hemp raw materials: The effect of cultivar, growth conditions and pretreatment on the chemical composition of the fibres. Risø-Report. Risø National Laboratory, Roskilde, Denmark.
- van Beilen, J. B., Li, Z. (2002). Enzyme technology: an overview. *Current opinion in biotechnology*, 13(4), 338-344.
- Viikari, L., Tenkanen, M., Buchert, J., Ratto, M., Bailey, M., Siikaaho, M., Linko, M. (1993). Hemicellulases for industrial applications. In: Saddler JN (ed) *Bioconversion of forest and agricultural plant residues*. CAB, Oxford, pp 131–182.
- Weng, J. K., Chapple, C. (2010). The origin and evolution of lignin biosynthesis. *New Phytologist*, 187(2), 273-285.
- Xu, F., Yu, J., Tesso, T., Dowell, F., Wang, D. (2013). Qualitative and quantitative analysis of lignocellulosic biomass using infrared techniques: a mini-review. *Applied energy*, 104, 801-809.
- Zhao, J., Dong, Z., Li, J., Chen, L., Bai, Y., Jia, Y., Shao, T. (2018). Ensiling as pretreatment of rice straw: The effect of hemicellulase and *Lactobacillus plantarum* on hemicellulose degradation and cellulose conversion. *Bioresource technology*, 266, 158-165.
- Zhao, X., Liu, W., Deng, Y., & Zhu, J. Y. (2017). Low-temperature microbial and direct conversion of lignocellulosic biomass to electricity: Advances and challenges. *Renewable and Sustainable Energy Reviews*, 71, 268-282.
- Zhu, X., Liu, M., Sun, Q., Ma, J., Xia, A., Huang, Y., Zhu, X., Liao, Q. (2022). Elucidation of the interaction effects of cellulose, hemicellulose and lignin during degradative solvent extraction of lignocellulosic biomass. *Fuel*, 327, 125141.

---

---



## ENERGY CONSUMPTION FOR PRODUCTION RAPESEED OIL ON FAMILY FARMS

Viktor JEJČIČ<sup>1\*</sup>, Tomaž POJE<sup>1</sup>, Fouad AL-MANSOUR<sup>2</sup>

\*E-mail of corresponding author: viktor.jejcic@kis.si

<sup>1</sup>Agricultural institute of Slovenia, Department of Agricultural Engineering and Energy,  
Hacquetova ulica 17, SI – 1000 Ljubljana, Slovenia,

<sup>2</sup>Josef Stefan Institute, Energy Efficiency Centre, Jamova cesta 39, SI – 1000 Ljubljana, Slovenia

### ABSTRACT

*Vegetable oils obtained from various oilseeds are used for food, pharmaceuticals and different technical purposes. In healthy diets it is also very important to use vegetable oils, which are produced in an environmentally friendly way. In decentralized production, farms can produce high-quality cold-pressed oils from oilseeds, such as sunflower, oilseed rape, etc. Due to the possibility of achieving higher added value on farms and the relative availability of technology for own production of vegetable oils from oilseeds, an energy analysis of decentralized oil production was made. Direct energy consumption of rapeseed production in Slovenia has been determined by farm production methods (conventional and organic). Energy consumption is estimated for the case of rapeseed production, internal transport, drying, and rapeseed processing in oil. Total energy use of the final product rapeseed oil is presented as the sum of all energies used from rapeseed production and processing it to final product – rapeseed oil. For conventional rapeseed production total direct energy consumption for rapeseed oil production is 4278.6 MJ t<sup>-1</sup> oil and for organic rapeseed production 3853.8 MJ t<sup>-1</sup> oil.*

**Keywords:** rape seed production, conventional production, organic production, direct energy, rape seed oil, energy consumption MJ t<sup>-1</sup> oil

### INTRODUCTION

Vegetable oils obtained from seeds of various oilseed crops are used today for food, pharmaceuticals, technical use and for fuel production (biodiesel of first and second generation) or for direct use on burners, modified diesel engines, micro turbines, etc. The mechanical extraction of vegetable oils from oilseeds, used by mankind over the centuries, has been nearly completely replaced in the world with the industrial production of oils after WW II. In the last few decades, vegetable oils produced by the mechanical extraction process

have become increasingly established due to their properties, which are especially valued in human nutrition and pharmacy. Vegetable oils, obtained exclusively by mechanical extraction, contain many different nutrients, which are almost completely preserved during the process of mechanical compression of the seed.

The use of vegetable oils, produced in an environmentally friendly way (from organically grown plants - oilseeds to the final product, cold-pressed oil), is hence gaining ground in a healthy diet. Therefore, in recent years, the process of cold pressing oil, which was very well known in the past, is returning to wider use. Due to the possibility of achieving higher added value on farms and the relative availability of technology for own production of oils from oilseeds (cold pressed oils are classified in a higher quality products), an energy analysis of decentralized oil production and consequently its carbon footprint was made. In decentralized production, farms can produce high-quality cold-pressed oils from oilseeds, such as e.g. sunflower, oilseed rape, flax, poppy, hemp, grape seeds, etc. In Slovenia vegetable oils are produced in small oil mills on family farms, small enterprises or in oil companies with industrial production. In recent years there is a rising number of oil mills with cold pressing and combined cold-hot pressing all types of oilseeds in Slovenia.

Rapeseed production on Slovenian family farms is on conventional and organic way (more and more in recent years). There are differences in farm mechanization for both ways of farming (some machines are different and some similar for both productions). In conventional way of farming for primary soil tillage, ploughing with a mounted reversible ploughs is in use. For seed bed preparation in secondary soil tillage, cultivators are in use. Seeding is done with mounted mechanic or pneumatic seeders and fertilizing with mineral fertilizers with mounted disc fertilizers. In case of organic farming primary soil tillage is with stubble cultivator (chisel type). Secondary soil tillage is combined with direct sowing with pneumatic seeders and seed bed preparation is with PTO powered harrows (both operations in one passage). For applications of organic fertilizers - slurry, distribution with slurry tankers (deposition on soil surface or in subsoil) is in use. For both productions harvesting and transport is the same. Harvesting is with grain combines and transport of grain from farm fields to farms with tractors with attached trailers.

Combustion of the different fuels generates heat for drying oilseeds. Liquid and gaseous fuels are most often used for seed drying and in the last period more and more also different biomass (wood, harvesting residues like corncobs, etc.) as solid fuel. Heating oil fuel was mostly used in the past for grain drying. Due to less air pollution and the price, natural gas pushing heating oil fuel out of use (in the recent period we have seen the prices of energy products rise tremendously so that even natural gas has a high price). Of the gaseous fuels, natural gas is mostly used in our country in grain dryers, while some grain dryers that do not have access to the natural gas network also use liquefied petroleum gas - LPG. On many Slovenian family farms, mobile grain dryers are used to dry grain. Liquid or gaseous fuels are used for drying in mentioned dryers, and in the recent period, European manufacturers have also started to offer the aforementioned versions of dryers that also run on different biomass. Transport dryers operating with the tractor PTO (use for fan drive to create an air flow, drive of grain conveyors for filling, emptying, mixing and constant circulation of grain and removal of impurities and dust). In the case of the electric driven version of mobile dryer, fan, grain conveyors and other dryer assemblies function with own electric motors. Burner of transport dryer runs on heating oil, natural gas - NG or liquefied petroleum gas - LPG. Drying on mobile dryers takes place in four stages, the first stage is the filling of the dryer with the conveyor,

the second stage is the drying of the grain, the third stage is the cooling of the grain and the last, fourth stage is the emptying of the dryer with the conveyor.

Oil production from oil seeds on industrial scale is with warm pressing, solvent extraction and refining. Processing capacity on industrial scale is up to 3000 tons of processed seeds in oil per day. Decentralised production of oils on farms is from 0,1 to 25 tons of processed oil seeds per day. Oil seeds can be processed (mechanical extraction) according to needs of farm, thereby achieving a constant production of fresh oil and animal feed (oil cake). The difference with industrial oil production is that family farms are using mainly technology of cold pressing of oil seeds and oil filtration with more simpler machines with small capacity. Some stages used in oil production on industry scale are also not present on the family farms. In the processing of oilseeds into vegetable oils, family farms and small oil enterprises use machines powered with electrical energy (machines for cleaning oil seeds, oil screw presses, oil filters, etc.). Oil screw presses with a electrical power of 1.2 kW<sub>e</sub> to 5 kW<sub>e</sub> are common on family farms due to their ease of use and maintenance, lower costs and good working performances. The output of the mini oil screw presses is 15-50 kg of pressed oilseeds/h, which depends on the type of seed, the input temperature and humidity of the seed, etc. Mini presses up to 5 kW are intended for several hours or all day use for small scale production of oil for various purposes and preparation of fodder (oil cake) for feeding animals on farms.

#### *Analysis of energy use for vegetable oil production*

In the EU, direct energy uses on farms with crops production are dominantly depending on fossil fuels (Al-Mansour and Jejcic, 2016). In the case of mechanized production, mineral diesel fuel is used for tractors with implements and self-propelled agricultural machinery. Different studies have reported, that due to different conditions in agricultural production (soil characteristics, machine type and settings, working speeds, harvest amount, plot size and form, etc.), the use of diesel fuel for various agricultural operations can vary greatly, hence it is required to consider average values as the measured values (l/ha or kg ha<sup>-1</sup>) for fuel consumption (Handler 2012; Dalgaard et al., 2001, Jejčić and Al-Mansour, 2014). Grain drying is one of the most energy-consuming processes in agriculture. Energy consumption in the drying of oilseeds depends on the construction of the dryer and the material being dried. Typical energy consumption in existing convection dryers ranges from 3.5 to 7 MJ (average consumption 4.2 MJ) for 1 kg of evaporated water (Katić, 1997). Data obtained from measurements of energy consumption on dryers in operation (for different types of grain dryers) show that energy consumption ranges from 3.2 to 6.5 MJ kg<sup>-1</sup> of evaporated water when drying corn grain from an initial moisture content of 25 % to a final moisture content of 15% (Scott, 2017). (Peltola 1985, Suomi 2005) measured the specific energy consumption of grain dryers. They found that the consumption of heating oil amounts to 103-164 g kg<sup>-1</sup> of evaporated water from the grain, which corresponds to 4.4-7.1 MJ kg<sup>-1</sup> of evaporated water (the data includes heat from fuel combustion, heat transport and the drying process itself). (Thuncke and Remmele, 2007) found out that energy consumption for oil production on industrial way is 1.7 GJ t<sup>-1</sup> seeds and on decentralised way used on farms is 0.5 to 5 GJ t<sup>-1</sup> seeds. Bogaert et al. (2018) studied oil seeds mechanical extraction in a screw press. Their results showed that increasing the rotation speed enhances the press capacity and decreases the passage time, and reduces the extraction yield and the specific energy consumption. (Chapuis et al., 2018) worked on separation efficiency and energy consumption of screw press for oil processing. They found that the specific mechanical energy for oil expression was less than 5 % of the energy content of the oil and the minimum mechanical energy requirement

was generally observed at oil recoveries between 70 and 80 %. (Mizera et al., 2018) focused on the analysis of optimization of the pressing process of rapeseeds using screw press. Oil recovery efficiency and specific mechanical energy were decreased when the seed material throughput was increased. (Özilgen and Sorgüven, 2011) in a review of research in the field of energy consumption for mechanical extraction of oilseeds find that the energy consumption for mechanical extraction of oil from sunflower seeds with a screw press with a capacity of 300 kg h<sup>-1</sup> of processed seeds, 132 MJ t<sup>-1</sup> of processed seeds.

## MATERIALS AND METHODS

### *Energy consumption in oil seed production*

Analysis of energy consumption in oil seed crops production was made for rapeseed production. In the energy analysis all intakes of direct energy are done in the production process. Inputs of indirect energy (production of farm machines as well as energy for the production of mineral fertilizers, pesticides, etc.), were not taken into account. The energy consumption is defined as the energy from diesel fuel to be used in the implementation of various mechanized operations. The total energy consumed for producing oilseed crop yield per area of one hectare, was determined by adding the energy consumption of each energy input.

$$E_{oprod} = E_{st} + E_f + E_p + E_h + E_{it} + E_d \quad (1)$$

where:

- $E_{oprod}$  = total energy used for oil seed crop production (MJ),
- $E_{st}$  = energy for primary and secondary soil tillage,
- $E_f$  = energy consumption for fertilizing oil seed crops,
- $E_p$  = energy consumption for protection oil seed crops,
- $E_h$  = energy consumption for harvesting oil seed crops,
- $E_{it}$  = energy consumption for internal transport of yield from fields to farm,
- $E_d$  = energy consumption for additional drying of oil seed crops.

For the production of rapeseed an analysis for conventional and organic farm production has been made. Energy consumption in the aforementioned production is determined in the course of working operations with the tractors with implements for primary and secondary tillage, seeding, fertilization, plant protection, etc. Determined was also energy consumption for harvesting and internal transport of oilseed crops from field to the farm (transportation by tractors).

### *Processing of oil seed crops to vegetable oils on small scale*

Before further processing of oilseeds in final products, cleaning of crops to remove impurities must be carried out. The purpose of mechanical extraction is to separate the oil part from the solid part of the seed material from the oilseeds (sunflower, oilseed rape, etc.). There is also a small amount of mechanical impurities in the oil that comes out of the press. The methods for cleaning oil from impurities on farms are very simple (oil is mechanically cleaned of impurities by means of sedimentation or filtration process or a combination of both methods):

$$E_{oproc} = E_{cle} + E_{op} + E_{of} \quad (2)$$



where

$E_{oproc}$  = total energy used in processing oil seeds into vegetable oil (MJ),

$E_{cle}$  = energy for cleaning the oil seeds from impurities,

$E_{op}$  = energy for mechanical extraction of oil seeds to vegetable oils (pressing),

$E_{of}$  = energy for filtering vegetable oils.

### **Total energy used for oil production**

Total energy used in the production of rapeseed is added to the total energy used for processing rape seed into final product – vegetable oil. The sum of the two energies is the total energy used for the final product – vegetable oil:

$$E_{finprod} = E_{oprod} + E_{oproc} \quad (3)$$

where:

$E_{finprod}$  = total energy of the final product – vegetable oil (MJ),

$E_{oprod}$  = total energy used in oil seed crops production,

$E_{oproc}$  = total energy used in processing oil seeds into vegetable oil.

## **RESULTS AND DISCUSSION**

The consumption of energy for various operations in conventional and organic rapeseed production was determined. Mineral diesel fuel consumption for tractors with implements and trailers and self propelled machines - combines is expressed in l/ha and converted in MJ ha<sup>-1</sup>. The consumption of mineral diesel fuel was measured on ten farms using the volumetric method. Model calculations are made based on the average diesel fuel consumptions. Energy consumption in the conventional farming with conventional soil tillage was determined for the soil tillage with a mounted reversible ploughs and seed bed preparation in secondary soil tillage with cultivators (two passes of the cultivators for the preparation of the seed bed). Seeding after mentioned passes of cultivators was made in one pass with mounted mechanical seed drills. For application of mineral fertilizers mounted disc fertilizers were used in two passes. The spraying has been done with mounted sprayers in two passes. For harvesting combine was used and transport of rapeseed crops was made with tractor with attached trailer. For model calculations average yield of rape seed is 3500 kg ha<sup>-1</sup> for conventional production.

In organic production some mechanized operations are performed with other machines, and in some is used the same machinery as in conventional farming (spraying of allowed pesticides, harvest and grain transport). An alternative to primary soil tillage with ploughing is soil tillage with stubble cultivator (chisel type). Secondary soil tillage (seed bed preparation with PTO powered harrows) is combined with direct sowing (pneumatic seeder) in one passage. For applications of organic fertilizers - slurry, distribution with slurry tankers was used (slurry was applied in three passes). Spraying was made with mounted sprayers in three passes. Same combine type was used for harvesting as in case of organic farming and transport of rapeseed crops was made with tractor with attached trailer. For model calculations average yield of rape seed in organic production is 3220 kg ha<sup>-1</sup> (8 % lower in comparison with conventional rape seed production).

**Table 1** Energy use in conventional farming, average results for energy consumption for different operations in rapeseed production.

<b>Operation</b>	<b>Energy use (MJ ha<sup>-1</sup>)</b>
Soil tillage with ploughing	881.02
Seedbed preparation with cultivator	756.50
Seeding	101.57
Mineral fertilizers spreading	357.00
Spraying	169.32
Harvesting	811.32
Internal tractor transport	232.81
<b>Total</b>	<b>3309.54</b>

**Table 2** Energy use in organic production, average results for energy consumption for different operations in rapeseed production.

<b>Operation</b>	<b>Energy use (MJ ha<sup>-1</sup>)</b>
Soil tillage with stubble cultivator (chisel type)	486.20
Seedbed preparation with rotary harrow and seeding (combined operations in one passage)	447.52
Slurry spreading	357.00
Spraying (with allowed pesticides)	253.98
Harvesting	811.32
Internal tractor transport	232.81
<b>Total</b>	<b>2588.83</b>

Total direct energy consumption in conventional rape seed production is higher 21.8 % in comparison with organic production of rapeseed. Energy consumption in soil tillage with ploughing is higher 44.8 % in comparison with soil tillage with stubble cultivator (chisel type). If we compare operations of separated seedbed preparation with cultivator and seeding, with seedbed preparation with rotary harrow and seeding in one passage, energy consumption is higher for conventional system with separated secondary tillage and seeding for 48.4 %.

After the production of rapeseed, the seeds are dried and coarse cleaned. Determined was the energy consumption for drying of rapeseed, when drying takes place from 14 % input moisture to 9 % final moisture of rapeseed. Mobile grain dryer operated on heating oil (dryer's burner) and electric energy (mentioned energy is relatively small, amounting to 13.7 % of the total energy for grain drying). Electric energy is intended for fan drive to create an air flow, drive of grain conveyors for filling, emptying, mixing and constant circulation of grain and removal of impurities and dust (coarse rapeseed cleaning).

**Table 3** Energy use for rapeseed drying with mobile drying unit ( $\text{MJ t}^{-1}$  seed), from initial moisture 14 % on final moisture 9 %.

	Energy use ( $\text{MJ t}^{-1}$ rapeseed)
Thermal energy	230.73
Electric energy	36.62
Total energy	267.5

In process of rapeseed cleaning impurities like, chaff, weed seeds, metal particles, sand and stone particles, etc. are removed for better process of mechanical oil extraction and oil quality in pressing (also protection of oil screw press from damages). Rapeseed in our case is after drying additionally cleaned with small seed cleaning machine with electric power 0.25 kW. It is established that average energy consumption for cleaning rapeseed impurities is  $9 \text{ MJ t}^{-1}$  seed. After finishing drying and cleaning follows mechanical extraction of rapeseed oil in family small oil mill. For the analysis of energy consumption in mechanical extraction of rapeseed, continuously screw press with nominal power of  $1.5 \text{ kW}_e$  equipped with frequency converter was used. During the mechanical extraction of rapeseeds the screw type press was connected to electric measuring equipment for measuring consumed electricity. The determined energy consumption during pressing of rapeseed is  $201.6 \text{ MJ t}^{-1}$  of processed seed. For oil filtering was used one stage oil filtering with piston diaphragm oil pump and bag type filter element. Energy consumption for filtering oil produced from 1 t of processed rapeseed was  $2.52 \text{ MJ t}^{-1}$  seed.



**Figure 1** Mechanical extraction of vegetable oils with screw type press in a small oil mill on family farm, measuring equipment for determining electricity consumption of rape seed pressing is connected with the screw type press.

**Energy use for final product – rapeseed oil**

Total direct energy  $E_{oprod}$  used in the production of rapeseed is added to the total direct energy  $E_{oproc}$  used for processing rapeseed into final product – rapeseed oil. The sum of the two mentioned energies is the total direct energy  $E_{finprod}$  used for the production of rapeseed oil.

Table 4: Total direct energy used in conventional and organic production of rapeseed with processes of drying, cleaning and pressing (MJ/t rapeseed)

Operation	Energy use in conventional production (MJ t <sup>-1</sup> rapeseed)	Energy use in organic production (MJ t <sup>-1</sup> rapeseed)
Rapeseed production	945.6	804.0
Drying of rapeseed	267.5	267.5
Rapeseed fine cleaning, pressing and oil filtering	213.1	213.1
<b>Total energy</b>	<b>1426.2</b>	<b>1284.6</b>

Energy consumption for drying, cleaning and pressing of rapeseed, expressed in MJ t<sup>-1</sup> of processed seed, is the same in conventional and organic production. We found that energy consumption for conventional rapeseed production with included drying is 1213.1 MJ t<sup>-1</sup> seed and 1071.5 MJ t<sup>-1</sup> seed with included drying for organic rape seed production. With adding the energy used for fine cleaning and pressing rapeseed and oil filtering to the previous energy consumption data, the total energy consumption for conventional rape seed production is 1426.2 MJ t<sup>-1</sup> processed rape seed and for organic production 1284.6 MJ t<sup>-1</sup> processed rape seed. Energy for drying of rapeseed represents 18.7 % and energy for rape seed fine cleaning, pressing and oil filtering 14.9 % of the total energy for conventional production of rapeseed. In the case of organic rapeseed production, energy for drying of rapeseed represents 20.8 % and energy for rapeseed fine cleaning, pressing and oil filtering 16.6 % of the total energy for production.

Table 5 Total direct energy used in conventional and organic production of rapeseed with processes of drying, cleaning and pressing (MJ t<sup>-1</sup> rapeseed oil)

Operation	Energy use in conventional production (MJ t <sup>-1</sup> rapeseed oil)	Energy use in organic production (MJ t <sup>-1</sup> rapeseed oil)
Rapeseed production	2836.8	2412.0
Drying of rapeseed	802.5	802.5
Rapeseed fine cleaning, pressing and oil filtering	639.3	639.3
<b>Total energy</b>	<b>4278.6</b>	<b>3853.8</b>

We can also express all the data for direct energy consumption in MJ t<sup>-1</sup> rapeseed oil. For production 1 tone of rapeseed oil, we need 3 t of rapeseeds. With amount of oil 33 % in one ton of rapeseed and pressing it with screw type press, we found that for conventional rapeseed production, energy consumption for rapeseed oil production is 4278.6 MJ t<sup>-1</sup> rapeseed oil and for organic rapeseed production 3853.8 MJ t<sup>-1</sup> rapeseed oil.

## CONCLUSIONS

Total direct energy consumption (MJ/ha) in conventional rapeseed production is higher 21.8 % in comparison with direct energy consumption (MJ/ha) in organic rapeseed production. Total direct energy consumption for conventional production of rapeseed oil is 1426.2 MJ t<sup>-1</sup> processed rapeseed and for organic production of rapeseed oil is 1284.6 MJ t<sup>-1</sup> processed rapeseed. Energy for drying of rapeseed represents 18.7 % and energy for rapeseed fine cleaning, pressing and oil filtering 14.9% of the total energy for conventional production of rapeseed. In the case of organic rapeseed production, energy for drying of rapeseed represents 20.8 % and energy for rapeseed fine cleaning, pressing and oil filtering 16.6 % of the total energy for production. For conventional rapeseed production, direct energy consumption for rapeseed oil production is 4278.6 MJ t<sup>-1</sup> rapeseed oil and for organic rapeseed oil production 3853.8 MJ t<sup>-1</sup> rapeseed oil. From the obtained results, it is clear that the consumption of diesel fuel in rapeseed cultivation can be reduced mainly by rational tillage. For the processing of rapeseed in rapeseed oil, it is possible to replace electricity from the public power grid with electricity from renewable energy sources on farms. Instead of heating oil or gas (natural gas, liquefied petroleum gas), on some farms it is possible to use thermal energy produced by burning or gasifying solid agricultural biomass, or thermal energy from biogas cogeneration. By using electrical energy for rapeseed oil extraction (also rapeseed cleaning and oil filtering) and thermal energy for rapeseed drying, from the farm's own renewable energy sources, it is possible to create direct energy savings of 33.7 % for rapeseed oil production on conventional way of farming and 37.4 % for rapeseed oil production on organic way of farming.

## REFERENCES

- Al-Mansour, F., Jejcic, V. (2016). A model calculation of carbon footprint of agricultural products: The case of Slovenia. *Energy* 1 – 9, [www.elsevier.com/locate/energy](http://www.elsevier.com/locate/energy),
- Bogaert, L., Mathieu, H., Mhemdi, H., Vorobiev, E. (2018). Characterization of oilseeds mechanical expression in an instrumented pilot screw press. *Industrial Crops and Products*, Volume 121, <https://doi.org/10.1016/j.indcrop.2018.04.039>, 106-113
- Chapuis, A., Blin, J., Carré, P., Lecomte, D. (2014). Separation efficiency and energy consumption of oil expression using a screwpress: The case of *Jatropha curcas* L.seeds. *Industrial Crops and Products*, Elsevier, 52, 752-761 [10.1016/j.indcrop.2013.11.046](https://doi.org/10.1016/j.indcrop.2013.11.046). hal-01611995
- Dalgaard, T., Halberg, N., Porter, J.R. (2001). A model for fossil energy use in Danish agriculture used to compare organic and conventional farming, *Agriculture, Ecosystems and Environment* 87, Elsevier, p. 51 – 65
- Handler, F., Nadlinger, M. (2012). Trainer handbook, D 3.8 Strategies for saving fuel with tractors, EU project Intelligent Energy Europe, Efficient 20, IEE/09/764/SI2.558250

- Ježic, V., Al-Mansour, F. (2014). Carbon footprint of conventional and organic crop production. Proceedings of the 42nd International Symposium on Actual Tasks on Agricultural Engineering, Opatija, Croatia, 25-28 February 2014
- Katić, Z. (1997). Sušenje i sušare u poljoprivredi, Udžbenici Sveučilišta u Zagrebu, Manualia Universitatis studiorum Zagrebiensis
- Mizera, Č., Herák, D., Hrabé, P., Kabutey, A. (2018). Extraction of oil from rapeseed using duo screw press. *Agronomy Research*, vol. 16, Special Issue 1, 1118-1123, <https://doi.org/10.15159/AR.18.059>
- Özilgen, M., Sorgüven, E. (2011). Energy and exergy utilization, and carbon dioxide emission in vegetable oil production, *Energy* 36, 5954 – 5967, [www.elsevier.com/locate/energy](http://www.elsevier.com/locate/energy)
- Peltola, A. (1985). Energiansäästö viljan lämminilmakuivauksessa. In Laitinen A., Orava R., Peltola A., Salasmaa O. & Ylönen A-L. *Energiansäästö viljankorjuussa*. Työtehoseuran julkaisuja 272. Työtehoseura 1985.
- Scott, S. (2017). Reclaiming Corn Drying Energy. Factsheet 17-001 AGDEX 111/736 January 2017, replaces OMAFRA factsheet 88-003, University of Wisconsin-Madison, USA
- Suomi, P., Lötjönen, T., Mikkola, H., Kirkkari, A-M & Palva R. (2003). Viljan korjuu ja varastointi laajenevalla viljatilalla. *Maa- ja elintarviketalous* 31. Maa- ja elintarviketalouden tutkimuskeskus
- Thuncke, K., Remmele, E. (2007). Production and Utilisation of Rapeseed Oil Fuel in Germany, proceedings 6<sup>th</sup> International Colloquium Fuels. Technische Akademie Esslingen (TAE), 10-11 January 2007, TAE Osfildern, Stuttgart, Germany



## STATISTICAL METHODS AND ARTIFICIAL NEURAL NETWORKS IN THE OPTIMIZATION OF HEATING PELLETS AND BRIQUETTES

Cristian BEJERITA<sup>1</sup>, Adriana-Carmen CAZAN<sup>1\*</sup>, Nicoleta CONDESCU-ULARU<sup>2</sup>,  
Liliana DORNEANU<sup>2</sup>, Cristian COSARIU<sup>2</sup>, Simina MARIS<sup>2</sup>

\*E-mail of the corresponding author: [adrianacazan20@gmail.com](mailto:adrianacazan20@gmail.com)

<sup>1</sup>Politehnica University of Timisoara, Romania

<sup>2</sup>Ioan Slavici University of Timisoara, Romania

### ABSTRACT

*The agribusiness sector demands regular balanced cost-benefit solutions. Artificial intelligence will be used to obtain complex solutions that are easily applicable. The objective of this paper is to use innovative instruments from the domain of artificial intelligence to enhance the decision-making process linked to energetic crops and their usage. The field of expertise covered by this paper is directly related to current issues of sustainable development of the environment. It will describe the usage of artificial neural networks – ANN - in determining the affordable income of heating and food pellets obtained in an agricultural venture. This paper aims to provide software for ash and Q as far as pellet recipes are concerned. In this case, it will be emphasized that the pellets are composed of sawdust and other wood waste, which are dehydrated and compressed into granules to be introduced into the heating system. Because all the materials they are composed of are biological and biodegradable elements, pellets are an environmentally friendly fuel, and the level of carbon dioxide resulting from their combustion is particularly low. The residues generated from the burning of pellets are not harmful to the environment, leaving behind fine ash that can even be used as fertilizer in crops. For the manufacture of pellets, agricultural and wood waste and other residual materials are used, which are then compacted. Due to the density of the pellets, but also their low humidity, their combustion will occur at higher temperatures, which will allow you to enjoy efficient heating throughout the home.*

**Keywords:** Pellets, Briquettes, Artificial Neural Networks, Artificial Intelligence, Energetic Crops, Environment, Sustainable development

## INTRODUCTION

Industrial development requires ever-increasing amounts of energy, which has led to the need to develop new, more efficient, less polluting energy resources that allow long-term exploitation. Among the biomass processing technologies for the purpose of obtaining energy, wood pellets and briquetting have an increased efficiency. The results are equally based on the research carried out in the INOMAT project (INOMAT 2020) and on the doctoral thesis of S. Maris, with the theme "*Contributions to the optimization of the manufacturing processes of pellets and briquettes using elements of artificial intelligence, statistics and operational research*" (Maris 2022).

If profit maximization is important from the point of view of the economic agent (Botez and Enachi, 2021), it is conditioned by the improvement of the quality of the products offered (Botez, 2018). Thus, a scientific production planning is required, as well as industrial research-development activities. By using experiment planning techniques, modeling techniques and numerical simulation software, the costs of experimental research activities can be reduced.

In the first place, heating with pellets is an economical and environmentally friendly solution, compared to fossil fuels (oil, gas, etc.). The investment in the power plant and the related equipment is amortized quite quickly and it can be safe and easy in terms of handling / use. The pellets burn completely and leave behind very little ash, this being a good fertilizer for gardens, and at the same time it does not emit a specific, disturbing smell. They burn for up to 12 hours and release heat in the long term, with an excellent yield of 80 - 95%, depending on the composition.

Secondly, heating using briquettes is an economical and environmentally friendly solution, compared to fossil fuels (oil, gas, etc.). From the point of view of handling and use, it is safe and easy, and its efficiency is four times higher than traditional wood heating. The briquettes burn almost completely, and the ash left after burning is a good fertilizer for gardens. It offers a good and very good yield, of 70 - 85%, depending on the composition. (DiGiacomo, 2009)

In the case of the manufacture of pellets and briquettes, the optimization of the manufacturing process can refer to maximizing profit (Untaru, 2013), increasing productivity (Stelte 2014), recycling agricultural or forestry waste, maximizing calorific power (Maris et al, 2017), meeting technical standards, determining manufacturing recipes specific to each of these cases (Maris et al, 2018), to innovative solutions for the automation of the production line. In this case, an improved production line is presented to meet the requirements, a line already built at the Cenei factory. Both empirical recipes and a scientific planning of experiments are considered.

The possibility of effectively using wood or agricultural waste for energy production is a current trend. Although woody biomass is a traditional energy source, new technologies allow it to be used in a more efficient way.

## MATERIALS AND METHODS

The specifications of solid biofuels such as pellets and briquettes are subject to standards that are constantly being updated. The EU regulations for these types of biofuels are included in EN 17225-1 (CEN 17225-1, 2014), EN 17225-2 (CEN 17225-2, 2014) and EN 17225-6



(CEN 17225-6, 2014), which are updates of EN 14961 (CEN 14961, 2010) and EN 14961-4 (CEN 14961-4, 2010).

**Table 1** Standards for wood pellets (CEN 17225-2, 2014)

Characteristics	Unit of measure	ENPLUS A1	ENPLUS A2	ENPLUS B
<b>Minimum diameter</b>	[mm]	6.1	6.1	6.1
<b>Maximum diameter</b>	[mm]	8.1	8.1	8.1
<b>Minimum length</b>	[mm]	3.15	3.15	3.15
<b>Maximum length</b>	[mm]	40	40	40
<b>Maximum humidity</b>	% (wet base)	10	10	10
<b>Net calorific value, Q</b>	MJ · kg <sup>-1</sup>	16.56	16.56	16.56
<b>Minimum bulk density</b>	kg m <sup>-3</sup>	600	600	600
<b>Maximum additives</b>	% (dry base)	2	2	2
<b>Maximum residual ash</b>	% (dry base)	0.7	1.2	2
<b>Raw material (origin)</b>		Trunks; Wood residues not chemically treated	Trees without roots; Trunks without bark; Forestry waste; Wood residues not chemically treated	Forests, plantations, and unprocessed wood; By-products and residues from the wood processing industry; Used wood not chemically treated

One of the most used software solutions for implementing neural networks is Matlab. This software is a solution developed by MathWorks, which allows mainly numerical calculations, matrix manipulation, graphic representations, implementation of algorithms, creation of user interfaces, but also interference with other programming languages. MATLAB is used to determine a neural network that links artificial intelligence methods to possible outcomes. (Chapman, 2015)

Matlab was used to build an artificial neural network which links the available data on fuels (i.e. calorific value and residual ash) to the elemental composition of the fuel (i.e., percentages of C, H, N, O, S, Cl in the raw material). Thus, the input of the ANN is a vector with 2 elements (calorific value and residual ash) and the output is a vector with 6 elements (percentages of C, H, N, O, S, Cl in the raw material). The structure of the ANN also includes 2 hidden layers, the first one with 10 neurons and the second one with 6 neurons. The transfer function is a sigmoid function. The training algorithm used is the Levenberg Marquardt algorithm.

The data were statistically processed with STATGRAPHICS because the program finds the best combination of the experimental factors. Users specify the target value or acceptable range for each response, together with its relative importance. (Statgraphics, 2009)

In successful endeavors, certain equipment and technologies are needed in order to produce and burn heating materials (e.g., pellets, briquettes). These are briefly presented below:

- technological line for the production of pellets/briquettes (Figure 1);
- pellet press for experimental pellet manufacturing (Figure 2);
- briquettes press (Figure 3);
- combustion stove (Figure 4.)



**Figure 1** Technological line for the production of pellets



**Figure 2** Small capacity pellet press



**Figure 3** Briquettes press



**Figure 4** Combustion stove

## RESULTS AND DISCUSSION

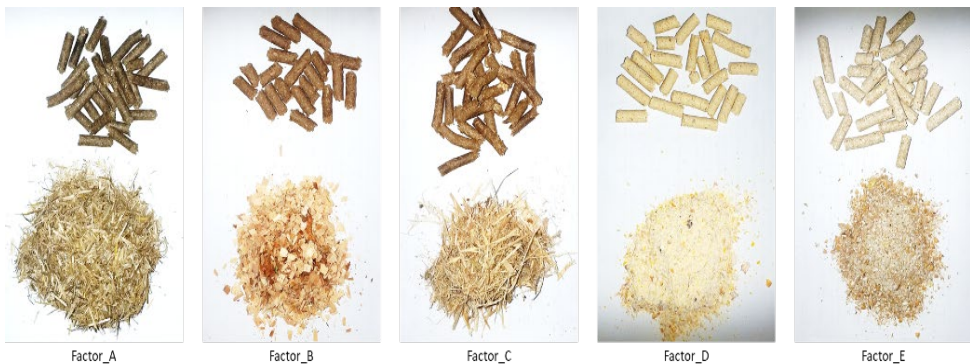
In order to delimit the burning measures of pellets and briquettes, the following are proposed - Q (calorific value, expressed in  $\text{MJ}\cdot\text{kg}^{-1}$ ) and the amount of ash (ash, expressed as mass percentage). Data was processed with STATGRAPHICS. The data refers to 5 types of biomass available in the area: straw, beech sawdust, wood chips, corn, wheat (as depicted in Table 3 and Figure 5).

**Table 2** Project measurements for pellets and briquettes

Output	Goal	Minimum	Maximum
Calorific value $Q_{\text{inf}} (\text{MJ} \cdot \text{kg}^{-1})$	Maximize	14.50	-
Residual ash (%)	Minimize	-	10.00

**Table 3** Experimental factors involved in the project (Maris, 2022)

Experimental factor	Unit of measure	Factor	Minimum values	Maximum values
<b>A: Factor _ A</b> Straw	mass %	Mixture component	0.0	1.0
<b>B: Factor _ B</b> Beech Sawdust	mass %	Mixture component	0.0	1.0
<b>C: Factor _ C</b> Wood chips	mass %	Mixture component	0.0	1.0
<b>D: Factor _ D</b> Corn	mass %	Mixture component	0.0	1.0
<b>E: Factor _ E</b> Wheat	mass %	Mixture component	0.0	1.0



**Figure 5** Factors of the experiment (Maris, 2022)

The formula used for computing the ash content is:

$$ash = \frac{m_2}{m_1} \cdot 100 [\%] \tag{1}$$

where  $m_1$  is the weight before the burning process, and  $m_2$  is the weight of the ash resulted through burning.

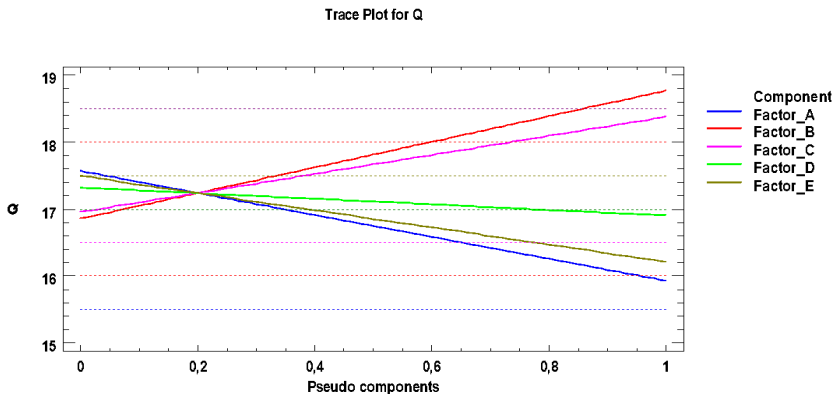
The formula used for determination of the calorific value is:

$$Q = \sum_{i=1}^n m_i Q_i [MJ \cdot kg^{-1}] \tag{2}$$

where  $m_i$  is the weight percentage of the component  $i$ , and  $Q_i$  is the calorific value of the component  $i$ .

The data analysis reveals that there is a strong direct relationship between the calorific value of the mixture and the factors B and C and a strong inverse relationship between the calorific value and factors A and E. (Figure 6). This signifies that the calorific value increases as the mass percentage of beech sawdust and wood chips increase, but an increase of the percentage of straw and wheat leads to a decrease of the calorific value of the resulting mixture.

The calorific value of the mixture is between  $15.8 MJ \cdot kg^{-1}$  and  $18.8 MJ \cdot kg^{-1}$ , with the highest value for a mono-component mixture of beech sawdust and the lowest value for a mono-component mixture of straw.

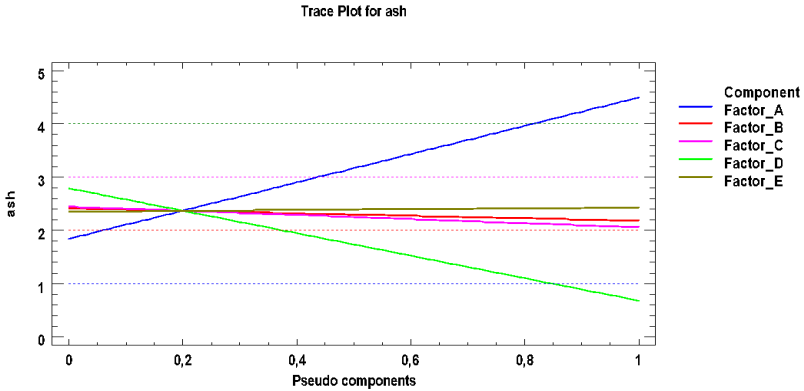


**Figure 6** The influence of the mixture factors on the calorific value Q

Regarding the amount of residual ash, there is a strong direct relationship between it and factor A and an inverse one, of lesser intensity, between it and factor D. In other words, an increase in the amount of straw in the mixture results in an increase in the amount of ash, while an increase in the amount of corn in the mixture results in a decrease in the amount of residual ash (Figure 7).

In general, the combination will have a residual ash of between 2% and 3%. Values above 3% are possible for a percentage of more than 45% straw in the composition of the mixture.

Values below 2% are possible for more than 40% corn and less than 7% straw, and a residual ash value close to 1% is possible for mixtures consisting only of non-conforming corn.



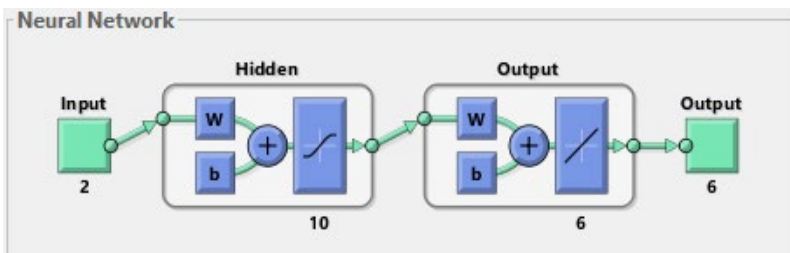
**Figure 7** The influence of the mixture factors on the residual ash

Neural networks were used to determine the emissions (noxes) starting from the calorific value and the residual ash. Emissions are related to the amounts of N, S, Cl present in the mixture and, ultimately, in the raw material. In order to determine these amounts a neural network was developed which computes the elemental composition of a material based on the calorific value and residual ash (which can be easier obtained through experiments). The neural network is a function

$$y = f(w \times x + b) \tag{3}$$

where  $y$  is a 6-element vector corresponding to the percentage elemental chemical composition (C, H, O, N, S, Cl),  $x$  is a 2-element vector corresponding to the values for the lower calorific value in MJ/kg and the amount of ash in the %,  $w$  is the weight vector (i.e., a vector containing the weights associated to the inputs) and  $b$  is the bias vector (i.e., a vector containing bias values which affect the computations).

The neural network has an input layer with 2 neurons, two hidden layers with 10 and 6 neurons, respectively, and an output layer with 6 neurons (Figure 8).

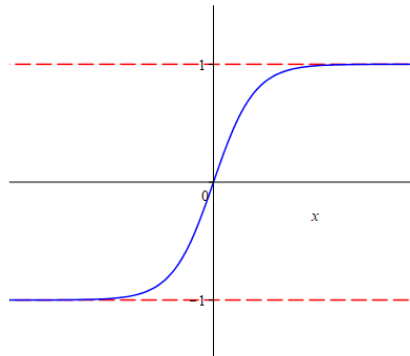


**Figure 8** Neural network structure

The transfer function for the hidden layer is a sigmoid function

$$a = \frac{2}{1 + e^{-2n}} - 1 \tag{4}$$

with values between -1 and 1, as depicted in Figure 9.



**Figure 9** The sigmoid transfer function used in RNA modeling

The precision of the neural network is 0.99667 for the training phase, 0.9968 for the validation phase and 0.99042 for the test phase. Overall, the precision of the neural network is 0.99581.

This signifies that the amount of emissions of a certain type of pellets / briquettes can be determined very accurate by using the neural network constructed.

## CONCLUSIONS

Starting from the need for innovation in the production of heating pellets and briquettes, expressed by a company active in the field, the present research provided a series of answers related to the innovation of the product recipes, the possibility of diversification of production and the determination of optimal recipes given the raw materials available to be processed.

Characteristics of some empirical recipes were studied (lower calorific value, ash, emissions).

In addition, an artificial neural network for predicting the elemental composition (and thus the emissions of burning different types of pellets / briquettes) based on the calorific value and ash contents of certain materials.

## REFERENCES

- Botez, D. (2018). Recent Challenge for Auditors: Using Data Analytics in the Audit of the Financial Statements. *BRAIN. Broad Research in Artificial Intelligence and Neuroscience*, 9(4), 61-71.
- Botez, D., & Enachi, M. (2021). Some aspects regarding the future of financial reporting. *Studies and scientific researches. Economics edition*, (33).

- CEN (European Committee for Standardization), EN 17225-2 (2014). Solid biofuels – Fuel Specification and classes, Part 2 – Graded wood pellets.
- CEN (European Committee for Standardization), EN 17225-6 (2014). Solid biofuels – Fuel Specification and classes, Part 6 – Graded non-woody pellets.
- CEN (European Committee for Standardization), EN 14961 (2010). Solid biofuels – Fuel Specification and classes, Part 1 – General requirements.
- CEN (European Committee for Standardization), EN 14961-4 (2010). Solid Biofuels - Fuel Specifications and Classes - Part 4: Wood Chips For Non-Industrial Use.
- Chapman, S. J. (2015). MATLAB programming for engineers. Nelson Education.
- DiGiacomo, G., & Taglieri, L. (2009). Renewable energy benefits with conversion of woody residues to pellets. *Energy*, 34(5), 724-731.
- Maris, S. (2022). Contributions to the optimization of pellets and briquettes manufacturing processes using elements of artificial intelligence, statistics and operational research. Doctoral thesis, Politehnica University of Timisoara, Romania
- Maris, S., Nenu, P. F., Maris, S. A., & Slavici, T. (2017). Estimating the calorific value of pellets from different blends of biomass. In *Proceedings of the 45th International Symposium on Agricultural Engineering, Actual Tasks on Agricultural Engineering*, 21-24 February 2017, Opatija, Croatia, 459-464.
- Maris, S., Cernescu, L. M., Maris, S. A., Darvasi, D., & Slavici, T. (2018). Determining efficient mixtures of biomass for pellet production. In *Proceedings 46th International Symposium: Actual tasks on agricultural engineering*, Opatija, Croatia, 27th February-1st March, 2018, 359-368.
- Project INOMAT (2020). “Innovations and economic and functional optimizations in the industrial production of materials for thermal energy” - INOMAT, project financed by the “Competitiveness” Operational Program, SMIS code 119412
- Statgraphics. (2009). Design of Experiments. <https://www.statgraphics.com/design-of-experiments>
- Stelte, W. (2014), Optimization of product-specific processing parameters for the production of fuel pellets from torrefied biomass, Taastrup, Denmark: Center for Biomass and Biorefinery, Danish Technological Institute
- Untaru, M. (2013). Analiza Economico-Financiara. Editura Eurostampa, Timisoara.

---

---





## CONTEMPORARY MANUFACTURING TECHNIQUES USED IN AGRICULTURAL ENGINEERING

Adriana-Carmen CAZAN<sup>1</sup>, Cristian BEJERITA<sup>1</sup>, Alexandra SUTA<sup>1</sup>,  
Andrei-Alin VOINESCU<sup>1</sup>, Larisa Georgiana MATEI<sup>1</sup>, Simina MARIS<sup>1</sup>,  
Daniel BOTEZ<sup>3</sup>, Titus SLAVICI<sup>1,\*</sup>

\*E-mail of the corresponding author: titusslavici@yahoo.com

<sup>1</sup>Politehnica University of Timisoara, Romania

<sup>2</sup>Ioan Slavici University, Romania

<sup>3</sup>University "Vasile Alecsandri" of Bacau, Romania

### ABSTRACT

*The goal of this article is to introduce contemporary manufacturing techniques in real life examples. Whereas simulation activities are widespread in aerospace, automotive, manufacturing equipment, medical industries, this research aims to introduce these techniques in the agriculture industry. Physical agricultural equipment will be reverse engineered to get the CAD copy or digital twin. After this, manufacturing equipment and activities will be simulated and optimized virtually. One of the techniques to be used is graph theory. The technological line is an application of graph theory to optimizing manufacturing equipment interconnectivity. Manufacturing activities have been modelled as graphs. Workstations or manufacturing equipment are vertices. The ties amongst vertices are edge, links, or lines. This paper finds application in the practice of technological lines comprising several working stations. The graph theory may be used to find the critical path method. This shows the activities that need to be executed in order to schedule manufacturing feasibly via the routing. The methodology is an empirical case study on a manufacturing line funded via European funds, now in construction at Cenei. The project is intended to be used for academic research and it is constructed by academia. The results from the project will be disseminated in academic studies, supporting laboratory tests with empirical implications and benefits.*

**Keywords:** reverse engineering, digital twin, 3D modelling, graph theory, critical path method

## INTRODUCTION

The EU 2020 policy targets the increased use of renewable energy sources and reduction of greenhouse gas (GHG) emissions are among the main drivers. The European Union aims to develop an environmentally friendly society, based on renewable energy (Ines et al, 2020), which guarantees an efficient use of the resources and makes the renewable energy sector a top priority for the EU (Anton and Afloarei Nucu, 2020).

Today's manufacturing operations integrate resources in a more complex manner than in the past. Moreover, localised economy is replaced by global economy. Such levels of scale and complexity require extensive collaboration (Martín-Gamboa et al, 2020; Obernberger and Thek, 2010). This article's goal is to provide a case example where new technologies are blended with traditional technologies and to analyse this case example in detail.

Agribusiness represents a new approach which combines advanced computerization or digitalization technologies with traditional approaches to agriculture (King, 2010, Filipovici et al, 2014). The economics of the New Economy and Industrial Economy are working together (Enachi and Botez, 2021). A segment of agribusiness, the pellets sector, manufacturing process and key issues are analysed in detail by Untaru et al (2012) and Maris et al (2017). This research is an experimental case study about a pellet manufacturing line funded by the European Union, where manufacturing processes are modelled using graph theory. The application of Graph theory is the author's add-on to the Maris thesis (Maris, 2022) on this production line. It is intended to bring a mathematical method to manufacturing scheduling that can be described, analysed and tested in practice.

This study analyses several types of solutions to be used in a production line for pellets and briquettes by using methods like the graph theory that will have an impact on automating the entire pellet manufacturing process. The study analyses this model to show the best way of automatization that should give a positive response to the request of a better way to obtain pellets and briquettes. This shows the activities that need to be executed in order to schedule manufacturing feasibly via the routing.

## MATERIALS AND METHODS

This research concerns the use of graph theory and methods to determine the critical path for an improved use of the pellet production line. This will help the entire production by giving the best size and humidity of the material that will be converted into a pellet or a briquette.

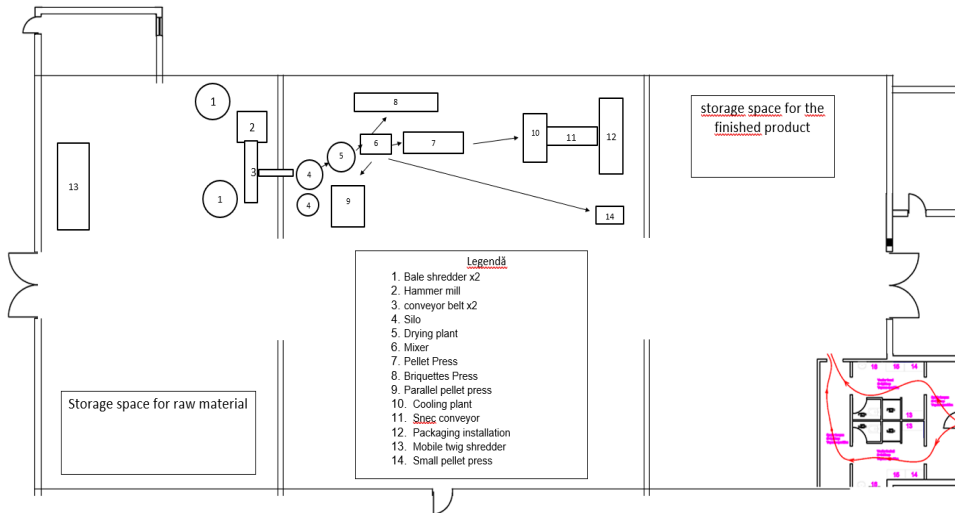
Our database was constructed using data from our production line in Cenei as it can be shown in Figure 1.

### *Graph Theory applied to manufacturing techniques*

In optimizing the location of the equipment on the technological line, the graph theory was applied – with reference to graphs, vertices, arcs (Chen et al, 2011). This is a transport problem and can be formulated as follows (Deo, 2017):

- Given a set of nodes (equipments)  $D_1, \dots, D_n$ , with the capacity  $b_1, \dots, b_n$
- Given a set of nodes (equipments)  $C_1, \dots, C_m$ , which consume the quantities  $b'_1, \dots, b'_m$
- Given the unit cost of freight  $c_{ij}$  from equipment  $i$ . to the equipment  $j$

- Find the amount of raw material to be transported from each equipment  $i$  to each equipment  $j$  such that the transport cost is minimal and does not exceed the storage / processing capacity of any equipment.



**Figure 1** Scheme of the existing production line (Cenei)

The transport problem can be expressed mathematically as:

$$f = \sum_{i=1}^n \sum_{\substack{j=1 \\ j \neq i}}^n c_{ij} x_{ij} \quad , \quad 0 \leq c_{ij} \quad (1)$$

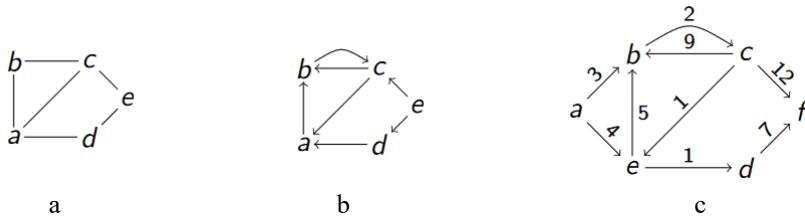
$$b'_i \leq \sum_{\substack{j=1 \\ i \neq j}}^n x_{ij} \leq b_i \quad (2)$$

$$\sum_{\substack{i=1 \\ i \neq j}}^n x_{ij} \geq b'_j \quad (3)$$

The previous problem can be solved using graph theory (Vedavathi, and Gurrarn, 2013).

The solution of the problem can be obtained either by using the nearest neighbour algorithm (Evans, 2017), or a simplex algorithm (Ionica et al, 2019).

A finite set,  $V$ , endowed with an internal binary relationship,  $E$ , is called a graph (Deo, 2017). The graph is denoted  $G=(V,E)$ . Any element of the set  $V$  is called a vertex (vertex), and any element of the set  $E$  is called an arc (edge or line).

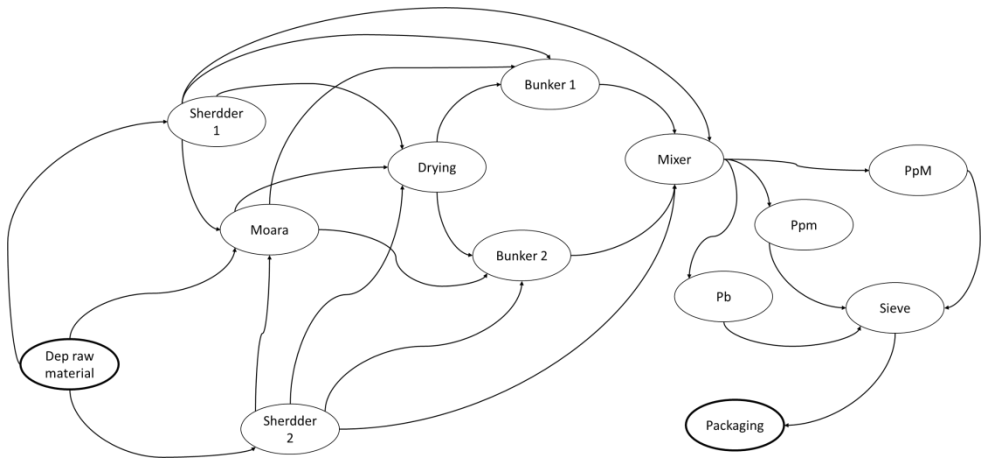


**Figure 2** Examples of graphs: a - graph, b – oriented graph, c – weighted graph (after Evans, 2017)

An oriented graph is a pair of sets  $G=(X,U)$ , where  $X$  is a finite non-empty set, the elements of which are called vertices, and  $U$  is a set of pairs ordered by the form  $(x,y)$ , with  $x$  and  $y$  elements of  $U$ , called the set of arcs (edges).

A graph whose arcs each have an associated number (called the weight of that arc) is called a weighted graph (Deo, 2017).

The graph describing the technological line is presented in Figure 2.



**Figure 3** Oriented graph associated to the technological line

Figure 3 shows that the mixer the raw material can only reach one of the presses and then the sieve and the packaging plant. The optimization problem is finding the appropriate means for the raw material to be transferred from the warehouse to the mixer. If the raw material is sufficiently dry, then it will no longer require to go through the drying phase, being transported directly to the bunkers. If the processing capacity of the shredders is less than the processing capacity of the mixer, then there is no need for the raw material to be stored in the bunkers.

### ***Cloud Manufacturing***

The cloud platform first collects the manufacturing service requests from customers and the offers from suppliers (Cozmiuc and Petrisor, 2018). The above-mentioned requests are then processed via intelligent decision-making algorithms in order to find the best manufacturing solution according to the user needs. To perform these tasks, the platform includes a database module where user input data are collected, an intelligent module for data processing, optimization and feasible solutions generation, and a decision support module for solutions evaluation and comparison.

In order to be able to adapt the existing plant line from Cenei to the cloud manufacturing techniques, an efficient computerized system for the whole production line is required, in order to make the entire process be controllable from any device that the technicians use.

This is possible by mounting sensors and operating the line according to their readings. First, it is necessary to mount a humidity sensor that will provide data about the total humidity of the material that will be coming out of the shredder (Figure 4). The goal of this sensor is to provide information about material humidity before leaving the shredder. By doing so, it will be possible to know if the material needs to move to the mixer (Figure 5) for a second drying process.



**Figure 4** Shredder (Industrial Park Cenei)

The ideal situation is that the material should have a humidity level between 10% - 15%.



**Figure 5** Horizontal mixer (Industrial Park Cenei)

If the material doesn't have proper humidity (between 10% - 15%), mixed or shredded material will have to be moved to the drying installation (Figure 6). By doing so, material humidity can reach 12-15%. This will enable material to get to the next phase of the production plant.



**Figure 6** Drying installation (Industrial Park Cenei)

There will be a second phase for getting the entire plant to automatization where sensors will be mounted for the filling level from the material fuel tank. The sensors could provide information about the quantity of the material that is inside the fuel tank and outside on the

processing line that will notify if there are problems with the outcome material from the shredder and income material from the mould. In that case it will be possible to find the best technical road to obtain pellets and briquettes.

## RESULTS AND DISCUSSION

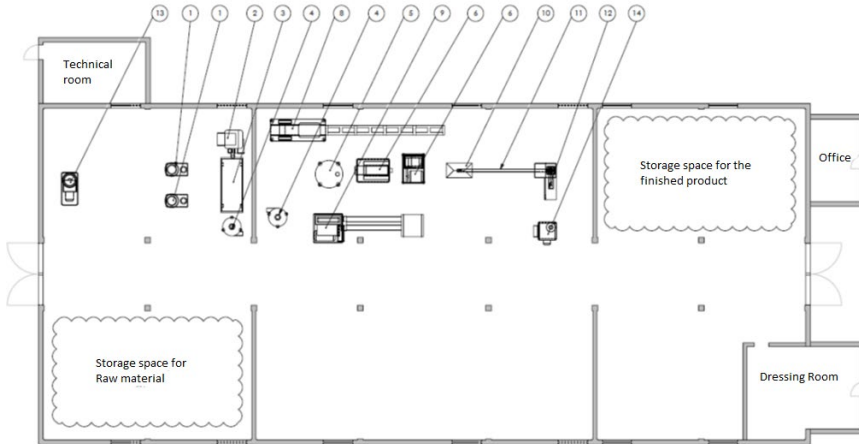
The central purpose of this research was to find a strong relationship between economic efficiency and the technical efficiency of the plan production of pellets and briquettes that could provide a better optimization provided by the machinery emplacement.

By applying graph theory to the collected data, several variants of positioning the machines were devised, aiming at optimization by reducing the transfer times, the length of the half-finished routes, and the realization of intermediate functions.

The aim was also to achieve an interchangeability in the sense that the prepared, cut, shredded matter could feed the following 4 types of final products realization:

- standard pellets with high productivity,
- pellets obtained for research,
- standard pellets/ briquettes,
- brick-type parallelepiped briquettes.

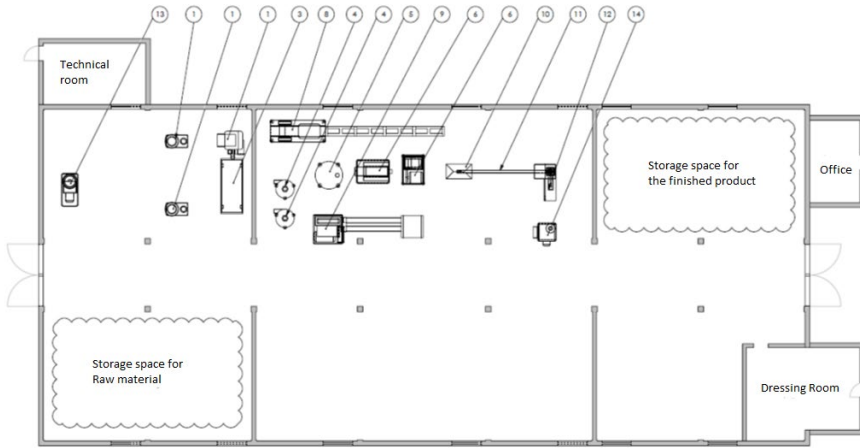
The initial technological line ensured, in conditions of granulation and humidity corresponding to the pelletization process, a technological flow of 380-400 kg h<sup>-1</sup>.



**Figure 7** Intermedial arrangement of the technological line

The arrangement of the equipment according to the diagram in Figure 7 ensured, in conditions of humidity and appropriate granulation, a technological flow of 400-430 kg h<sup>-1</sup>.

The final location of the machines, which takes into account the need to improve the technological line, is shown in Figure 8.



**Figure 8** The final arrangement of the technological line

This location ensures that the losses on the route are minimal because the distances between the feed equipment (shredders, hammer mill) are approximately equal. The raw material that has too much moisture will pass through the silo adjacent to the dryer, then into the dryer and further into the mixer. The raw material that has the appropriate humidity will pass directly into the mixer. After the mixing process, the raw material will reach the pellet line and will be pelletized.

The final arrangement of the technological line ensures, in conditions of adequate humidity and granulation, a technological flow of  $500 \text{ kg h}^{-1}$ .

## CONCLUSIONS

All arguments considered, the study provides useful information for using Graph Theory to help use a more optimal cycle in the pellets and briquettes manufacturing process to give shorter and more efficient working time.

The most important contribution is the use of the graph theory at the adaptation of the system to be operated remotely by computer, because this enables important information to be generated in real time and creating the possibility of shorter and more efficient cycle for making pellets and briquettes.

## REFERENCES

- Anton, S. G. & Nucu, A. E. A. (2020). The effect of financial development on renewable energy consumption. A panel data approach. *Renewable Energy*, 147, 330-338.
- Chen D.S., Batson R.G. & Dang Y. (2011). *Applied integer programming: modeling and solution*. John Wiley & Sons
- Cozmiuc, D., & Petrisor, I. (2018). Industrie 4.0 by siemens: steps made next. *Journal of Cases on Information Technology (JCIT)*, 20(1), 31-45.



- Deo, N. (2017). Graph theory with applications to engineering and computer science. Courier Dover Publications.
- Enachi, M. & Botez, D. (2021). Relativity of accounting values: causes, consequences and limitation possibilities. *Studies and Scientific Research. Economic Edition*, 33, 33-39.
- Evans, J. (2017). Optimization algorithms for networks and graphs. Routledge.
- Filipovici, A., Mneric, A. V.; Badescu, D., Bota, M., Maris, S., Baesu, V., Slavici, T. & Ungureanu, D. (2014). Agribusiness projects assessment using cost-benefit analyses. In *Proceedings of the 42nd International Symposium on Agricultural Engineering, Actual Tasks on Agricultural Engineering*, Opatija, Croatia, 25-28 February 2014, 439-445.
- Ionica, D., Maris, S.A., Dicu, R. & Maris, S. (2019). Linear Programming Tool for the Optimization of Mixed Biomass Fuel Recipes. *BRAIN – Broad Research in Artificial Intelligence and Neuroscience*, 10(3), 139-149.
- Ines, C., Guilherme, P. L., Esthera, M.G., Swantje, G., Stephen H. & Lars, H. (2020). Regulatory challenges and opportunities for collective renewable energy prosumers in the EU. In: *Energy Policy*, Elsevier, Volume 138, 111-212.
- King, R. P., Boehlje, M., Cook, M. L. & Sonka, S. T. (2010). Agribusiness Economics and Management. In: *American Journal of Agricultural Economics*, Volume 92, Issue 2, 554–570.
- Maris, S. (2022). Contributions to the optimization of pellets and briquettes manufacturing processes using elements of artificial intelligence, statistics and operational research, Doctoral thesis, Politehnica University of Timisoara, Romania
- Maris, S., Slavici, T., Nenu, P., & Baciuc, L. (2017). Artificial Intelligence as a Decision-making Tool in Planning the Research. *BRAIN. Broad Research in Artificial Intelligence and Neuroscience*, 8(3), 69-76.
- Martín-Gamboa, M., Marques, P., Freire, F., Arroja, L. & Diasa, A. C., (2020). Life cycle assessment of biomass pellets: A review of methodological choices and results. In: *Renewable and Sustainable Energy Reviews*, Elsevier, Volume 133, 110-278.
- Obemberger, I. & Thek, G. (2010). *The Pellet Handbook The Production and Thermal Utilisation of Pellets*. Earthscan
- Untaru, M., Rotarescu, V. & Dorneanu, L. (2012). Artificial Neural Networks for sustainable agribusiness: a case study of five energetic crops. *Agrociencia*, 46(5), 507-518.
- Vedavathi, N., & Gurram, D. (2013). Applications on graph theory. *International Journal of Engineering Research and Technology*, 2(1), 1-4.

---

---



## FARMERS COOPERATION IN PROCUREMENT AND DISTRIBUTION OF GOODS USING ONLINE-MARKETPLACE

László MAGÓ

E-mail: Mago.Laszlo@uni-mate.hu

*Department of Engineering Management, Institute of Technology,  
Hungarian University of Agriculture and Life Sciences  
Páter K. u. 1., Gödöllő, H-2103, Hungary*

### ABSTRACT

*Aim of this paper is to introduce a model, which provides effective solutions and support for establishment of the agricultural input and output market systems. Input used in agriculture are mostly technical systems, chemical materials and biological products. The output are the crops, livestock products and energy. As estimated, in Hungary the turnover of the input could approach a several billion EUR annually. It is supposed that the input side pressure is indicated in 15-20 % of extra profit from traders towards producers, which means that producers' profit possibilities are reduced by this rate in the rate of utility. On the other hand, annual sponsored limits of agriculture have been realized to a great extent by purchasers of produced materials through the pressured purchase price.*

*As a consequence, profit of agriculture is extremely low and production enlargement is not possible. Possibility to change this situation can be the online-marketplace, which can be created at the input or/and output side. These fields could improve procurement and distribution conditions of agriculture and imply chances to enlarge production through better profit.*

**Keywords:** *farmers cooperation, online-marketplace, inputs of agricultural production, price competitions, profit maximisation*

### INTRODUCTION

In Hungary the former system, which worked intensively has been the “production systems” based on big factories (Tardos and Sári, 2003; Balogh, 2012). These systems have been established along production paths (Szabó, 2000; Szabó, 2011). The system administrators have provided the input, they have worked up the production experience, and

hence a “self-learning” system has been made. They have taken expectations of the market that time into consideration. For the time being the production structure and the market have been altered and we have not found the production system that could meet the challenges (Tóth, 2000; Széles, 2003)

Changing of the present European Common Agricultural Policy (CAP) can be expected (Walenia, 2022). Decreasing the deforming impact of the supporting system the role of innovation is more and more important (Fieldsend, 2020). Our model supports it effectively in many areas (e.g. optimization of invests and operation, reducing of production costs, increase of the research efficiency). Our unique agricultural possibilities are capitalized using the planned up-to-date information system, making competitive advantage for farmers and food industry. In addition, the system will be advantageous for inputs production, mostly for agricultural machine industry (Teuteberg, 2020; Kusumawati et al., 2022).

In a small-scale farm environment significant savings can be achieved by the common utilisation of the machines and by the employing professional machine works both in the investments and the machine operation (Nagy, 2007; Magó, 2009). Those beneficial machine service and collaboration forms are used worldwide, especially in the agriculture of the developed countries (Nagy and Magó, 2004; Tot et al., 2018). In past years status quo analyses and the evaluation of experience showed that there is need for the farmers cooperation in the East European countries including Hungary for the rational utilisation of resources and to improve the efficiency of assets and to minimize costs (Takács, 2001). However, the organizations, structures, schemes, models and frames of standard forms has not been formed as yet, so that the utilisation of the advantageous solutions is on quite a low level (Magó, 2007; Schnicke, 2011).

The successful formulation of machine utilisation and business supporting forms decisively depend on the conditions and the appropriate knowledge about the properties of the different forms (Baranyai and Takács, 2007). It is highly important that all the factors and characteristics should be discovered for the benefits and disadvantages of forms from the organisational, operational, economical, and all the other points of view in order to determine and declare the criteria of introduction for each economy circles of farmers (Takács and Baranyai, 2010; Yuan, 2022; Etro, 2021).

## METHOD

The relationship between producers and input providers is quite determined in the field (Koester, 2020). It means that input users are connected tightly by the agency of manufacturers and traders and their relationship is determined by traders’ profit maximisation. In this relationship a producer has hardly any possibility to compare complete supply portfolios and validate suppliers’ most favourable proposals (minimal procurement price, the best quality, etc.).

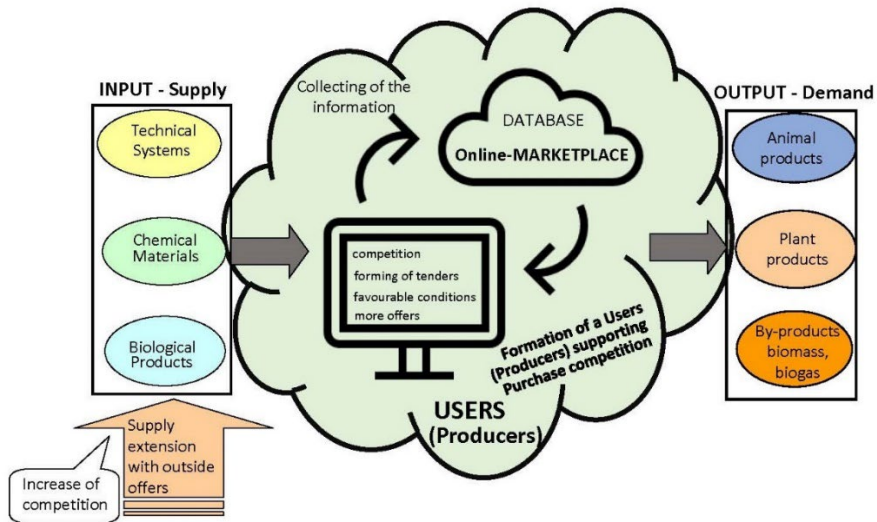
Aims of this model are:

- establishment of competition situation among input providers,
- enlargement of supply side,
- discontinue inflexible trade structures in order the most favourable procurement conditions could be made.

The system enables the producers' common tender announcement. This could be resulted in a more favourable position in the tender announcement through quantity increase of claims arisen in one transaction by competing the participants in the supply position.

The information system, which substitutes effects of large-scale plant and the self-learning structure provide that the solutions described in our model provide an intensive development path for the agriculture.

The alteration in the online-marketplace and interests could be seen on Figure 1.



**Figure 1** The online-marketplace and interests (based on: Magó and Fenyvesi, 2009, own editing)

## RESULTS

### *Elaboration of the procurement and sales competition supporting producers*

Central element of development is the database, which is the basis of the online-market place. For users (producers) the market field collects proposals as well as helps to write procurement tenders and sales tenders, hence it fosters competition of suppliers and purchasers. Producers can achieve more favourable positions by this system in terms of procurement price level, quality and other product qualities regarding their input materials (technical systems, chemical materials, biological products).

Despite the fact that participants in the supply market will compete with each other, they will have also advantages since supply market of the input products provided by them will be more transparent also for them and can be planned in an easier way and specification of participants in the market will be more simply. Therefore, efficiency of their trade will increase.

Number of participants in the supply can gradually increase since the system expects new members. As a consequence, competition can increase, number of products in supply can increase and their quality features improve.

### *Advantages realized by participants of the online-marketplace*

By using the “online-marketplace”, it will be the producers on the first place who will have advantages since their agriculture can be planned in an easier way and can be transparent. Besides the faster information flow, they can achieve decrease in their cost. Quality assurance and standardization guarantee utility and marketing of quality products.

**Table 1** Advantages realized by participants of the online-marketplace

<b>Benefits</b>	
From the viewpoint of <b>distributors</b>	Plannable input claim, demand supply balance More efficient trade
From the viewpoint of <b>farming</b>	Plannability Transparency Cost reduction From the view of input output quality assurance, standardisation Fast information flow
Stimulation of <b>cooperation</b>	Forming of common machine usage forms, machine circles Development of modern technological solutions, introduction More efficient appearance into loan offices' direction Global market information Common logistical solutions
From the viewpoint of concerned <b>authorities, government, market players, experts, R&amp;D&amp;I</b>	Forming of a regional informational system Accurate data from the use of the inputs (qualitative, quantitative features, temporal) Statistics to the subsidy-, aid systems, market forecasts, (crop estimation based on inputs and a sowing construction) Registration of expenditures, realizations Optimisation of EU and national subsidies

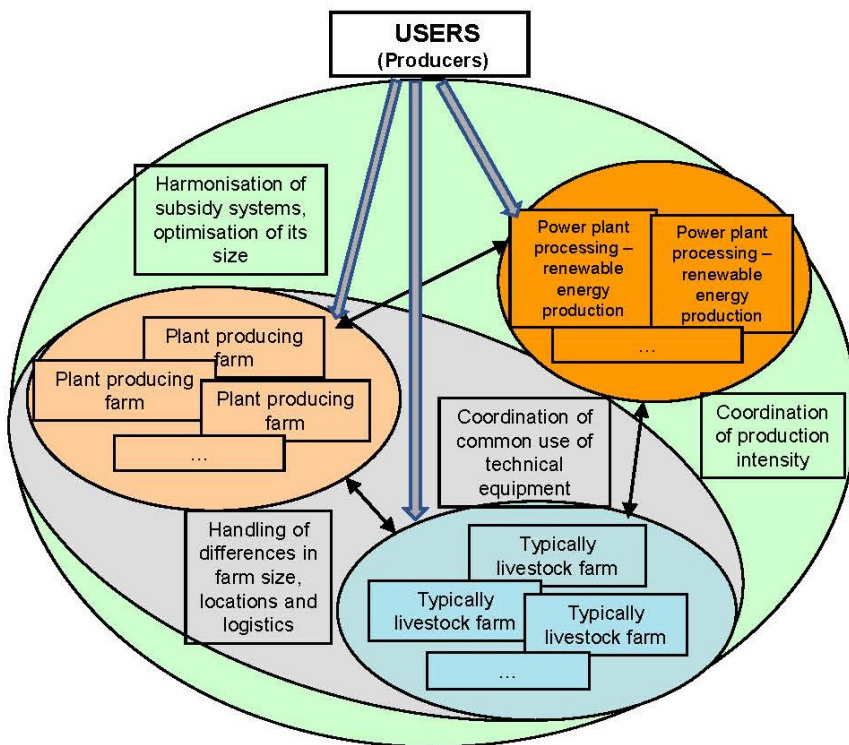
By inducing this system, cooperation among producers will be fostered. Creation of common utility forms of machines and machine types can increase efficiency regarding machine procurement and utility of machines. Cooperational solutions foster use of results achieved due to modern technological solutions. Apart from production devices, access to money assets can be improved. The method how to obtain market information can be developed, as well. Also a common logistical solutions could be improved.

Besides producers and distributors, the system provides advantages also for the government, authorities, experts and other participants of the R+D+I market.

A field informatics system can be accomplished by which we could get an exact picture and data about utility and time-quality-quantity features of inputs. Collection of data can be provided for the supportive market forecast systems (estimation of production on the basis of structure of inputs and products). It can contribute to optimization of the national and the EU subsidies.

Structure of costs and marketing can be monitored at traders and producers implied in the system.

In the Table 1 we can follow the benefits of the usage of online-marketplace.



**Figure 2** Structure of participants in the online-marketplace  
(source: Magó and Fenyvesi, 2009, own editing)

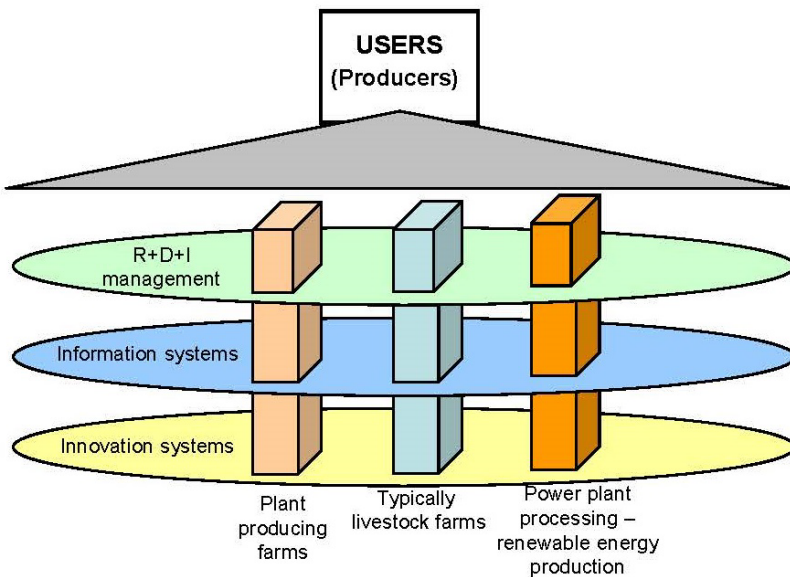
***Structure of participants in the market field***

Considering structure of users (producers), they can belong to different branches. Plant production and livestock farms can be emphasized (these can be also mixed plant production and livestock farms). The energy plant process factories using products of plant production

agriculture produces energy out of agricultural renewable materials. By using the system, these factories can enter by their claims regarding input materials for procurement while they are interconnected no matter where they are located or how big or small they are. Cooperation can extend to harmony concerning common utility of technical devices as well as accomplishment of a more effective access to money assets. Coordination of intensity regarding production can be accomplished on a higher, more comprehensive level by participation of more producers. Moreover, harmony of supportive systems and their optimization in accordance with their different stimulating measures could be more accurate and deeper professionally. (Figure 2.)

### *The system covering participants of the online marketplace*

The information system that is going to be established stimulate users (producers) to cooperate with each other. It provides conditions of effective information flow by covering all of the users. It provides a common base for application of innovation systems. Coordination of R+D+I tasks can be accomplished mutually by covering a bigger production structure. (Figure 3.)



**Figure 3** The system covering participants of the online-marketplace  
(source: Magó and Fenyvesi, 2009, own editing)

## CONCLUSIONS AND RECOMMENDATIONS

Agricultural production has been carried out to a great extent by small-middle enterprises and farmers. These enterprises and farmers can accomplish concentration necessary for obtainment of market advantages very hard. Therefore, such a system is necessary, which can coordinate and keep in touch with producers and is self-assertive in an effective way.



By the model of a market field, which can be considered a trade and production system in agriculture and its aims take the following stipulations into consideration, so the characteristics of users in the market field should be (Magó and Fenyvesi, 2009):

- We consider producers autonomous and equal people/organizations, which could have the best situations to make decisions. We do not restrict their decisions about production.
- Market relations are a key element and activities as well as production have to meet the requirements set by the market.
- The system has to meet the market and all of the stipulations arisen during its operation, such as environmental regulations and support. These stipulations determine conditions of operation instead of the system of operation.

The system should foster the producers, should foster more successful production and must not restrain them. Hence it should provide market advantages at all of the elements of the production (regardless the size of property and production system). As a consequence, a real solution could be made for practical development of agriculture by increase of suppliers' competition situations.

## REFERENCES

- Balogh Cs. (2012). A fejlesztés lehetséges útja. Magyar Mezőgazdaság, Vol. LXVII, No. 40. p. 22-25.
- Baranyai Zs., Takács I.: (2007) Factors of Cooperation in Technical Development of Farms in Hungary, *Annals of the Polish Association of Agricultural and Agribusiness Economists*, 9: (1) p.18-22.
- Etro F. (2021). Product Selection in Online Marketplaces. *Journal of Economics & Management Strategy*, Vol. 30, pp. 614– 637. <https://doi.org/10.1111/jems.12428>
- Fieldsend F. A. (2020). Agricultural Knowledge and Innovation Systems in European Union policy discourse: Quo vadis? *Studies in Agricultural Economics* Vol. 122, No 3. p. 115-123. <https://doi.org/10.7896/j.2055>
- Kawecka-Wyrzykowska, E. (2020). Assessment of the European Commission's proposals for financing the EU budget in 2021–2027 *International Journal of Management and Economics*, Vol. 56, No.3, p. 193-208. <https://doi.org/10.2478/ijme-2020-0018>
- Koester, U. (2020). *Foundations of Agricultural Market Analysis and Agricultural Policy* Vahlen Textbooks, Verlag Franz Vahlen GmbH, Munich, Germany, 439 p.
- Kusumawati R. D., Oswari T., Yusnitasari T., Dutt H. (2022). Analysis of Marketing Mix and Website Performance on E-marketplace of Agricultural Products. In: Fong, S., Dey, N., Joshi, A. (eds) *ICT Analysis and Applications. Lecture Notes in Networks and Systems*. Springer, Singapore. Vol. 314. p 437–444. [https://doi.org/10.1007/978-981-16-5655-2\\_42](https://doi.org/10.1007/978-981-16-5655-2_42)
- Magó L. (2007). Models showing increase in cost efficiency of mechanisation on small and medium sized arable farms. *Tractors and Power Machines*, Novi Sad, Serbia. Vol. 12. No. 2., p. 54-61.
- Magó L. (2009). „The Review of the Features of Machine Utilization in Field Crop- and Vegetable Farming and Plantation Cultivation”, *Proceedings of the 37<sup>th</sup> International Symposium “Actual Tasks on Agricultural Engineering”*, Opatija, Croatia, 10-13. February 2009. Proc. p. 291-301.
- Magó L., Fenyvesi L. (2009). *Work Plan of the National Technology Program Project Proposal “Increase of Competitiveness Concerning Agricultural Production through Competitive Input Market Field and an Innovation System”* Budapest-Gödöllő. 49 p.

- Nagy I., Magó L. (2004). Machinery Development Alternatives in Agriculture Based on Farmers Cooperation, Olympics of Agricultural Engineering, Collection of Extent Abstracts of the 2004 CIGR International Conference-Beijing, China. 11-14 October 2004. Vol. 2. p. V-15.
- Nagy I. (2007). Cost Saving Machinery Using and Farmers Helping Cooperations in the Agriculture. Tractors and Power Machines, Novi Sad, Serbia. Vol. 12. No. 2., p. 102-107.
- Schnicke, H. J. (2011). The Impact of Demographic Patterns in Hungarian Farm Households on Structural Change In: Möllers, J. – Buchenrieder, G. – Csáki Cs. (edit.) Structural Change in Agriculture and Rural Livelihoods: Policy Implications for the New Member States of the European Union Leibniz Institute of Agricultural Development in Central and Eastern Europe, Studies on the Agricultural and Food Sector in Central and Eastern Europe, Vol. 61. p. 263
- Szabó G. (2000). A szövetkezeti vertikális integráció lehetőségei a magyar élelmiszer- gazdaságban, Szövetkezés, 21 (1-2), 30-42.
- Szabó G. (2011). Szövetkezetek az élelmiszer-gazdaságban, Agroinform Kiadó, Budapest, p. 255
- Széles Gy. (2003). Az integráció üzemgazdasági összefüggései, Gazdálkodás, 47 (4), 28-36.
- Takács I. (2001). A gép- és gazdaságsegítő körök szerepe a kooperációban és koordinációban. In VISION 2000 III. A kooperáció, a koordináció és az integráció szerepe és lehetőségei az agrár és a vidéki gazdaságban. Konferencia kiadvány II. kötet. Gödöllő. p. 146-155.
- Takács I., Baranyai Zs. (2010). Role of Trust in Cooperation of Farmers from the Aspect of New Institutional Economics, Annals of the Polish Association of Agricultural and Agribusiness Economists, 12: (6) p. 179-184.
- Tardos J., Sári E. (edit). (2003). IKR Bábolna 1973-2003. IKR Rt., Bábolna, 54 p.
- Teuteberg F. (2020). E-Marketplace-Modelle. In: Kollmann, T. (eds) Handbuch Digitale Wirtschaft. Springer Gabler, Wiesbaden. pp 569–601. [https://doi.org/10.1007/978-3-658-17291-6\\_44](https://doi.org/10.1007/978-3-658-17291-6_44)
- Tot A., Nikolić R., Radić P. (2018). Agricultural Cooperatives and Engineering Associations Aiming at Developing Agriculture. Tractors and Power Machines, Novi Sad, Serbia Vol. 23, No. 5., p. 51-55.
- Tóth E. (2000). Az átalakult mezőgazdasági szövetkezetek gazdálkodásának főbb jellemzői (1989-1998), Agrárgazdasági Kutató Intézet, Agrárgazdasági Tanulmányok, No. 11., p. 114
- Yuan G. (2022). Technology and Disintermediation in Online Marketplaces. SSRN. 59 p. <http://dx.doi.org/10.2139/ssrn.4150094>
- Walenia A. (2022). Sources of Financing Sustainable Agriculture and Rural Areas in the EU in the Financial Perspective of 2021-2027. VUZF Review, 7 (1), 80-87. <https://doi.org/10.38188/2534-9228.22.1.08>



## THE USE OF GAUGE R&R METHOD IN MANUFACTURING OF AGRICULTURAL MACHINERY

Bogdan Raul MIRCEA, Rudolf MIRESCU, Dumitru TUCU\*

\*E-mail of corresponding author: [dumitru.tucu@upt.ro](mailto:dumitru.tucu@upt.ro)

*Mechanical Machines and Transportation, Politehnica University Timisoara,  
No.1, Mihai Viteazu Av., RO-300011 Timisoara, Romania*

### ABSTRACT

*In the manufacturing of agricultural machinery process, the most important work is measurement of parts, especially for quality assurance. Actual trends require management to be able to make decisions based on proper quantitative analysis of data in the context of advanced manufacturing and data processing. Such actions can improve the quality of the data if measurement system presents sometimes errors. The paper presents an application of the Gauge Repeatability and Reproducibility (R&R) method in a medium-sized company from Arad County, Romania, specialized in manufacturing of agricultural machineries for soil, weed control and other treatments. The concrete application referees to the height measuring device. 10 pieces, numbered from 1 to 10, were measured by three operators, three times. All data were collected according to characteristics to be measured in tests Gauge R&R files. All tests were run according to methodology in next steps: explaining to each operator how to make the measurements with the device according to the work instructions; performing of measurement three times each operator; observation and monitoring of the process (equipment, conditions, procedure etc.). The collected data were introduced in the Minitab computer system in condition of creating the system able to perform the graphs relevant to the Gauge R&R. The measurements performed were validated, by analysing the variations that appear between operators or between some measurements, the observer of these measurements giving the analysis team all the notes during the measurements (external influences, interventions (telephone, breaks), etc.). Finally, analyse provide other numerical data that help to identify the status of the performed testing. Due to complexity of parts and systems used in agricultural machinery, the proposed method is highly recommended to avoid misleading conclusion regarding measurement process.*

**Keywords:** *Gauge Repeatability and Reproducibility, manufacturing process, measuring, correction actions, optimization*

## INTRODUCTION

In all manufacturing process, the measurement system analysis (MSA), realize the rigorous assessment of measurement accuracy and precision (Saupi and Midi, 2021). Relatively Life Cycle of the product, especially agricultural machinery impose as the most important aspects reproducibility (the variation in the operating system which is caused by differences between operators) and repeatability (variation in the operating system due to operating device) (Babanatis et al., 2018; Tucu, 2012). In principle, a Gage R&R study can employs a lot of mathematical methods as: fuzzy methods (Tucu et al., 2010), robust regression method (more reliable than classical least squares method), (Rashid et al., 2021), statistical behaviour of residuals for detecting outliers in a two-way table (Gentleman and Wilk, 1975), Modified Large Sample (MLS) and Generalized confidence intervals (GCI) (Burdick et al., 2005), different measurement systems for using the Heckel and Ryshkewitch-Duckworth models for characterizing materials (Hernandez et al., 2021), etc. Such methods must cover all requirements regarding quality standards (ISO 9001-2015 Quality Management International Standard, IATF 16949-2016 Quality management system requirements for automotive production and relevant service parts organizations, etc. (Celano, 2022)). Also, the process for assessment creative engineering design by evaluating of reliability and generally the process, needs the use of gauge R&R (Morin et al., 2017). In SMEs for manufacturing agricultural machinery a gage R&R study can help to determine whether the measurement system's variability is small compared with the process variability, the measure of variability caused by the operators, and whether the measurement system is capable of discriminating between different parts. Due the disparities regarding perception of motivational factors for quality, especially in enterprises for manufacturing agricultural machineries such measurement is necessary (Tucu et al., 2021). Usually the application of gauge R&R method is necessary to employ Analysis of Variance (ANOVA) for analyse the variation associated with each component, and subsequently further analysis carried out to determine whether or not measurement system precision can be acceptable. The measurement system is considered acceptable, marginal and not acceptable, if the variation of Gage R&R is less than 10%, between 10-30% and greater than 30%, respectively. (AIAG, 2010; Dhawale and Raut, 2013).

The main objective of the paper was to assess and validate the measurements performances in a SME specialized in manufacturing of agricultural machineries, by analysing the variations that appear between operators or due to equipment, for one family of pieces. Finally, analyse provide other numerical data that help to identify the status of the performed testing. Due to complexity of parts and systems used in agricultural machinery, such proposed method can be recommended to avoid misleading conclusions regarding MSA.

## METHODS

The experiment was done in a Romanian production plant specialized in the manufacture of machines for minimum tillage: subsoilers, seedbed cultivators, disc harrows and stubble cultivators, situated in Chisineu Cris, Arad County, west of the country and consist in measuring of one high. The steps in experimental setup (workflow) are presented in figure 1 and supposes: Step 1. Picking up the parts for testing. 10 pieces were taken to be tested by 3 operators, each operator having to test each piece 3 times; Step 2. Marking of parts/numbering. Each piece was numbered from 1 to 10 in an area where the operator had no

visual access; Step 3. Gage R&R test planning/preparation; Step 4. Running the Gage R&R test; Step 5. Inserting the collected data into the Minitab computer system. The environmental conditions during the testing were in accordance with the requirements of the laboratory procedure, the temperature being 23.1°C and the humidity 54%. The measuring procedure testing started on 06/07/2022 at 1:45 p.m., ending the same day at 2:50 p.m. The flux diagram is presented in figure 2.

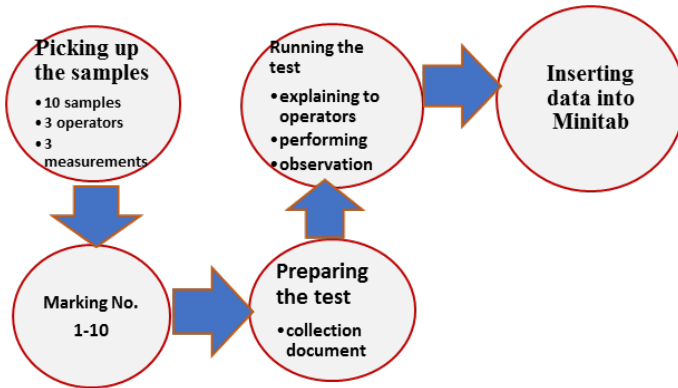


Figure 1 Experiment workflow

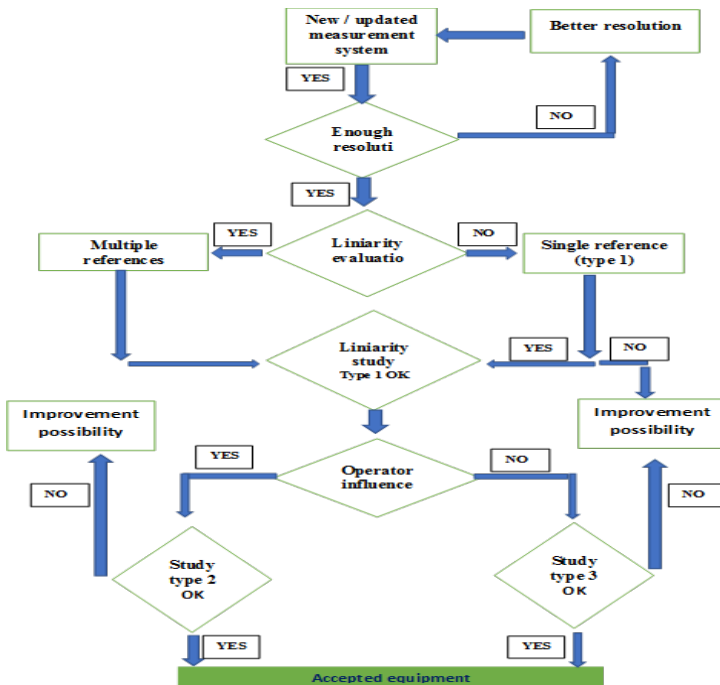
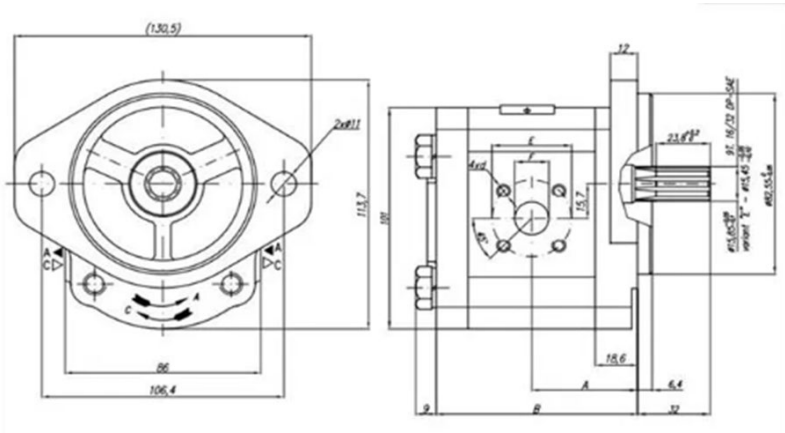


Figure 2 Flux diagram

The parts design is presented in figure 3.



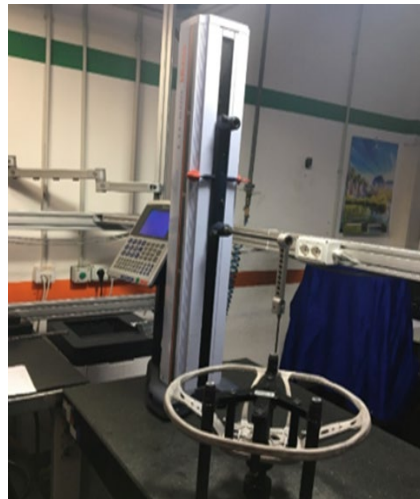
**Figure 3** Parts design

All measurement took place on a measurement machine 3D Axiom too HS 600 (640 x 600 x 500 mm), using Aberlink 3D measurement software & Minitab. The machine was equipped with 0.0001 mm linear encoders for superior precision, Renishaw TP8 measuring head and standard joystick having the possibility of choosing the size of the Y axis from 600 mm to 1500 mm.

In figure 4 are presented the marked sample (a), and position of measuring (b).



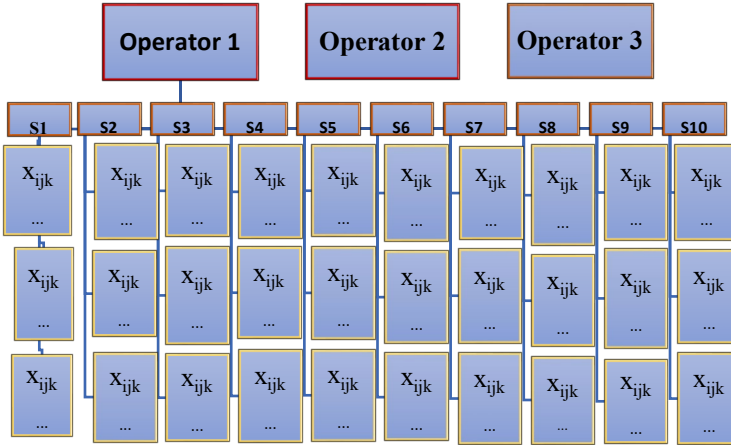
a



b

**Figure 4** Marked sample no.1 (a) and measuring process (b)

The testing plan is presented in figure 5, where  $x_{ijk}$  is the measurement results (values) corresponding to operator  $i$  ( $i=1 \dots 3$ ), part  $j$  ( $j=1 \dots 10$ ) and replication  $k$  ( $k=1 \dots 3$ ).



**Figure 5** Nested Gage R&R study for validation of height measurement

Each measurement is represented according to the next model:

$$X_{ijk} = \mu + O_i + P_j + (OP)_{ij} + R_{k(ij)} \begin{cases} i = 1, 2, \dots, o \\ j = 1, 2, \dots, p \\ k = 1, 2, \dots, n \end{cases}$$

where, the constant  $\mu$  represents the average of the observations,  $O_i$ ,  $P_j$ ,  $(OP)_{ij}$  and  $R_{k(ij)}$  are random variables representing the effects of the Operators, measured Parts, the Operator-Part interaction, and the replicates of the measurement respectively. To analyze the model, it is assumed that the terms  $O_i$ ,  $P_j$ ,  $(OP)_{ij}$  and  $R_{k(ij)}$  have average value of zero (implying that the measurement system is objective) and that the variance components is constant; furthermore, the model also assumes that the measurement is linear for the  $P_j$  terms,  $(OP)_{ij}$  and  $R_{k(ij)}$ , so that with these assumptions, the statistical analysis consists of an analysis of variance (ANOVA). The variability of the measurement process ( $\sigma^2$ ) is defined as the variability of the repeatability coupled with reproducibility:

$$\sigma^2_{gauge} = \sigma^2_{repeatability} + \sigma^2_{reproducibility}$$

To determine the contribution of each source of variation, it is necessary to quantify the component of the variance contributed and subsequently express it as a percentage of contribution. The data was recorded in a table generated automatically in the computer system, according to the wishes of the person performing the test. This also includes the order of measuring the parts during the testing of the 3 operators in the laboratory. After testing all 3 operators, test conditions are created in the system to be able to perform the graphs relevant to the GAGE R&R test. The measurements performed can be validated after analyzing the

large variations that appear between operators or between some measurements, and the observer of these measurements gave the analysis team all the notes during the measurements (external influences, interventions (telephone, breaks)). The results permit to identify the status of the performed testing. The acceptance of the results is based on the percentage of errors identified by the operators: if variance <10% - Accepted measurement system – it is mainly used for sorting and classification operations; if variance is between 10-30% - Can be accepted under some conditions - Can be used to assess repair and rework costs; if variance is >30% - It is unacceptable – Urgent measures must be taken to restore the system. The method used for analyzing these results was VDA-QMC (03/20/16) TYPE2 – ANOVA (tolerance).

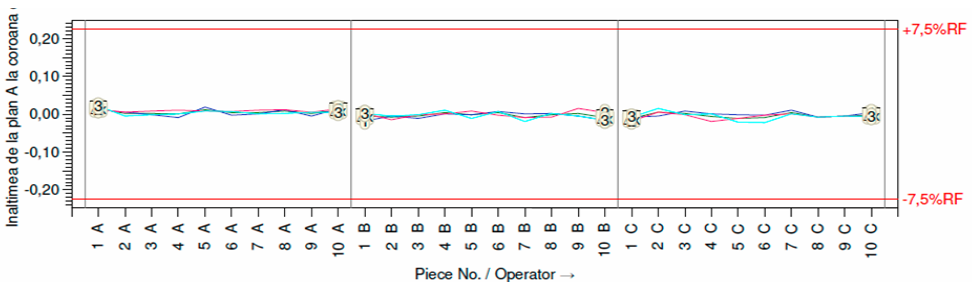
### RESULTS AND DISCUSSION

In table 1 are presented the results of measurements, where OP1, OP2 and OP3 are the operators (i=1...3); Piece1 to Piece 10 are the parts (j=1...10); A,B,C are replication (k=1...3).

**Table 1** Results of measurement

	Piece 1			Piece 2			Piece 3			Piece 4			Piece 5		
	A	B	C	A	B	C	A	B	C	A	B	C	A	B	C
OP1	89.68	89.66	89.67	89.85	89.45	89.37	89.75	89.67	89.67	89.64	89.63	89.61	89.64	89.66	89.68
OP2	89.63	89.61	89.79	89.79	89.47	89.25	89.77	89.64	89.68	89.68	89.65	89.63	89.68	89.67	89.61
OP3	89.65	89.63	89.69	89.63	89.41	89.35	89.64	89.65	89.63	89.67	89.73	89.62	89.64	89.68	89.62
	Piece 6			Piece 7			Piece 8			Piece 9			Piece 10		
	A	B	C	A	B	C	A	B	C	A	B	C	A	B	C
OP1	89.69	89.64	89.45	89.65	89.45	89.85	89.95	89.42	89.35	89.45	89.56	89.55	89.45	89.64	89.73
OP2	89.71	89.74	89.51	89.75	89.43	89.83	89.67	89.43	89.45	89.35	89.47	89.51	89.47	89.67	89.61
OP3	89.75	89.64	89.75	89.15	89.54	89.75	89.95	89.45	89.33	89.51	89.49	89.54	89.44	89.95	89.67

The results obtained after inserting the data into the Minitab computer system is presented in figure 6.



**Figure 6** Results of measurements after Minitab processing



As expected, the measurement differences between the operators are not large, all three operators measured almost identically (figure 7), because they have accumulated experience in the company's measurement laboratory over time.

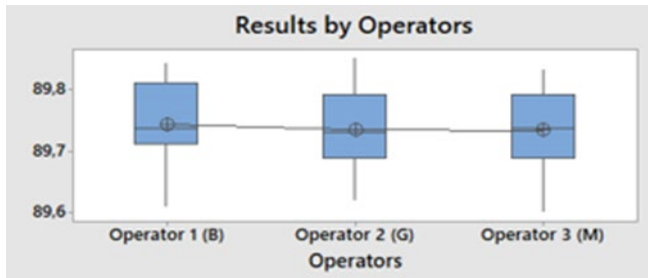


Figure 7 Differences between operators measuring

In figure 8 is presented the results of measurements performed by each operator.

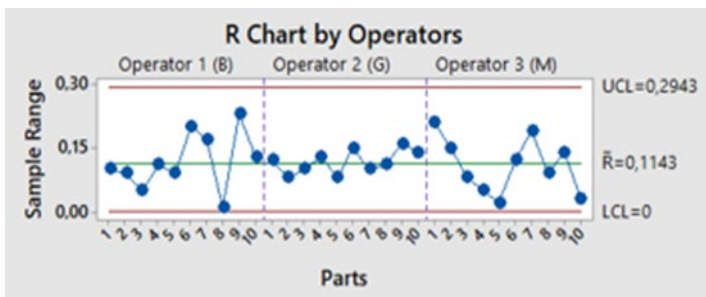


Figure 8 Measurements performed by each operator

The completely statistical results are presented in figure 9 and permit to identify and validate the status of the performed testing.

Regarding the data above, it can evaluate the result as good, the value being below 10%, which means that the measurement system is accepted. An important parameter in the notions of statistics is the "number of distinct categories" which tells us important data about the selection criterion of the samples to be tested in the study. A number greater than 5 tells that they were chosen accordingly. In the present case, this number is 9, so a very good selection of these parts was made.

	Variance	Standard dev.	Confidence inter	1- $\alpha$ = 95.000%	
Repeatability	0.000058889	0.0076739	EV =0.0065129 ≤ 0.0076739 ≤ 0.0	%EV = 1.02%	
Reproducibility	0.000027037	0.0051997	AV =0.0015405 ≤ 0.0051997 ≤ 0.0	%AV = 0.69%	
Uncertainty from inter	0.000025926	0.0050918	IA =0.0018235 ≤ 0.0050918 ≤ 0.0	%IA = 0.68%	
Repeatability & Reprc	0.00011185	0.010576	GRI=0.0094246 ≤ 0.010576 ≤ 0.03	%GRR = 1.41%	
Part Variation	0.0045843	0.067707	PV =0.039434 ≤ 0.067707 ≤ 0.130	%PV = 9.03%	
Total Variation	0.0046961	0.068528	TV = 0.07		
Design			Reference Figure		
No. of Trials	=	3	Process Variation	=	0
Number of operators	=	3	Tolerance	=	3.00
Number of Parts	=	10	required Cp value	=	
Resolution	%RE	=	0.33%		
number of distinct categories	ndc	=	9		
Repeatability & Reproducibility	%GRR	=	1.41%		
Minimum reference figure for capable measur-		$T_{min} (\%GRR)$	=	0.282	
Minimum reference figure for measuring syste-		$T_{min} (\%GRR)$	=	0.141	
Measurement system capable (%RE,min,%GRR)					
⊗ VDA-QMC (03/2016): Type 2 - ANOVA (tolerance)					

Figure 9 Print Screen of statistical results

### CONCLUSIONS

The article proposes and demonstrate the importance of the use of modern methods for quality insuring and improvement in agricultural machinery manufacturing, by proposing a diagnostic and validation method for identifying and correction of risks in quality management. Such methods, already used in other field of manufacturing, can give high performance to the process of manufacturing agricultural machinery, also for extending the concept „industry 4.0“. Authors consider the method is highly recommended to identify the measurement failures and weak points. For extending the use of method in small enterprises from agriculture future efforts of authors will be focused to edit a simple guide.

### REFERENCES

Babanatis Merce, R.M., Babanatsas, T., Maris, S., Tucu, D., Ghergan, O.C. (2018). Study of an automatic olives sorting system. In: Actual Tasks on Agricultural Engineering, Zagreb, Vol. 46, 485-490

Burdick, R.K., Borror, C.M., Montgomery, D.C. (2005). Design and Analysis of Gauge R&R Studies. ASA-SIAM.

Celano, G. (2022). A bootstrap method for the measurement error estimation in Gauge R&R Studies. Qual Reliab Engng Int. 38, 3404–3421

Dhawale, M. R., Raut, D. N. (2013). Evaluating measurement capabilities by gauge R&R using ANOVA for reliability. System, 3(3), 1143–1148

Gentleman, J. F., Wilk, M. B. (1975). Detecting outliers in a two-way table: I. statistical behaviour of residuals. Technometrics, 17(1), 1–14

Hernandez, O.C., Rodriguez, I.C., Bernad, M.J.B., Contreras, L.M.M. (2021). Design of crossed and nested Gauge R&R studies for the validation of the Heckel and Ryshkewitch-Duckworth mathematical models. Ars Pharmaceutica 62(2), 190-202

- Morin, S., Bourdeau, L.-M., Robert, J.-M. (2017). Using the Gage R&R method to evaluate the reliability and assessment process of the creative engineering design assessment. *TPM* 24, 499-514
- Rashid, M. A., Midi, H., Dhhan, W., Arasan, J. (2021). Detection of outliers in highdimensional data using nu-support vector regression. *Journal of Applied Statistics*, 1–20. <https://doi.org/10.1080/02664763.2021.1911965>, accessed June 2022
- Saupi, A.A., Midi, H. (2021). Outlier Detection Method in Crossed Gage Repeatability and Reproducibility (R&R) Random Effect Model. *Malaysian Journal of Mathematical Sciences* 15(3), 333–345
- Tucu, A., Crisan, G.C., Tucu, D., Vasilica, A. (2021). Motivational factors in systems of occupational risk management in agriculture. In: *Actual Tasks on Agricultural Engineering, Zagreb, Vol. 48*, 521-526
- Tucu, D. (2012). Application of Life Cycle cost method for willow production machinery. In: *Actual Tasks on Agricultural Engineering, Zagreb, Vol.40*, 549-556
- Tucu, D., Golimba, A.G., Slavici, T. (2010). Fuzzy methods in renewable energy optimization investments. In: *Proceedings of 38th International Symposium on Agricultural Engineering (ATAE 2010), Actual Tasks on Agricultural Engineering, Zagreb, Vol. 38*, 455-462
- \*\*\*, AIAG. (2010). *Measurement systems analysis - reference manual*. 4th ed. Chrysler, Ford, General Motors Supplier Quality Requirements Task Force, Southfield, Michigan

---

---



## SMALL BIOGAS PLANTS IN SERBIA - PREREQUISITES FOR PROFITABILITY

Djordje DJATKOV\*, Aleksandar NESTEROVIC, Miodrag VISKOVIC,  
Milan MARTINOV

\*E-mail of corresponding author: djordjedjatkov@uns.ac.rs

University of Novi Sad, Faculty of Technical Sciences, Chair of Biosystems Engineering,  
Trg Dositeja Obradovica 6, 21102 Novi Sad, Serbia

### ABSTRACT

*The typical small biogas plant is one that uses 9,000 t a<sup>-1</sup> of liquid manure of 500 cattle units (CU) for biogas production and has an electrical output of around 75 kW. Although small biogas plants have multiple advantages (methane mitigation, improved manure disposal & logistics, new income in rural areas, decentralized energy generation, etc.), there are no such plants in Serbia so far since they are not supported by actual policy, and they face multiple challenges. The objective of this study was to investigate under which conditions the construction and operation of small biogas plants could be profitable in Serbia. They require a high price for the delivered electricity in the grid, which rate at least 12.8 c€ kWh<sup>-1</sup> or 24.0 c€ kWh<sup>-1</sup>, for financing either from own finances or from bank loan, respectively. Accumulated equities after the project duration could facilitate the new investment in similar or other renewable energy projects. Utilization of surplus heat energy from small biogas plants and delivered to neighboring consumers is economically feasible if at least one third of heat energy is marketed. Results from this research could serve to the decision makers from the relevant field in Serbia to adapt appropriate relevant policy and enable implementation of such technology in Serbia.*

**Keywords:** manure, small farm, biogas, profitability, Serbia

### INTRODUCTION

“Small biogas plants” in this paper are defined as installations on smaller farms that predominantly use livestock manure and where the produced biogas is utilized on site for combined electricity and heat generation. Low-tech installations that use organic waste and

excrements from individual households, widespread in rural areas (Roubik and Mazancova, 2020; Singh and Kalamdhad, 2022; Lohani *et al.*, 2021), are not addressed. In such cases, the biogas is directly used for cooking, lighting, or heating. In Germany, the country with the most developed biogas technology and number of facilities, as well as the biogas production from agricultural sector, small biogas plants were first defined as installations that use a minimum share of 80% animal manure on a fresh-matter basis in the input and operate a generator with a nominal electric power output of up to 75 kW (BMW, 2014). Based on these specifications, they are legally qualified to obtain a guaranteed tariff for grid feed (“feed-in” tariff) of their electricity output, as the basis for profitability. The biogas that can be produced from the liquid manure of 100 cattle units (CU) is sufficient to produce about 15 to 18 kW electric power output. Accordingly, a biogas installation sized for an output of 75 kW, requires about 500 CU, excluding by-products or wastes from agriculture and food-processing as additional input materials for biogas production. In Serbia, small biogas plants with an output of 75 kW are neither defined nor supported as a separate category within the existing and planned legislation on renewable energies (MMERS, 2014a; 2014b; 2021).

In Germany, 9,527 biogas plants operated as of 2019, with a total capacity of 5,000 MW electrical power output (EBA, 2021; FvB, 2021). Thus, about half of all biogas plants in Europe are currently located in Germany. However, the 520 installations with an electric power output of up to 75 kW and an additional 430 installations of up to 150 kW, small biogas plants are the minority (BNA, 2021a). More than one third of small biogas plants are located in Bavaria. Overall, less than 30% of total livestock manure in Germany is supplied to biogas plants (Scholwin *et al.*, 2019), and animal manure remains unused particularly on small farms. In Serbia, 22 biogas plants operated as of 2019, with a total installed electric capacity of 21.21 MW (EBA, 2021). Most of these have an electric power output of around 1 MW, a few with 500 to 650 kW, and one with 200 kW (MMERS, 2020). Together, these plants used around 175,000 t a<sup>-1</sup> of liquid manure equivalent, which is less than 1% of the total livestock manure potential in Serbia (SORS, 2021). Thus, the overall share of animal manure that is properly treated in Serbia is negligible so far, and on small farms it is zero.

Livestock manure is used mostly as an organic fertilizer on agricultural land, but the current management practices cause significant environmental pollution and a threat to public health. If it is applied to agricultural land in excessive amounts, it can contaminate water resources and result in detrimental effects on soil. The handling and storage of manure is recognized as a significant source of GHG emissions, directly in the form of methane (CH<sub>4</sub>) and indirectly in the form of nitrous oxide (N<sub>2</sub>O) after application to agricultural land. Globally, emissions of non-CO<sub>2</sub> GHG from agriculture amount to about 5.5 Gt CO<sub>2eq</sub> per year or 11% of total GHG emissions (Edenhofer *et al.*, 2014), of which a significant portion originates from manure management. In Serbia, direct GHG emissions from manure management contribute 35% to the total emissions from animal husbandry (MEPRS, 2017; Viskovic *et al.*, 2022). Therefore, a significant share of 30 million tons of manure from all livestock in Serbia should be managed in environmentally safe manner. As there are many family-owned farms with only a few up to a hundred CU (Viskovic *et al.*, 2022), the development of small biogas installations in Serbia for the sustainable use of manure represents a significant challenge.

Further financial and technological challenges are the following. A small biogas plant incurs high specific investment cost. In Germany, the average investment cost of a biogas plant with 75 kW of electric power output is 9,000 € kW<sup>-1</sup>, as opposed to an installation with

1,000 kW which incurs an average investment cost of 3,750 € kW<sup>-1</sup> (DBFZ, 2013). Operators can lower these investment costs to around 5,500 € kW<sup>-1</sup> for small plants by contributing significantly to the construction. At the same time, the efficiency of electricity generation is lower and rates up to 35%, compared to values of up to 44% for large generators (Stinner *et al.*, 2015). Thus, as small biogas plants incur more than double the specific investment costs and yield 20% less electricity than large biogas installations, electricity prices must be substantially higher for small biogas plants in order for them to be profitable. Accordingly, the special electricity price for small biogas plants is about 23 c€ kWh<sup>-1</sup> in Germany. For larger plants, the participation in a tender process (“Pay-as-bid”) with a current ceiling price of about 14.4 for existing plants and 16.4 c€ kWh<sup>-1</sup> for new installations determines the price (BNA, 2015). A similar system is introduced in Serbia (MMERS, 2021), however without any conducted procedures in practice yet. If substrates other than liquid manure are used (*e.g.*, energy crops, chicken manure, feed / crop residues, *etc.*), additional devices are needed for substrate pre-treatment and feeding / mixing of the digester. In such cases, the investment and operating costs are higher (Stinner *et al.*, 2015). This is a drawback, as a 75 kW plant that uses solely liquid manure requires a significant number of livestock (500 CU). Moreover, banks are mostly not willing to provide credit loans for such projects due to higher financial risks. Thus, for smaller farms, there are limited opportunities for profitable biogas production.

Small biogas plants generate environmental and socio-economic benefits. As the positive environmental effects were explained above, in this section it will be described how small biogas plants can benefit farmers and farm management. Primarily, a small biogas plant generates income for farmers through the sale of electricity. Exemplary calculations from Germany for biogas plants with electric power output of 75 kW that use solely liquid manure as substrate indicate a net annual income of up to 38,500 € (Stinner *et al.*, 2015). Due to the higher energy demand for heating the digesters, there is limited surplus heat available from small biogas plants for external uses, particularly during the cold season. Nevertheless, the heat output may be sufficient to replace the conventional heating of the farmhouse and farm buildings. Despite the low thermal power output of small biogas plants, most of the heat could be available for alternative uses in summer if this meets consumers’ capacities. At best, the biogas plant can be integrated into existing farm infrastructure. For example, the manure collection pit including pumps and pipes can be used to feed the biogas plant, while the holding tank for liquid manure can be used for digestate storage. The labor input for small biogas plants is rather low with no need to employ new staff. The average additional labor input for a small biogas plant is estimated at around 30 min per day (Stinner *et al.*, 2015).

The objective of this research was to investigate whether and under which conditions the implementation of biogas technology at small livestock farms could be profitable in Serbia. The motivation for this was the fact that small biogas plants that use liquid manure as substrate do not exist so far in Serbia, although they could contribute to several aspects of sustainability of rural areas. But such facilities could face multiple challenges comparing to medium and large sized biogas plants. The assumption was that produced biogas is to be used to generate electricity and optionally utilize at least certain share of heat energy. The objective of this study was to investigate under which conditions the construction and operation of small biogas plants could be profitable in Serbia. The main outcome is the needed minimal electricity price.

## MATERIALS AND METHODS

### Materials

#### Investigated scenarios

The eight investigated scenarios (Table 1) represent the different technical-technological configuration of small biogas plants. The purpose of defining and analyzing these scenarios is to investigate which configuration shows optimal results with respect to profitability. For that purpose, either cheap/inefficient or expensive/efficient combined heat and power units (CHPU) are distinguished. Further, digestate storage is considered either to be covered or uncovered, and additionally foreseen as concrete reservoir or lagoon in the ground. In all of the investigated scenarios, a plant uses liquid manure as sole substrate and has installed power of 75 kW<sub>e</sub>.

**Table 1** Investigated scenarios of small biogas plants

Scenario	Description
S1	CHPU advanced, Concrete digestate storage covered
S2	CHPU advanced, Concrete digestate storage uncovered
S3	CHPU simple, Concrete digestate storage covered
S4	CHPU simple, Concrete digestate storage uncovered
S5	CHPU advanced, Digestate storage- covered lagoon
S6	CHPU advanced, Digestate storage- uncovered lagoon
S7	CHPU simple, Digestate storage- covered lagoon
S8	CHPU simple, Digestate storage- uncovered lagoon

*CHPU: combined heat and power unit.*

#### Investment and operating costs of small biogas plants

**Table 2** Structure of the investment costs (Example: S1)

Investment cost	Value, €	Share, %
Digester & digestate storage	215,000	42.5
Cogeneration plant (CHPU)	160,000	31.6
Construction works & trench silo	38,000	7.5
Equipment	71,000	14.0
Non-material costs	20,000	4.0
Ramp-up	2,200	0.4
Total	506,200	100.0

*CHPU: combined heat and power unit.*



The example of the investment costs is given in the Table 2 and of the operating costs in Table 3, both for the scenario S1. Variance in other scenarios is that simple CHPU costs 50.000 €, whereby uncovered concrete digestate storage, covered and uncovered lagoon, cost 51.000 €, 54.400 € and 130.000 € less, respectively, all with the belonging equipment. These data were collected from technology providers and biogas plant owners in Serbia.

**Table 3** Structure of the operating costs (Example: S2)

<b>Operating costs</b>	<b>Value, € a<sup>-1</sup></b>	<b>Share, %</b>
Substrates (feedstock)	0	0.0
Maintenance	18,330	73.7
Energy & consumables	2,600	10.5
Labor	420	1.7
Insurance & other costs	3,500	14.1
Total	24,850	100.0

#### *Income of small biogas plants*

It was assumed that the price for the electricity fed into the grid should rate 23 c€/ kWh<sub>e</sub><sup>-1</sup> (similar conditions as in Germany). Other income, e.g. as for the surplus heat energy utilization is foreseen in the sensitivity analysis as well.

#### **Methods**

##### *Profitability assessment approach*

Profitability assessment was conducted by means of the calculator and decision-aid tool named BiogasPro, developed by the authors of this paper (Martinov et al., 2012). The assessment approach is in line with the parameters, criteria and rules of the Ministry of Energy and Mining of Republic of Serbia, defined in the guideline intended for planning and construction of energy facilities (Lepotic Kovacevic et al., 2010). The input data for the calculator are investment and the operating costs, as well as the income.

The three parameters and the assessment criteria in the Table 4 were used for the profitability assessment. If values of all three parameters satisfy defined criteria, the investment is considered to be economically viable, i.e. profitable. Net present value (NPV) here represents the net discounted income from the project cash flow. Internal Rate of Return (IRR) is the discount rate, for which the sum of net income from the project cash flow during the project duration is equal to the actual investment cost. The discount rate is calculated as the average weighted value of the interest rates of the total project financing sources (own resources and bank loan). In the case of financing from own resources the discount rate amounts 1% and in the case of bank loan of 100% of the capital costs it amounts 5%. The project duration is 15 years, according to the actual law and by-law documents in Serbia for renewable electricity producers (MMERS, 2021).

**Table 4** Parameters / criteria for profitability assessment (Lepotic Kovacevic *et al.*, 2010)

Parameter	Criteria for positive assessment
NPV	> 0
IRR	3 x higher than discount rate
PBP	Shorter than project duration

*NPV: Net present value; IRR: Internal rate of return; PBP: Payback period.*

### *Sensitivity analysis*

The sensitivity analysis with respect to the most relevant influencing parameters (operating parameters, additional income, sources and conditions of project financing, etc.) is performed as well. The financing from own resources and from bank loan was considered, whereby the criterion for achieved IRR should rate 3% and 15%, respectively. Beside this, the minimal needed price that allow for profitable operation is simulated in sensitivity analysis as well. The operating parameters reflect the possibility to utilize surplus heat, the remaining amount after heating the digester. The heat utilization rate from 10% to 50% of the produced annual amount was assumed. The scenarios S1 and S5 are selected to be investigated as advanced technological options with residual biogas collection and its utilization for electricity generation in the advanced CHPU. These are desirable scenarios with respect to opportunities to environmental protection, to avoid methane emissions and maximize energy generation from manure.

## RESULTS AND DISCUSSION

Profitability assessment results of the scenarios S1-S8, provided in the Table 5, simulate the influence of source of financing (own or bank loan). Only the scenario S1 does not show profitable operation when project is financing from bank credit. Accumulated equities after the project duration could rate up to approximately 920,000 € and 465,000 €, for the financing options, respectively.

**Table 5** Profitability assessment results

Scenario	NPV, €	IRR, %	PBP, a	NPV, €	IRR, %	PBP, a
	Own resources (DR=1%)			Bank loan (DR=5%)		
S1	871,255	16.25	5	398,518	14.03	5
S2	874,065	17.64	4	422,161	15.44	5
S3	813,607	18.36	5	404,710	16.21	5
S4	825,560	20.53	4	434,793	18.40	5
S5	922,954	18.47	4	458,039	16.28	5
S6	911,659	19.47	4	465,207	17.28	5
S7	865,306	21.39	4	464,231	19.27	5
S8	863,154	23.13	4	477,838	21.03	4

*NPV: Net present value; IRR: Internal rate of return; PBP: Payback period; DR: Discount rate.*

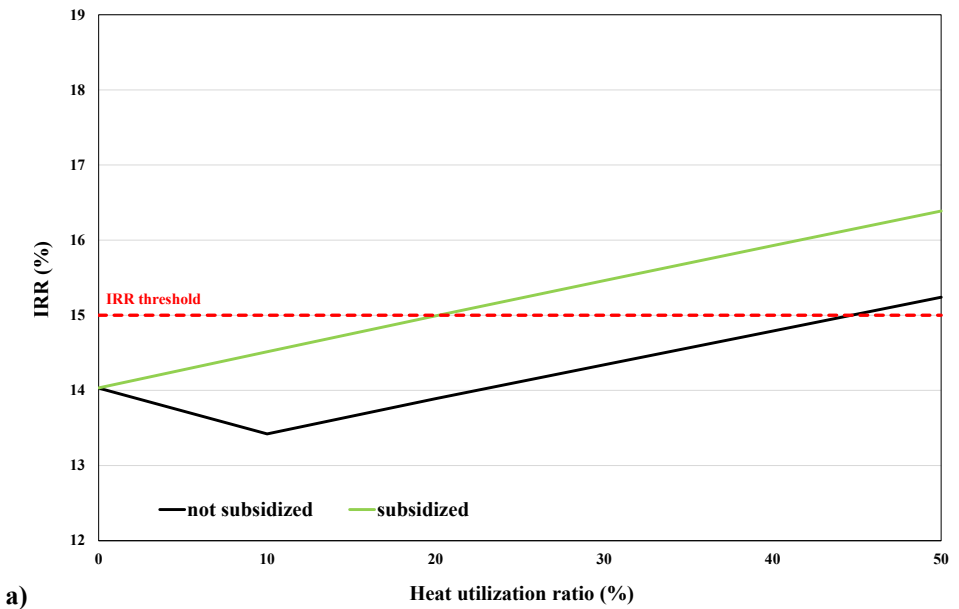
In the following Table 6 are presented results from the sensitivity analysis regarding the least (minimal) price of electricity fed into the grid that enable fulfilling the three profitability assessment criteria. Again, options of financing from own resources and from bank loan were considered, whereby the least electricity price should allow for IRR above 3% and above 15%, respectively. The required electricity price should rate at least 12.8 c€ kWh<sub>e</sub><sup>-1</sup> or 24.0 c€ kWh<sub>e</sub><sup>-1</sup>, for investing from own sources or from bank loan, respectively.

**Table 6** Sensitivity analysis– least electricity price for profitable investment

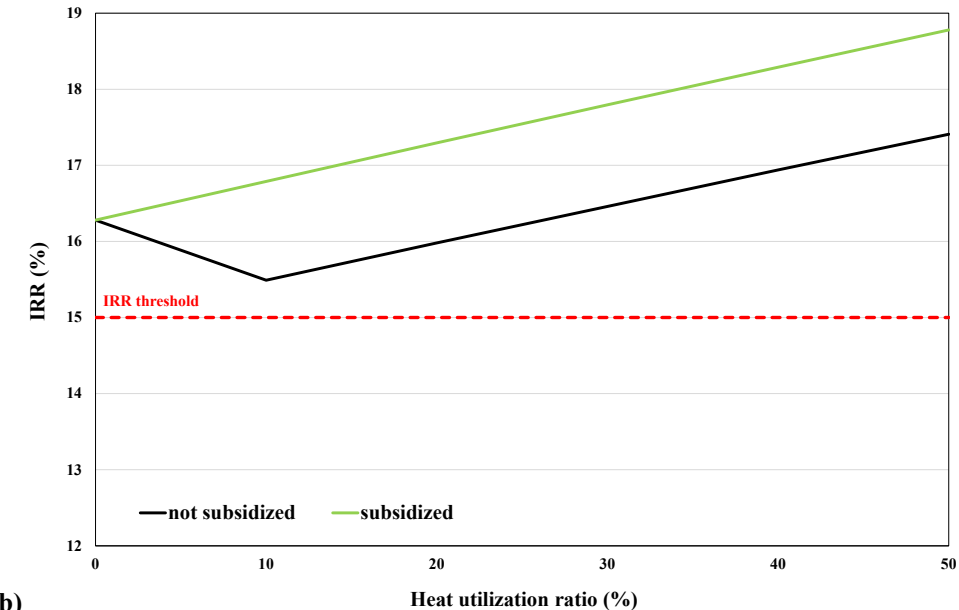
Scenario	Price, c€ kWh <sub>e</sub> <sup>-1</sup>	
	Own resources (DR=1%)	Bank loan (DR=5%)
S1	12.8	24.0
S2	12.4	22.7
S3	10.7	21.9
S4	10.0	20.0
S5	12.0	21.9
S6	11.8	21.2
S7	9.7	19.3
S8	9.3	18.1

*DR: Discount rate.*

The sensitivity analysis results regarding heat utilization in given in the Graph 1. It is conducted for the S1 and S5 (advanced technological options). Two cases for the investment of auxiliary infrastructure for heat utilization (heat exchanger, micro district heating pipeline) were considered, *i.e.* without and with subsidies *e.g.* from state or local government. Both scenarios subsume 100% financing from bank loan, as worse cases. The additional income through heat sale in the vicinity of a biogas plant for S1 could allow for profitable operation if more than 20% (with subsidies) or more than 45% (without subsidies) of produced heat is utilized. For S5, although both cases show profitable operation, the case without subsidies shows improved economic performance for heat utilization ratio of more than 30%.



a)



b)

**Graph 1** Sensitivity analysis– heat utilization ratio

a) S1; b) S5.

## CONCLUSIONS

Use of manure from smaller livestock farms as sole substrate to produce biogas and generate electricity requires special conditions for investment and project financing. Although the main purpose of such plants is environmental protection, they may contribute significantly to sustainability of rural areas by additional income for farmers, proper manure disposal and incorporation of small biogas plant as energy facility in agricultural production. The required price for electricity fed to the grid strongly depends on the source of financing, whereby investing from own sources allows for the half of electricity price comparing to the case of financing from bank loan. Although covering the digestate storage enables collecting the additional methane quantities and therewith additional energy recovery shows worse economic results, this technological option should be supported due to environmental aspects. Although installing the cheaper, but less efficient CHPU, shows better economic results, this technological option is not recommendable due to low reliability of the key facility part that enables energy conversion of biogas. Due to high specific investment costs for such plants, the technical-technological configuration of small biogas plants should be as simple as possible. If investment in auxiliary infrastructure to supply the heat to neighboring residential objects is not subsidized, but financed by biogas plant owner, at least one third of the produced heat should be marketed. Accumulated equities after the project duration could enable a farmer to invest in a new renewable energy project.

## ACKNOWLEDGEMENT

This research was financed by the project of the Department of Environmental Engineering at the Faculty of Technical Sciences–Development of innovative engineering approaches to improve the environment and occupational safety (Razvoj inovativnih inženjerskih pristupa za unapređenje stanja životne i radne sredine).

## REFERENCES

- Bundesministerium für Wirtschaft und Energie (BMWi). (2014). Gesetz für den Ausbau erneuerbarer Energien (Erneuerbare-Energien-Gesetz - EEG 2014). Berlin, Germany.
- Bundesnetzagentur (BNA). (2021a). Marktstammdatenregister: Erweiterte Einheitenübersicht. (<https://www.marktstammdatenregister.de/MaStR/Einheit/Einheiten/ErweiterteOeffentlicheEinheit/enuebersicht>, accessed 09.2021). Bonn, Germany.
- Bundesnetzagentur (BNA). (2021b). Beendete Ausschreibungen. ([https://www.bundesnetzagentur.de/DE/Sachgebiete/ElektrizitaetundGas/UnternehmenInstitutionen/Ausschreibungen/Biomasse/BeendeteAusschreibungen/BeendeteAusschreibungen\\_node.html](https://www.bundesnetzagentur.de/DE/Sachgebiete/ElektrizitaetundGas/UnternehmenInstitutionen/Ausschreibungen/Biomasse/BeendeteAusschreibungen/BeendeteAusschreibungen_node.html), accessed 09.2021). Bonn, Germany.
- Deutsches Biomasseforschungszentrum gemeinnützige GmbH (DBFZ). (2013). Leitfaden Biogas – von der Gewinnung zur Nutzung. Fachagentur Nachwachsende Rohstoffe e.V. (FNR), Gülzow, Germany.
- Edenhofer, O., Pichs-Madruga, R., Sokona, Y., et al. (2014). Climate Change 2014: Mitigation of Climate Change. Contribution of Working Group III to the Fifth Assessment Report of the Intergovernmental Panel on Climate Change. IPCC, Cambridge University Press, Cambridge, UK and New York, NY, USA.
- European Biogas Association (EBA). (2021). EBA Statistical Report 2020. Brussels, Belgium.

- Fachverband Biogas e.V. (FvB). (2021). Branchenzahlen 2019 und Prognose der Branchenentwicklung 2020. ([https://biogas.org/edcom/webfvb.nsf/id/ DE Branchenzahlen](https://biogas.org/edcom/webfvb.nsf/id/DE_Branchenzahlen), accessed 09.2021).
- Lepotic Kovacevic, B., Stojiljkovic, D., Lazarevic, B. (2010). Construction of plants and electricity/heat generation from biomass in the republic of Serbia – Guide for investors. Ministry of Mining and Energy of Republic of Serbia, Belgrade, Serbia.
- Lohani, S.P., Dhungana, B., Horn, H., Khatiwada, D. (2021). Small-scale biogas technology and clean cooking fuel: Assessing the potential and links with SDGs in low-income countries – A case study of Nepal. *Sustain. Energy Technol. Assess.* 46, 101301.
- Martinov, M., Djatkov, Dj., Krstic, J., Ristic, M., Golub, M., Viskovic, M., Sucov, J., Mesaros, Lj. (2012). Biogas postrojenje– uputstvo za izradu prethodnih studija opravdanosti sa primerom za jedno biogas postrojenje (*Biogas plant– instruction for potential investors in economic evaluation of investment with one example* srp.). Faculty of Technical Sciences, Novi Sad, Serbia.
- Ministry of Environmental Protection of Republic of Serbia (MEPRS). (2017). Second Report of the Republic of Serbia under the United Nations Framework Convention on Climate Change. ([http://unfccc.int/sites/default/files/resource/SNC%20Eng\\_Serbia.pdf](http://unfccc.int/sites/default/files/resource/SNC%20Eng_Serbia.pdf), accessed 09.2021). Belgrade, Serbia.
- Ministry of Mining and Energy of Republic of Serbia (MMERS). (2021). Renewable energy law. Official Gazette 40/2021, Belgrade, Serbia.
- Ministry of Mining and Energy of Republic of Serbia (MMERS). (2020). Register of privileged electricity producers, Sector of Biogas plants. <https://mre.gov.rs/sites/default/files/registri/registar.html>, accessed 12.2020). Belgrade, Serbia.
- Ministry of Mining and Energy of Republic of Serbia (MMERS). (2014a). Energy law. Official Gazette 145/2014, Belgrade, Serbia.
- Ministry of Mining and Energy of Republic of Serbia (MMERS). (2014b). Regulation on subsidy measures for electricity generation from renewable resources and high efficient cogeneration. Official Gazette 56/2016. Belgrade, Serbia.
- Roubik, H., Mazancova, J. (2020). Suitability of small-scale biogas systems based on livestock manure for the rural areas of Sumatra. *Environ. Dev.* 33, 100505.
- Scholwin, F., Grope, J., Clinkscales, A., Daniel-Gromke, J., Rensberg, N., Denysenko, V., Stinner, W., Richter, F., Raussen, T., Kern, M., Turk, T., Reinhold, G. (2019). Aktuelle Entwicklung und Perspektiven der Biogasproduktion aus Bioabfall und Gülle. Umweltbundesamt, Dessau-Roßlau, Germany.
- Singh, P., Kalamdhad, A.S. (2022). Assessment of small-scale biogas digesters and its impact on the household cooking sector in India: Environmental-resource-economic analysis. *Energy Sustain Dev* 70, 170-180.
- Statistical Office of the Republic of Serbia (SORS). (2021). Agriculture, forestry and fishery– Livestock breeding. (<https://www.stat.gov.rs/oblasti/poljoprivreda-sumarstvo-i-ribarstvo/stocarstvo/>, accessed 09.2021). Belgrade, Serbia.
- Stinner, W., Stur, M., Paul, N., Riesel, D. (2015). Güllekleinanlagen. Fachagentur Nachwachsende Rohstoffe e.V. (FNR), Gülzow, Germany.
- Viskovic, M., Djatkov, Dj., Nesterovic, A., Martinov, M., Cvetkovic, S. (2022). Stajnjak u Srbiji – količine i emisije gasova s efektom staklene bašte (*Manure in Serbia: Quantities and greenhouse gas emissions* srp.). *J. Agric. Sci. (Belgr.)* 67(1), 29-46.



## POSSIBILITIES FOR FINANCING OF NEW BIOGAS PLANTS IN SERBIA

Miodrag VISKOVIĆ\*, Djordje DJATKOV, Aleksandar NESTEROVIC, Milan MARTINOV

\*E-mail of corresponding author: miodragviskovic@uns.ac.rs

University of Novi Sad, Faculty of Technical Sciences, Chair of Biosystems Engineering,  
Trg Dositeja Obradovica 6, 21000 Novi Sad

### ABSTRACT

*The objective of this paper was to investigate the situation in the previous period, to define the status as well as the prospect of the biogas sector in Serbia. In the period 2010-2022, dozens of biogas plants were built in Serbia thanks to the introduction of an incentive measure – the Feed-in tariff. With the adoption of the new Renewable energy law, a hybrid incentive system was established, which is based on an auction system for market premiums and Feed-in tariffs for plants smaller than 500 kW. The high purchase price of corn silage that reached 50 € t<sup>-1</sup> in 2022, set the high required price for the delivered electricity from biogas. According to the new incentive system, new plants that would use corn silage as a basic substrate would have to have a 24-25 c€ kWh<sup>-1</sup> minimum subsidized electricity price. Incentive measures for biomethane do not exist yet, and the strategic basis for encouraging the production of biofuels based on the goals set is insufficient. The extremely high price on the international market of natural gas and the optimistic goals for biomethane set by the EU could be a driver for the realization of future biomethane plants in Serbia. The guarantees of origin and other types of green certificates could be an additional source of their income. Without clear strategic decisions, there will be no further development of the biogas sector in Serbia. The focus should be on incentives to produce biomethane and use organic waste as one of substrates.*

**Keywords:** Biogas, biomethane, electricity, incentives, subsidies

### INTRODUCTION

In the period from 2010 to 2022, agricultural biogas plants were built at 28 locations in Serbia (few more plants are expected to be completed by the end of 2022, while two facilities have stopped working in the meantime) (MMERS, 2022a). The total installed capacity of all

currently operational agricultural biogas plants is approximately 33 MW (by the end of 2022, 36.5 MW can be expected). This fulfilled the goal of 30 MW by 2020, which was defined by the National renewable energy action plan (MEDEP, 2012). In Serbia, there is currently neither a single existing plant that produces biomethane, nor is it currently being planned.

The construction of the biogas plant was initiated by the first Regulation on incentive measures for the production of electricity using renewable energy sources in 2009 (MMERS, 2009). Then, a financial incentive measure, Feed-in tariff, was defined for the construction of biogas plants in Serbia. The value of the Feed-in tariff has been redefined several times, with the Regulation from 2014 being the most important one (MMERS, 2014a). During the mentioned period, as an incentive measure, the ministry responsible for energy, in cooperation with the Global Environment Facility (GEF) and the United Nations Development Program (UNDP), also allocated certain grants for several biogas plants. There were also certain administrative incentive measures (for example, exemption from customs duties for equipment, exemption from balance responsibility), but it is unknown to what extent the administrative measures influenced the implementation of the biogas projects. Therefore, the key incentive measure was the Feed-in tariff, and this incentive model was replaced by a hybrid model of the new Renewable energy law and accompanying by-laws in 2021-2022 (MMERS, 2021).

In the EU, in addition to Feed-in tariffs, there are/were various other models of incentive measures for biogas plants, such as, feed-in premiums, tradable green certificates, tenders, contracts for difference, *etc.* The incentive measures are/were economic, financial and administrative (Banja *et al.*, 2019), and resulted in the construction of thousands of plants. Combined biogas and biomethane production in Europe in 2020 amounted to 191 TWh or 18 bcm (billion cubic meters) and this figure is expected to double by the end of 2030 (EBA, 2021).

In Serbia, until the end of 2021, dozens of temporary privileged producer statuses have been issued for biogas plant projects with a total installed capacity of about 40 MW. Most of these projects have not been implemented and the circumstances are such that their implementation has mostly been abandoned. The primary causes for the slowdown and even the definitive cancelation of these projects are the COVID 19 pandemic, the war in Ukraine and the drought in 2022. These three factors indirectly affected the prices of substrates and other consumables, the purchase price and availability of equipment. Within the current market conditions, the necessary high subsidized price of electricity or the possibility of realizing other ways of generating income for biogas plants have a huge impact on the further development of this sector in Serbia.

The objective of this paper was to investigate and analyze the possibilities of financing future biogas plants in Serbia. Focus is applicability of the new incentive system for electricity production defined by the newly adopted Renewable energy law. Other types of financial incentive measures that can contribute to the further development of the biogas sector in Serbia were also analyzed.

## MATERIALS AND METHODS

The focus of the paper was on the Renewable energy law (MMERS, 2021) and adopted by-law documents by the end of 2022. Additionally, the currently valid by-laws adopted based



on the previous (still valid in some fields) Energy law (MMERS, 2014a) was also analyzed. Reason for this is because most of the new by-laws have not yet been adopted.

The method of the research involves a detailed analysis of the newly established incentive system, an experiential assessment of their applicability through comparison with the earlier system. The financial assessment of the applicability of new methods of incentives assumes that the realized production cost of electricity should be up to 50% of the income made from the electricity sale. This assumption is consistent with the methodology in Djatkov *et al.* (2021).

For this paper, it was analyzed past and current market purchase cost of corn silage in order to determine how it influenced the development of the biogas sector and what are the current impacts.

The cost of generated energy (in form of methane) and cost of corn silage of the generated electricity were calculated by equations 1 and 2, respectively. It was assumed that  $200 \text{ Nm}^3 \text{ t}^{-1}$  of biogas is obtained from corn silage with a methane content of 52% (FNR, 2010). The lower calorific value of methane was  $9.97 \text{ kWh Nm}^{-3}$ . It was assumed that the efficiency of the cogeneration unit is 41%,

In the case of production and selling of biomethane, and other possibilities for financial gains, description of prerequisites and current applicability of these systems are provided in the result section. For calculation of the cost of produced biomethane, equation 3, it was used unofficial information of the German biogas association that the cost of refining and injecting biomethane into the grid is app.  $20 \text{ € MWh}^{-1}$  ( $2 \text{ c€ kWh}^{-1}$ ).

$$\text{Cost of generated energy [€ MWh}^{-1}\text{]} = \frac{\text{Corn silage purchase price}}{\text{methane yield} * \text{lower calorific value}} * 1000$$

$$\text{Cost of corn silage in gen. el. [c€ kWh}^{-1}\text{]} = \frac{\text{Cost of generated energy}}{\text{efficiency of cogeneration unit} * 10}$$

$$\text{Cost of produced biomethane [€ MWh}^{-1}\text{]} = \text{Cost of gen. en.} + \text{cost of ref. and injecting}$$

## RESULTS AND DISCUSSION

### *Corn silage purchase price*

The most important substrate for biogas production in Serbia is corn silage. For this substrate there is a limitation in terms of use (MMERS, 2014b), but plant managers tend to maximize its use in terms of quantity, wherewith the dominant amount of biogas is produced from this substrate. Other substrates are all types of manure, by-products from sugar mills and other food plants, waste oils and small amounts of harvest residues. Due to dominance of corn silage, it was considered for this paper that future biogas plants would also use this substrate as a basic one.

Formation of the market price of corn silage is directly related to the price of corn grain. In the first years of intensive production of corn silage for the biogas plants, the opinion was formed that the price of corn silage is (approximately) 20% of the price of corn grain. The production price of silage is then about 60% of the market price. A good explanation of this

principle is provided by Martinov and Djatkov (2012). In the period from 2013 to the end of 2020, the price of corn grain varies in the range of 15 to 20 RSD kg<sup>-1</sup> (without VAT) (NSCOMEX, 2022). The purchase price of corn silage was relatively stable in that period and was between 3 and 4.4 RSD kg<sup>-1</sup> (approximately between 28 and 35 € t<sup>-1</sup>). The most represented price of corn silage on the market, until the end of 2020, was 35 € t<sup>-1</sup>. The stability of that price is one of the positive factors that led to the realization of the existing biogas plants. During 2021, there is an intense increase in the prices of raw materials, primarily mineral fertilizers such as urea, and the price of corn grain rise, so that in April 2021 it has exceeded the price of 24 RSD kg<sup>-1</sup> (NSCOMEX, 2022). From February 24, 2022, there is a sudden jump in the price of corn grain, and ending with August 2022, the price of corn stabilizes to about 34 RSD kg<sup>-1</sup>. The sudden increase in the price of corn grain had a negative impact on the market price of silage, the real price of which is currently even higher than 6 RSD kg<sup>-1</sup> (50 € t<sup>-1</sup>), but the contracted price for corn silage harvested in 2022 was usually 50 € t<sup>-1</sup>. The importance of the price of corn silage is reflected in the fact that it is the basis for forming the price of other energy plants and waste substrates (except manure).

#### ***The cost of generated energy and the cost of corn silage of the generated electricity***

Half of the implemented agricultural biogas plants in Serbia have an installed power of 999 kW and in 2022 they achieve the Feed-in tariff of 19.03 c€ kWh<sup>-1</sup>. In 2017, the Feed-in tariff was 17.23 c€ kWh<sup>-1</sup>, so in the last five years the Feed-in tariff has increased by 1.8 c€ kWh<sup>-1</sup> due to inflation.

If the corn silage price is 50 € t<sup>-1</sup>, it means that Nm<sup>3</sup> of methane in Serbia from this substrate is currently 0.48 €, or that energy contained in that methane is 48 € MWh<sup>-1</sup>. The cost of the corn silage of generated electricity is approximately 11.76 c€ kWh<sup>-1</sup>. For a corn silage price of 35 € t<sup>-1</sup> as it was in 2017, this cost was 8.23 c€ kWh<sup>-1</sup>.

By comparing the price of the Feed-in tariff and the cost of the corn silage of generated electricity in 2017, the cost of the substrate is approximately 50% of the realized Feed-in tariff. In 2022, this ratio amounted to almost 62% and this increase is the reason why biogas plants in Serbia currently have significant financial difficulties and operate on the verge of profitability.

#### ***Hybrid incentive system for electricity based on the Renewable energy law***

The Renewable energy law provides the opportunity for future biogas plants larger than 500 kW to be guided by market principles for determining the maximum achievable price of generated electricity. The system is designed so that future projects are auctioned at the price of the market premium, which would be added to the market price of electricity.

Certainly, the future decision on the quotas (adopted by the Government of Republic of Serbia - GRS) and the maximum purchase price/premium of electricity will have an extremely large impact on the defined system. The maximum purchase price of electricity will be calculated by the method in the official decision (AERS, 2021a), and will be published by the Energy agency of the Republic of Serbia. At the end of 2021, the Government announced a quota for the use of wind power plants larger than 3 MW (GRS, 2021c). The quota is 400 MW. The maximum purchase price was determined by the Energy agency, and it is 5.568 c€ kWh<sup>-1</sup> (the electricity price, not the market premium which is confusing and probably poorly explained) (AERS, 2021b). Previously built wind power plants in Serbia had the Feed-in tariff of 9.2 c€ kWh<sup>-1</sup> (MMERS, 2014b). The auction was supposed to be organized at the

beginning of 2022, but it was not carried out. Unofficial information is that the extremely low maximum purchase price does not favor the construction of new power plants. A frustrating circumstance for other types of renewable energy sources is that this auction was supposed to serve as an example of the procedure of the auction system: 1. Qualification, 2. Auctioning and 3. Making decisions. As of November 2022, there is no official information on new quotas for other renewables, and it is likely that the year 2022 will end without a successful launch of the auction system.

Facilities below 500 kW and demonstration projects are subject to the Feed-in tariff system, but the system itself is bureaucratically not too different from the auction system with market premiums. A single value of the Feed-in tariff is not foreseen (as was defined by the old regulations valid until the end of 2021), but potential plants also participate in the auction. In this way, it is guaranteed that the facility that has a Feed-in tariff always has a fixed purchase price determined through the auction system (there is no variable part that depends on electricity market price). By the end of November 2022, no quota for small plants (of any kind) has been established.

Assuming that the substrate cost of generated electricity in the biogas plant is currently (in 2022, based on the cost of corn silage)  $11.76 \text{ c€ kWh}^{-1}$ , and assuming that the maximum share of the substrate cost in the realized income from the sale of electricity is 50%, it follows that the minimum price necessary for the purchase of electricity is currently approximately  $24 \text{ c€ kWh}^{-1}$ . This is a higher price than the currently valid Feed-in tariff, which is achieved by biogas plants with a capacity of 999 kW in Serbia. For plants smaller than 500 kW, the realistic Feed-in tariff would also have to be around  $24\text{--}25 \text{ c€ kWh}^{-1}$ .

Considering the official reasons for abolishing the old system of Feed-in tariffs (for example, lower expenditures on state aid, lower costs for citizens, greater reliance of producers on market mechanisms, *etc.*), and also by taking in consideration the example of the maximum defined purchase price for the electricity made from wind, it is almost impossible to expect that the maximum purchase price for electricity will be high enough to make classic agricultural biogas plants, larger or smaller, financially interesting projects.

Biogas plants in Serbia that would generate and sell electricity under the current hybrid incentive system would have to focus on utilization of cheaper substrates. It is necessary to plan the consumption of substrates that would enable a minimum cost within the production cost per kWh of generated electricity. Only manure, organic waste from the food industry and harvest residues have a lower energy cost compared to corn silage and other types of energy plants. The problem with manure and organic waste is an availability and procurement. Waste from food industry is not generated in quantities sufficient to satisfy the new plants, most of the capacity is already used, and the price is subject to the existing corn silage market, which unrealistically raises their price as demand grows. Manure from large farms in Serbia is used in significant quantities. There is capacity for new plants, but the problem with manure is reflected in the uncertain future of the livestock sector itself, whose livestock number is constantly decreasing (Viskovic *et al.*, 2022). Manure from smaller farms could be additionally used by the implementation of small biogas plants, which for financially profitable operation should have a Feed-in tariff of at least  $24 \text{ c€ kWh}^{-1}$  (Djatkov *et al.*, 2021). The solution could be the intensive use of crop residues as a substrate for biogas production. However, this requires more advanced treatment technologies or anaerobic digestion itself. Although such technologies require significantly higher capital expenditures, the relatively low price of crop residues (in 2022 the maximum price of straw was up to  $55 \text{ € t}^{-1}$ ) makes

them financially more profitable and lowers the minimum electricity purchase price up to app. 20 c€ kWh<sup>-1</sup>.

### *Incentives for biomethane*

The field of biofuels is currently in the phase of dual legal regulation by the Energy law and the Renewable energy law. It is important to state that the new decree on conditions of delivery and supply of natural gas (GRS, 2022b) recognizes biogas (not biomethane which is mistake) as a fuel suitable for natural gas grid. This is important step toward both technical and legal prerequisites for any future biogas plant that decide to inject biomethane into the natural gas grid.

The Energy law theoretically defined incentive measures for biomethane in the form of a guaranteed share of biofuels on the market of the Republic of Serbia. Energy entities that produce and trade fossil fuels are obliged to place a certain amount of biofuel on the market (MMERS, 2014a). The decision from 2022 states that by the end of 2025, that share should be 1% (percentage of energy contained in biofuel in total fuel energy) (GRS, 2022a). Methane originating from anaerobic digestion is recognized in the regulation under the name biogas (it is stated that lower calorific value is 50 MJ kg<sup>-1</sup>). Organic waste substrates, harvest residues and manure are raw materials to produce biofuels whose energy value should be counted twice (MMERS, 2014a). Biogas (the regulation uses the wrong term) needs to meet sustainability criteria to be considered eligible to count as a biofuel. The most important criterion is certainly the GHG emissions saving (GRS, 2019). Energy entities should theoretically pay penalties if they do not provide the appropriate share of biofuel (MMERS, 2014a), and the mechanism is designed so that it is more profitable for them to directly finance the plant to produce certified biofuel instead of penalties. In this way, energy entities directly provide financial support to biofuel production plants. The area of biofuels regulated based on the Energy law is obviously obsolete in terms of the current EU trends concerning biomethane. For example, the sustainability criteria are in accordance with the RED I directive, not the RED II directive, which was already effective at the time of the adoption of the regulations.

The impression is that apart from the current targets for the share of biofuels, the entire area of biomethane production should, although there is no official obligation for this, be seen as a part of the Renewable energy law. This law clearly classifies biomethane in the group of biofuels for transport (the definition is appropriate) and introduces the term Investment State Aid as an incentive measure. This measure will be applicable for advanced biofuels, and it is assumed that biomethane obtained from waste raw materials or crop residues could have that status. Unfortunately, the by-laws that should assemble this area have not yet been adopted.

Regarding the use of biofuels, it is certainly an aggravating circumstance that the Integrated National Energy and Climate Plan for the period 2021 to 2030 with a vision to 2050 has not yet been adopted. It is expected that this plan be finally adopted in 2023 (MMERS, 2022b).

Mechanisms of the Investment State Aid should be more clearly explained in the Integrated National Plan, and only then it will be seen whether biomethane projects can expect more concrete financial support.

There is not a single plant in Serbia that purifies biogas to the quality of biomethane. The obvious reason for this was the high production cost of biomethane compared to natural gas. It is estimated that during the intensive construction of biogas plants until 2021 in Serbia, the

MWh of biomethane injected into the network costed around 50 € MWh<sup>-1</sup>. With the purchase price of natural gas of approximately 20-25 € MWh<sup>-1</sup>, biomethane could not be competitive without direct subsidies, which were absent. Due to the increase of corn silage prices, it can be estimated that the current cost of biomethane in Serbia would be around 70-80 € MWh<sup>-1</sup>. By using crop residues, for example, the price could be relatively lower, but it is important fact that the costs of purification and injection depend on the size of the plant. Also, a technically sustainable plant to produce biomethane would have to use a minimum of 9-10 thousand tons of crop residues annually which is a significant logistical challenge.

However, due to the energy instability caused by the crisis in Ukraine, there is an obvious upward trend in the price of natural gas, which during 2022 reached a price of up to 340 € MWh<sup>-1</sup> (TE, 2022). Due to the new energy reality, EU, through its latest decisions and strategies, sets extremely optimistic goals regarding the production of biomethane (Fit for 55 package; REPowerEU; ReFuelEU), which amounts to 35 bcm by 2030. The binding targets have not been officially adopted, but it is obvious that the EU is counting on the biogas sector, or more precisely on biomethane production and not electricity from biogas.

The EU's ambitious goals for biomethane can also initiate the construction of the first biogas plants that produce biomethane in Serbia. The question of infrastructure is raised, *i.e.*, clearly regulated technical aspects of connection, and perhaps financial incentives through the mentioned mechanism of Investment State Aid in infrastructure. Such types of state aid exist in EU countries (Banja *et al.*, 2019). Statistically speaking, the construction of biogas plants that use biogas to generate electricity is approaching stagnation, while there is noticeable growth in plants that produce biomethane (EBA, 2021).

### ***Other types of financial support***

According to the Renewable energy law (this was also the case with the Energy law) there is a possibility of building a power plant and obtaining a status of Producer of electricity from renewable energy sources (MMERS, 2014a; MMERS 2021; GRS, 2019). Such plants do not have the right to incentives through the auction system or through the Feed-in tariff, but they have the right to the Guarantees of Origin (GOO). Issuing GOO in Serbia is the responsibility of the electricity distribution system operator ("Elektromreža Srbije"), which is a member of the Association of Issuing Bodies (AIB) (EMS, 2019). The GOO is financial support measure for many power plants in Serbia but not a single biogas plant realizes financial gain in this way (EMS, 2022). Theoretically, GOO for biogas plants could be interesting way of obtaining additional income if their status of the privileged electricity producer ends or if maybe some biogas plant decides to abandon the privileged status before guaranteed period of twelve years ends. The whole procedure, and possible prices of GOO for biogas plants in Serbia is still unknown and hard to predict. Official data shows that in the region for example, in Croatia, several biogas plants have been part of GOO system (EMS, 2022).

Production of biomethane is part of EU ETS system for trading of green certificates. In this system, it is also GOO used as a tool for tracing produced and used biomethane. In Serbia, EU ETS system is still undeveloped, and it is unclear how this mechanism will be implemented in the sector of biogas since the Law on climate change (MEP, 2021) is adopted last year and by-laws are still missing. Even more important is the fact that certification bodies still don't have enough experience and enough trained personnel to clearly say how this trading system will be, or if even it will be implanted in Serbia in the sector of biogas/biomethane.

## CONCLUSIONS

The global crisis, which has been lasting since March 2019, has shown that the biogas sector in Serbia is extremely sensitive to drastic fluctuations in the prices of substrates, consumables, and services. Given that practically the only source of income can be achieved through the electricity sale, lots of biogas plants have come to a situation where they operate at the limit of profitability during 2022. This situation and completely new system for incentive measures in Serbia have put biogas sector in an extremely bad position and if the bad governmental decisions regarding electricity purchase price, organization of Investment State Aid for biomethane, or certification of electricity from biogas/biomethane would adopted, the biogas sector will stop to further develop. To avoid this, governmental bodies should be aware of possible problems and sensitivity of this sector. Biogas plants should never be considered only as energy providers, but also as an important player in the waste management value chain, which should be also the driving force for future smart decision making regarding the biogas sector in Serbia.

## ACKNOWLEDGEMENT

This research was financed by the project of the Department of Environmental Engineering at the Faculty of Technical Sciences– Development of innovative engineering approaches to improve the environment and occupational safety (*Razvoj inovativnih inženjerskih pristupa za unapređenje stanja životne i radne sredine*).

## REFERENCES

- Banja, M., Jégard, M., Motola, V., Sikkema, R. (2019). Support for biogas in the EU electricity sector – A comparative analysis. *Biomass bioenergy* 128, 105313.
- Djatkov, Dj., Viskovic, M., Martinov, M., Nesterovic, A., Bojic, S., Effenberger, M., Venus, T. (2021). Small biogas plants. Faculty of technical sciences. Novi Sad, Serbia.
- Energy agency of the Republic of Serbia (AERS). (2021a). Decision of Council of Energy agency of the Republic of Serbia on adoption of the Methodology for determining the maximum purchase price of electricity. *Official Gazette* 103/2021.
- Energy agency of the Republic of Serbia (AERS). (2021b). Decision. <https://www.aers.rs/FILES/OIE/2021-12-01%20Odluka%20i%20Obrazlozenje%20Vetroelektrane%202022.pdf>. Belgrade, Serbia.
- European Biogas Association (EBA). (2021). Activity report 2021. <https://www.europeanbiogas.eu/wp-content/uploads/2022/01/EBA-Activity-Report-2021.pdf>
- Fachagentur Nachwachsende Rohstoffe e. V. (FNR). (2010). Guide to Biogas. From Production to use. Guezlow, Germany
- Government of Republic of Serbia (GRS). (2022a). Decision on determining the mandatory share of biofuels that system obligees are obliged to put into circulation on the market of the Republic of Serbia. *Official Gazette* 67/2022. Belgrade, Serbia.
- Government of Republic of Serbia (GRS). (2022b). Decree on conditions of delivery and supply of natural gas. *Official Gazette* 49/2022. Belgrade, Serbia.
- Government of Republic of Serbia (GRS). (2021a). Decree on market premium agreement model. *Official Gazette* 112/2021. Belgrade, Serbia.

- Government of Republic of Serbia (GRS). (2021b). Decree on the quota in the market premium system for wind farms. Official Gazette 107/2021. Belgrade, Serbia.
- Government of Republic of Serbia (GRS). (2019). Decree on sustainability criteria for biofuels. Official Gazette 89/2019. Belgrade, Serbia.
- Government of Republic of Serbia (GRS). (2017). Decree on guarantee of origin. Official Gazette 82/2017. Belgrade, Serbia.
- Joint stock company „Elektromreža Srbije“ Belgrade (EMS). (2019). Rules on issuing guarantees of origin. Belgrade, Serbia.
- Joint stock company „Elektromreža Srbije“ Belgrade (EMS). (2022). Register of guaranties of origin. <https://cmo.grexel.com/Lists/PublicPages/Statistics.aspx>. (Accessed October 2022).
- Martinov, M., Djatkov, Dj., et.al. (2012). Biogas plant – guidelines for feasibility studies including an example for one biogas plant. Faculty of Technical Sciences. Novi Sad, Serbia.
- Ministry of Energy, Development and Environmental Protection (MEDEP). 2012. National renewable energy action plan of the Republic of Serbia. Belgrade, Serbia.
- Ministry of Environmental protection (MEP). (2021). Law on climate changes. Official Gazette 26/2021. Belgrade, Serbia.
- Ministry of Mining and Energy of Republic of Serbia (MMERS). (2022a). Register of privileged electricity producers, Sector of Biogas plants. <https://mre.gov.rs/sites/default/files/registri/registar.html>, accessed 09.2022). Belgrade, Serbia.
- Ministry of Mining and Energy of Republic of Serbia (MMERS). (2022b). Regulation on the content and guidelines for determining the national goals of the Integrated National Energy and Climate Plan, the method of its preparation and reporting on its implementation. Official Gazette 49/2022. Belgrade, Serbia.
- Ministry of Mining and Energy of Republic of Serbia (MMERS). (2021). Renewable energy law. Official Gazette 40/2021, Belgrade, Serbia.
- Ministry of Mining and Energy of Republic of Serbia (MMERS). (2014a). Energy law. Official Gazette 145/2014 and 95/2018. Belgrade, Serbia.
- Ministry of Mining and Energy of Republic of Serbia (MMERS). (2014b). Regulation on subsidy measures for electricity generation from renewable resources and high efficient cogeneration. Official Gazette 56/2016. Belgrade, Serbia.
- Ministry of Mining and Energy of Republic of Serbia (MMERS). (2009). Regulation on subsidy measures for electricity generation from renewable resources and combined production of electricity and heat energy. Official Gazette 99/20092. Belgrade, Serbia.
- Produktna berza Novi Sad (NSCOMEX). (2022). <https://nscomex.com/en/products/corn/>. Novi Sad, Serbia. (Accessed November 2022).
- Trading economics (TE). (2022). <https://tradingeconomics.com/commodity/eu-natural-gas>. (Accessed October 2022).
- Viskovic, M., Djatkov, Dj., Nesterovic A., Martinov, M., Cvetkovic, S. (2022). Manure in Serbia: Quantities and greenhouse gas emissions. J. Agric. Sci. 67(1), 29-46.

---

---





## CAUSES AND CONSEQUENCES OF WORK EVENTS IN THE FOOD INDUSTRY ENTERPRISES FROM TIMIS COUNTY

Rudolf MIRESCU<sup>1</sup>, Alexandru TUCU<sup>2</sup>, George Catalin CRISAN<sup>3</sup>, Emil KAZOMIR<sup>1</sup>,  
Dumitru TUCU<sup>1\*</sup>

\*E-mail of corresponding author: dumitru.tucu@upt.ro

<sup>1</sup>Mechanical Machines and Transportation, Politehnica University Timisoara,  
No.1, Mihai Viteazu Av., RO-300011 Timisoara, Romania

<sup>2</sup>Faculty of Entrepreneurship, Business Engineering and Management, Politehnica University,  
No.313, Spl. Independentei, Sect.6, Bucuresti, RO-060042

<sup>3</sup>S.C. PROMUN S.R.L., Arad, Romania

### ABSTRACT

*The paper has the main objective to identify and hierarchize the significant factors and causes of work events in the food enterprises, from Timiș County as integrated part in the process of assessment and general optimization of specific occupational health and safety risk management systems (OHSRMS). Based on specific activity (CAEN code), the work events from last 10 years were selected, correlated with the field of activities of enterprises, number of employees and factors and causes (if necessary, also other special conditions). After collecting data from official statistics, consequences of accidents, number of employees and elements for enterprises localisation, 819 active enterprises were selected in the food industry field. According to the group of special field of activities (ex.: meat processing and preservation, processing and preserving poultry meat, manufacturing of meat products (including poultry), manufacture and processing of fruit and vegetable juices etc.), 25 groups were selected. Using statistical methods and reports of work events/employee, the groups were evaluated according to the work accidents. The relevance was verified by Fisher test. Also, using ANOVA, possible relations between field of activities and work events were identified. All results indicated strong disparities between OHSRMS and the possibility to reduce the accident rate at work by efficient measures and limitation of the access of workers in danger areas. Conclusions and results of present work can be generally used in practical optimization of the OHSRMS in enterprises from food industry.*

**Keywords:** occupational health and safety risk management system, food processing, work accident/event, optimization

## INTRODUCTION

Food industry workers' health and hygiene are common interest for workers, owner and public authorities, due the effect and social consequences (Clayton M et al., 2016). Improving occupational health and safety risk management system in food industry system jobs is important also because the perception of risk factors, almost consequences, still remaining at low level (Tucu et al., 2019; Crisan et al., 2017; Bodescu et al., 2022; Tucu et al., 2021a). Despite the efforts made, the occurrence of work accidents continues to show that OHS performance evaluation remains subject to interpretation (Jemai et al., 2021). Different models were developed for evaluation of the most important risk factors: the stress at work determined by different causes (Gusetoiu and Tucu, 2012; Gusetoiu and Tucu, 2013), preliminary model for evaluating risk management maturity in small and medium-sized (Kaassis and Badri, 2018), non-adherence to safe operating procedures (unsafe acts) by employees (Tatenda and Pedzisai, 2022), etc.

The hazardous activity from food industry and high rate of injuries (Jadhav et al., 2015; Jadhav et al., 2016), needs preventive activities in conditions of enterprises safety actions and performing of their systematic review.

Based on author's previous experience in the frame of legal authority requirements, the paper has the main objective to account and hierarchize the significant work events in the food processing enterprises, in Timiș County, the factors and their causes. The actions were considered integrated parts in the process of assessment and general optimization of specific occupational health and safety risk management systems (OHSRMS).

## METHODS

Starting at specific activity of enterprises (CAEN code, 2022), the work events from last 10 years (2012-2021) were selected, correlated (grouped) on their field of activities, number of employees and factors and causes (if necessary, also other special conditions). After collecting data from official statistics, consequences of accidents, number of employees and elements for enterprises localisation, 819 enterprises from the food industry field were selected. According to the group of special field of activities (ex.: 1011 - meat processing and preservation, 1012 - processing and preserving poultry meat, 1013 - manufacturing of meat products (including poultry), 1071 - bread making; manufacturing of cakes and fresh pastry products etc.), 25 groups were selected. Using statistical methods and reports of work events/employee, the groups were evaluated according to the work and healthy risks.

For statistic analyse only enterprises with accidents were considered. The relevance was verified by Fisher test. Also, using ANOVA, possible relations between field of activities and work events were identified. All statistical analysis used Microsoft Excel and STATEGRAPHICS Centurion XVI. Conclusions and results of present work were prepared to be generally used in practical optimization of the OHSRMS in enterprises from food industry for improve the conformity with EU and state strategy (ESENER, 2022).

## RESULTS AND DISCUSSION

Table 1 presents all information collected from enterprises involved in food industry, all 25 group of activities (only enterprises where was minimum an accident on year).

**Table 1** Recorded accident in food industry, Timiș County

Year	Code	Enterprise	Deads			Invalidity			Temporary Inability at work				N	NE
			E	Ad	AR	E	Ad	AR	E	Ad	AR	D		
2012	1011	SMITHFIELD PROD SRL	0	0	0	0	0	0	3	0	0	77	3	1060
2012	1011	CARNEXIM BANAT SRL	0	0	0	0	0	0	1	0	0	9	1	101
2012		TOTAL c							4			86	4	1161
2012	1061	AGROPAN SRL	0	0	0	0	0	0	1	0	0	41	1	15
2012	1071	PREMIUM PARTS SRL	0	0	0	0	0	0	1	0	0	24	1	22
		TOTAL y							6			151	6	1198
2013	1011	SMITHFIELD PROD SRL	0	0	0	0	0	0	3	0	0	112	3	1070
2013	1071	UNIVERSAL COM BOR SRL	0	0	0	0	0	0	1	0	0	11	1	26
		TOTAL y							4			123	4	1096
2014	1011	SMITHFIELD PROD SRL	0	0	0	0	0	0	6	0	2	242	8	1067
2014	1013	TOMADI SRL	0	0	0	0	0	0	1	0	0	48	1	101
2014	1051	SIMULTAN SRL	0	0	0	0	0	0	1	0	0	82	1	217
2014	1052	ANTARTICA SA	0	0	0	0	0	0	1	0	0	20	1	40
		TOTAL y							9	2	392	11	1425	
2015	1011	SMITHFIELD PROD SRL	0	0	0	0	0	0	3	0	0	55	3	1108
		TOTAL y							3	0	0	55	3	1108
2016	1011	SMITHFIELD PROD SRL	0	0	0	0	0	0	3	0	0	86	3	1141
2016	1071	FORNETTI ROMÂNIA SRL	0	0	0	0	0	0	1	0	0	45	1	387
2016	1072	BISCOTTO SRL	0	0	0	0	0	0	1	0	0	32	1	41
		TOTAL y							5			163	5	1569
2017	1011	SMITHFIELD RPROD SRL	0	0	0	0	0	0	5	2	0	575	7	1168
2017	1011	OVI PRODEX	0	0	0	0	0	0	1	0	0	5	1	78
		TOTAL y							6	2	0	580	8	1246
2018	1011	SMITHFIELD PROD SRL	0	1	0	0	0	0	1	0	0	44	2	1168
		TOTAL y		1					1			44	2	1168

Table 1 Cont.

Year	Code	Enterprise	Dead			Invalidity			Temporary Inability at work				N	EN
			E	Ad	AR	E	Ad	AR	E	Ad	AR	D		
2019	1011	SMITHFIELD ROMANIA SRL	0	0	0	0	0	0	6	1	0	301	7	2336
2019	1071	BRUTĂRIA AMRA SRL	0	0	0	0	0	0	1	0	0	14	1	41
2019	1071	FORNETTI ROMÂNIA SRL	0	0	0	0	0	0	1	0	0	10	1	389
2019	1071	E.L.M. SRL	0	0	0	0	0	0	0	0	1	9	1	50
2019	1071	BEGA PAM SA	0	0	0	0	0	0	0	0	1	49	1	59
		TOTAL c							2		2	82	4	539
		TOTAL y							8	1	2	383	11	2875
2020	1011	SMITHFIELD ROMANIA SRL	0	0	0	0	0	0	5	2	0	366	7	2399
2020	1071	FORNETTI ROMÂNIA SRL	0	0	0	0	0	0	0	0	2	65	2	443
2020	1071	FROPIN SA	0	0	0	0	0	0	1	0	0	3	1	72
		TOTAL c							1		2	68	3	515
		TOTAL y							6	2	2	434	10	2914
2021	1011	SMITHFIELD ROMANIA SRL	0	0	0	0	0	1	1	0	2	109	4	2569
		TOTAL y						1	1		2	109	4	2596
		TOTAL P		1				1	49	5	8	2434	64	17195

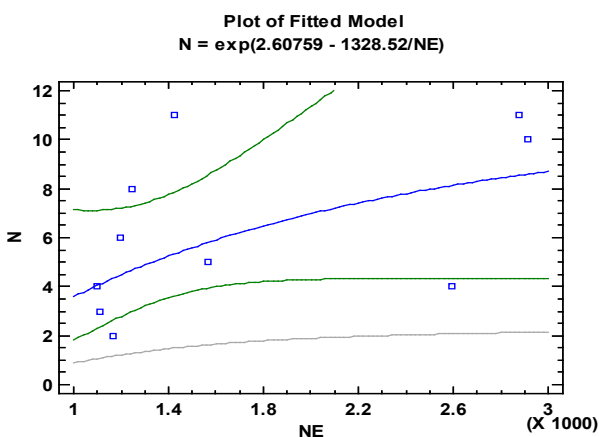
Note: In table 1, the significance of abbreviations are: E – accidents caused by the employee; Ad - accidents caused by administration or responsible work safety; AR – accident on road from/to workplace; D – days of temporary inability; N – number of accidents cumulated on enterprise/year; NE – employee’s number; TOTAL c – total on activity’s code; TOTAL y – total on year; TOTAL P – total for all considered activities and years (panel).

After processing of data using Microsoft Excel few conclusions could be formulated. In the analyzed period only in the next groups of activity were work accidents: 1011, 1013, 1051, 1052, 1061, 1071, 1072. (Complete name of activities could be seen at (CAEN, 2022). Because the average of accident on 1000 workers/year for entire period were the biggest for activities 1011 (4,9 accidents/1000 workers on year) and 1071 (0,83 accidents/1000 workers on year), for each of this group were analyzed the relationship between number of employees and number of accidents and days of temporary inability at work. The results were calculated at 1000 employees according to actual used solutions (Mitchell and Lystad, 2019). The first analysis studied the possible relationship between number of accidents (col\_2) and number of employees (col\_1), starting at simple regression supposing the S-curve model ( $Y = \exp(a + b/X)$ ) (This model was the most adequate after other linear and nonlinear models were tested).

Here Y is total yearly number of accidents (column N at rows TOTAL y in table 1, only for code 1011), and X is the total number of employees (NE, in same conditions). The results of STATGRAPHICS indicated the optimum equation of the fitted model:

$$N = \exp(2.60759 - 1328.52/NE).$$

In Figure 1 can be seen the position in graphic and in Table 2 the results for coefficients and analysis of variance. The statistic parameters (Correlation Coefficient = -0.528724; R-squared = 27.9549 %; R-squared (adjusted for d.f.) = 18.9492 %; Standard Error of Est. = 0.525637; Mean absolute error = 0.391417; Durbin-Watson statistic = 1.6101 (P=0.1379) and Lag 1 residual autocorrelation = 0.189778), indicate a moderately strong relationship between the variables.



**Figure 1** STATEGRAPHICS plot of the fitted model for relation  $N=f(NE)$ , group 1011

Table 2 presents the results for coefficients and analysis of variance in the same regression.

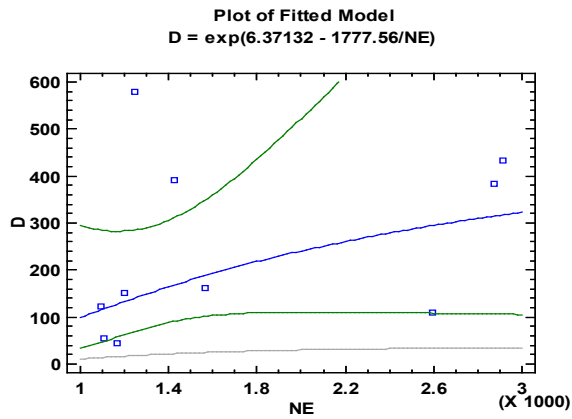
**Table 2** The coefficients and analysis of variance for relation  $N=f(NE)$  for group 1011

Coefficients					
Parameter	Least Squares Estimate	Standard Error	T Statistic	P-Value	
Intercept	2.60759	0.533549	4.88726	0.0012	
Slope	-1328.52	754.044	-1.76186	0.1161	
Analysis of Variance					
Source	Sum of Squares	Df	Mean Square	F-Ratio	P-Value
Model	0.857658	1	0.857658	3.10	0.1161
Residual	2.210350	8	0.276294		
Total (Corr.)	3.068010	9			

As first conclusion, since the P-value in the ANOVA table is greater or equal to 0.05, there is not a statistically significant relationship between number of accidents and number of employees at the 95.0% or higher confidence level. A possible explanation is the differences between the perception level of health & safety risks and the differences between enterprises' OHSRMS regarding functional process and key performance indicators.

Another analysis studied the relationship between number of days of temporary inability at work (D) and number of employees (NE), also by simple regression for the S-curve model ( $Y = \exp(a + b/X)$ ), in the same conditions and motivation. This time Y is total yearly days of temporary inability at work (column D at rows TOTAL y in table 1, only for code 1011), and X is the total number of employees (NE). The results of STATGRAPHICS indicated the optimum equation of the fitted model:

$$D = \exp(6.37132 - 1777.56/NE)$$



**Figure 2** STATEGRAPHICS plot of the fitted model for relation  $D=f(EN)$ , group 1011

**Table 3** The coefficients and analysis of variance for relation  $D=f(EN)$ , for group 1011

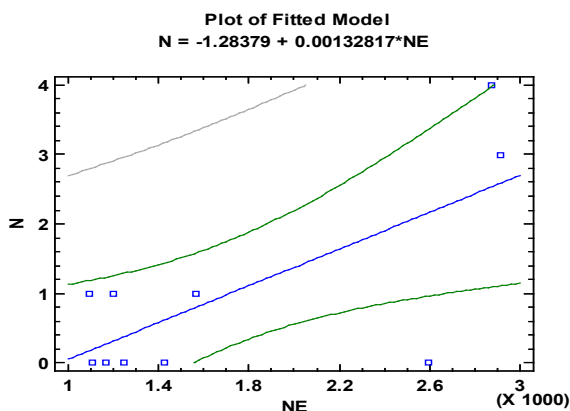
Coefficients					
Parameter	Least Squares Estimate	Standard Error	T Statistic	P-Value	
Intercept	6.37132	0.849931	7.49628	0.0001	
Slope	-1777.56	1201.17	-1.47985	0.1772	
Analysis of Variance					
Source	Sum of Squares	Df	Mean Square	F-Ratio	P-Value
Model	1.53541	1	1.53541	2.19	0.1772
Residual	5.60892	8	0.70111		
Total (Corr.)	7.14433	9			

Figure 2 presents the position in graphic of the model and Table 3 the results for coefficients and analysis of variance. The statistic parameters (R-squared = 21.4914 percent; R-squared (adjusted for d.f.) = 11.6778 percent; Standard Error of Estimations = 0.837326; Mean absolute error = 0.592968; Durbin-Watson statistic = 1.30543 (P=0.0498); Lag 1 residual autocorrelation = 0.338272), indicate the model as fitted explains 21.4914% of the variability in column D (Table 1, only rows TOTAL y), also indicating a relatively weak relationship between the variables. The P-value is less than 0.05 indicating of possible serial correlation at the 95.0% confidence level.

The statistical results confirmed the effect of measures and actions in conditions of wide variety of occupational health and safety hazards and risk of occupational injury or disease through physical or psychological hazards, biological, chemical or disease exposures.

For the group of activities 1071, the next analysis studied the relationship between number of accidents (N) and number of employees (NE), starting at simple regression supposing the linear model ( $Y = a + b \cdot X$ ) (This time were not enough information for another model). For Y was the same significance as number of accidents (column N at rows TOTAL y in table 1, only for code 1071), and X is the total number of employees (NE, in same conditions). The results of STATGRAPHICS indicated the optimum equation of the fitted model:

$$N = -1.28379 + 0.00132817 \cdot NE.$$



**Figure 3** Plot of the fitted model for relation  $N=f(NE)$ , group 1071

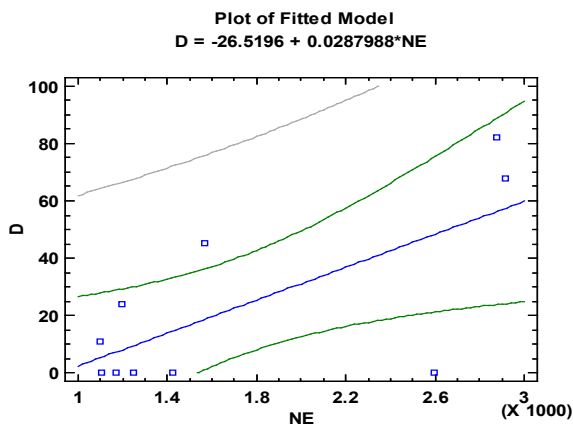
In Figure 3 can be seen the position in graphic and in Table 4 the results for coefficients and analysis of variance. The statistic parameters (Correlation Coefficient = 0.714052; R-squared = 50.987 %; R-squared (adjusted for d.f.) = 44.8604 %; Standard Error of Est. = 1.05014; Mean absolute error = 0.719889; Durbin-Watson statistic = 2.683 (P=0.7873); Lag 1 residual autocorrelation = -0.390054), indicate a moderately strong relationship between the variables and since the P-value is greater than 0.05, there is no indication of serial autocorrelation in the residuals at the 95.0% confidence level.

**Table 4** The coefficients and analysis of variance for relation  $N=f(NE)$ , for group 1071

Coefficients					
Parameter	Least Squares Estimate	Standard Error	T Statistic	P-Value	
Intercept	-1.28379	0.858487	-1.49541	0.1732	
Slope	0.00132817	0.000460399	2.88482	0.0204	
Analysis of Variance					
Source	Sum of Squares	Df	Mean Square	F-Ratio	P-Value
Model	9.17766	1	9.17766	8.32	0.0204
Residual	8.82234	8	1.10279		
Total (Corr.)	18.0	9			

For the analysis regarding relationship  $D=f(NE)$  in the group 1071, in the same conditions and fitted model as previous, the results indicated the optimum equation of the fitted model:

$$D = -26.5196 + 0.0287988 \cdot NE.$$



**Figure 4** Plot of the fitted model for relation  $D=f(NE)$ , group 1071

In Figure 4 can be seen the position in graphic and in Table 5 the results for coefficients and analysis of variance. In the last situation, the statistic parameters (Correlation Coefficient = 0.701035; R-squared = 49.1449 %; R-squared (adjusted for d.f.) = 42.7881 %; Standard Error of Est. = 23.6249), indicated a moderately strong relationship between the variables and there is no indication of serial autocorrelation in the residuals at the 95.0% confidence level.



**Table 5** The coefficients and analysis of variance for relation  $D=f(NE)$ , for group 1071

<b>Coefficients</b>					
<i>Parameter</i>	<i>Least Squares Estimate</i>	<i>Standard Error</i>	<i>T Statistic</i>	<i>P-Value</i>	
Intercept	-26.5196	19.3133	-1.37313	0.2070	
Slope	0.0287988	0.0103576	2.78046	0.0239	
<b>Analysis of Variance</b>					
<i>Source</i>	<i>Sum of Squares</i>	<i>Df</i>	<i>Mean Square</i>	<i>F-Ratio</i>	<i>P-Value</i>
Model	4314.93	1	4314.93	7.73	0.0239
Residual	4465.07	8	558.13		
Total (Corr.)	8780.00	9			

## CONCLUSIONS

This study is an initial step to analyse the incidence of injury in the sector of food industry in Timis County and a base for future extending in Romania. Seriously injuries were observed almost in group of activities CAEN 1011 and 1071. A moderately strong relationship between number of employees and number of accidents, but not a statistically significant relationship at the 95.0% or higher confidence level for S-curve model was observed, but for the same model, relatively weak relationship between the number of employees and number of days of temporary inability at work was observed. For the group of activities Caen 1071, the most adequate was linear regression model, with a moderately strong relationship between number of employees and number of accidents, but no indication of serial autocorrelation at the 95.0% of higher confidence level and similarly for the relationship between the number of employees and number of days of temporary inability at work. All results indicated strong disparities between OHSRMS and the possibility to reduce the accident rate at work by efficient measures and limitation of the access of workers in danger areas and weak motivation for OHSRMS. The method end results could be used for evaluation of such management systems by using specific Key Performance Indicators (Tucu et al., 2021b). Further research needs to analyse the comparative evolution at enterprises level and at national level in the food industry, along with investigation of the psychosocial factors on the workers.

## REFERENCES

- Bodescu, D., Robu, A.-D., Jiřareanu, A.F., Puiu, I., Gafencu, A.M., Lipşa, F.D. (2022). Work Satisfaction in the Food Industry—A Premise for Economic Performance. In: Agriculture. 12, 1015. <https://doi.org/10.3390/agriculture12071015>
- Clayton, M., Smith, C., Rutkow, L. (2016). U.S. Food System Working Conditions as an Issue of Food Safety: Key Stakeholder Perspectives for Setting the Policy Agenda. In: New solutions: A Journal of Environmental and Occupational Health Policy 26 (4), pp.599-621.

- Crisan, G.C., Tucu, D., Boboescu, R. (2017). Improvement of safe & healthy work systems in agricultural SME's. In: Actual Tasks on Agricultural Engineering-Zagreb, vol.45, 657-663
- Gusetoiu, I.R., Tucu, D. (2012). Influence of occupational stress in jobs in the field of nanomaterials. In: Tanger Ltd. Conference: 4th International Conference on NANOCON, Brno, Czech Republic, 531-536
- Gusetoiu, I.R., Tucu, D. (2013). Stress risk in management systems in metallurgical problems. In: Tanger Ltd. Conference: 22nd International Conference on Metallurgy and Materials (METAL), Brno, Czech Republic, 1904-1908
- Jadhav, R., Achutan, C., Haynatzki, G., Rajaram, S., Rautiainen, R. (2015). Risk factors for agricultural injury: a systematic review and meta-analysis. *J. Agromed.* 20, 434–449.
- Jadhav, R., Achutan, C., Haynatzki, G., Rajaram, S., Rautiainen, R. (2016). Review and meta-analysis of emerging risk factors for agricultural injury. *J. Agromed.* 21, 284–297
- Jemai, H., Badri, A., Ben Fredj, N. (2021). State of the Art and Challenges for Occupational Health and Safety Performance Evaluation Tools. *Safety* 2021, 7, 64. <https://doi.org/10.3390/safety7030064>, accessed September 2022.
- Kaassis, B.; Badri, A. (2018). Development of a preliminary model for evaluating occupational health and safety risk management maturity in small and medium-sized enterprises. *Safety* 4(1), 5; <https://doi.org/10.3390/safety4010005>, accessed September 2022
- Mitchell, R., Lystad, R. (2019). Occupational injury and disease in the Australian aquaculture industry. *Marine Policy* 99, 216–222
- Tatenda, M., Pedzisai, K. (2022). Effects of occupational health and safety management systems implementation in accident prevention at a Harare beverage company, *Cogent Engineering*, 9:1, 2124638, <https://doi.org/10.1080/23311916.2022.2124638>, accessed October 2022
- Tucu, A., Crisan, G.C., Tucu, D., Vasilica, A. (2021a). Motivational factors in systems of occupational risk management in agriculture. In: Actual Tasks on Agricultural Engineering, Zagreb, Vol. 48, 521-526
- Tucu, A., Purcarea, A.A., Crisan, G.C., Vasilica, A., Tucu, D. (2021b). Quality evaluation of occupational health & safety (OHS) risk management systems from agriculture. In: Book Series: Actual Tasks on Agricultural Engineering-Zagreb, vol.48, 527-534
- Tucu, D., Crisan, G.C., Tucu, A. (2019). The use of self-assessment in occupational risk management system in SMEs from agriculture. In: Book Series: Actual Tasks on Agricultural Engineering-Zagreb, vol.47, 479-485
- \*\*\* CAEN. (2022). Oficiul National al Registrului Comertului. Nomenclator CAEN. <https://www.onrc.ro/index.php/ro/caen-index?cod=105>, accessed October 2022.
- \*\*\*, ESENER. (2022). Third European Survey of Enterprises on New and Emerging Risks (ESENER 2019): Overview Report, How European workplaces manage safety and health. European Agency for Safety and Health at Work, Luxembourg: Publications Office of the European Union, ISSN 1831-9343, 7-8



## OCCUPATIONAL RISK MANAGEMENT BY SYSTEMS ERGONOMICS IN MANUFACTURING OF ICE CREAM STICKS

Rudolf MIRESCU<sup>1</sup>, Alexandru TUCU<sup>2</sup>, Bogdan Raul MIRCEA<sup>1</sup>, Dumitru TUCU<sup>1\*</sup>

\*E-mail of corresponding author: dumitru.tucu@upt.ro

<sup>1</sup>Mechanical Machines and Transportation, Politehnica University Timisoara,  
No.1, Mihai Viteazu Av., RO-300011 Timisoara, Romania

<sup>2</sup>Faculty of Entrepreneurship, Business Engineering and Management,  
Politehnica Univ., no.313, Spl. Independentei, Sect.6, Bucuresti, RO-060042

### ABSTRACT

*The paper presents the results of evaluating the levels of risk and hazard regarding security in work and professional diseases, based on systems ergonomics and adequate proposed prevention and correction actions. Starting at the method elaborated by the National Directorate of the Renault Plants – France an evaluation process was initiated at Smart Wood Romania SRL, as part of management system for occupational risk (MSOR), firstly regarding muscle-skeletal occupational diseases. 27 evaluation criteria, grouped in 8 factors (A-H), from 4 domains were evaluated on 5 ergonomic levels (level 1- the most favourable to 5- the most unfavourable). The evaluation process was contained 4 steps: data collection, level risk assessment, designing of global and analytic risk profile and proposal of prevention and corrective actions. After analyse of global risk profile, especially A2 (supplying and evacuation of pieces), B6 (thermal environment (ambiance)) and B7 (noise ambiance) a set of actions was proposed and implemented. As consequences, after the implementation of actions the rate of work accidents has decrease to zero, and, also the number of days of medical inability to work, even the number of employees increased. The experience and results of present work can be generalized and used, also, in other enterprises from food industry.*

**Keywords:** Ergonomic risk assessment, ice cream stick manufacturing, risk profile, corrective actions, optimization

### INTRODUCTION

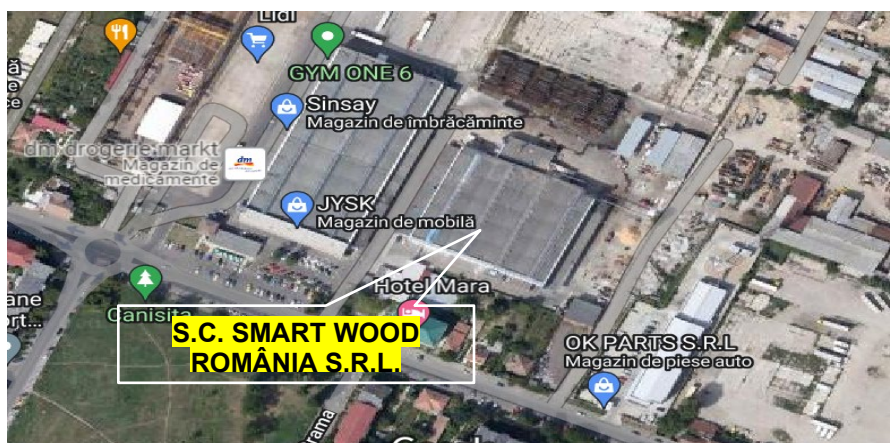
In management of systems for occupational risk (MSOR), the ergonomic risk assessment actually becomes one of the most important risk evaluation activities, especially in

manufacturing areas (Delice and Can, 2020). Having the goal to identify the ergonomic risk level for the workers such activity provides healthy, fit, engaged workforce and a workplace that is designed to encourage maximum human performance. Since the causes are multifactorial and involve personal, physical job, identifying of the causes of ergonomic risks is a hard work in conditions of factors and workplace psychosocial characteristics (Lu et al., 2014). If such risk assessment is applied to multiple workers, a multi-criteria decision making (MCDM) structure is necessary because more workers are evaluated in terms of different and conflicting ergonomic risk criteria (Bera et al. 2020). The general objective of risk assessment remains improving of the occupational health and safety risk management system. Almost in the food and wood industry the importance increase because the perception of risk factors, almost consequences, still remaining at low level (Tucu et al., 2019; Bodescu et al., 2022; Tucu et al., 2021). In such conditions the hazardous activity from industry and high rate of injuries (Jadhav et al., 2015; Jadhav et al., 2016), imposes preventive activities and actions specifically to enterprises safety. Also, conflicting situations can appears, the evaluation and selection process involved to be handled with an MCDM and functional approach relatively to manufacturing system and automation of the work process (Babanatis Merce et al., 2018). The opportunity of such interest can be argued by the cost of the Work Muscle Skeletal Disorders (WMSD) in the European Union, estimated at least on 150 billion euros per year (Octavio et al., 2019).

The objective of present paper, based on author's previous experience in the frame of legal authority requirements, was to account and hierarchize the significant hazard and factors for security and health in work, based on systems ergonomics, by implementing at Smart Wood Romania S.R.L.

## METHODS

The object of study was S.C Smart Wood România S.R.L., situated in Timisoara, Romania (the position of manufacturing facility can be seen in figure 1 (processing after Google Maps)).



**Figure 1** Position of manufacturing facility

As representatively was considered section „Selection”, workplace „selection & packaging at MAG72 machine”. The risk assessment process was developed in the first half of 2020 year using R.N.U.R. method assessment based on ergonomic criteria, method developed at the National Administration of Renault Plants, France (Vasiliu and Bordei, 2013). The evaluation process contained 4 steps: data collection, level risk assessment, designing of global and analytic risk profile and proposal of prevention and corrective actions. After job description analysis was proceeded to collect data’s about manufacturing process, position of equipment and facilities at workplace (machines, access roads, furniture, windows and doors), light, etc., noise, and supplementary questionnaires. Based on such information the risks levels were determined for each of 27 influence criteria, grouped in 8 risk factors and 4 topics. Following the obtained values, the analytic (for all 27 criteria in 8 groups) and global profile (summarized on each 8 groups) were designed. Each criterion was evaluated on 5 ergonomic levels (from level 1- the most favourable to 5- the most unfavourable). For noise measurement was used a sound meter DeltaOhm HD2010UC.Kit2. Based on final results improvement measures were proposed and implemented.

## RESULTS AND DISCUSSION

In table 1 are described the levels values for all 27 criteria, and 8 groups.

**Table 1** Evaluated levels values for all 27 criteria, and 8 groups

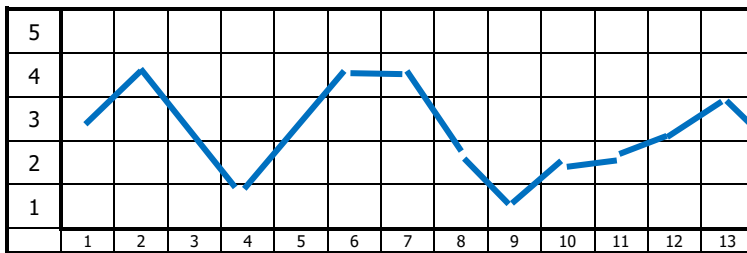
No	Criteria	Level value	No	Criteria	Level value
A1	Work surface level Height, Distance	3	C15	Work position	2
A2	Supplying, Height Evacuation, Distance	5	C16	Handling effort	2
A3	Crowding – Accessibility	3	C17	Position during handling	2.5
A4	Commands - Signals	1	D18	Mental operations	2.5
A5	Work safety	3	D19	Level of attention	3
B6	Thermal environment	4	E20	Individual	2
B7	Ambient noise	4	E21	Group	3
B8	Artificial lighting	1	F22	Independent of work	4
B9	Vibration	1	F23	Addicted to work	3
B10	Atmospheric hygiene	2	G24	Repetitiveness of the work cycle	2
B11	Appearance of the post	2	H25	Potential	3
C12	The main position	2.5	H26	Responsibility	3
C13	The most unfavorable position	3	H27	Interest in work	4
C14	Work effort	2			

For assessment of B7 criteria level (ambient noise), the measured level of noise pressure was 89,9 dB(A) and the value were compared with standard recommendation (table 2).

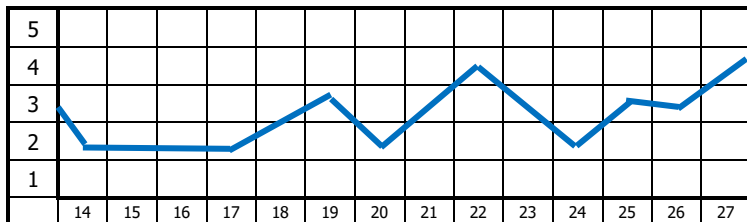
**Table 2** Level and values recommended by standard method

Intensity in dB(A)	≤55	56-70	71-85	86 - 100	>100
Level granted	1	2	3	4	5

The analytic profiles for all 27 criteria are presented in figure 2 a (first 13 criteria) and b (last 14 criteria).



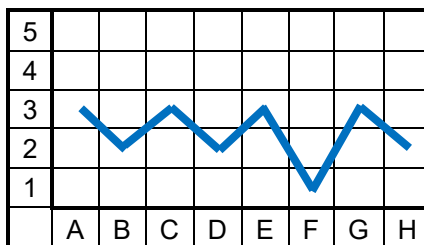
a.



b.

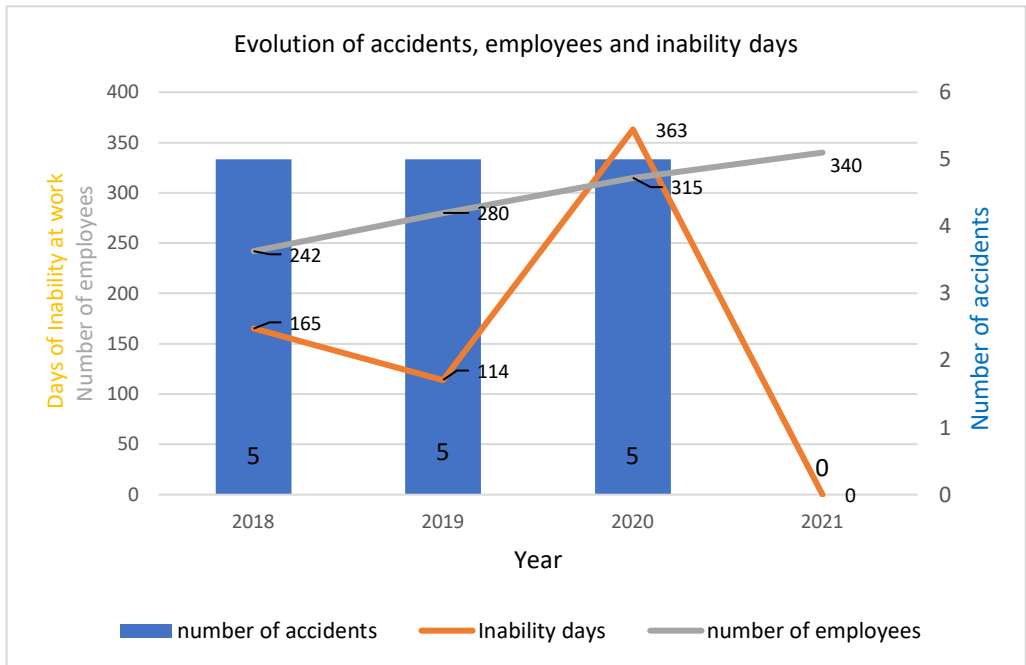
**Figure 2** The analytic profile

The global profile, summarized for all 8 groups are presented in figure 3.



**Figure 3** The global profile

From the analysis of analytic and global profile the management took decisions to improve A2, B6 and B7 criteria by next actions: to eliminate the handling of bulk pack boxes in control area; supplying boxes by handling trolley; eliminating of manual palletizing; ensuring the thermal environment in summer days; decreasing of noise level. All corrections actions were implemented at the end of 2020 year. The statistic regarding work events (incidents) on 2021 year is presented in figure 4. The results show the strongly positive effect of measures implemented according to the results of risk assessment, even the increasing of employees' number. As shown, the use of ergonomic methods in management practice to evaluate hazard risks, can be good scientifically resources in workplaces for minimizes the losses related to accidents and occupational diseases (Oliveira et al., 2018; Gul, 2018; Crisan et al., 2017).



**Figure 4** The impact of implemented measures according to risk assessment

## CONCLUSIONS

This paper presents the results of ergonomic risk assessment by R.N.U.R. method assessment based on ergonomic criteria one of the important assessment methods in the frame of systems ergonomic. The objective proposed was to identify the worker(s) with the highest ergonomic risk level. The proposed method for ergonomic risk assessment can provides many advantages for the risk analysis related to the workers and identification of adequate corrective actions. The use of ergonomic methods in management practice, arising in or from workplace, minimizes the losses related to work accidents and occupational diseases.

## REFERENCES

- Babanatis Merce, R.M., Babanatsas, T., Maris, S., Tucu, D., Ghergan, O.C. (2018). Study of an automatic olives sorting system. In: *Actual Tasks on Agricultural Engineering*, Zagreb, Vol. 46, 485-490
- Bera, A.K., Janab, D.K., Banerjee, D., Nandy, T. (2021). A group evaluation method for supplier selection based on Interval Type-2 fuzzy TOPSIS method. *Int J Bus Perform Supply Chain Model*, [https://www.researchgate.net/publication/363444050\\_A\\_group\\_evaluation\\_method\\_for\\_supplier\\_selection\\_based\\_on\\_interval\\_type-2\\_fuzzy\\_TOPSIS\\_method](https://www.researchgate.net/publication/363444050_A_group_evaluation_method_for_supplier_selection_based_on_interval_type-2_fuzzy_TOPSIS_method), accessed September 2022
- Bodescu, D., Robu, A.-D., Jiřareanu, A.F., Puiu, I., Gafencu, A.M., Lipşa, F.D. (2022). Work Satisfaction in the Food Industry—A Premise for Economic Performance. In: *Agriculture*. 12, 1015. <https://doi.org/10.3390/agriculture12071015>, accessed October 2022
- Crisan, G.C., Tucu, D., Boboescu, R. (2017). Improvement of safe & healthy work systems in agricultural SME's. In: *Actual Tasks on Agricultural Engineering-Zagreb*, vol.45, 657-663
- Delice, E.K., Can, G.F. (2020). A new approach for ergonomic risk assessment integrating KEMIRA, best-worst and MCDM methods. *Soft Computing*, Vol. 24 Iss. 19, 15093-15110.
- Gul, M. (2018). A review of occupational health and safety risk assessment approaches based on multi-criteria decision-making methods and their fuzzy versions, *Hum. Ecol. Risk Assess.* 24 (7), 1723–1760
- Jadhav, R., Achutan, C., Haynatzki, G., Rajaram, S., Rautiainen, R. (2015). Risk factors for agricultural injury: a systematic review and meta-analysis. *J. Agromed.* 20, 434–449.
- Jadhav, R., Achutan, C., Haynatzki, G., Rajaram, S., Rautiainen, R. (2016). Review and meta-analysis of emerging risk factors for agricultural injury. *J. Agromed.* 21, 284–297
- Lu, M.L., Waters, T.R., Krieg, E., Werren, D. (2014). Efficacy of the revised NIOSH lifting equation to predict risk of low-back pain associated with manual lifting: a one-year prospective study. *Hum Factors* 56(1):73–85
- Octavio, L.M.F., Javier, D.B.E., Vidal, A.T.O., Gerardo, M.P. (2019). Proposal of a Guide to Select Methods of Ergonomic Assessment in the Manufacturing Industry in Mexico. *Advances in Intelligent Systems and Computing*, Vol. 825, 301-309
- Oliveira, M.D., Lopes, D.F., Bana e Costa, C.A. (2018). Improving occupational health and safety risk evaluation through decision analysis, *Int. Trans. Oper. Res.* 25 (1), 375–403,
- Tucu, A., Crisan, G.C., Tucu, D., Vasilica, A. (2021). Motivational factors in systems of occupational risk management in agriculture. In: *Actual Tasks on Agricultural Engineering*, Zagreb, Vol. 48, 521-526
- Tucu, D., Crisan, G.C., Tucu, A. (2019). The use of self-assessment in occupational risk management system in SMEs from agriculture. In: *Book Series: Actual Tasks on Agricultural Engineering-Zagreb*, vol.47, 479-485
- Vasiliu, A., Bordei, M. (2013). Method of Risk Assessment Based on Ergonomic Criteria. Case Study: Crane Maintenance Electrician. *The Annals of “Dunarea de Jos” University of Galati. Fascicle IX, Metallurgy and Materials Science* 36(1):84-1, <https://www.gup.ugal.ro/ugaljournals/index.php/mms/article/view/2857>, accessed October 2022





## PERCEPTION OF CONTROL IN MOTIVATING COMPLIANCE WITH OHS REQUIREMENTS IN RURAL SMEs

Alexandru TUCU<sup>1</sup>, Anca-Alexandra PURCĂREA<sup>1</sup>, George Catalin CRISAN<sup>2</sup>, Vlad MĂRĂZAN<sup>3</sup>, Dumitru TUCU<sup>4\*</sup>

\*E-mail of corresponding author: dumitru.tucu@upt.ro

*Faculty of Entrepreneurship, Business Engineering and Management,  
Politehnica Univ., no.313, Spl. Independentei, Sect.6, Bucuresti, RO-060042  
<sup>2</sup>S.C. PROMUN S.R.L., Arad, Romania*

<sup>3</sup>*Department of Overland Communication Ways, Foundation and Cadastral Survey,  
Politehnica University Timisoara, No.1A, Ioan Curea Str., RO-300224 Timisoara, Romania,*

<sup>4</sup>*Mechanical Machines and Transportation, Politehnica University Timisoara,  
No.1, Mihai Viteazu Av., RO-300011 Timisoara, Romania*

### ABSTRACT

*Framed in assessment and general optimization process of occupational health and safety risk management system (OHSRMS) of small and middle enterprises (SMEs) from rural area, the paper has the main objective to analyse the perception of the importance of controls – both management and legal authority controls (ITM) - at different enterprises and workers categories. It estimated to support the identification of the adequate processes, actions and instruments for increase the perception of importance of controls as factor for the process of optimization OHSRMS in micro- ( $\mu$ E) and small enterprises (SE), in rural economic environment. Starting from former evaluation of the disparities regarding the perception of control from legal authorities (from personal experience and bibliography), and considering it as part of motivational extrinsic factors regarding OHS, the research is based on 141 online (Google) questionnaires including 20 questions about perception and quotation of different OHS factors, distributed in different specific activities and dimensions, from Arad and Timis county, West of Romania. Different categories of employees were considered: representatives of management and owners (also both, workers, and specialist in OHS. After data collecting from questionnaires, and statistically proceeding, analysis of the results concluded that 75 % from employees has information about ITM control and 90 % of them consider the positive function of OHS penalties. More than 55 % from respondents evaluated the general interest for management controls importance as high and very high, at the median value 4, with acceptable value*

*for standard deviation. Even, more than 6 % did not answer to the question, more than 66,66 % (2/3) consider at high and very high level that a digital (IT&C) training can create the permanent control possibilities for management, in verified condition of statistic relevance demonstrated using One-Way ANOVA analysis. Also, could exist a trend of influence of independent variables “age of respondents” on the perception as motivational factor.*

**Keywords:** *occupational health and safety risk management system, SMEs, legal authority control, motivation, optimization*

## INTRODUCTION

According to „Third European Survey of Enterprises on New and Emerging Risks (ESENER, 2019): Overview Report”, despite the introduction of measures to address musculoskeletal disorders (MSD), they have not decreased the number over the period from ESENER 2014 to ESENER 2019. Also, measures to manage psychosocial risks were not widespread among establishments. Such situations suggests that the EU Directive on Safety and Health at Work (European Commission, 2014) must play a significant role and encourage the use of all measures to manage occupational health and safety (OSH).

The perception regarding risk factors, both probabilities and consequences, still remaining different, in correlation with field of activities, structure and functions of Occupational Health & Safety Risk Management Systems (OHSRMS), and the dimensions of enterprises (Gusetoiu and Tucu, 2012; Gusetoiu and Tucu, 2013; Tucu et al., 2019, respectively, Darabont et al., 2018; Crisan et al., 2017; Hasle and Limborg, 2006).

Smaller organisations in EU agriculture (especially micro- establishments), (small enterprises of family farms where 77% of labour force in 2013 consisted of sole holders or family members, according to Eurostat, 2016), presents great discrepancies, different sizes for most of the OSH management measures (Kari and Gro, 2018).

One factor, involved in all situations, is the worker satisfaction and perception of own importance and position (Bodescu et al., 2022).

The hazardous activity from agriculture and high rate of injuries (Jadhav et al., 2015; Jadhav et al., 2016), needs great efforts for preventive efforts in conditions of multifactorial farm safety actions and performing of their systematic review. Such actions must be integrated in state policy, governments having allocated considerable resources to enhance work safety conditions, either through specific policies or investments among competing businesses (Esteban and Jesus, 2021).

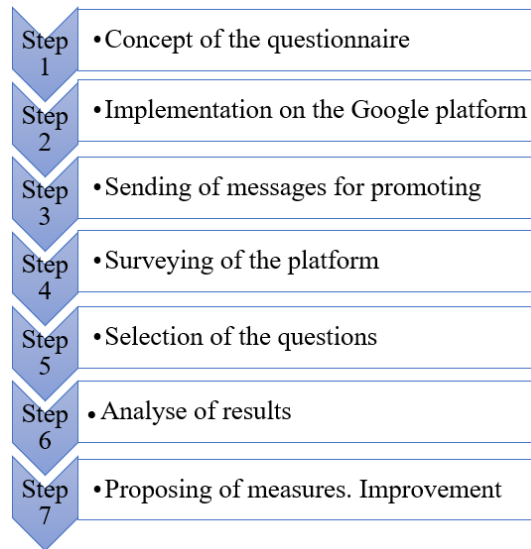
Having both particularities, small and high rate of injury risk, agricultural enterprises require more assistance from external bodies as government, local authorities, insurance and dedicated external services than larger companies (Hasle et al., 2012; Sinclair et al., 2013).

Based on author’s previous experience, the paper has the main objective to analyse the efficiency effects and the importance of legal authority/management controls at different workers categories. Such objective can contribute to identification of the actions and instruments for increasing the process of optimization OHSRMS.

## METHODS

Based on former experience (Tucu et al., 2019; Tucu et al., 2021), an interest regarding OHS control was suggested. The concrete objective of this paper was to analyse in parallel the perception of management control and ITM control at various positions (worker, management, positions in the same time management and owner, OHS specialist and/or consultant etc.).

The methodological steps proposed by authors are successively presented in figure 1.



**Figure 1** Methodological steps

The aim of the questionnaire was to collect information regarding OHSRMS of SME from rural area. 500 e-mails were sent to different persons from rural area. In the period December 2021 - February 2022 a number of 141 persons answer to the questions. The questionnaire was uploaded as online form in Google Forms (part of Google Workspace), accessed by Google drive, and was accessible to the invited people by an E-mail invitation.

According to the subject of present paper, next questions were selected for analyse:

- The SME topics;
- The respondent positions;
- The respondent ages;
- Familiarity of ITM (local OHS authority responsible) control concept;
- Opinion about negative effect of fines (penalties);
- Evaluation of management controls importance;
- The interest regarding work stress;
- The opinion regarding a digital training and control possibilities.

Questions regarding evaluation of management controls importance and opinion regarding a digital training needed a qualification on five levels from 1 (lowest) to 5 (highest). Regarding perception of investment in control and accounting in occupational health, next fifth level were used: not exist, low, constant, breeder (increasing) and biggest. The selected results were statistic analysed using Microsoft Excel 2016 and STATGRAPHICS Centurion. Based on discussions and conclusions, measured for OHSRMS improvement and optimisation were proposed.

## RESULTS

Table 1 presents the results regarding the share of enterprises topic. For better interpretation all services sectors were grouped also at position 2 (this explains the number of answers exceed 141).

The number of persons cumulated at total service (poz.2 in table) was not considered in figure 3.

**Table 1** Results of enterprise's sharing

No.	Topic	Number	Share, [%]	No.	Topic	Number	Share, [%]
1	Manufacturing	50	35.4609929	14	Teaching	2	1.418439716
2	Total services except OHS	41	29.0780141	15	Waste management	2	1.418439716
3	OHS services consultancy	13	9.21985815	16	Police	1	0.709219858
4	Transport & logistic	11	7.80141844	17	Food production	1	0.709219858
5	Build activities	10	7.09219858	18	Human resources	1	0.709219858
6	IT	9	6.38297872	19	Cleaning services	1	0.709219858
7	Information and communication services	8	5.67375886	20	Engineering and design services	1	0.709219858
8	Retail	7	4.96453900	21	Environment services	1	0.709219858
9	Financial intermediation services, insurance	5	3.54609929	22	Programming/developing services	1	0.709219858
10	Farm production	5	3.54609929	23	Special inspections services	1	0.709219858
11	Hotels, restaurants	3	2.12765957	24	Sales of consumer goods	1	0.709219858
12	Health& social assistance	3	2.12765957	25	Administration of houses	1	0.709219858
13	Immobilierary services	3	2.12765957				

Analysing the topic sharing of enterprises, could be concluded more than 60 % from respondents comes from enterprises from manufacturing and services. This is due the displacement of more plants for manufacturing in rural area thanks to facilities and fiscal policies. Also, usually, based on former authors studies (Crisan et al., 2017; Tucu et al., 2021 etc.), the lever of workers qualifications in such areas is better than farm agriculture. The topic sharing include also few jobs typical for rural area, demonstrating the spread area of distributed questionnaire.

Table 2 presents the respondent’s topic’s sharing and table 3 their ages according to the answers (only 83 from 141, 58 persons did not answer).

Regarding familiarity of ITM (local OHS authority responsible) control concept, from other 14 OHS concepts, 102 persons from 141 mentioned they are familiar ITM control (72,3 %, the fifth position in hierarchy).

**Table 2** Respondents topic’s sharing

No.	Topic	Number	Share, [%]	No.	Topic	Number	Share, [%]
1	Employees in administrative/ economic, etc.	26	31.70732	8	Sales representative	1	1.219512
2	Management	19	23.17073	9	Auditor	1	1.219512
3	Manager and Owner	14	17.07317	10	QA - quality assurance (Testing)	1	1.219512
4	Consultant/ specialist OHS	5	6.097561	11	IT Administrator	1	1.219512
5	Team Leader	4	4.878049	12	IT Engineer	1	1.219512
6	Owner	4	4.878049	13	School psychologist	1	1.219512
7	Work in manufacturing storage	3	3.658537	14	Quality Engineer	1	1.219512

**Table 3** Respondents’ age

No.	Topic	Number	Share, [%]
1	Under 25 years	2	2.40964
2	Between 25-39 years	46	55.42169
3	Between 40-65 years	34	40.96386
4	Over 65 years	1	1.20481

At question regarding actions with negative effect on OHS, the negative effect of fines (penalties) was mentioned by 10 respondents (7,1 %, position 12 in hierarchy from 14 options), that means more than 90 % consider fines with positive function on OHS.

Regarding the most inquiry factors at work, stress at work was included in 23 answers (16,3 %, position 9 in hierarchy), that demonstrate low knowledge about stress at work in rural area.

At question regarding evaluation of general interest for management controls importance, the answers received evaluated the importance between 1 to 5, the median value was 4 and standard deviation 1.19444. 34 answer evaluated interest for management control at level 5 (24,11 %), 43 answers at level 4 (30,49), 39 answers at level 3 (27,66 %), 13 answers at level 2 (9,22 %) and 12 answers at level 1 (8,51 %).

Table 4 presents the results of One-Way ANOVA analysis about relation between age (the four groups presented in Table 3, encoded 1,2,3, respective 4) and collected answers.

The conclusion is  $F_{\text{statistic}} > F_{\text{critical}}$  value, the test is significant and because  $p < 0,05$ , the alternative hypothesis is valuable, was statistical demonstrated there is a difference between the means of groups.

**Table 4** One-Way ANOVA for relation between age and perception of managerial control

<b>Summary</b>						
<i>Groups</i>	<i>Count</i>	<i>Sum</i>	<i>Average</i>	<i>Variance</i>		
Age	83	200	2.409639	0.317955		
Management control	83	300	3.614458	1.239788		
<b>Anova</b>						
<i>Source of Variation</i>	<i>SS</i>	<i>df</i>	<i>MS</i>	<i>F</i>	<i>P-value</i>	<i>F crit</i>
Between Groups	60.2409	1	60.24096	77.3439	1.89E-15	3.898787
Within Groups	127.7349	164	0.77887			
<b>Total</b>	<b>187.9759</b>	<b>165</b>				

The analysis of opinion regarding a digital (IT&C) training and permanent control possibilities shows that 61 answers consider it brings very high benefits (43,26 %), 33 answers high benefits (23,4 %), 22 answers medium benefits (15,6 %), 8 low benefits (5,67 %) and 8 very low benefits (5,67 %). (9 respondents did not feel themselves qualified for answer). One-Way ANOVA analysis for relation between age and perception of benefits of a digital (IT&C) training and permanent control possibilities is similarly perception of managerial control:

$F_{\text{statistic}} = 47,75566 > F_{\text{critical}} = 3.03251$  and  $p\text{-value} = 2.993578E-18 < 0,005$ , also the alternative hypothesis is valuable, and statistical was demonstrated there is a difference between the means of groups.

## CONCLUSIONS

Analysing the results can be concluded that the structure of employees is conformed with the structure and actual trends in rural area. Almost 75 % from employees have information about ITM control and 90 % of them consider the positive function of OHS penalties. More than 55 % from respondents evaluated the general interest for management controls importance as high and very high, at the median value 4, with acceptable value for standard deviation. Even, more than 6 % did not answer to the question, more than 66,66 % (2/3) consider at high and very high level that a digital (IT&C) training can create the permanent control possibilities for management, in verified condition of statistic relevance demonstrated using One-Way ANOVA analysis.

Could exist a trend of influence of independent variables “age of respondents” on the perception as motivational factor.

Such conclusion imposes few measures: introduction in the program of future trainings of supplementary explanations regarding stress at work; for improving of perception must keep the introduction in the program of future ITM controls of official meeting between control team and workers and simplification of ITM control procedures, including adaptation to the specific conditions of rural environment.

## REFERENCES

- Bodescu, D., Robu, A.-D., Jiřareanu, A.F., Puiu, I., Gafencu, A.M., Lipsa, F.D. (2022). Work Satisfaction in the Food Industry—A Premise for Economic Performance. In: *Agriculture*. 12, 1015. <https://doi.org/10.3390/agriculture12071015>
- Crisan, G.C., Tucu, D., Boboescu, R. (2017). Improvement of safe & healthy work systems in agricultural SME's. In: *Actual Tasks on Agricultural Engineering-Zagreb*, vol.45, 657-663
- Darabont, D.C., Bejinariu, C., Ionita I., Bernevig-Sava M.A., Baciuc C., Baciuc E.R. (2018). Considerations on improving occupational health and safety performance in companies using ISO 45001 Standard. *Environmental Engineering and Management Journal*, Vol.17, No. 11, 2711-2718
- Esteban, L., Jesús, A. (2021). Territorial efficiency: Analysis of the role of public work safety controls. *Safety Sci.* 134, <https://doi.org/10.1016/j.ssci.2020.105074>, accessed September 2022.
- Evaluation of an introductory course in occupational health and safety in Norway. *Safety Sci.* 109, 368-376
- Gusetoiu, I.R., Tucu, D. (2012). Influence of occupational stress in jobs in the field of nanomaterials. In: *Tanger Ltd. Conference: 4th International Conference on NANOCON*, Brno, Czech Republic, 531-536
- Gusetoiu, I.R., Tucu, D. (2013). Stress risk in management systems in metallurgical problems. In: *Tanger Ltd. Conference: 22nd International Conference on Metallurgy and Materials (METAL)*, Brno, Czech Republic, 1904-1908
- Hasle, P., Kvorning, L.V., Rasmussen, C.D., Smith, L.H., Flyvholm, M.-A. (2012). A model for design of tailored working environment intervention programmes for small enterprises. *Saf. Health Work* 3, 181–191
- Hasle, P., Limborg, H.J. (2006). A review of the literature on preventive occupational health and safety activities in small enterprises. *Ind. Health* 44, 6–12
- Jadhav, R., Achutan, C., Haynatzki, G., Rajaram, S., Rautiainen, R. (2015). Risk factors for agricultural injury: a systematic review and meta-analysis. *J. Agromed.* 20, 434–449.

- Jadhav, R., Achutan, C., Haynatzki, G., Rajaram, S., Rautiainen, R. (2016). Review and meta-analysis of emerging risk factors for agricultural injury. *J. Agromed.* 21, 284–297
- Kari, A.H., Gro, F. (2018). Making occupational health and safety training relevant for farmers: Intervention diffusion to small businesses. *Am. J. Ind. Med.* 56, 1442–1451
- Sinclair, R.C., Cunningham, T.R., Schulte, P.A. (2013). A model for occupational safety and health intervention diffusion to small businesses. *Am. J. Ind. Med.* 56, 1442–1451
- Tucu, A., Purcarea, A.A., Crisan, G.C., Vasilica, A., Tucu, D. (2021). Quality evaluation of occupational health & safety (OHS) risk management systems from agriculture. In: *Actual Tasks on Agricultural Engineering-Zagreb*, vol.48, 527-534
- Tucu, D., Crisan, G.C., Tucu, A. (2019). The use of self-assessment in occupational risk management system in SMEs from agriculture. In: *Actual Tasks on Agricultural Engineering-Zagreb*, vol.47, 479-485
- \* \* \*, ESENER. (2022). Third European Survey of Enterprises on New and Emerging Risks (ESENER 2019): Overview Report, How European workplaces manage safety and health. European Agency for Safety and Health at Work, Luxembourg: Publications Office of the European Union, ISSN 1831-9343, 7-8
- \* \* \*, European Commission. (2014). EU Strategic Framework on Health and Safety at Work 2014–2020. Communication from the Commission to the European Parliament, the Council, the European Economic and Social Committee and the Committee of the Regions, COM, 332.
- \* \* \*, ISO. (2018). ISO 45001:2018, Occupational health and safety management systems - Requirements with guidance for use. <https://www.iso.org/iso-45001-occupational-health-and-safety.html> , (accessed September 2020)





## SAFETY IMPROVEMENT OF INTEGRATED BIOMASS COMBUSTION SYSTEMS BY SIMULATION

Emil Călin KAZOMIR, Dumitru ȚUCU\*

\*E-mail of corresponding author: [dumitru.tucu@upt.ro](mailto:dumitru.tucu@upt.ro)

*Mechanical Machines and Transportation, Politehnica University Timisoara,  
No.1, Mihai Viteazu Av., RO-300011 Timisoara, Romania*

### ABSTRACT

*The paper proposes a solution to insure both the technological requirements concerning the efficiency of using the energy of biomass in furnaces for central heating, in conditions of the profitability and environmental protection, and insuring safety functional processes, especially in the power outages situations. In such conditions it appears necessary to continuously modify and optimize the existing burning systems. The article presents the results of research in designing and developing a new burner integrated system oriented towards designing a modern, innovative solution applicable to heating central in manufacturing burners for central heating boilers that will ensure high quality burning process biomass fuels (pellets and other bulky biomass) and high security level in function. Starting from intermediary proposed solution from design compartment, a succession of methodological steps was used for analyse and optimize the evolution of temperature field using 3D Thermal Analysis and Modeling simulations in Ansys 2022 R2. For burning space were considered three temperatures: 600, 800 and 1200 °C, and two situations of function: with fan air and pellets screw in function, and situation of power outages, when the fan system and pellet supplier stopped suddenly. Each from six simulation situations were carefully analysed for identification of critical thermal nodes and details for parts. Finally, a novel solution for biomass burner, integrated with other parts for insuring in function was proposed for exclude the risk of biomass unwanted ignition in any situation, inclusive the power outages.*

**Keywords:** *biomass combustion burner, simulation, power outages, design optimization*

## INTRODUCTION

In Romania, in 2021 year, for heating 1,2 million houses used centralized heating systems, 2,5 million houses used natural gas and about 3,5 million houses (almost in rural area), used solid fuel (wood biomass and coal), unfortunately burned in low efficiency and high pollution equipment (Ziarul Financiar, 2021). It means about 50 % from houses uses wood and other biomass for house heating. Opposite, in Europe, according to Eurostat 2021, in total gross production of derived heat in 2020 (amounted at 599 TWh ( $2,156 \times 10^{12}$  J (PW))), the shear of heat produced from solid fossil fuels (117 TW), (19,5 % of share) and renewable municipal waste (34,5 TW), cover more than 0,25 %. The trend of last years is to decrease (from 44,4 % in 2000), but in 2021 year it increases 10,7 %. On the other hand, Eurostat 2022 mentioned almost of the energy used by household is for heating the home (62,8 % of final energy consumption in residential sector). Electricity is used for lighting and most electrical appliances, about 14,5 %, excluding cooling and cooking. Corroborating with possible problems of gas share for heating, the importance of development, improving and optimization of (wood) and biomass combustion systems is justified.

Heating systems causes one-sixth of emissions EU (Fortum, 2021), and there are necessary adequate measures for achieve the EU objective of climate neutrality by 2050, i.e. a balance between carbon sinks and greenhouse gas emissions, in especially conditions of the trend in heating emissions not favorable. One important cause is low energy efficiency of installations for burning solid fuel, particularly based on outdated, traditional design (Huscio and Kowalewski, 2017). These causes excessive fuel consumption (coal, wood, biomass), usually greater than the demand for house useful energy (single family, group of costumers or public). Moreover, the incomplete burning process generate organic or non-organic carbon-graphite compounds, ash or soot particles, usually harmful for health (Gusetoiu and Tucu, 2013). One the other hand, as precised before, almost of such systems are in use in rural area, where the people have low levels of professional qualification, and generate high risks in exploitation (Crisan et al., 2017).

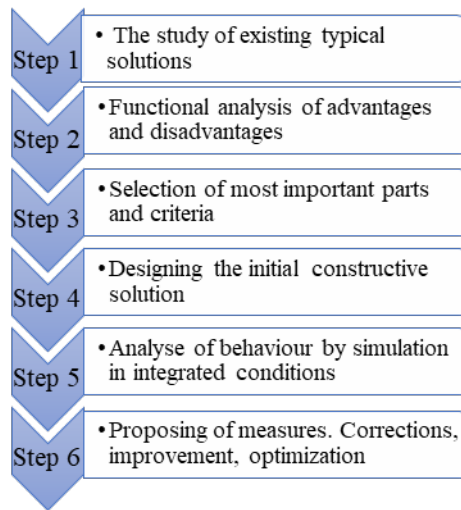
Based on this, results the condition for manufactures to design and implement modern burner designs for central heating, if possible, utilizing biomass as renewable energy resource. Also, appears the necessity to focus future actions on obtaining equipment capable to ensure high energy efficiency and environmental protection both high economic (cheap to use) and safety exploitation performances. It is normally to involve laborious „built and try” activities to result the best possible equipment configuration (Smith at al., 2020). More mathematic simulations of fuel burning, to calculate the combustion of biomass can help the future, can support part of experimental and applicative investigations (Irodov et al., 2021; Irodov et al., 2020). The present work applies different approach based on different possibilities, from the use of advanced shape optimization tools to investigate design optimization to simulation and reiteration (Smith, 1990; Horsman, 2010; Goel et al., 2008).

The paper proposes to design a new model for biomass burner using existing solutions by integrate few functional principles and burning options. The main objective of the paper is to analyse the existing solutions for biomass burners and propose an integrate solution together with supplying system and control unit. Connected there are secondary objectives as: simplicity of the solution, low costs in investment and maintenance and high capacity to assimilate in manufacturing. A comparative analysis by simulating few service situations was

made and redesign of few parts for optimizing also the safe and healthy use of equipment and its improvement measures and efficiency.

## METHODS

Starting from presented objectives, a succession of methodological steps was created for design the study's workflow included in present paper (figure 1, 3D model in CATIA V5 R30).



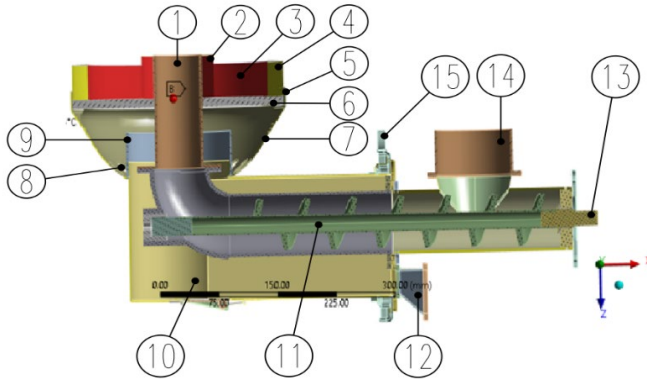
**Figure 1** Methodological steps

The first group of four steps was included in another research program. This paper presents the analysis of initial constructive solution for integrated burner resulted from these activities, based on intermediary design results presented in figure 2 (step 5, 6). The parts included in solution are: 1 – biomass supplying tube; 2 – internal refractory ring protection; 3 – burning space; 4 – external refractory ring; 5 – supporting ring; 6 – cast iron grill; 7 – ash harvester; 8 – hole ash evacuator; 9 – ventilation nozzle; 10 – air piping; 11 – pellets screw; 12 – fan support; 13 – engine coupling; 14 – supplying connector; 15 – heating system door.

Considering the proposed solution as initial structure, it was analysed the evolution of different parameters in particularly conditions using 3D Thermal Analysis and Modeling simulations in Ansys 2022 R2. The simulation has next objectives:

- account the temperature fluctuations,
- improve product reliability,
- ensuring environmental protection by the control the burning process,
- prevent overheating issues,
- optimize by integrated process, functions, costs, and safety.

Because the most important condition for such equipment was security in use and long life of materials and parts, the temperature, heat transfer and evolution of thermal field was considered the most important parameter, but correlated with cost of materials, manufacturing and quality costs.



**Figure 2** Integrated constructive solution (3D model in CATIA V5 R30) for biomass burner used in simulations

Three temperatures for burning space were considered: 600, 800 and 1200 °C, and two situations of function: with fan air and pellets screw in function, and situation of power outages, when the fan system and pellet supplier stopped suddenly.

All materials from parts were settled and/or introduced in the simulation program (if there are not in current use), also dimensions of fuel area in burner.

The dimension of finite elements was settled at 6 mm.

Each from six simulation situations were carefully analysed for identification of critical thermal nodes and details for parts. Finally, a novel solution for biomass burner, integrated with other parts for insuring in function were proposed.

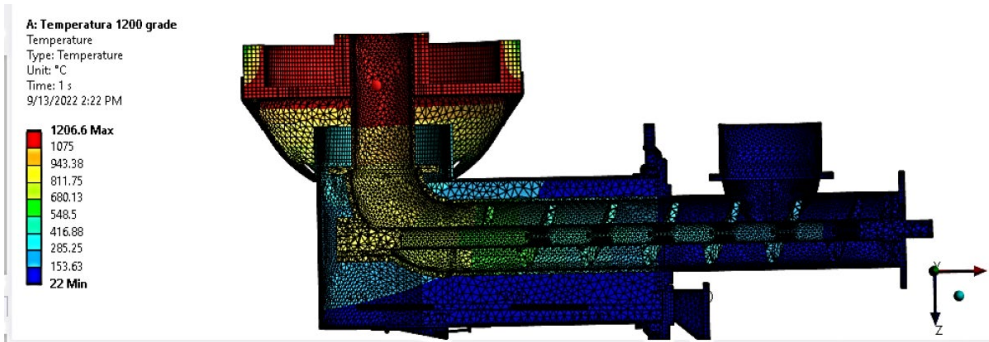
Because the most important section was the space for burning, in the second simulation process only the parts connected to burning chamber were considered. The conditions were similarly with the first part of the process excepting the dimensions of finite element: 4 mm.

The conclusions were selected for future applications.

## RESULTS

In figure 3 is presented the result of simulation process at pre-implementation research and development stage for power outages situation at 1200 °C burning temperature.

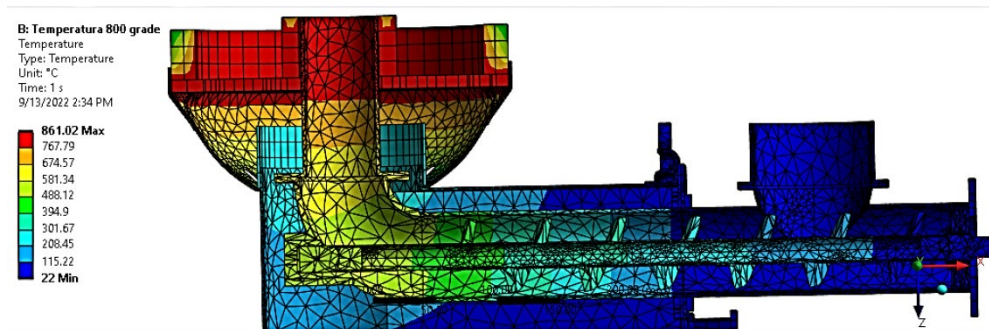
The critical area is the pipe for biomass supplying, where appears the risk for biomass uncontrolled inflammation and back evolution in supplying screw area (tube). Also, a critical node (pick of temperature), appears between external refractory ring, external supporting ring and cast iron grill.



**Figure 3** Simulation of power outage at 1200 °C burning temperature

A similar situation can be observed in the case of power outages simulation at 800 °C, but the temperatures level are lower and generates a low risk inflammation situation.

For reduce the security risks in situations of power outage, increase the burning performances of prototype burner, and synchronize the burner parameters with the control system functions the study continued with a high resolution simulation of critical zones and parts.



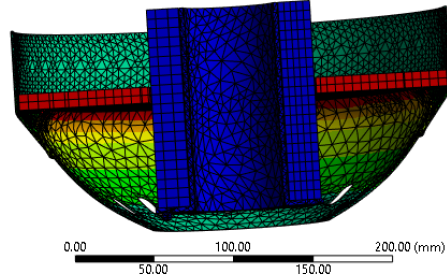
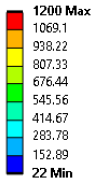
**Figure 4** Simulation of power outage at 800 °C burning temperature

The most important area (zone) is the burning system composed from (see figure 2): 1 – biomass supplying tube; 2 – internal refractory ring protection; 3 – burning space; 4 – external refractory ring; 5 – supporting ring; 6 – cast iron grill; 7 – ash harvester; 8 – hole ash evacuator.

Based of simulation observation, a new constructive solution was proposed by lengthening the internal refractory ring protection and testing, both another solution without external refractory ring and a higher supporting ring.

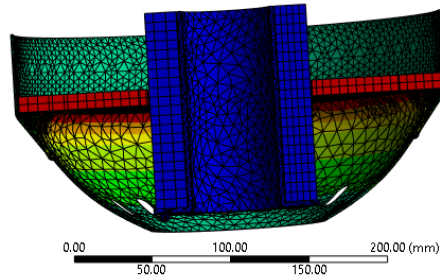
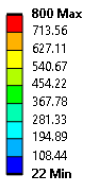
In figure 5 can be seen the simulation for upgraded burner in the power outage situation at 1200 °C burning temperature, and in figure 6 the same simulation at 800 °C burning temperature.

D: Geometrie redusa Temperatura 1200 grade  
 Temperature  
 Type: Temperature  
 Unit: °C  
 Time: 1 s  
 9/13/2022 2:43 PM



**Figure 5** Simulation for upgraded burner in the power outages situation at 1200 °C

C: Geometrie redusa Temperatura 800 grade  
 Temperature  
 Type: Temperature  
 Unit: °C  
 Time: 1 s  
 9/13/2022 2:37 PM



**Figure 6** Simulation for upgraded burner in the power outages situation at 800 °C

Principally, it is evident the similarity between observed situation in the case of power outage simulation at 1200 °C and 800 °C, but, of course, the temperatures level are lower in the second situation. Also, the proposed solution (long internal refractory ring protection) excludes the risk of biomass inflammation in any situation, inclusive power outages.

## CONCLUSIONS

The present work was oriented towards improving, by functional analysis the process of developing an innovative biomass burner for central heating boilers.

Improvement of biomass burner design, performance and safety, also connected to the development of the adequate control system can be seriously aided by the use of simulation program, general and oriented on most critical areas and parts.

As a result of the conducted research and work can be mentioned the necessity of simulation the power outage situation and solve the consequences for ensure the safety improvement.

The present proposed burner, by its dimensions, allow it to be installed in many solid fuel boilers.

For secure the intellectual property rights in this case, a patent application has been filed.

## ACKNOWLEDGEMENT

This article has been partially developed with support of S.C. AmbassadorPlus SRL, Timisoara Romania, manufacturer of biomass boilers.

## REFERENCES

- Hasle, P., Limborg, H.J. (2006). A review of the literature on preventive occupational health and safety activities in small enterprises. *Ind. Health* 44, 6–12.
- Jadhav, R., Achutan, C., Haynatzki, G., Rajaram, S., Rautiainen, R. (2015). Risk factors for agricultural injury: a systematic review and meta-analysis. *J. Agromed.* 20, 434–449.
- Jadhav, R., Achutan, C., Haynatzki, G., Rajaram, S., Rautiainen, R. (2016). Review and meta-analysis of emerging risk factors for agricultural injury. *J. Agromed.* 21,284–297.
- Gusetoiu, I.R., Tucu, D. (2012). Influence of occupational stress in jobs in the field of nanomaterials. In: *Tanger Ltd. Conference: 4th International Conference on NANOCON*, Brno, Czech Republic, 531-536.
- Gusetoiu, I.R., Tucu, D. (2013). Stress risk in management systems in metallurgical problems. In: *Tanger Ltd. Conference: 22nd International Conference on Metallurgy and Materials (METAL)*, Brno, Czech Republic, 1904-1908.
- Tucu, D., Crisan, G.C., Tucu, A. (2019). The use of self-assessment in occupational risk management system in SMEs from agriculture. In *Proceedings: Actual Tasks on Agricultural Engineering-Zagreb*, vol.47, 479-485.
- Crisan, G.C., Tucu, D., Boboescu, R. (2017). Improvement of safe & healthy work systems in agricultural SME's. In *Proceedings: Actual Tasks on Agricultural Engineering-Zagreb*, vol.45, 657-663.
- Darabont, D.C., Bejinariu, C., Ionita I., Bernevig-Sava M.A., Baciu C., Baciu E.R. (2018). Considerations on improving occupational health and safety performance in companies using ISO 45001 Standard. *Environmental Engineering and Management Journal*, Vol.17, No. 11, 2711-2718.
- Esteban, L., Jesús, A. (2021). Territorial efficiency: Analysis of the role of public work safety controls. *Safety Sci.* 134, <https://doi.org/10.1016/j.ssci.2020.105074>, accessed September 2022.
- Kari, A.H., Gro, F. (2018). Making occupational health and safety training relevant for farmers: Evaluation of an introductory course in occupational health and safety in Norway. *Safety Sci.* 109, 368-376.
- Hasle, P., Kvorning, L.V., Rasmussen, C.D., Smith, L.H., Flyvholm, M.-A. (2012). A model for design of tailored working environment intervention programmes for small enterprises. *Saf. Health Work* 3, 181–191.
- Sinclair, R.C., Cunningham, T.R., Schulte, P.A. (2013). A model for occupational safety and health intervention diffusion to small businesses. *Am. J. Ind. Med.* 56, 1442–1451.
- Bodescu, D., Robu, A.-D., Jiăreanu, A.F., Puiu, I., Gafencu, A.M., Lipsa, F.D. (2022). Work Satisfaction in the Food Industry—A Premise for Economic Performance. In: *Agriculture*. 12, 1015. <https://doi.org/10.3390/agriculture12071015>.
- Tucu, A., Purcarea, A.A., Crisan, G.C., Vasilica, A., Tucu, D. (2021). Quality evaluation of occupational health & safety (OHS) risk management systems from agriculture. In *Proceedings: Actual Tasks on Agricultural Engineering-Zagreb*, vol.48, 527-534.

- \* \* \*, ESENER. (2022). Third European Survey of Enterprises on New and Emerging Risks (ESENER 2019): Overview Report, How European workplaces manage safety and health. European Agency for Safety and Health at Work, Luxembourg: Publications Office of the European Union, ISSN 1831-9343, 7-8.
- \* \* \*, European Commission. (2014). EU Strategic Framework on Health and Safety at Work 2014–2020. Communication from the Commission to the European Parliament, the Council, the European Economic and Social Committee and the Committee of the Regions, COM, 332.





## SOME PARTICULARITIES OF TELEWORK ACTIVITIES PRACTICED IN AGRICULTURE

Ramona DZITAC<sup>1</sup>, Ileana MOGOȘANU<sup>1</sup>, Simina-Ștefania MARIȘ<sup>2</sup>,  
Gabriela-Victoria MNERIE<sup>3\*</sup>, Mihaela POPUȚA<sup>4</sup>

\*E-mail of corresponding author: gabi.mnerie@gmail.com

<sup>1</sup> Politehnica University of Timisoara, Mechanical Engineering faculty, Mihai Viteazu, 1,  
300222, Timisoara, Romania

<sup>2</sup> IOAN SLAVICI University, Dr. Aurel Paunescu Podeanu, 144, 300587, Timisoara, Romania

<sup>3</sup> National R&D Institute for Welding and Material Testing - ISIM Timișoara, 30, Mihai Viteazu Blv.,  
300222 Timișoara, Romania

<sup>4</sup> West University of Timișoara, Vasile Pârvan, 4, 300223, Timișoara, Romania

### ABSTRACT

*In last years, the technological progress regarding the modernization of agriculture is remarkable. Along with the increasingly extensive use of precision agriculture, companies with basic agricultural activities have increasingly chosen the use of telework activities for part of employees. This way of organizing the work practiced in agricultural farms and other organizations from agriculture brings into focus several new elements of engineering and management. They are corroborated with special regulations and procedures, both in the employer-employee relationship, and in relations between specialized state institutions for guidance and control with companies that use telework. The paper includes the presentation of a study on the technical and managerial way of practicing telework activities in agricultural specific units in Timis County (Romania). Some results of the study are highlighted that can bring legislative additions, regarding the specific activity of guidance and control, both regarding new labor relations and those related to safety and health at work.*

**Keywords:** *agricultural organizations, teleworking, control management, labor relations, and health at work.*

### INTRODUCTION

#### ***About teleworking***

The growing performance in agriculture could be achieved due to continuous modernization, along with technological progress in other fields. So, the telework regime was

able to be more and more present at the level of agricultural units. In general, telework has entered the concerns of several researchers, being characterized in multiple ways. The need to telecommute has been expressed as far back as seven decades ago, with revolutionary advances in telecommunications and computing technologies that have enabled companies to organize work away from the traditional office through alternative arrangements for work. (Loia, F. and Adinolfi, P., 2021). In the scientific literature, the term "teleworking" was used for the first time by J.M. Nilles, first addressing the term "telecommuting", defined as a network of computing and telecommunications components that allow employees of large organizations to work in offices closer to their homes rather than commuting long distances to an office central. Nilles also specifies some requirements for the development of terminal computer capability to be more versatile, reliable and/or lower cost, developments that will lead to a standardization of some aspects of teleprocessing technologies. (Nilles, 1975). The same American author will return with the results of some research on the managerial possibilities of remote work management, also talking about the virtual workforce (Nilles, 1998).

These technological changes have given more meaning to the concept of telework, which has been the subject of significant attention in managerial, organizational and sustainability research. With the rapid development of IT hardware and software, remote work has become widespread and increasingly perceived as the "next workplace revolution". The new generation of modems, ISDN (Integrated Services Digital Network) systems, advanced and sophisticated personal computers and laptops and similar technologies, together with a significant reduction in the cost of equipment and especially the decrease in the cost of telecommunications, certainly marked the beginning of the telecommuting era. After the '90s, telework was defined as an "alternative way of working" or as "flexible work arrangements". Based on these considerations, telework has attracted the global attention of various categories of stakeholders, especially employees and employers, from several fields of activity. (Loia, F. and Adinolfi, P., 2021).

Extensive desires to change the frequency of remote work emerged, rather than exploring the motivations behind these desires. In addition, it has been overlooked how factors relating to the contextual conditions in which telework is performed (eg, job design, social and physical homework environment) might affect telework propensities. A more nuanced approach to this way of working is needed, considering factors relating to the contextual conditions in which remote work is carried out (e.g., job design, social and physical environment of homework (Weber, C., et al., 2022).

The current knowledge-based information society demonstrates the capability of the most modern and spectacular information and communication technologies adaptable to teleworking processes. We must not forget the disadvantages that may arise, even great dangers regarding the individual, family life and/or society. In Romania, studies were carried out that proved that during the pandemic, in some companies that used telework intensively, employee productivity increased for 30% of the responding companies, while 44% believe it remains at the same level. There is currently an undoubted tendency to ensure the continuity of this trend and perhaps its acceleration, with the provision of an increasingly efficient technological infrastructure, in compliance with an appropriate legal framework adopted. The European Union has launched a strategy on the development of digitization based on a program of appropriate investments to lead to a better performance in a relatively short time. (Stoica, M., et al., 2021), (Vargas, et al., 2022).

Telework can only be carried out with the will of the employee, willing to carry out a professional activity outside the main workplace, thanks to information and communication technologies (Tissandier, P. and Mariani-Rousset, S., 2021), (Solomon, 2021).

Teleworking, according to the changes made by GEO 36/2021 regarding the amendment of law 81/2018, is: the form of work organization through which the employee, regularly and voluntarily, fulfills the specific duties of the function, occupation, or job that he holds in a place other than the workplace organized by the employer, using information and communication technology. The teleworker is any employee who carries out an activity under the conditions presented above. From a legal point of view, telework should not be confused with homework, although it is still a form of work from home, and the most used term when it comes to telework is remote work. Telework is based on the voluntary agreement of the parties, by concluding an individual employment contract, or, if applicable, an addendum to the individual employment contract. (The law no.81, 2018, Ro.), (Dita, G., 2021).

The benefits of teleworking activities are multiple. They have been featured in many scientific papers with different research approaches. For example, the beneficial effects of teleworking on the environment were highlighted. (Fuhr J., and Pociask, S., 2011), favorable assessments being also from the Romanian business environment (Grigorescu, A. and Mocanu A., 2020)

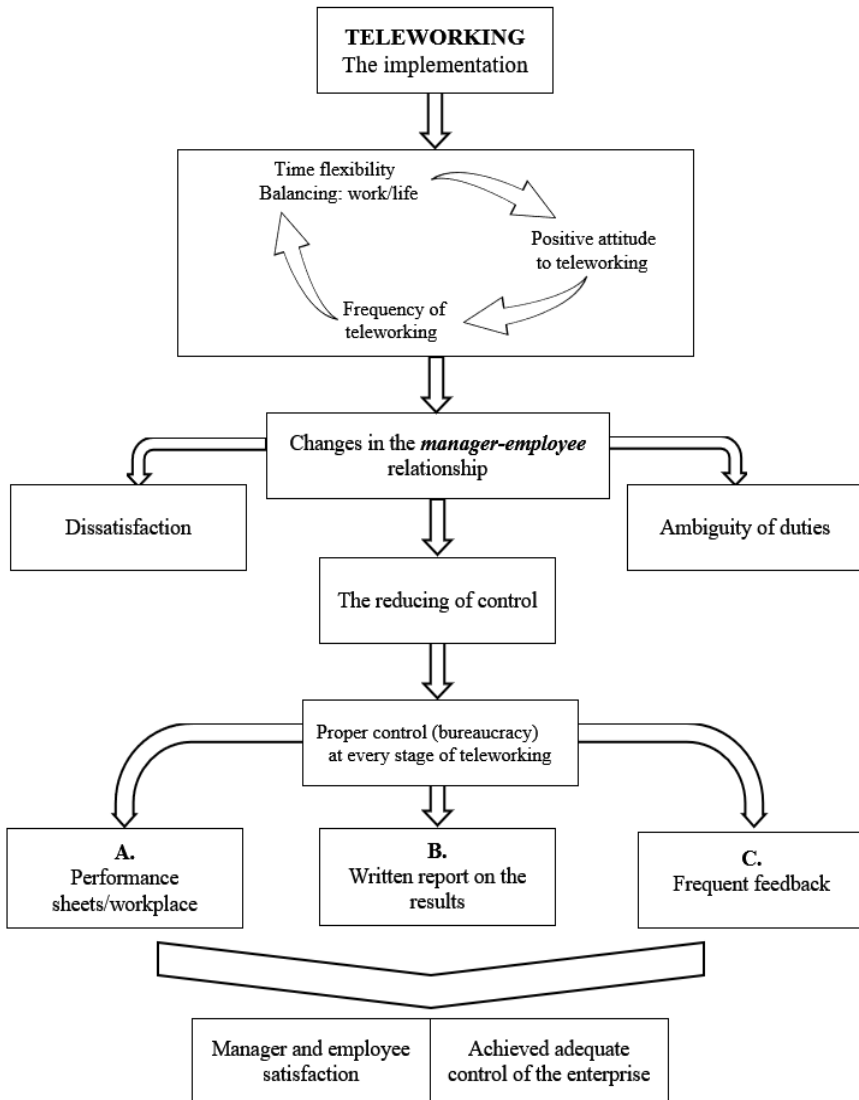
### ***Opportunities of teleworking in agriculture***

The modernization of the technologies currently applied in agriculture opened the way for the practice of the telework system. In the last 25-30 years, the mentalities of those who work the land have also changed (Krakowiak-Bal, A., 2009). An opportunity for teleworking has arisen through the practice by large farmers of the precision agriculture (AP) system, which can be appreciated as a farm approach, identifying the important parameters where the yield of agricultural production is limited by variable parameters and determines the integral spatial variability. In this sense, data management systems (GIS), procedures for ensuring soil maintenance through variable rate fertilization, diagnosing the state of plants by monitoring the chlorophyll level, for certain maintenance works and product collection, the use of collaborative robots have already been implemented, as well as other advanced mechatronic systems (Mnerie D., 2020). For example, many conventional irrigation systems have been improved by implementing advanced technologies based on wireless sensor networks that help reduce crop losses, prevent over-watering of crops, and help increase actual crop yield. The surveillance of the automated system of sensors intended to monitor the crop field with interventions, after the irrigation actions are needed, make it possible to keep the link on the wireless system of transmitting the data recorded in the field to the remote coordinator (Jyotshna Kumari, J. and Kumar, S., 2017). In this way, the coordinator can exercise his duties remotely, even possibly through a mobile application.

Another efficient precision agriculture system may involve the creation of a function assigned to a terminal node, which would periodically record soil moisture content, air humidity and temperature, light intensity, through a self-organizing network. The collected information is transmitted to the wireless gateway using modes such as LAN or WAN. These systems apply cluster topologies and hierarchical routing protocols for this purpose. Each sensing node is divided into several clusters, and each cluster is analogous to a kind of immovable self-organizing network. The nodes are then shared and the cluster head nodes. The work of common nodes is to accumulate facts that are sent to the main nodes of the

cluster. Received data is stored in the memory unit. Then an expert decision support system analyzes and processes this data. This network node can be large-scale, using a high-density deployment method to monitor coverage area and connectivity (Shekarchizadeh, A., et al 2019). All activity in the node can be monitored remotely by the specialist employee.

The model adopted for the implementation of telework in a company was considered after the model offered by Shekarchizadeh, A., et al., 2019, shown in figure 1.



**Figure 1** The model adopted for the implementation of telework in a company. (Shekarchizadeh, A., et al 2019)

## MATERIALS AND METHODS

The academic and research environment in Timișoara has developed a permanent collaboration with public institutions in the monitoring of telework activities in agricultural companies in Timiș county, out of the desire to find optimal institutional ways of guidance and control. In this sense, a tradition of collaboration was formed between the Territorial Labor Inspectorate of Timis and the Polyethnic University of Timisoara. The Timis Territorial Labor Inspectorate (ITM) is a public institution subordinate to the National Labor Inspectorate, created with the aim of controlling the uniform application of laws and other normative acts that regulate the field of work, labor relations, safety, and health at work. for all legal entities and natural persons from the public, mixed, private sector, and other categories of employers, under the terms of Law no. 108/1999. (Timiș Labor Inspectorate, 2022)

Starting from these attributions, in the period 2019-2022, including the atypical period due to the COVID-19 pandemic, this study was carried out, having as its main objective the analysis of the evolution of telework activities, in the agricultural economic environment, as well as the organizational forms which should be implemented by state institutions, to optimize cooperation for the efficiency of this modern way of working.

For this study, data was collected from 26 agricultural companies that reported teleworking to ITM during this time frame. Monthly data were requested on:

- The number of employment contracts and the special additional documents for teleworking;
- The technical (IT) way of ensuring the employee-employer relationship during this period;
- Qualitative assessments regarding the performances obtained in relation to the working conditions at the office;
- Share of gainful teleworking activities, divided into two categories: directly gainful vs. administration-management;
- The number of reports and complaints from employees;
- The number of warnings and penalties applied by ITM for non-compliance with the legal framework, regarding telework activities.

## RESULTS AND DISCUSSION

The results were systematized and entered in table 1. Analyzing the data presented in the table, several aspects regarding the research objectives can be distinguished. The data show that, for the time being, no employment contracts have been registered with full telework activity, but only with the part-time telework option, with greater stability due by the agricultural work season. Percentages between 40 - 80% of the normal monthly working time were recorded.

The halving of the percentage of employee complaints in the last 4 years is proof of their increased satisfaction with the way teleworking is organized and carried out.

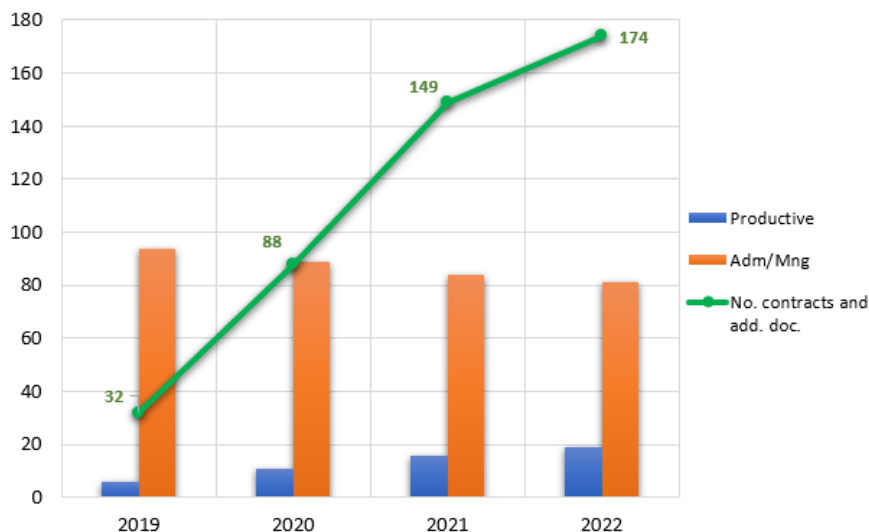
Correlating the number of contracts and additional documents with the typological weight of the activities, (figure 2), an increase in the use of telework for directly profitable activities

can be observed, most of them directly related to the implementation of specific IT systems, in precision agriculture.

**Table 1** Data extracted for comparative analysis of teleworking

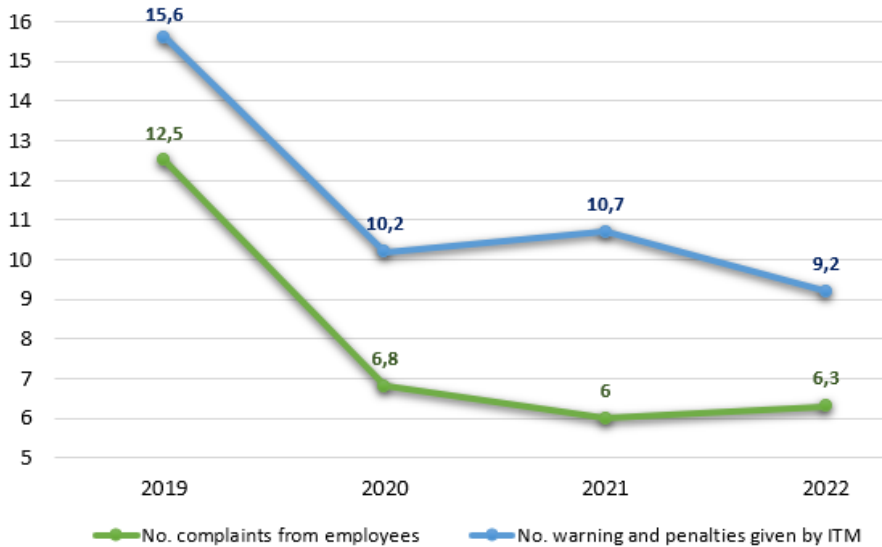
Characteristic		2019	2020	2021	2022
No. contracts and add. doc.		32	88	149	174
IT used	Own platform	-	2	6	11
	Public network	26	24	20	15
The share of activities, [%]	Productive	6	11	16	19
	Adm/Mng	94	89	84	81
Qualitative assessments and economic performance, [%]		+8	+19*	+38*	+18
No. complaints from employees	No.	4	6	9	11
	[%]	12.5	6.8	6.0	6.3
No. warning and penalties given by ITM	No.	5	9	16	16
	[%]	15.6	10.2	10.7	9.2

\*The evaluation was carried out in pandemic conditions, when telework performances were evaluated relative to the alternative of interrupting the respective activities.



**Figure 2** Graphical correlation of the numerical evolution of telework contracts with the type of workload

As can be seen in the figure 3, the decreasing trends in the number of warnings and sanctions given by ITM are also due to the increase of the training level carried out by specialist inspectors towards employers.



**Figure 3** Graphical correlation of the evolution of employee dissatisfaction with the conditions of teleworking with the number of sanctions applied by the ITM

Making a more detailed analysis of the content of employee complaints and the reasons for granting penalties by the control bodies, the existence of possible considerations related to certain disadvantages and risks of telework were also confirmed. Yet, there was, however, a small number of employees who complained of the apparition of a sense of isolation and a strong sense of invasion of privacy by those who follow employees using electronic monitoring, aspects already reported in the specialized literature (Jahagirdar, R., and Bankar, S., 2020). Also, there were (still a small number) of employees who recognized the emergence of states of anxiety, or insecurity, even fear, for the possibility of losing their job. These aspects confirm already the results of previous research, which highlighted a need to approach the teleworking activity, with a greater target towards the "wellbeing" aspect of the employees. (Kossek, E., et al., 2009), aspect also developed by another research from Romania (Catană SA, et al. 2022).

The results of the research announce a prospect of expanding the implementation of telework in modern agricultural units as well.

## CONCLUSIONS

The teleworking activity, although present with a rather small weight in the agriculture of the Timiș county (for now, under 10%), requires increased attention, both from the employers

and from the public institutions with attributions in the guidance and control of work activities.

The characteristic aspects identified in this research were the subject of some debates during the training sessions of specialized ITM inspectors. The need to resume such research is noted, not only from the perspective of the evolution and perspectives of telework in the agriculture of Timiș County in Romania, but with an address to the entire labor market, everywhere.

The changes brought by the implementation of telework determine important changes in managerial programs. The research brings to attention the particularities of profitable activities in agriculture, which require an optimized management to increase the efficiency of this practice.

It is necessary to adopt new ways of monitoring telework, based on both organizational aspects and specific technical solutions. Therefore, it is necessary to avoid the misuse of organizational resources and related expenses, seeking to preserve the confidentiality of intellectual property and secrets involving the workplace, avoiding the full assumption of legal liability because of improper employee behavior, seeking managerial forms based on remote cooperation as well, aiming to increase employee performance, with expected profitability for employers.

From the actual analysis of the results of this research, it can be concluded that the telework activity carried out in agriculture brings many benefits to both the employer and multiple advantages to the employees. But the negative consequences that can occur, especially to the disadvantage of employees, should not be ignored.

The research carried out on some particularities of the practice of telework in agriculture, once again demonstrates the maintenance of a pace of progress in the field, in conjunction with the general progress of science and technologies.

## REFERENCES

- Catană Ș.A., Toma S.G., Imbrisca C., Burcea M., (2022) Teleworking Impact on Wellbeing and Productivity: A Cluster Analysis of the Romanian Graduate Employees. *Front. Psychol.* 13:856196. doi: 10.3389/fpsyg.2022.856196.
- Dita, G., (2021), Teleworking or work from home, Publisher Rentron &Straton, ISBN 978-606-47-0570-9.
- Fuhr J., Pociask, S., (2011), "Broadband and Telecommuting: Helping the U.S. Environment and the Economy", *Low Carbon Economy*, Vol. 2 No. 1, 2011, pp. 41-47. doi: 10.4236/lce.2011.21007;
- Grigorescu A., Mocanu A., (2020), Teleworking Perspectives for Romanian SMEs after the COVID-19 Pandemic.
- Jahagirdar, R., & Bankar, S., (2020). Employees Perception of Workplace Monitoring and Surveillance. *PEOPLE: International Journal of Social Sciences*, 6(1), 474-486.
- Jyotshna Kumari J., Kumar S., (2017), Precision Agriculture Based on Wireless Sensor Network, *International Journal of Latest Technology in Engineering, Management & Applied Science (IJLTEMAS)*, Volume VI, Issue III, March 2017.
- Kossek E., et al., (2009). "Good teleworking": Under what conditions does teleworking enhance employees' well-being? In *Technology and Psychological Well-being*, Yair Amichai-Hamburger, (Editor), Cambridge: Cambridge University Press, pp. 148-173.



- Krakowiak-Bal A., (2009), Multidimensional comparative analysis of other gainful activities, of agricultural holdings in EU countries, Commission of Technical Rural Infrastructure, Polish Academy of Sciences, Cracow Branch. Nr 7/2009, 129-137.
- Law no. 81 of 30.03.2018, regarding the regulation of telework activity, issued by the Parliament of Romania, with legislative updates including from 2022.
- Loia F., Adinolfi P., (2021), Teleworking as an Eco-Innovation for Sustainable Development: Assessing Collective Perceptions during COVID-19. *Sustainability* 2021, 13, 4823. <https://doi.org/10.3390/su13094823>.
- Mnerie D., (2020), Modern agro-industrial equipment, Course support, Politehnica University Timisoara, Romania
- Nilles J. (1975), Telecommunications and Organizational Decentralization. *Ieee Trans. Commun.* **1975**, 23, 1142–1147.
- Nilles J.M., (1998), “Managing Telework: Options for Managing the Virtual Workforce,” John Wiley & Sons, 1998.
- Shekarchizadeh A., Ghasemi L., Tadi M.J., Soltani A., Nili M., (2019), Teleworking and Its Impact on institutional Control in Organizations, *Saons Humanika Journal*.
- Solomon O., (2021), Teleworking between option and necessity: analytical reflections, <https://doi.org/10.53783/18572294.21.185.07>, CZU:51:004.9.
- Stoica M., Ghilic-Micu B., Mircea M., (2021), The telework paradigm in the IoE ecosystem – a model for the teleworker residence choice in context of digital economy and society, *Economic Computation and Economic Cybernetics Studies and Research*, Issue 3/2021; Vol. 55.
- Timiș Labor Inspectorate, (2022), <https://www.inspectiamuncii.ro/web/itm-timis/>, last accessing in October 2022
- Tissandier P., Mariani-Rousset S., (2021), The benefits of teleworking, *Revue francophone sur la sante et les territoires*, URL: <http://journals.openedition.org/rfst/831>; DOI: <https://doi.org/10.4000/rfst.831>
- Vargas L., O., Rodríguez Contreras R., Sanz de Miguel P., Voss E., Benning C., (2022), Telework in the EU: Regulatory frameworks and recent updates, Research report, Eurofound, Wilke Maack GmbH).
- Weber C., Golding S.E., Yarker J., Lewis R., Ratcliffe E., Munir F., Whele T.P., Häne E., Windlinger L., (2022), Future Teleworking Inclinations Post-COVID-19: Examining the Role of Teleworking Conditions and Perceived Productivity, Aikaterini Grimani, University of Warwick, *Frontiers in Psychology Journal*, United Kingdom.

---

---



## ANALYSIS OF REGISTERED TRACTORS IN SLOVENIA IN THE YEAR 2021

Tomaž POJE

E-mail: tomaz.poje@kis.si

*Agricultural institute of Slovenia, Department of Agricultural Engineering and Energetics  
Hacquetova ulica 17, SI – 1000 Ljubljana, Slovenia*

### ABSTRACT

*Analysis was performed on the data of registered tractors in Slovenia in the year 2021. At the end of the year, there were 116,707 registered tractors. 1,362 of them were new tractors. 1.4 % of buyers of new tractors received a financial subvention from the state. In 2021, the average power of a new tractor in Slovenia was 63.3 kW. Among the owners of new tractors were 340 legal entities and 1022 individuals. 92.6 % of individuals are men and 7.4 % are female tractor owners. Most owners (28.8 %) were aged between 50 and 60 years. The leading seller is New Holland, with 16.2 % share.*

**Keywords:** *Slovenia, tractor, number of tractors, average power, registration, owners*

### INTRODUCTION

According to data from the Statistical Office of the Republic of Slovenia (SURS, 2017), there were 69,902 agricultural holdings in Slovenia on June 1, 2016. Agricultural farms have 418,684 conditional head of livestock (UG), which is 3% more than in 2013. Since 2013, the number of agricultural farms has decreased by 3.4%. Each farm cultivates an average of 6.9 hectares of agricultural land (0.3 ha more than in 2013) and they raise 7.5 conditional heads.

According to the Census of Agriculture from 2010 (SURS, 2012), there were 101,756 tractors in Slovenia, while for 2013, SURS lists 106,696 tractors. In addition to these two-axle tractors in 2013, SURS lists 21,292 single-axle tractors. According to SURS data, the average age of registered tractors is more than 21 years. A total of 83,291 tractors registered in 2014 were older than 12 years. Tractors and agricultural machinery were not included in the Census of Agriculture 2020. Poje studies the tractor fleet in Slovenia regarding the number of tractors, their power, age, etc. In Slovenia, 1,103 new tractors were registered in 2016, but not co-financed. Average power of new tractors in 2016 is 61.5 kW. The leading seller is New Holland, with 14.5% share. At the end of 2016 the number of all registered tractors was 108,914 (Poje, 2018). At the end of 2013, there were 100,965 registered tractors in Slovenia.

Among the owners of new tractors were 650 legal entities and 875 individuals. 91.5% of individuals are men and 8.5% are female tractor owners. Most owners (29.9%) were aged between 50 and 60 years. Most manufacturers are using the possibility of the transitional period about the prescribed levels of pollutant emissions for new tractors (Poje, 2015). The same parameters of registered tractors were also analysed in older publications (Poje 2012; Poje 2010).

Nearly 230,000 “tractors” were registered across Europe in the full year 2021, according to numbers sourced from national authorities. Of these registrations, just under 30% were of vehicles of 37kW (50 hp) and under and the remainder were 38kW and above. CEMA considers that just under 180,000 of these vehicles are agricultural tractors. The rest are made up of a variety of vehicles which are sometimes classified as tractors, which includes quad bikes, side-by-sides, telehandlers or other equipment. The two biggest agricultural tractor markets in Europe remain France and Germany, with those two countries accounting for almost four agricultural tractors out of every ten registered in Europe. In Germany, 34,472 agricultural tractors were newly registered in 2021. This corresponds to an increase of 8.6%, compared to the previous year. Almost three quarters of the registered vehicles were tractors with a power output of more than 50 hp. In France, 36,053 tractors were registered for the first time (CEMA, 2022).

According to the data of the Croatian Vehicle Center (CVH, 2022), based on a technical inspection, 133,564 tractors were registered in Croatia in 2021, with 90.80% being over 10 years old. The average age of registered tractors in Croatia is 31.82 years.

The aim of this work is to analyse the development trends of the tractor fleet in Slovenia based on data on registered tractors.

## **MATERIALS AND METHODS**

Slovenia has two important tractor databases. The first is at the Statistical Office of the Republic of Slovenia (SURs), which, until 2010, analysed agricultural machinery, i.e. tractors, every time within the Census of Agriculture. The second is the database of Ministry of Public Administration on registered vehicles (tractors). Since 2014, this database has been on the new NIO portal, which is a website, intended for the publication of open data of the public sector in Slovenia. This portal also contains information on newly registered vehicles in Slovenia. The Ministry of Infrastructure and Spatial Planning and the Ministry of Internal Affairs are responsible for this data.

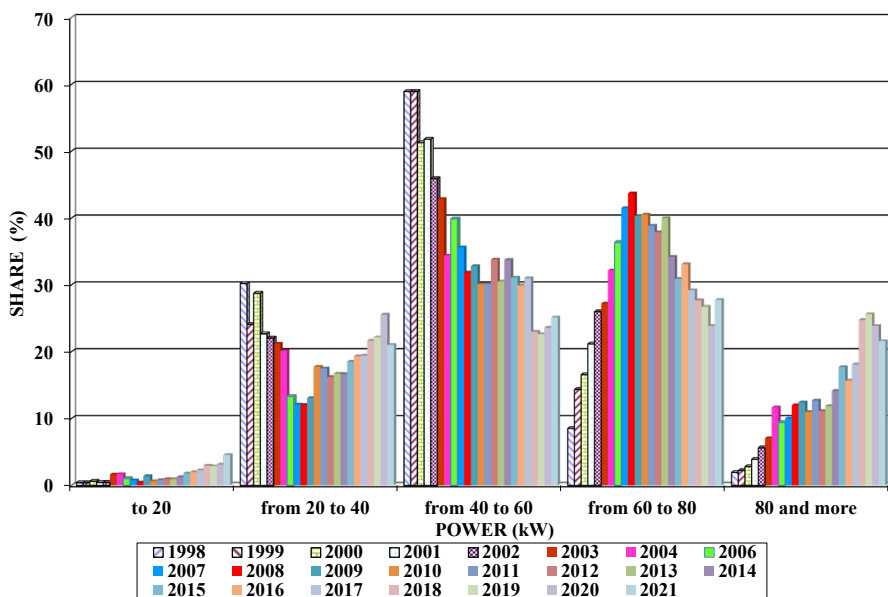
This paper analyses the new, registered tractors in Slovenia in 2021, i.e. the development trends of the tractor fleet in Slovenia. Appropriate statistical analyses (descriptive statistics) were used for data processing.

## **RESULTS AND DISCUSSION**

In 2021, 1,362 new tractors were registered in Slovenia. The average power of a new tractor was 63.3 kW. If we classify the new tractors into categories according to power, most of them fall in the power category of 60 to 80 kW, i.e. more than 27% of all tractors. The category of tractors with power between 40 and 60 kW follows with 25.1%. The categories of tractors from 20 to 40 kW and above 80 kW have 20.9% and 21.6% respectively. The

lowest power category of tractors (up to 20 kW) represents a very small share or slightly less than 4.6% of tractors sold.

Graph 1 shows new registered tractors by power category since 1998. The graph shows an increase in tractor category with engine power above 80 kW. The share of new tractors in the power category between 40 kW and 60 kW was decreasing during all analysed years. The share of new tractors in the power category between 60 kW and 80 kW was increasing until 2008 and decreasing after that. At the beginning of the studied period the share of new tractors in the power category between 20 kW and 40 kW was decreasing, from 2008 the share is increasing. The percentage of new tractors in Slovenia with engine power below 20 kW is small and relatively constant. In general, we can say that farmers do not buy tractors with too much power, because consolidation (increase in agricultural land) of agricultural property in Slovenia is growing slowly - the average size is 6.9 ha.



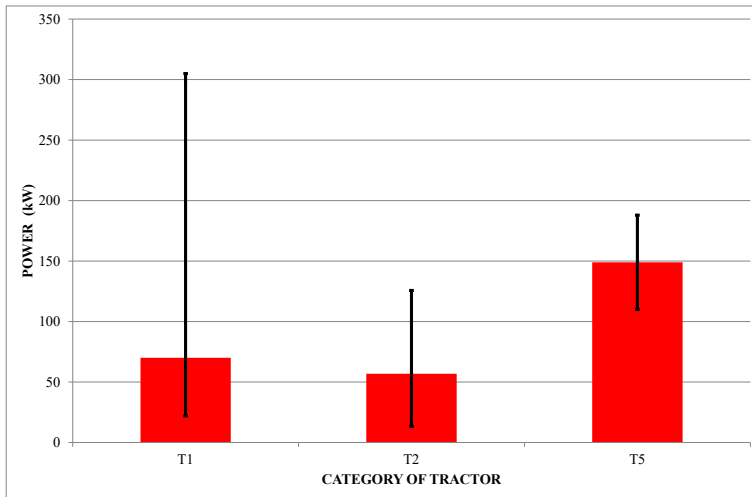
**Graph 1** New tractors registered in Slovenia between year 1998 and 2021 with regard to the category of power

From the data of registered tractors, the average power of tractors registered in a particular year was obtained. Table 1 shows how the average strength increased over a period of 10 years. For tractors produced and registered in 1952, the average power was 19.6 kW. In 2021, the average power of new tractors in Slovenia was slightly more than 63 kW.

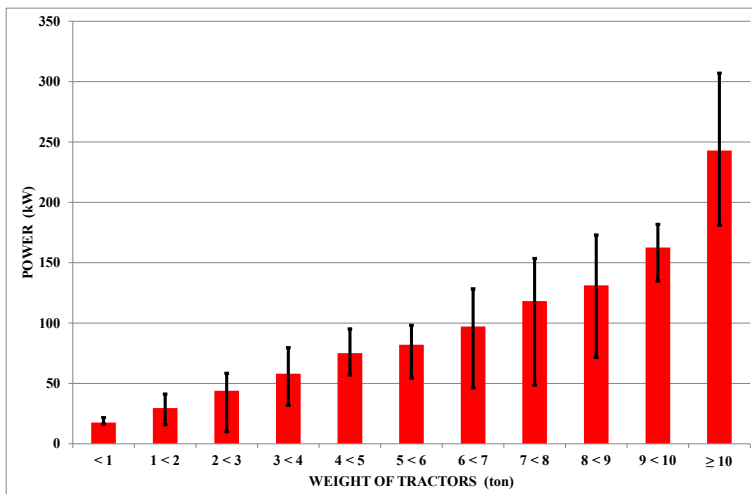
**Table 1** Average power of registered tractors between years 1952 and 2021

Year	1952	1962	1972	1982	1992	2002	2012	2021
Average power (kW)	19.6	21.7	24.9	34.4	40.2	53.5	60.2	63.3

Depending on the homologation requirements, we have different types of wheeled tractors in Slovenia. The data from graph 2 show us that tractors of categories T1, T2 and T5 were registered in 2021. The graph shows the average tractor power in each category of tractors (T1, T2 and T5) and the minimum and maximum tractor power in these individual categories (handles). Category T5 means wheeled tractors that go over 40 km/h. The average power in this category is 149 kW, and the maximum is 188 kW.



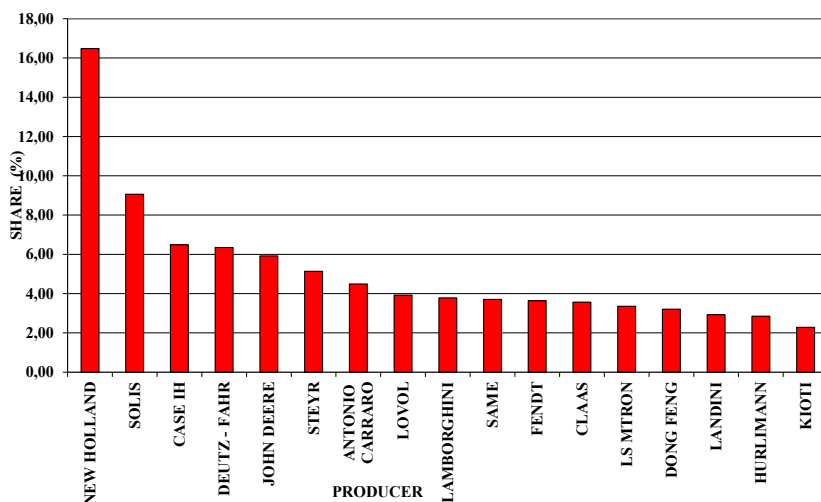
**Graph 2** Average power, minimum power and maximum power of tractors with regard to their category



**Graph 3** Average power, minimum power and maximum power of tractors with regard to their weight

Tractors are getting heavier and so are their attachments. In 1952, tractors weighed an average of 1,640 kg, and in 2021, they weighed 3,713 kg. The heaviest tractor registered in 2021 weighed as much as 16,900 kg. Increasingly larger and heavier tractors and attachments also result in a greater negative impact on the soil. With the passage of tractors and attachments, there is unwanted soil pressure and thus increased soil compaction under the wheel tracks. Graph 3 presents power of tractors with regard to their weight.

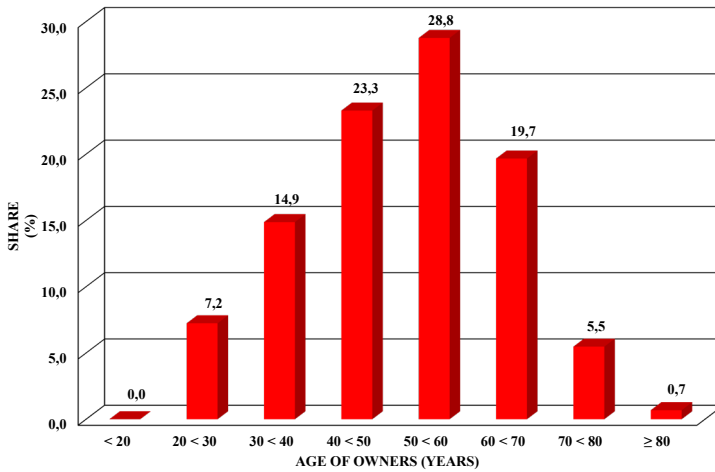
The analysis of new tractors in 2021 shows that New Holland is first in tractor sales with 16.48%. New Holland has been the leader in tractor sales in Slovenia for many years. In 2021, Solis is second in sales, and Case IH is third. Graph 4 shows the first 17 manufacturers by representation (that is, those manufacturers with sales of more than 2%). All in all, tractors from 40 different manufacturers were sold in Slovenia in 2021. At the end of the ranking according to sales are Carraro, JCB and Reform with one tractor each.



**Graph 4** Percentage of new tractors in the year 2021 with regard to producer

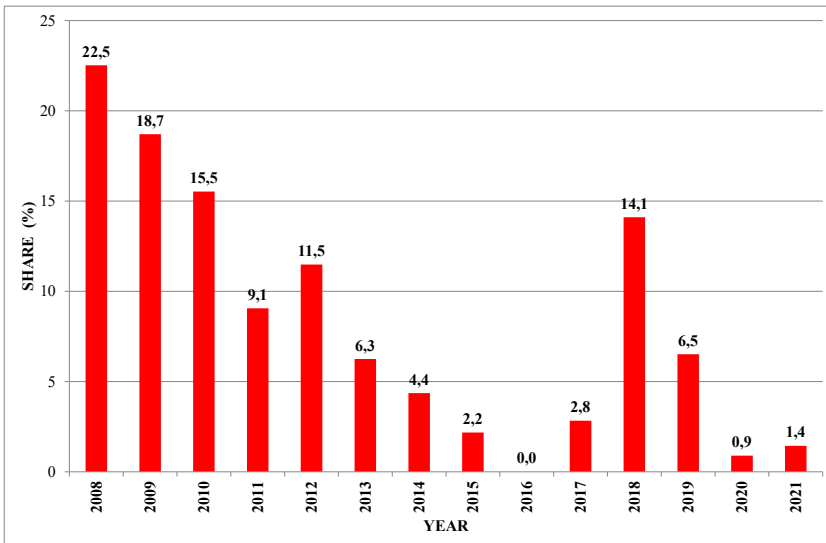
The analysis of ownership of new tractors shows that 75.04% are individuals and 24.96% are legal entities. Among individuals, 92.56% are men and 7.44% are women. The number of legal entities among tractor buyers is significant. From the data for the refund of excise duty for fuel used in agriculture, it is recorded that there are about 90 legal entities (companies) in Slovenia engaged in agriculture. The trend in Slovenia is for family farms to form their own companies due to a number of benefits or requirements in business (various subsidies, tax breaks, etc.).

In 2021, as in the year before, the majority of buyers - owners of new tractors (28.8% share) are in the age group between 50 and 60 years old (graph 5). This is followed by the group of owners between the ages of 40 and 50 with a share of 23.3%. There are no owners of new tractors younger than 20 years old. 0.7% of customers are over 80 years old, the oldest is even 86 years old.



**Graph 5** Percentage of owners of new tractors with regard to their age

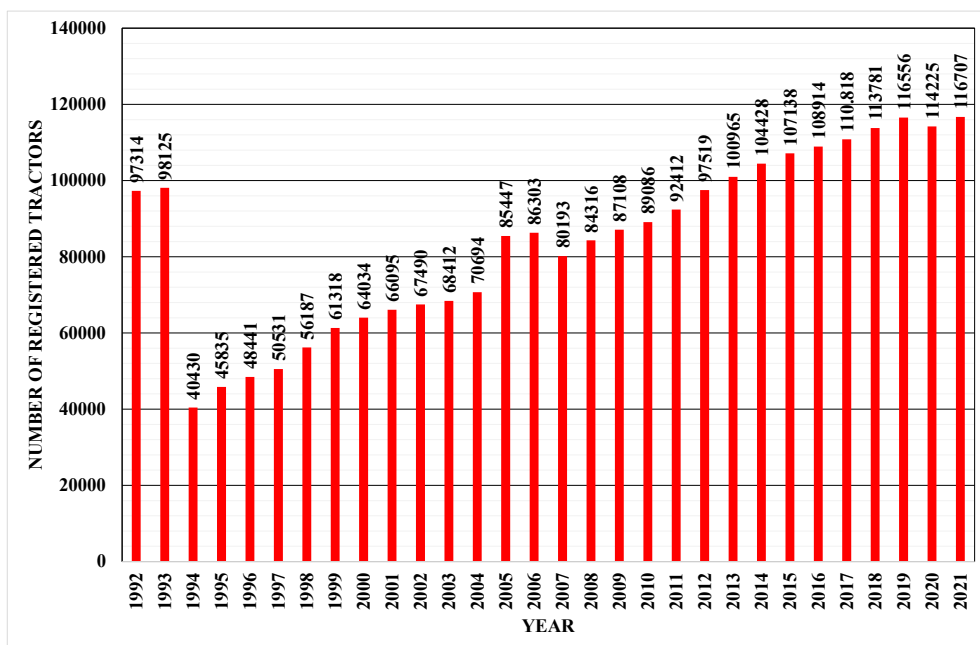
The Ministry of Agriculture co-financed the purchase of new tractors as part of the Agricultural Development Measure. The share of co-financed tractors for individual years is shown in graph 6. It can be seen that co-financing from 2008, when there were 22% of tractors, fell in 2016 to zero tractors. Since then, the share of co-financed tractors was even slightly higher in 2018, when it was 14.1%. In 2021, only 1.4% of new tractors were co-financed.



**Graph 6** Percentage of subsidized buying of new tractors



Graph 7 shows the number of registered tractors in Slovenia for the period from 1992 to 2021. In 1993, there were 98,125 registered tractors, while in the following year the number of registered tractors decreased to 40,430 tractors due to the transition to new Slovenian license plates, and then many owners no longer registered tractors. After that year, the number of registered tractors slowly increases. A large increase in registered tractors was recorded in 2005, when in Slovenia it was possible to register an old tractor without ownership information. At the end of 2021, there were 116,707 tractors registered. According to the Census of Agriculture from the summer of 2010, we had almost 101,756 tractors at that time (SURS 2012).



**Graph 7** Number of registered tractors in Slovenia with regard to the year

## CONCLUSIONS

At the end of 2021, 116,707 tractors were registered in Slovenia. 1,362 new tractors were registered this year. The state subsidized the purchase of 1.7% of new tractors. New tractors registered in 2021 have an average power of 63.3 kW. Analysis of new registration tractors by different power categories shows that new tractor buyers are purchasing more appropriate tractors for the size of their farms. The share of tractor category with engine power above 80 kW slowly increased in recent years. Among the owners of new tractors in 2021 were 340 legal entities and 1,022 individuals. Among individuals, the majority of buyers are men aged between 50 and 60.

## REFERENCES

- CEMA (2022), European tractor market hits new high despite supply chain challenges due to Covid-19; [https://www.cema-agri.org/images/publications/press\\_releases/2022-03-21-CEMA\\_Economic\\_Press\\_Release\\_Tractor\\_Registrations\\_2021.pdf](https://www.cema-agri.org/images/publications/press_releases/2022-03-21-CEMA_Economic_Press_Release_Tractor_Registrations_2021.pdf) (19.10.2022)
- CVH Center for Vehicles of Croatia / Centar za vozila Hrvatske (2022). Overview of vehicle age by vehicle type. [https://www.cvh.hr/media/4393/s01\\_\\_pregled\\_starosti\\_vozila\\_prema\\_vrstama\\_vozila\\_2021.pdf](https://www.cvh.hr/media/4393/s01__pregled_starosti_vozila_prema_vrstama_vozila_2021.pdf) (19.10.2022)
- Poje, T., Ježič, V., Cunder, T. (2006). Technical level of tractors on farms in Slovenia. *Acta agriculturae Slovenica*, let. 87, št. 2, str. 343-354.
- Poje, T. (2010). State of tractor pool in Slovenia. Proceedings of 38. International Symposium Actual Tasks on Agricultural Engineering, Opatija, February 22 - 26 2010, University of Zagreb, Faculty of Agriculture, Department of Agricultural Engineering, Zagreb, str. 67-74
- Poje, T. (2012). The development trends of the fleet of tractors in Slovenia. Proceedings of 40. International Symposium Actual Tasks on Agricultural Engineering, Opatija, February 21 - 24 2012, University of Zagreb, Faculty of Agriculture, Department of Agricultural Engineering, Zagreb, str. 23-29
- Poje, T. (2015). Situation in the field of agricultural tractors in Slovenia. Proceedings of 43. International Symposium Actual Tasks on Agricultural Engineering, Opatija, February 24 - 27 2015. University of Zagreb, Faculty of Agriculture, Department of Agricultural Engineering, str. 101-110
- Poje, T. (2018). Analyse of registered tractors in Slovenia in the year 2016. Proceedings of the "46. International Symposium Actual Tasks on Agricultural Engineering, Opatija, February 27 – March 1 2018, University of Zagreb, Faculty of Agriculture, Department of Agricultural Engineering, str. 627-633
- SURS Agricultural census 2010, Slovenija, 2010 – final data. (2012). First publication 29. March 2012, Statistical Office Republic of Slovenia – SURS [http://www.stat.si/novica\\_prikazi.aspx?id=4594](http://www.stat.si/novica_prikazi.aspx?id=4594) (19.10.2022)
- SURS Farm Structure Survey, Slovenia, 2016. (2017). Statistical Office Republic of Slovenia - SURS, E-publication 29.6.2017, <http://www.stat.si/StatWeb/News/Index/6742> (19.10.2022)



## PLASTIC WASTE BEHAVIOR DURING COMPACTION IN HORIZONTAL PRESS WITH CONTINUOUS FEEDING

Gheorghe VOICU<sup>1</sup>, Mircea-Bucur LAZEA<sup>1\*</sup>, Paula TUDOR<sup>2</sup>  
Gabriel-Alexandru CONSTANTIN<sup>1</sup>, Bianca-Stefania ZABAVA<sup>1</sup>

\*E-mail of corresponding author: mircealazea2005@yahoo.com

<sup>1</sup>University POLITEHNICA of Bucharest, Faculty of Biotechnical Systems Engineering

<sup>2</sup>University POLITEHNICA of Bucharest, Faculty of Entrepreneurship, Business Engineering and Management

### ABSTRACT

*The purpose of compacting recyclable waste is to reduce its volume for financial savings in storage and transport. Compaction can be done in stationary presses with vertical or horizontal flow with systems of various capacities. Recyclable waste has different behaviour in the compaction chamber of the presses, and this is influenced by several factors: type of waste, physical characteristics, humidity and others. The compaction process is energy consuming and this must be an important indicator that must be taken into account in the performance of a press. Determining the energy required for the deformation - compaction of waste in the pressing chamber is an objective of the research carried out on this type of compaction systems. The energy consumption for making waste bales can be an important and relevant indicator for industrial equipment. In the paper is presented the behaviour of PET bottle waste in baling presses with horizontal flow with discontinuous feeding. For this equipment and category of waste, was determined and confirmed through practical experiences some characteristics.*

**Keywords:** PET waste baling, compression force, displacement, energy consumed

### INTRODUCTION

Almost all specialized literature is, today, unanimous in the idea that baling is the most promising technique for relatively short-term storage of waste, either for incineration or for the recovery of raw materials for recycling (Oteng-Ababio et al., 2018; Cesaro and Belgiorno, 2020; Stenis et al., 2011; Robles-Mart et al., 2000; Ozbay and Durmusoglu, 2012; Tello Espinoza and Villagómez, 2012).

So, there is a global concern for finding social, techno-economic, environmentally friendly solutions that lead to a cleaner and greener environment. Integrated waste management includes, willy-nilly, the concepts of reduction, reuse, recycling, recovery and non-recyclable residues. Therefore, several steps need to be completed in this life cycle of municipal solid waste (MSW) namely: sorting, collecting, processing, marketing and then using recoverable materials, concepts defined as recycling and reuse. By properly treating and disposing of MSW, several benefits are brought, such as: improving environmental and health conditions, reducing the volume of waste, saving energy and raw material, generating income from the treatment of recyclable waste (Palma Lima et al., 2015).

The large volume of recovered waste, to be recycled, requires a significant reduction in its volume for storage and transport to recycling sites. In this sense, baling machines, with horizontal or vertical flow, are a direct necessity. Depending on the volume of recovered waste to be processed, recovery units can purchase waste baling machines of different capacities. Balers compress bulky waste into compact shapes, usually parallelepipeds, making them easier to handle, store and transport for recycling. A waste baler ensures a more convenient recycling flow with a positive effect on expenses (Osamwonyi et al., 2018).

The compaction system has a rigid metal structure at the front capable of mechanically moving the discontinuously fed waste and compacting it, the resistance force being given by the previously compacted bales and the shape of the compaction chamber which eventually narrows slightly towards the exit of the bales. The compaction system is operated by means of a double-acting hydraulic cylinder required to create a unidirectional force through a unidirectional stroke, hydraulic energy being converted into mechanical energy. The compaction system, including the hydraulic drive cylinder, is chosen according to the nature of the waste to be compacted and the volume of waste to be processed.

The baling-wrapping process has short-term beneficial effects on the microbiological activity of any gas leaks and other liquids remaining in the baled and wrapped waste, facilitating their handling and considerably reducing the impact on the environment, (Baldasano et al., 2003). So, there is also the concept of municipal (household) waste being stored in specific warehouses in the form of wrapped bales, even if they may undergo some degradation on the way from the producer to the place of deposit. The advantages would be in lower gas and liquid emissions, once the plastic-wrapped bales are stored in a warehouse where modern manufacturing and control methods are applied. But the paper's authors note that the long-term impact of various storage methods should be studied.

Furthermore, cylindrical bales from municipal solid waste were found to release about twice as many VOCs into the air (mainly toluene) as compared to parallelepiped bales ( $115 \pm 10 \mu\text{g}\cdot\text{m}^{-3}$ , respective  $64 \pm 8 \mu\text{g}\cdot\text{m}^{-3}$ , toluene), under the same conditions of storage and wrapping (wrap with 6 layers of LDPE of  $250 \mu\text{m}$  thickness) (Nammari et al., 2007).

MSW from cylindrical bales was also found to emit a higher concentration of esters than from rectangular bales, whereas emissions of aromatic compounds were dominant in wrapped rectangular bales containing the same types of MSW. The authors concluded that the mechanisms of waste degradation are different from cylindrical to rectangular bales. By doubling the number of wrapping layers, emissions from parallelepiped bales decreased, while emissions from cylindrical bales increased.

Observations also showed an increase in  $\text{CO}_2$  emissions for a period of 2 weeks, after which the concentration of  $\text{CO}_2$  decreased over a period of 32 weeks, in parallelepiped bales.

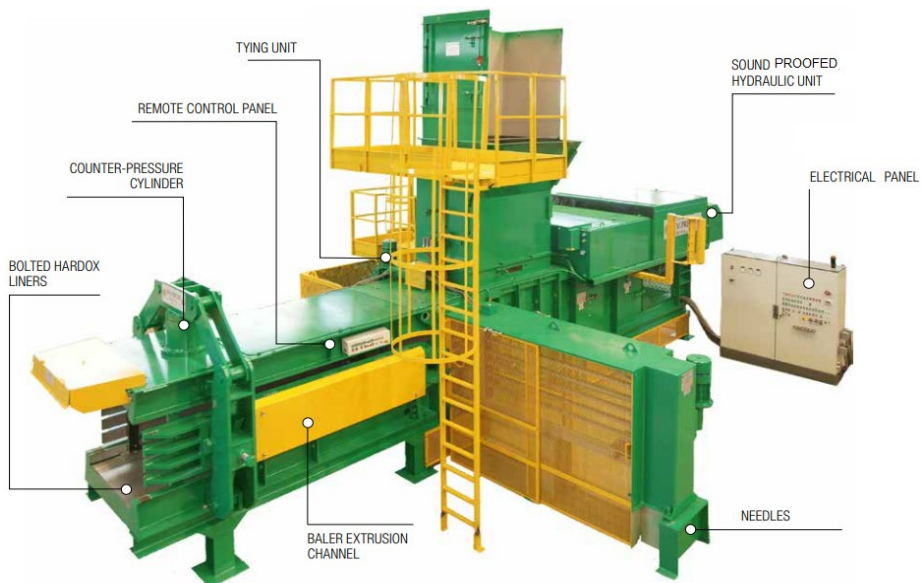
A similar trend was found for cylindrical bales, i.e. a daily increase in CO<sub>2</sub> emissions for a period of 8 weeks, then a gradual daily decrease in CO<sub>2</sub> concentrations for 25 weeks. This variation in CO<sub>2</sub> concentrations was associated with an equivalent variation in oxygen concentrations, leading to the conclusion that at the sampling point the bale was undergoing aerobic decomposition (Nammari et al., 2003 and 2007).

It should be remembered that the energy (calorific) characteristics of municipal solid waste in bales wrapped and stored over a longer period of time change depending on the type of waste in the mixture. So, Ozbay and Durmusoglu (2012, 2013) showed that their net calorific value (NCV) decreased over a 10-month storage period, mainly due to the food waste content of the MSW. However, plastics have an increasing trend in terms of NCV and total carbon (TC). Also, textile, wood and yard waste slightly increased the energy content of the bales during the mentioned storage period. If the food waste content increases inside the bales, then the total organic carbon (TOC) and the carbon/nitrogen ratio show a decreasing trend (Ozbay and Durmusoglu, 2012, 2013).

The paper presents the method of making bales from PET waste on presses with continuous horizontal flow and discontinuous feeding. The bale is formed from several loading batches, being kept pressed at the time of binding with metal wire, on the one hand by the press piston, and on the other hand by the previously formed bales remaining in the discharge channel of the press.

## MATERIALS AND METHODS

Horizontal balers for compacting and baling bulky, recyclable waste are designed to ensure all the necessary flow, from the supply of bulk waste to the discharge of bound bales.



**Figure 1** Overview of the horizontal baler from recyclable waste ([www.macpresse.com](http://www.macpresse.com))

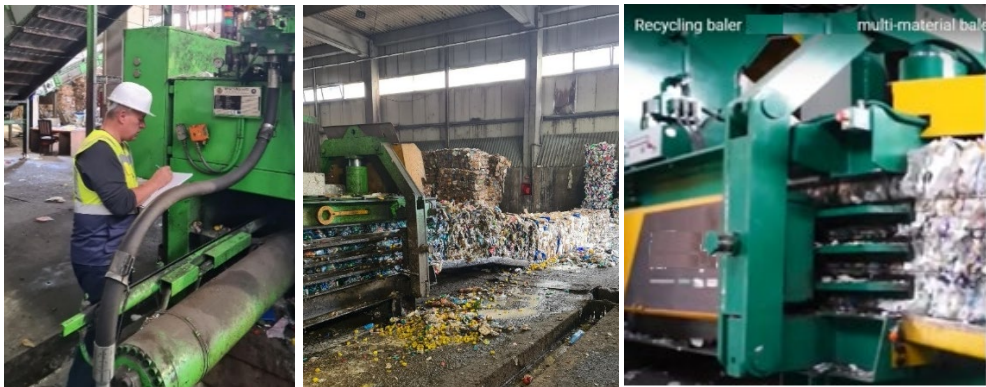
The MAC 107/1 horizontal waste baler (fig.1), used in our experiments, is a baler for municipal solid waste, commercial and industrial waste. It can bale both recyclable plastic waste (PET bottles or various foils), cardboard and aluminium, but also unsorted solid municipal waste with various contents of organic materials or bulky waste. The press has an optimal ratio between pushing force and compaction speed, having a mechanism on the exhaust channel provided to adjust the bale density. It is usually used in transfer stations and landfills, where these materials are recovered in the final phase. Of course, the baling of waste can also be done to make the most of a storage space.

Materials are pressed into high-density parallelepiped bales to reduce storage space and for easier handling and transport with minimal loss. The length of the bales is selectable, the bales being tied automatically when it is reached.

The press consists of the body of the press, the main hydraulic control block, the pressing chamber, the pressing carriage, knife and counter-knife, the feeding basket, the binding device, the counter pressure system and, as the case may be, the wrapping device.

The press chamber and the lower or upper plates are made of Hardox, a superior and wear-resistant material. The body of the press is built from rigid frames, articulated between them, being equipped with the group of pumps and the 2 hydraulic cylinders for compaction.

The experiments were carried out with waste formed from PET food bottles in order to reduce the volume of storage and an easier transport to processing factories that transform them into other useful objects or even bottles for liquid products.



**Figure 2** Aspects during experiments on baling bulky recyclable waste

Interestingly, the press works with large quantities of recyclable bottles which are fed discontinuously into the receiving hopper of the press and fed into the compacting chamber, where a high-powered piston picks them up and feeds them, batch by batch, into the rectilinear pressing chamber, horizontal. Compaction occurs under the effect of the piston pressure and the opposing resistance of the previously formed bales in the exhaust channel, but mainly due to the pressure from the high-power yoke and hydraulic cylinder counter-pressing mechanism. It acts on the side walls of the baling chamber and on the upper one, which are formed by rigid bars articulated to the bale channel.

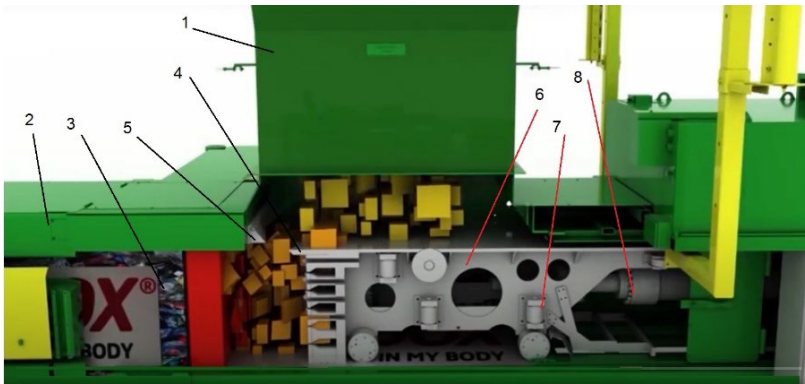
In the case of presses with horizontal flow, the supply of waste is carried out sequentially or continuously, with a feeding belt or with a chute/ inclined plane that discharges the volumes of waste into the vertical bin of the press.

Depending on the settings from the control panel, the carriage of the pressing plate translates the volume of waste and portions it with the help of the knife and the counter knife, pressing it into the existing counterfront of the previous bale.

Depending on the type of waste, the bale tends to be elastic and return to its original shape (for example in the case of PET bottles) or has a plastic behaviour in the case of aluminium cans, less so in the case of cardboard waste (which has a mixed behaviour).

Wire binding is done in 3, 4 or 5 rows depending on the binding device, and this is produced by automatically slowing down the last pressing of the material volume, so as to allow the binding device to bind and cut the binding wire.

In the experiments carried out, the formation of a bale required a feed in 10 complementary stages with relatively identical volumes of material, the resistances encountered at the cylinder of the press piston being relatively identical (for the capacity of the press which is relatively large). The dimensions of the press feed chamber are  $L \times w \times h = 1.2 \times 1.1 \times 0.75$  m ( $0.990 \text{ m}^3$ ), and the dimensions of the press channel are  $l \times h = 1.1 \times 0.75$  m, the stroke of the piston being 1.3 m.



**Figure 3** The pressing system of the horizontal baling press for bulky waste

## RESULTS AND DISCUSSION

From our experiments it appeared that the 10 batches of material each weighed between 32-40 kg, the total bale having an estimated weight of 336 kg and a length of approx. 1.3 m. The physical parameters of the bale formation process are expressed by the data from Table 1.

Starting with the 3rd press, the pressure in the main hydraulic cylinder increases. The pressure gauge on the secondary hydraulic cylinder does not register variations because the setting is to reduce the passage section every 12 seconds, as long as the cycle of a batch (at

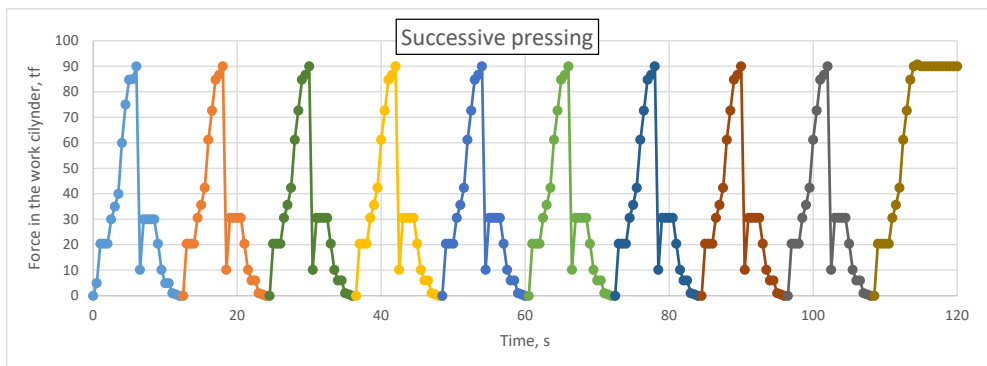
feeding) lasts. From the acquisition of data in the ten stages of bale formation (fig.4), the periodicity of the stages and the data recorded at each stage can be seen.

**Table 1** The parameters of bale formation from PET waste, in the ten stages

No. batch	Quantity per batch kg/batch	Volume of pressing chamber, m <sup>3</sup>	Bulk density, kg·m <sup>-3</sup>	Bale length in formation, m	Successive cumulative bale volume, m <sup>3</sup>	Bulk density of the bale in formation, kg·m <sup>-3</sup>
P1	40	0.990	40.40	0.15	0.12	323
P2	30		30.30	0.30	0.25	283
P3	30		30.30	0.40	0.33	303
P4	33		33.33	0.50	0.41	266
P5	35		35.35	0.60	0.50	339
P6	35		35.35	0.75	0.62	328
P7	32		32.32	0.90	0.74	316
P8	35		35.35	1.00	0.83	327
P9	32		32.32	1.20	0.99	305
P10	34		34.34	1.30	1.10	313

One can easily observe the compaction phases of the material volume fed in front of the pressing piston, as well as its withdrawal phases in order to execute a new work cycle. It is also observed that at the last stage the hydraulic cylinder remains under pressure long enough to tie the bale.

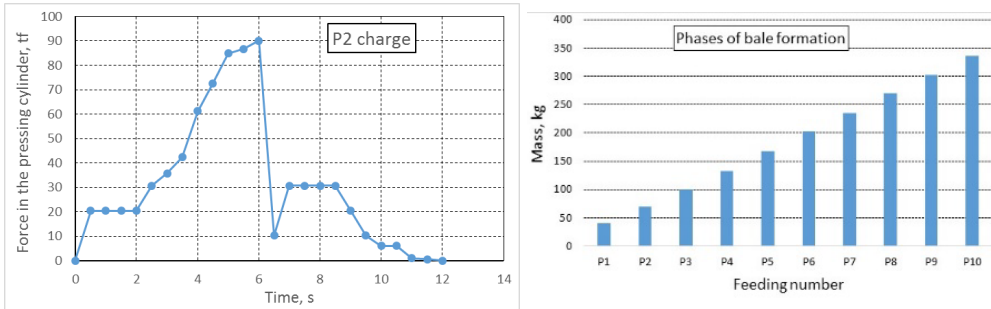
Analysing in detail a pressing cycle, a relatively continuous increase is observed in the first half of it (6 seconds), until the maximum pressing force is reached, with some jumps and variations due to the non-uniformity of the material subjected to pressing.



**Figure 4** Stages of bale formation and force in the hydraulic cylinder versus time



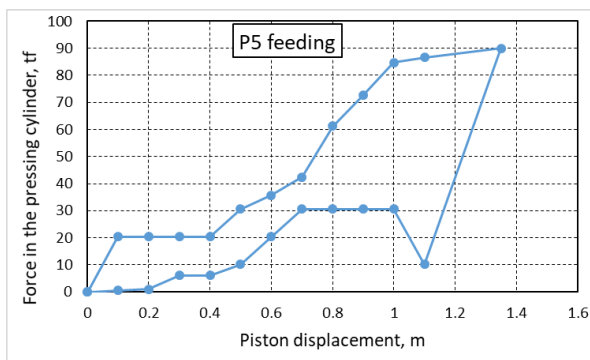
In the second half of the cycle (the next 6 seconds), when the hydraulic cylinder retracts to pick up a new portion of material, the force in the hydraulic cylinder drops to zero. In the first 0.5 seconds of piston withdrawal, the decrease is sudden, but due to the expansion of the material (its elasticity) immediately after that there is a jump up to a value of about 30 tf (ton-force), with a plateau at this value of about 2 seconds, finally the value of the force decreasing (fig. 5).



**Figure 5** Force variation in the working cylinder during a compaction-retraction cycle

If we analyse the forces in the hydraulic cylinder during a work cycle, in relation to the distance travelled, we can identify the energy consumed in the process. Consequently, the area under the two curves (ascending – descending) represents the energy on the compaction phase, respectively on the piston withdrawal phase. The energy stored in the bale that forms is represented by the surface area between the two curves, obtained by the difference between the surface area under the upward curve and the area of the curve under the downward curve.

For the P5 cycle of bale formation, the respective curves are shown in fig.6.



**Figure 6** The variation of the force in the working cylinder in relation to the displacement of the compaction piston

For this period of bale formation (fig.6), our calculations showed that the energy consumed in the compaction phase is about 67.31 tf·m, and in the withdrawal phase the energy consumed

is 29.69 tf·m. So, the mechanical energy stored in the bale (at this stage) is 37.61 tf·m (that is, about 37.61 kJ). If the same energy is consumed in each of the 10 phases of bale formation, then the energy consumed for compaction is approximately 376-380 kJ, which represents approximately 1.12 kJ kg<sup>-1</sup> specific compaction energy. In any case, the energy for obtaining a bale of recyclable PET bottles must also add up the energy values for the other operations, namely tying, wrapping (if applicable), as well as for feeding the pressing chamber.

The energy consumed in the operations of sectioning and isolating the material in the pressing chamber, in each cycle of bale formation, is included in the compaction-pressing energy.

## CONCLUSIONS

The baling of recyclable waste with the help of horizontal presses is carried out in several successive stages, which can be set from the command and control panel of the press. Also from the command and control panel, other process parameters can be set, such as the length of the bale, the type of waste, the density of the bale, the limit pressure in the hydraulic cylinders of the compaction system, the time of a pressing cycle, the binding time.

From what is mentioned in the paper, it can be seen that the force in the hydraulic cylinder for pressing the material increases continuously in the active stroke (pressing stroke), and after reaching the maximum value (at the end of the pressing stroke) it suddenly drops to a minimum value, but due to the expansion of the material returns to a slightly higher value, remaining relatively constant over a length of about 0.3 m, and then continuously decreases until the final withdrawal of the piston and the resumption of a new stroke, i.e. a new refuelling with a new batch of material.

From our experiments, the specific energy consumption for baling PET food bottles was about 1.12 kJ·kg<sup>-1</sup>, for bales formed in ten cycles, having a net mass after binding of more than 335 kg.

This value is indicative, because for other categories of baled recyclable waste and other settings on the horizontal press panel it is very likely that the value of this specific energy will be different.

## ACKNOWLEDGEMENT

The paper was funded both from the project "Ensuring the operation in good conditions of the base of practical agro-mechanical applications in solariums, gardens, orchards and vineyards (BASGLIV)", CNFISFDI-2022-0007, from the Ministry of Education through the Executive Agency for Financing Higher Education, Research, Development and Innovation.

## REFERENCES

- Baldasano J.M., Gassó S., García-Pando C.P. (2003). Environmental Performance Review and Cost Analysis of MSW Landfilling by Baling-Wrapping Technology versus Conventional System, *Waste Management*, 23(9):795-806.
- Cesaro A., Belgiorio V. (2020). The valorisation of residual waste bales by urban mining, *Environmental Science and Pollution Research*, 27(19), 24004–24012.

- Nammari D.R., Hogland W., Moutavtchi V., Marques M., Nimmermark S., (2003). Physical and chemical processes in baled waste fuel, with emphasis on gaseous emissions, *Waste Management & Research*, 21(4):309-317.
- Nammari D.R., Marques M., Hogland W., Mathiasson L., Thörneby L., Martensson L. (2007). Emissions from baled municipal solid waste: II. Effects of different treatments and baling techniques on the emission of volatile organic compounds, *Waste Management & Research*, 25(2):109-118.
- Nammari D.R., Marques M., Thörneby L., Hogland W., Mathiasson L. (2007). Emissions from baled municipal solid waste: I. Methodological approach for investigation of gaseous emissions, *Waste Management & Research*, 25(1):39-48.
- Osamwonyi I., Okokpujie I.P., Dirisu J.O. (2018). Development and performance analysis of horizontal waste paper baling machine, *International Journal of Mechanical Engineering and Technology (IJMET)*, 9(10), pp. 84–101.
- Oteng-Ababio M., Annepu R., Bourtsalas A., Intharathirat R., Charoenkit S. (2018). Urban solid waste management. In Rosenzweig, C., W. Solecki, P. Romero-Lankao, S. Mehrotra, S. Dhakal, and S. Ali Ibrahim (eds.), *Climate Change and Cities: Second Assessment Report of the Urban Climate Change Research Network*. Cambridge University Press. New York. 553–582
- Ozbay I., Durmusoglu E. (2012). Temporal variation of decomposition gases from baled municipal solid wastes, *Bioresource Technology*, 112, 105-110.
- Ozbay I., Durmusoglu E. (2013). Energy content of municipal solid waste bales, *Waste Management & Research*, 31(7), 674-683.
- Palma Lima J., Dias Lobato K.C., Leal F., da Silva Lima R. (2015). Urban solid waste management by process mapping and simulation, *Pesquisa Operacional*, 35(1): 143-163.
- Robles-Mart F., Önez R.E., Gourdon R. (2000). Long-term behaviour of baled household waste, *Bioresource Technology*, 72(2), 125-130.
- Stenis J., Moutavtchi V., Hogland W. (2011). Solid Waste Management Baling Scheme Economics Methodology, *Iranica Journal of Energy & Environment*, 2(2):104-116
- Tello Espinoza P., Villagómez F.G. (2012). Evaluation of leachate generation in wrapped bales urban solid waste: Full scale experiment, *Rev. Internacional de Contaminacion Ambiental*, 28:85-89.
- Yıldız-Geyhan E., Yılan G., Ciftcioglu G., Neşet Kadırgan M.A. (2016). Environmental analysis of different packaging waste collection systems for Istanbul – Turkey case study, *Resources Conservation and Recycling*, 107:27-37.

---

---



## TRAINING FARMERS ON CIRCULAR ECONOMY IMPLEMENTATION: THE TANGO-CIRCULAR PROJECT

Pietro PICUNO<sup>1\*</sup>, Roberto PUGLISI<sup>1</sup>, George SPYROU<sup>2</sup>, Evangelos DIMITRIOU<sup>2</sup>,  
George PAPADAKIS<sup>2</sup>, Maria SMYRNIOTAKI<sup>3</sup>, Violetta KOUTSOGIANNNOPOULOU<sup>3</sup>,  
Christine STAVROPOULOU<sup>4</sup>, Tina PAPASIDERI<sup>4</sup>, Mercè BALCELLS<sup>5</sup>,  
Lluís MARTIN CLOSAS<sup>5</sup>, Luca BRONDELLI DI BRONDELLO<sup>6</sup>, Cristina MATA<sup>7</sup>,  
Anna FARRUS<sup>7</sup>, Fátima BAPTISTA<sup>8</sup>, Vasco FITAS DA CRUZ<sup>8</sup>,  
Maria Elena MUR CACUHO<sup>9</sup>, Teresa BATISTA<sup>10</sup>, Firmino CORDEIRO<sup>11</sup>,  
Zoe GODOSI<sup>12</sup>, Delphine MARGOUT-JANTAC<sup>13</sup>

\*E-mail of corresponding Author: [pietro.picuno@unibas.it](mailto:pietro.picuno@unibas.it)

<sup>1</sup>University of Basilicata - SAFE School (UNIBAS), Italy.

<sup>2</sup>Agricultural University of Athens (AUA), Greece

<sup>3</sup>EUROTRAINING, Athens, Greece

<sup>4</sup>INASO-PASEGES, Athens, Greece

<sup>5</sup>University of Lleida, (UdL) Spain

<sup>6</sup>ENAPRA-Confagricoltura, Italy

<sup>7</sup>Federació de Cooperatives Agràries de Catalunya (FCAC), Spain

<sup>8</sup>University of Evora, Portugal

<sup>9</sup>IPCENA, Spain

<sup>10</sup>Comunidade Intermunicipal do Alentejo Central (CIMAC), Portugal

<sup>11</sup>Associação dos Jovens Agricultores de Portugal (AJAP), Portugal

<sup>12</sup>Unione delle Province Italiane - Regione Puglia (UPI), Italy

<sup>13</sup>University of Montpellier, France

### ABSTRACT

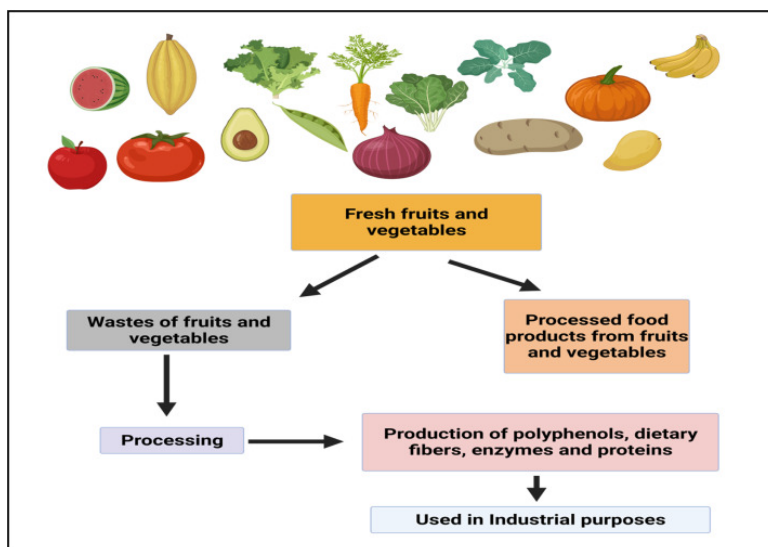
*The volume of waste produced by agricultural activities is constantly rising, due to the continuous increase of crop and livestock production, aimed to cover the nutritional needs of the accreting population of the planet. This enormous mass of wastes has a significant environmental impact. A very promising way to reduce the environmental footprint of agriculture, passes through the valorization of agricultural co-products, by-products, residues and waste, as well as other materials - such as plastics - widely used for crop cultivation and animal production, after the end of their working life. In order to involve farmers to play an active role on this issue, contributing to transform what they currently consider as a "waste" into a new resource, under the perspective of a circular economy and for a more sustainable agriculture, the Project*

*TANGO-Circular has been financed by the EU Erasmus+ Programme. Aim of this Project is to contribute to the development of regional ecosystems, directly providing valuable economical inputs by integrating, through a Quadruple-Helix approach, innovative solutions, with a work-based learning. Core of the Project is the design, implementation and validation of some “Rural Labs”, in which farmers and other relevant stakeholders will be trained through a “knowledge-driven” approach. There, new ways of training will be explored, for the sake of a larger audience of trained people, working in the Project Countries as well as in the rest of Europe.*

**Keywords:** Sustainable agriculture, waste valorization, Rural Labs, new entrepreneurship, Quadruple-Helix approach.

## INTRODUCTION

It is well known that climate change is affected and affects to a large extent agriculture and animal husbandry. According to the current climate state, the need to transition to a more sustainable situation, mainly regarding the agricultural and livestock sector, is now almost inevitable. Also, the energy crisis that Europe is currently facing, reinforces the exigence to find new ways of producing energy. As agriculture and livestock activities produce a lot of unexploited remains, methods for utilizing these residues, industrial by-products and co-products, appear to be the key to this problem. The valorization of agro-livestock organic and non-organic wastes is a technique applied in rural areas for the production of energy and for manufacturing new value-added products such as soil improvers, animal feed, biofuels etc. (Yaashikaa et.al., 2022). Below, a graphical display of the fate of fruits and wastes is presented in figure 1.



**Figure 1** The fate of processed fruits and vegetables. (Source: Dey et.al., 2021, Valorization of agro-waste into value added products for sustainable development.)

Field and Industrial by-products of agricultural crops or animal by-products as well as plastics used in these sectors, can be classified into organic and non-organic wastes. The most common wastes are presented on Table 1.

**Table 1** Classification Of Agricultural and Livestock wastes

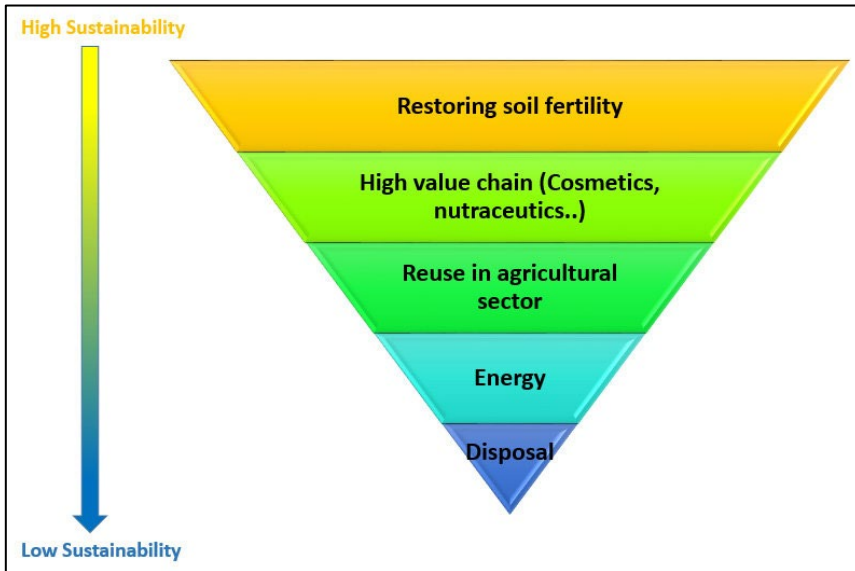
Organic waste				Inorganic waste
Agricultural		Livestock		Agro-livestock by-products
Field plant by-products	Industrial Plant by-products	In farm animal by-products	Industrial animal by-products	Agro-livestock plastics
<b>Herbaceous Crops</b> straw, leaves, stems, husks, cane, flowers, scraps, no seed plant parts	Rice/sunflower etc. husks	Solid & liquid manure	Animal droppings	Plant Protect Product packages
	Peels	Animal bedding	Fat	Irrigation tubes
	Seeds	Damaged feeders	Skin	Crop protection plastics
<b>Vegetable Crops</b> leaves, stems, discarded fruits, bulbs, tubers, roots	Nut shells	Other remains	Hoofs	Fertilizer bags
	Pressed grape drags		Feathers	Plastic animal feed bags
	Pomaces		Hairs	Vineyard Nets
<b>Orchard Crops</b> tree prunings, leaves, discarded fruits or flowers	Press cake	Other remains	Eggshells	Mulching films
	Bagasse		Other remains	Landscape fabric
	Other remains			Other remains

Concerning the environmental, financial and energy issues that have arisen, appropriate education of the farmers appears to be necessary. Producers as well as society must be informed about the need to transition to a new sustainable model following the rules of the circular economy.

In the context of this necessity, Erasmus<sup>+</sup> and EU funded the TANGO-Circular Project. The core of the project is to clarify to the producers and the relevant stakeholders, that utilization of the unusable remains of the crops or animal farms may enhance their financial input and simultaneously contribute to reducing the ecological footprint of their agro-livestock activities (Manniello et al., 2021).

Farmers constitute the main gear of food and economic chain, so their role on the adoption and implementation on new sustainable methods in the framework of circular economy is important (Picuno, 2016). Unfortunately, most usual methods farmers follow regarding agro-livestock wastes management, are burning or burial depending on the type of waste. This

strategy has been followed by farmers over the years and is still followed on a smaller scale, due to lack of legislation framework and to insufficient information about the impact such activities can cause. As farmer's and other stakeholder's activities affect in a great extent many sectors such as environmental, economic, food etc., they deserve a proper information about current environmental situation and a specific training in agricultural circular economy (Baptista et al., 2021).



**Figure 2** Agricultural by-product, co-product and waste management hierarchy (Statuto et al., 2019).

TANGO-Circular Project sets as a goal the collaboration of five (5) European Countries (France, Greece, Italy, Portugal and Spain) from Mediterranean Europe, for the development of an educational program that includes state-of-art technologies regarding collection, transportation, valorization of agricultural wastes, significant information about legislative, economic, social and technical sector, as well as many more topics, so the EU producers can acquire elementary and profound knowledge. The implementation of the project objectives is carried out according to a Quadruple-Helix approach, involving Public Authorities (Regional/Local Ministries/Agencies, etc.), RTD performers/ VET providers, Private stakeholders (Farmers Associations, Collectors/Recycling Firms/Associations, etc.) and the Civil Society (NGO, No-profit Associations, etc.). The pivotal venture conducted by the Project, is the modelling and implementation of some "Rural Labs" in which, under the coordination of the Partner Universities, expert in agricultural waste management, the farmers and other relevant stakeholders will be trained. The main view of these Rural Labs is the execution of new, interactive training models, combining an on-site training with the implementation of new ICT tools, to be produced for the sake of a larger audience of trained people, working in the Project Countries as well as in the rest of Europe.



## OBJECTIVES

Currently in Europe, there is no such approach to the training of farmers, who very often find themselves managing waste plastic streams and agricultural residues without the right technical skills, without knowing the good practices that could lead to a proper exploitation of the streams themselves. The TANGO-*Circular* project is in line with the EU Common Agricultural Policy and needs a European approach in order to contribute to the achievement of the requirements a) to ensure the continued "greening" of this policy and b) to decrease any adverse effects of agriculture on the environment. Indeed, it aims at bringing together major stakeholders of the agricultural sector, including agricultural workers (farmers). The idea behind this approach is to ease the transfer of technological advancements of the agricultural sector from the laboratories directly to the people involved in the process. By creating a European consortium, the project aims at facilitating the transfer of advancements from every European country research institute to each farmer within the EU.

Furthermore, the direct communication between agricultural workers is a major advantage of the virtual environment that this project wishes to implement. The new strategy intends to take on the burden of managing waste from all major sectors; while recycling targets exist for some of them, for others (e.g., construction and agriculture) they are currently not defined, and separate legislation exists for the different waste typologies. Among others, it is interesting to focus on plastics used in the agricultural sector (Briassoulis et al., 2013; Picuno, 2014). Furthermore, the EU analysis specifies that a large proportion of this waste could be burnt or dumped in fields, as audits of collection systems have shown that none of them collects more than 70% of the agro-plastic (Briassoulis et al., 2010; Picuno C. et al., 2020). The objectives for the future will be to improve the collection and recycling rates of this waste and, where possible, to try to replace it in alternative ways.

For this to have an actual value, European cooperation is needed, in order to include agricultural workers from across Europe. In this way, they will be able to exchange opinions about by-products and waste, on the possible valorization process, on whether or not the process of valorizing a certain type of waste or agricultural residue is worthwhile, and other issues with colleagues from around Europe. Nowadays, agricultural workers have to be more creative in order to compete in a globally demanding market. Sustainable agriculture and use of environmental technologies are key elements to a successful agricultural business of tomorrow. Exchange of experiences about these issues with other agricultural workers across Europe that may have experimented in the past is significant for the success. The cooperation between various European partners will allow for the transparency, comparability, transferability and recognition of qualifications, between the participating countries and will lead to a joint training program that makes the various stakeholders aware of the good practices of exploitation of flows in the perspective of a circular economy. The project results will be in this way exploitable practically in every European country. Initially, stakeholders from the participating countries will be invited and afterwards the results will be disseminated to all major European associations and research institutes of agriculture.

The specific objectives that this hands-on training will try to achieve are numbered below:

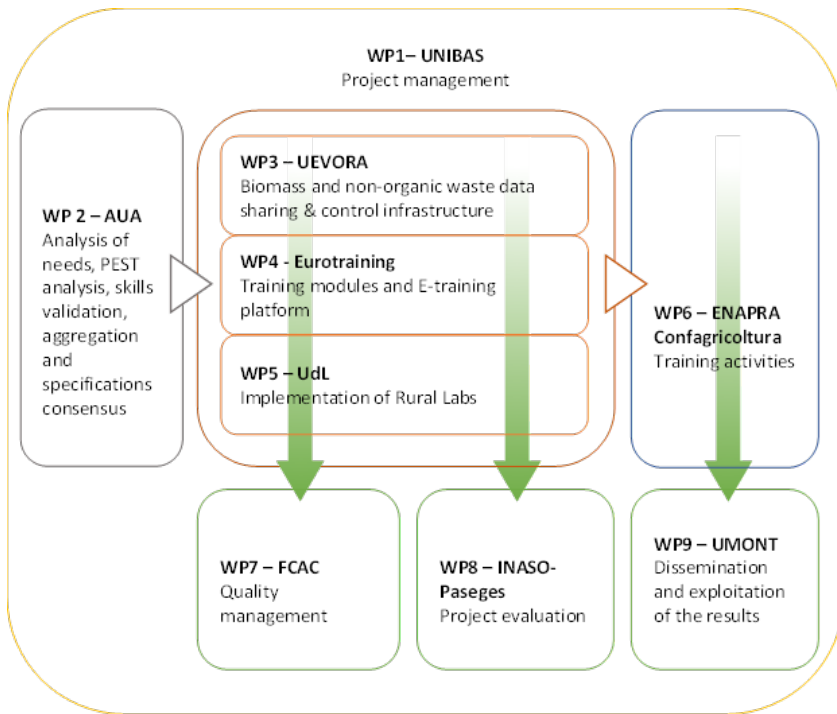
- Training 1000 farmers (*i.e.*, 250 farmers in each one of the four Rural Labs) and a total of 200 stakeholders (*i.e.*, 50 stakeholders in each one of the four Rural Labs) in EU along the project

- Stimulate new entrepreneurship in the field of collecting, transporting and re-using biomass coming from agricultural co-products, by-products residues and waste, as well as in the field of agricultural plastic collection, transportation and mechanical recycling.
- Boosting innovation through developing and implementing new multidisciplinary approaches to teaching and learning.
- Developing a sense of initiative and entrepreneurial mind-sets, competences and skills, opening up new learning opportunities for farmers and stakeholders playing a key-role in waste management chain.
- Stimulating the flow and exchange of knowledge between higher education, VET, enterprises and research, in the framework of a Quadruple-Helix approach.
- Identifying resilience-related, market needs and emerging professions, including via the cooperation of HEIs and VET providers with national, regional and local authorities, as well as the private sector, to contribute to designing and implementing Smart Sustainable Specialization Strategies (S4) in their regions.
- Develop and implement new multidisciplinary curricula for the valorization of agricultural wastes in the framework of a Circular Economy, by implementing new digital skills.
- Test new learning tools for teaching and learning, learner-centred and customized on the requests coming from the people to be trained (*e.g.*, video tutorials, “didactic pills”, *etc.*). Along the whole Projects, at least 20 video-tutorials and 40 didactic pills, translated in all the languages of the participating Countries, will be produced;
- Development of a specific model of rural living labs – 4 Rural Labs - in the participating countries and to validate its replicability at EU level as an innovative organizational model to develop Sustainable Circular Business models in rural communities.
- Compilation, selection, and optimal configurations of state-of-the-art technologies.
- Political, Economic, Social and Technical (PEST) analysis.
- Training Needs Validation and Curriculum Design.
- Identification of new skills for future professionals.
- Identify alternative business models for waste collection and treatment based on farmer needs, as input to public policies.

## METHODOLOGY

The TANGO-*Circular* Project follows a well-defined methodology for the preparation, design and delivery of the training program. The Workplan (figure 3) has been conceived to be lean and structured to accommodate as many users as possible and can be schematically described as follows:

- Analysis of the skills acquired by agricultural workers based on the latest research in the scientific bibliography, to provide a good scientific basis.
- Providing a training program that is comprehensive and detailed in all its parts.
- Strengthening of the users' curricula, and provide strong capacity to the user being trained.
- Development of smart skills so that they can be used by the final operator.



**Figure 3** Overall Workplan structure.

## TRAINING PROGRAM

The TANGO-*Circular* training program will be organized into the following nine (9) training modules:

1. Classification of agricultural biomass.
2. Valorization of agricultural biomass.
3. Valorization of agro-food co-products, byproducts and organic residuals.
4. Classification of agricultural plastic waste.
5. Collection, transportation and recycling of Agricultural Plastic Waste.
6. De-contamination and valorization of Agricultural Plastic Packaging Waste.
7. Waste/Biomass legislation.
8. Environmental, territorial and economic planning, associated with each form of valorization.
9. Advantages and disadvantages associated with each possible form of valorization.

Each module will have a duration of eight hours of blended learning, organized into:

- 2 hours of face-to-face lessons
- 2 hours of demonstration at the Rural Lab
- 2 practical training at the Rural Lab
- 2 hours of online learning.

Each module will enable to be credited for 0.5 ECTS/ECVET points.

## CONCLUSIONS

Trainees in the field of agriculture and youth farmers, as well as relevant stakeholders and enterprises involved in the specific sector's activities, will benefit from the short, medium and long-term effects of the Project. Taking into consideration that in the EU Mediterranean Countries the agriculture sector has a significant representation in the labor market, it is recognizable that the acquisition of digital and green skills for the youth, who intend to work in that field, are fundamental prerequisites. Indeed, the implementation of the project's activities shapes great potential to offer tailor-made opportunities in youth trainees - farmers and employees in the agricultural sector - to obtain competencies and skills according to the existing and emerging needs in that field. The coherent set of activities included in the Project will therefore have a significant socio-economic impact, since it will capitalize the potential of young people to tackle the challenges and initiatives in the agriculture sector. It is important to refer to the impact of the project in the labor market and the long-term effects. Specifically, enterprises and stakeholders in the field would have the opportunity to upgrade their efforts to minimize the agricultural waste. The harmonization with the rules of circular economy stresses the crucial importance of implementing new multidisciplinary approaches to teaching and learning, fostering education programs and activities within agricultural enterprises.

## ACKNOWLEDGEMENTS

The TANGO-*Circular* Project is Co-funded by the Erasmus<sup>+</sup> Program of the European Union (Project: 101055970 — TANGO-*Circular* — ERASMUS-EDU-2021-PI-ALL-INNO).

## REFERENCES

- Baptista F., Lourenço P., Fitas da Cruz V., Silva L.L., Silva J.R., Correia M., Picuno P., Dimitriou E., Papadakis G. (2021). Which are the best practices for MSc programmes in sustainable agriculture? *Journal of Cleaner Production*, 303, 126914, pp. 1-10.
- Briassoulis D., Hiskakis M., Scarascia Mugnozza G., Picuno P., Delgado C., Dejean C. (2010). Labelling Scheme for Agricultural Plastic Wastes in Europe. *Quality Assurance and Safety of Crops & Foods*, (2), 93-104.
- Briassoulis, D., Babou, E., Hiskakis, M., Scarascia-Mugnozza G., Picuno P., Guarde, D., Dejean, C. (2013). Review, mapping and analysis of the agricultural plastic waste generation and consolidation in Europe. *Waste Management and Research*, 31 (12): 1262-1278.
- Dey, T., Bhattacharjee, T., Nag, P., Ritika, Ghati, A., Kuila, A. (2021) Valorization of agro-waste into value added products for sustainable development, *Bioresource Technology Reports*, 16, 100834, ISSN 2589-014X.
- Manniello C., Statuto D., Di Pasquale A., Picuno P. (2021). Planning the Integrated Management of Organic Waste Flows and Agricultural Residues for a Circular Economy. *Proceedings of the European Conference on Agricultural Engineering - AgEng2021*, 4 – 8 July 2021, Evora (Portugal), Vol. 1, pp. 137-145.
- Picuno P. (2014). Innovative Material and Improved Technical Design for a Sustainable Exploitation of Agricultural Plastic Film, *Polymer - Plastics Technology and Engineering*, 53:10, 1000-1011.
- Picuno P. (2016). Use of traditional material in farm buildings for a sustainable rural environment. *International Journal of Sustainable Built Environment*. 5 (2): 451-460.

- Picuno C., Alassali A., Sundermann M., Godosi Z., Picuno P. & Kuchta K. (2020). Decontamination and recycling of agrochemical plastic packaging waste. *Journal of Hazardous Materials*, Vol. 381, 5 January 2020, Article number 120965.
- Statuto D., Frederiksen P. & Picuno P. (2019). Valorization of Agricultural by-products within the "Energyscapes": Renewable energy as driving force in modeling rural landscape. *Natural Resources Research*, Vol. 28, No. SI, August 2019, S111- S124. <https://doi.org/10.1007/s11053-018-9408-1>.
- Yaashikaa P.R., Senthil Kumar P., Varjani S. (2022). Valorization of agro-industrial wastes for biorefinery process and circular bioeconomy: A critical review, *Bioresource Technology*, 343, 126126, ISSN 0960-8524.

---

---



## THE ENERGY POTENTIAL OF THE BREWERS' SPENT GRAIN IN SMALL CRAFT BREWERIES – CASE STUDY “ZMAJSKA PIVOVARA”

Nikola BILANDŽIJA<sup>1\*</sup>, Andrea PUŠKARIĆ<sup>2</sup>, Neven VOĆA<sup>3</sup>, Vanja JURIŠIĆ<sup>3</sup>, Jona ŠURIĆ<sup>3</sup>, Anamarija PETER<sup>3</sup>

\*E-mail of corresponding author: nbilandzija@agr.hr

<sup>1</sup>Department of Agricultural Engineering, Faculty of Agriculture, University of Zagreb, Svetošimunska Cesta 25, 10000 Zagreb, Croatia

<sup>2</sup>Poljonova d.o.o., Industrijska cesta 34, Sesvete, Croatia

<sup>3</sup>Department of Agricultural Technology, Storage and Transport, Faculty of Agriculture, University of Zagreb, Svetošimunska Cesta 25, 10000 Zagreb, Croatia

### ABSTRACT

*In the food industry, significant amounts of biodegradable residues are generated during the production process. The disposal of such raw materials represents an environmental problem and additional cost for any primary production, including beer production. Brewer's grains account for about 85% of the total by-products in beer production. Disposal of by-products is a one of the major challenges for the beer industry, as large quantities of brewer's grains are produced, the market value is low, and the high moisture content makes further processing difficult. In Croatia, most brewer's spent grain are currently composted, disposed of in landfills, or sold as animal feed. In urban areas, the disposal of brewer's spent grain can cause problems during the primary business. In this paper, using the example of the small brewery "Zmajska pivovara" - Zagreb, Croatia, the possibility of disposing of brewer's spent grain by generating energy through direct combustion is investigated.*

**Keywords:** brewer's spent grain (BSG), disposal, properties, combustion

### INTRODUCTION

In general, biowaste includes kitchen and garden waste from households, biodegradable waste from parks, food and waste from catering establishments, biodegradable waste from food production and processing plants, wood waste from the wood processing industry, harvest and pruning residues from agriculture, etc. (Pavlas et al. 2020).

Brewer's spent grain (BSG) is a lignocellulosic material that represents insoluble components produced after fermentation, immediately before fermentation, and accounts for approximately 85% of all brewery byproducts. The production of wort results in 100-130 kg of wort per 100 kg of malt (about 20 kg of BSG per 100 l of beer) with a moisture content between 70-80%. Beer is produced and consumed throughout the year, so large quantities of brewer's spent grain are produced, which can be an environmental problem if not disposed of properly. In order to preserve the quality of brewer's spent grain, but also to extend their shelf life, they should be dried. The dried tropical fruit should be reduced to about 10% moisture. Drying not only prevents spoilage, but also reduces the volume of the fruit, which facilitates storage and transportation (Mussatto et al. 2006; Karlović et al. 2020). Brewer's spent grain has a high moisture content (~77-81%) and are therefore susceptible to spoilage due to microbiological activity. A dryer and pelletizer are required for direct combustion. Boilers for direct combustion may have a built-in or separate stainless steel tank for hot water. Boilers have the possibility to install a device for automatic addition of pellets into the combustion chamber. All system parameters are digitalized, which allows automation of the system and remote control of the process (Nordholm, 2020).

The chemical composition of the brewer's spent grain depends on the type of grain variety, the harvest period, the wort, and the grain size of the malt mash. The most common composition of BSG (% dry matter) is: cellulose (25.4%), hemicellulose (21.8%), lignin (11.9%), proteins (24%), lipids (10.6%), ash (2.4%) and some secondary components such as ferulic acid, coumaric acid, etc. The lignin contained in brewer's spent grain has a complex structure, high molecular weight, is chemically stable and insoluble. It is a limiting factor in biogas production (it hinders hydrolysis of fibres), but has good fuel properties (lignin is not desirable for anaerobic decomposition, but is for combustion). Roasted malt reduces the degradability of lignin in the tropics and increases its calorific value. The lignin content depends on the barley variety and the type of malt (Kanauchi et al. 2001; Praveen et al. 2010; Manyuchi et al. 2016).

The aim of the study is to determine the possibility of energetic utilisation of brewer's spent grain by generating energy through direct combustion based on the case study of the microbrewery "Zmajске pivovara". In order to achieve this goal, it is necessary to perform an energy analysis of the studied raw material and determine the annual production of brewer's spent grain. On the basis of the obtained data, a calculation of the potential energy generated by direct combustion of the resulting brewer's spent grain was performed.

## MATERIALS AND METHODS

### *Materials*

The first Croatian craft brewery, "Zmajска pivovara", Zagreb, Croatia (picture 1), started operations in 2014, and in the same year its porter was included in the list of the 15 best porters in the world on the Ratebeer portal, and "Zmajска pivovara" was declared one of the 10 best newly opened breweries in the world in competition with 3,800 other breweries. From 2014 to the present, over 70 types of beer have been produced. The capacity of the brewery is 500,000 liters per year, and recently the 6,000,000th bottle was bottled. The permanent offer today consists of 5 beers (picture 2) of different styles: pale ale (Pale Ale), porter (Porter), IPA (Pozoj), pilsner (Pils) and Session IPA (Therapy Session IPA). „Zmajска pivovara“ brews seasonal beers and special beers throughout the year and introduces at least



one such beer per month, so in addition to the 5 beers in the permanent offer, ten other special beers and unique beers are regularly offered for sale.



**Picture 1** Production facility of "Zmajška pivovara"



**Picture 2** Permanent assortment of "Zmajška pivovara" beers

Sampling of BSG (picture 3) was performed immediately after separation of BSG and pomace at the outlet of the boiler. In order to determine the amount of BSG in relation to the amount of input raw material (beer malt pomace), a pallet (with a measuring scale) was used for weighing. The procedure was performed twice a day for three consecutive days (April 2021). Each day, an average subsample was taken for further laboratory analysis of the BSG. The analyses of the samples were performed at the University of Zagreb, Faculty of Agriculture.



**Picture 3** Brewer's spent grain trope during measurements

### **Methods**

The content of water (HRN EN 18134-2:2015), ash (HRN EN 18122:2015), fixed carbon (calculated) and volatile matter (HRN EN 18123:2015) was determined using standard analytical methods. The content of total carbon, hydrogen, nitrogen and sulfur was carried out

by the dry burning method according to the standards for carbon, hydrogen and nitrogen (HRN EN 16948:2015); sulfur (HRN EN 15289:2011). The calorific value is determined according to the standard ISO (HRN EN 14918:2010). For CHP systems, the primary energy is divided into the efficiency of the energy conversion system. If the selected energy conversion system has an electrical energy efficiency of 20%, the total primary energy is multiplied by  $\eta=0.2$ . The rest of the energy refers to thermal energy and losses.

## RESULTS AND DISCUSSION

### *Production of brewer's spent grain*

Based on the data on the amount of malt pomace and the amount of brewer's spent grain, the amount of BSG produced was calculated for a three-year period, i.e., for 2018, 2019, and 2020 (Table 1). Due to the pandemic caused by the coronavirus, beer consumption decreased in 2020, which affected the reduction in the amount of beer produced by about 35%. The year 2019 was used as the reference year for the further evaluation.

**Table 1** Amount of brewer's spent grain

Year	Amount of wet BSG (t/year)
2018	143
2019	169
2020	111

### *Analysis of the brewer's spent grain*

For the energy analysis of biomass as an input raw material in combustion processes, energy-relevant parameters and the elemental composition of the biomass were determined. The energetic parameters summarise the percentage of moisture, ash, fixed carbon, volatile matter, and lower heating value, while the basic elemental analysis includes chlorine, carbon, hydrogen, nitrogen, oxygen, and sulphur. Table 2 shows the chemical analysis of the studied trope, i.e. the basic parameters required to assess the suitability of a feedstock for energy conversion.

**Table 2** Analysis of "Zmajska pivovara" brewer's spent grain (d.m.)

Sample	MCwb* (%)	Ash (%)	Cfix (%)	VM (%)	N (%)	C (%)	S (%)	H (%)	O (%)	LHV (MJ kg <sup>-1</sup> )
I	76.99	3.35	15.55	77.82	2.35	50.38	0.61	6.42	40.25	18.06
II	76.77	3.06	15.97	77.42	2.88	49.49	0.87	6.31	40.45	18.12
III	77.04	3.52	15.68	77.70	2.62	50.21	0.71	6.20	40.27	18.14
<b>Avg.</b>	76.45	3.31	15.73	77.64	2.61	50.03	0.73	6.31	40.32	18.11

\*MCwb – moisture content (wet basis); Cfix – Fixed Carbon; VM – volatile matter; LHV – lower heating value

The water content in the BSG ranges from 70% to 80%, and the average water content in the investigated BSG from "Zmajska pivovara" is 76.45%. Water in the BSG is one of the main causes of spoilage, so it must be dried if longer storage is required. During combustion, water is undesirable because it prevents combustion or some of the heat energy is lost due to water evaporation (Demirbas 2008; Praveen et al. 2010; Molinoa et al. 2016).

Ash consists of mineral matter that does not burn, and its proportion is as low as possible. In agricultural biomass the ash content ranges from 2.3% to 23%, in forest biomass up to 0.55%. Oxygen (average share in biomass between 33% and 45%) as well as nitrogen (up to 2% share in biomass) and sulfur are undesirable parameters. At low combustion temperatures, water is released which, in combination with sulfur dioxide, forms corrosive acids that destroy the equipment of the combustion system. Biomass usually contains only small amounts of sulfur, so it does not pose significant environmental problems (Demirbas 2008; Praveen et al. 2010; Molinoa et al. 2016). The carbon fraction takes the largest part, as in all fuels, between 37% and 46% in agricultural biomass and about 50% in forest biomass. In biomass, carbon is present free and in bound form (Cfix), in compounds with hydrogen, nitrogen, and oxygen. The calorific value of nitrogen is 33,829 MJ kg<sup>-1</sup>. The proportion of hydrogen is small (about 5%), but its heating value is 142,014 MJ kg<sup>-1</sup> (Demirbas 2008; Praveen et al. 2010; Molinoa et al. 2016).

Lower heating value (LHV) is the heat released during combustion without the return of thermal energy spent on condensation of water vapor. Because of the high combustion temperatures, the water takes the form of water vapor, which stores a small portion of the energy released during combustion as latent heat of vaporization; simply put, the heat energy is stored in the water vapor. The lower heating value is used as the basis for selecting a gas engine, cogeneration unit, or combustor. The LHV of BSG from "Zmajska pivovara" is 18.11 MJ kg<sup>-1</sup>. In the study by Jurišić et al. (2019), the trop of three different types of BSG analyzed and it ranged from 17.90 MJ kg<sup>-1</sup> to 18.33 MJ kg<sup>-1</sup>. According to Villarini et al. (2019), the LHV of grape pomace was 18.60 MJ kg<sup>-1</sup> and of olive pomace was 19.00 MJ kg<sup>-1</sup> (Demirbas 2008; Praveen et al. 2010; Brown 2011; Molinoa et al. 2016).

### *Energy potential obtained by direct combustion*

Table 3 shows the characteristics of the BSG required to calculate energy production by direct combustion. Capacity was estimated by the year in which the most feedstock was available for processing, which in this case is 2019.

**Table 3** Energy potential obtained by direct combustion of BSG

Year	Amount of BSG (t <sub>76,45%</sub> y <sup>-1</sup> )	Amount of BSG (t <sub>10%</sub> y <sup>-1</sup> )	Primary energy (MJ)	Secondary energy * (MJ)	Electrical energy ** (kWh)	Thermal energy (kWh)
2018	143	48	869,280	695,424	32,839	121,699
2019	169	55	996,058	796,846	37,629	139,448
2020	111	37	670,070	536,056	25,314	93,809

\*  $\eta=0,8$

\*\* The power generation is calculated on the basis of a steam turbine with an electrical efficiency of  $\eta=17\%$  and an overall efficiency of 80%

If the heat is used for cogeneration, there are additional costs for a turbine with generator, a system for transferring electrical energy, and a system for transferring thermal energy. If energy is to be generated from BSG during the heating season (5000 operating hours), the required nominal heat output of the hot water boiler would be 45 kW. If the heat energy is to be generated throughout the year ( $8760 \text{ h year}^{-1} - 760 \text{ h operating period}^{-1} = 8000$  working hours), the required nominal heat output of the hot water boiler would be 28 kW. To provide flexibility to the brewery, it is necessary to find a boiler that falls within the specified ranges. For example, a hot water boiler with a rated heat output of 20 to 50 kW can be designed to burn solid fuel, pellets, oil or gas. The boiler may also have a built-in water tank. If the heat is to be used for heating production processes (e.g. dryers), an accurate supply and metering of hot water is required, so an additional buffer tank is necessary.

## CONCLUSION

The disposal of BSG can be a significant problem in the main business of any brewery, especially in urban areas where livestock are not even raised. The use of this raw material in power generation processes is one of the options for the disposal of BSG. Since it is a very wet raw material, it is necessary to provide a modern facility for its conversion into a suitable form. Taking the example of the microbrewery "Zmajске pivovara", it was estimated that direct combustion of pre-dried and pelletized BSG would cover about 35% of the electricity demand and 45% of the heat energy demand. Using the BSG only for thermal energy production would cover 78% of the brewery's needs.

## REFERENCES

- Brown R. (2011). *Thermochemical Processing of Biomass, Conversion into Fuels, Chemicals and Power*. Book, e-ISBN:9781119990840, Iowa, USA.
- Demirbas A. (2008). Biofuels sources, biofuel policy, biofuel economy and global biofuel projections, *Energy Conversion and Management*, 49(8) 2106-2116.
- Jurišić V., Škorić D., Matin A., Krička T., Grubor M. (2019). Pyrolysis of BSG with the aim of gaining energy and added-value products. Proceedings of the 47th Symposium "Actual Tasks on Agricultural Engineering", University of Zagreb Faculty of Agriculture, Opatija, Croatia March 5-7, 2019, 389-397.
- Kanauchi O., Mitsuyama K., Araki Y. (2001). Development of a functional germinated barley foodstuff from brewers' spent grain for the treatment of ulcerative colitis. *Journal of the American Society of Brewing Chemists*. 59:59–62.
- Karlović A., Jurić A., Čorić N., Habschied K., Krstanović V., Mastanjević K. (2020). By-Products in the Malting and Brewing Industries-Re-Usage Possibilities. *Fermentation*, 6(3), 82.
- Manyuchi M. M., Frank R. (2016). Techno-economic feasibility of using sorghum brewers spent grain to generate one megawatt of electricity. 47th Ghana Institution of Engineers (GhIE) Annual Conference, Accra, Ghana, 29-30.
- Molinao A., Chianeseb S., Musmarrab D. (2016). Biomass gasification technology: The state of the art overview, *Journal of Energy Chemistry*, 25(1), 10-25.
- Mussatto S.I., Dragone G., Roberto I.C. (2006). Brewers' spent grain: generation, characteristics and potential applications. *Journal of Cereal Science*, 43:1-14.

- Nordholm H (2020) Process design for utilizing spent grain as a potential energy source for craft breweries, Graduation thesis. Department of Chemical Engineering Lund University, Sweden.
- Pavlas M., Dvořáček J., Pitschke T., Peche R. (2020). Biowaste Treatment and Waste-To-Energy-Environmental Benefits, *Energies*, 13(8).
- Praveen J., Jitendra P.L., Stefan C. (2010). Issues with utilisation of brewers' spent grain, *Stewart Postharvest Review*, 6(4):1-8.

---

## **COMMERCIAL PAGES**

---

# POLJO-NOVA



**DEUTZ**  **FAHR**



**POLJO-NOVA d.o.o.** je poduzeće nastalo na 50-godišnjoj tradiciji Poljoopskrbe-Zagreb, dugogodišnjeg nezaobilaznog partnera poljoprivrednika. Sada već sa 70 godina tradicije, iskustva te kontinuiranim rad s renomiranim proizvođačima poljoprivrednih strojeva i opreme kao što su DEUTZ-FAHR, KUHN, Stoll, Capello, Pronar, Garant Kotte, stvorili smo povjerenje i sigurnost u odabiru najkvalitetnije mehanizacije za potrebe svakog poljoprivrednog gospodarstva. Specijalizirani smo za prodaju i servis poljoprivrednih traktora, kombajna, traktorskih prikolica, cisterni za prijevoz gnojivke, poljoprivrednih strojeva i opreme za obradu tla, sjetvu i silažu, te prodaju rezervnih dijelova.

Otvorenim poslovnicama na tri lokacije (Sesvete ZG, Đakovo i Bizovac) stvorili smo logističku mrežu u Hrvatskoj koja svaku nabavu rezervnih dijelova i servisnu intervenciju čini jednostavnom i brzom, a pristupačnost našim korisnicima je na visokoj razini.



Prodajno - servisni centar Sesvete (ZG)  
Industrijska cesta 34  
10360 Sesvete  
tel.: 01/2040-280  
Email: info@poljonova.hr



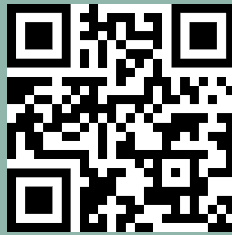
Prodajno - servisni centar Đakovo  
Ul. Petra Preradovića 209  
31400 Đakovo  
Tel.: 031/654 - 033  
Email: info@poljonova.hr



Prodaja rezervnih dijelova Bizovac  
Sunčana 2  
31222 Bizovac  
Mob.: 099/265 - 0224  
Email: info@poljonova.hr







<https://atae.agr.hr/>