

FACULTY OF AGRICULTURE UNIVERSITY OF ZAGREB
AGRICULTURAL ENGINEERING DEPARTMENT
FACULTY OF AGRICULTURE UNIVERSITY OF OSIJEK
FACULTY OF AGRICULTURE UNIVERSITY OF MARIBOR
AGRICULTURAL INSTITUTE OF SLOVENIA
CROATIAN SOCIETY OF AGRONOMISTS
CROATIAN AGRICULTURAL ENGINEERING SOCIETY
CROATIAN AGRICULTURAL EXTENSION INSTITUTE

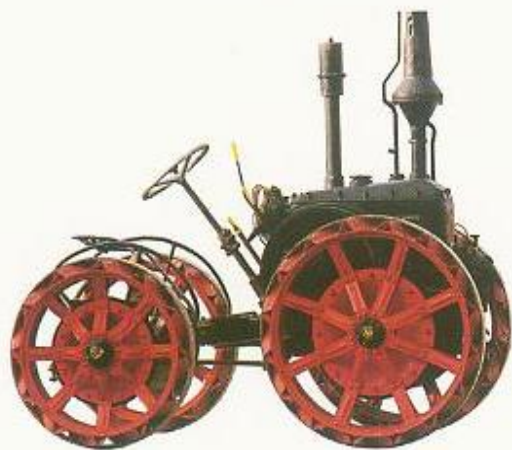

ACTUAL TASKS ON AGRICULTURAL ENGINEERING



PROCEEDINGS OF THE
30. INTERNATIONAL SYMPOSIUM ON
AGRICULTURAL ENGINEERING

OPATIJA, CROATIA, 12. – 15. March 2002.

AGRONOMSKI FAKULTET SVEUČILIŠTA U ZAGREBU
ZAVOD ZA MEHANIZACIJU POLJOPRIVREDE
POLJOPRIVREDNI FAKULTET SVEUČILIŠTA U OSIJEKU
FAKULTETA ZA KMETIJSTVO UNIVERZE V MARIBORU
KMETIJSKI INŠTITUT SLOVENIJE
HRVATSKO AGRONOMSKO DRUŠTVO
HRVATSKA UDRUGA ZA POLJOPRIVREDNU TEHNIKU
HRVATSKI ZAVOD ZA POLJOPRIVREDNU SAVJETODAVNU SLUŽBU



AKTUALNI ZADACI MEHANIZACIJE POLJOPRIVREDE

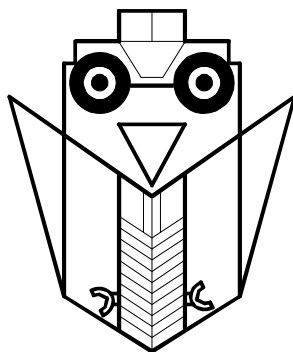

ZBORNİK RADOVA

30. MEĐUNARODNOG SIMPOZIJA IZ PODRUČJA
MEHANIZACIJE POLJOPRIVREDE

OPATIJA, 12. – 15. ožujka 2002.

Izdavači Published by	Zavod za mehanizaciju poljoprivrede, Agronomski fakultet Sveučilišta u Zagrebu, Svetošimunska 25, 10000 Zagreb HINUS, Miramarska 13 b, Zagreb
Glavni i odgovorni urednik Chief editor	Silvio Košutić e-mail: skosutic@agr.hr
Tehnički urednik Technical editor	Hrvoje Zrnčić
Organizacijski odbor Organising committee	Dubravko Filipović, Đuro Banaj, Dušan Brkić, Krešimir Čopec, Zlatko Gospodarić, Viktor Jejčić, Ivo Juras, Igor Kovačev, Miran Lakota, Tomaž Poje, Robert Zimmer
Znanstveni odbor Scientific committee	Silvio Košutić, Rudolf Emert (Croatia), Hermann Auernhammer, Siegfried Kleisinger, Karl-Theodor Renius (Germany), Daniele De Wrachien, Ettore Gasparetto (Italy), Akira Oida (Japan), Linus U. Opara (New Zealand), Maohua Wang (P.R. China), Jaime Ortiz- Canavate (Spain), Vilas M. Salokhe (Thailand)
Tisak Printed by	KRATIS, Zagreb, Hrvatska
Naklada Number of copies	300

ISSN 133-2651

http://www.agr.hr/aed_syposium.htm

Radovi iz Zbornika su od 1997. indeksirani u bazama podataka:
Papers from the proceedings have been indexed since 1997 into databases:

Current Contents Proceedings, ISI - Index to Scientific & Technical Proceedings, CAB
International - Agricultural Engineering Abstracts, Cambridge Scientific Abstracts -
Conference Papers Index, InterDok.

SPONZORI – SPONSORS

**MINISTARSTVO ZNANOSTI I TEHNOLOGIJE
REPUBLIKE HRVATSKE**

**INA
ZAGREB**

**AGROGROM
SAMOBOR**

**STEP&CO
VELIKA GORICA**

**NOVOCOMMERCE
OSIJEK**

**SIP
ŠEMPETER, SLOVENIJA**

**OPRUGA
DEŽANOVAC**

**VOGEL&NOOT
WARTBERG, AUSTRIJA**

**POLJOOPSKRBA KOMPLEKSNA MEHANIZACIJA
ZAGREB**

**AGROMEHANIKA
KRANJ, SLOVENIJA**

**GRAMIP TPS
DUBRAVA**

**AGROMARKETING
ZAGREB**

PREDGOVOR

Profesori poljoprivrednog strojarstva s Poljoprivrednog fakulteta Sveučilišta u Zagrebu i mehanizatori poljoprivrede Hrvatske organizirali su 1970. godine prvi međunarodni simpozij “Aktualni problemi mehanizacije poljoprivrede”. Začeta je time tradicija okupljanja znanstvenika, stručnjaka, stručnih trgovaca, mehanizatora praktičara i onih poljoprivrednika koji uočavaju da tehnika najviše mijenja svijet. Rođen je svijet mehanizatora Hrvatske raspoložen za suradnju. Na svim simpozijima pod istim nazivom, a 1984. preimenovanim u “Aktualni zadaci ...” sudjelovao je s radovima primjeren broj znanstvenika iz zemalja današnje Europske Unije. Znanstvenici s radovima i stručni sudionici, bili su brojni kolege iz Bosne i Hercegovine, Crne Gore, Kosova, Makedonije, Slovenije, Srbije i Vojvodine.

Organizacija simpozija zahtjevan je posao. Odabirom tematike i animiranjem autora članaka to započinje. Prelazi u trajnu komunikaciju s autorima, odabir članaka, izbor recenzenata, nadzor kvalitete tiskanog materijala, osiguranje novca za tiskanje zbornika, organizaciju skupa, da bi sve to rezultiralo uspješnom razmjenom znanja i ideja u živoj i dinamičnoj raspravi. Unatoč naporu simpozij je održan tijekom svih proteklih trideset godina. Komu to zahvaliti? Osim autorima članaka, organizatorima i sponzorima zasluga pripada prije svega kolegama mehanizatorima koji su, usprkos raznim teškoćama, našli sredstava, interesa i želje za sudjelovanjem.

Jubilarni trideseti simpozij odvija se pod pokroviteljstvom Europskog Društva za Poljoprivrednu Tehniku (EurAgEng), Međunarodnog Društva za Poljoprivrednu Tehniku (CIGR), Azijskog Društva za Poljoprivrednu Tehniku (AAAE) i Američkog Društva za Poljoprivrednu Tehniku (ASAE), čime je potvrđena sveukupna kvaliteta simpozija i rezultati ustrajnog i dugotrajnog rada. Radovi iz posljednjih pet Zbornika radova simpozija uvršteni su u baze podataka ISI: Current Contents Proceedings i ISTP (Index to Scientific & Technical Proceedings), Instituta za znanstveno informiranje (ISI). Ovaj jubilarni Zbornik donosi 42 rada, čiji autori dolaze iz Estonije (1), Hrvatske (9), Irana (1), Italije (3), Japana (1), Litve (1), N.R. Kine (2), Nizozemske (1), Novog Zelanda (2), Njemačke (4), Rumunjske (2), Ruske Federacije (2), Slovačke (1), Slovenije (10), Španjolske (1) i Tajlanda (1). Nadamo se da će ovaj jubilarni simpozij pružiti svim sudionicima interesantne i korisne spoznaje, nove kontakte, te prije svega ugodno druženje.

Glavni Urednik

Dr. Silvio Košutić

Zagreb, siječanj 2002.

PREFACE

Agricultural engineering Professors at Faculty of Agriculture, University of Zagreb with agricultural engineering experts allround the Croatia organised in 1970.,the first international symposium “Actual Problems in Agricultural Engineering”. That was the moment when tradition of annual gathering of scientists, experts, agricultural engineers, merchants and farmers all of them who realised that technique has changed our world, began. At previous symposiums, in 1984 renamed into “Actual Tasks on Agricultural Engineering”, significant number of foreign authors mostly from nowadays EU countries, participated.

The symposium organisation is pretty demanding job. It starts with choosing and animation of authors, then continues with frequent contacts, paper selection, reviewers selection, checking the quality of printed materials, assuring enough money for proceedings printing and it ends with closing ceremony. In spite of all mentioned demands and hard labour, symposium has been organised during the all past thirty years. Whom we have to be thankful? Except paper authors, organisers and sponsors, thankfulness must be expressed to our colleagues, agricultural engineers who in spite of all difficulties, have found interest, willingless and money to attend symposium during all these years.

The 30th symposium is cosponsored by European Society of Agricultural Engineers (EurAgEng), International Commission of Agricultural Engineering (CIGR), Asian Association of Agricultural Engineering (AAAE) and American Society of Agricultural Engineering (ASAE), which has proved overall symposium’s quality level and also results of persistant and well aimed organiser’s work. The five previous proceedings were included into the following ISI’s databases: Current Contents Proceedings and Index to Scientific&Technical Proceedings (ISTP). This jubilant proceedings contains 42 papers from following countries: Croatia (9), Estonia (1), Germany (4), Iran (1), Italy (3), Japan (1), Lithuania (1), The Netherlands (1), New Zealand (2), P.R. China (2), Romania (2), Russian Federation (2), Slovakia (1), Slovenia (10), Spain (1) and Thailand (1). We hope that the jubilant symposium will assure all the participants interesting and useful information, new contacts and above all pleasant time.

Chief Editor

Dr. Silvio Košutić

Zagreb, January 2002.

SADRŽAJ – CONTENTS

J. Ortiz-Cañavate	11
Zaštita okoliša primjenom prikladnih tehnologija u poljoprivredi <i>Defense of the environment by using appropriate technologies in agriculture</i>	
E. Gasparetto	23
Razvoj europske standardizacije: sigurnost rada s poljoprivrednim strojevima <i>Development of the European standardisation on agricultural machinery safety</i>	
L. Opara	33
Edukacija i istraživanja u području poljoprivredne tehnike u ekonomiji temeljenoj na znanju <i>Agricultural engineering education and research in knowledge-based economy</i>	
M. Čuljat	47
Dobra stručna praksa <i>Appropriate expert practice</i>	
M. Lakota, D. Stajniko	53
Preciznost različitih GPS sustava u Sloveniji <i>Precision of different GPS systems in Slovenia</i>	
M. Dolenšek	61
Strojni prsteni u Sloveniji <i>Machinery rings in Slovenia</i>	
K. Tamm	67
Optimizacija radnog vremena strojeva na gospodarstvima-proizvođačima žitarica <i>Optimisation of a cereal growing farm's machinery operating time</i>	
R. Bernik	77
Kvaliteta i upotreba poljoprivredno tehničkog zakonodavstva u Sloveniji <i>State and implementation of agricultural legislation in Slovenia</i>	
K.T. Renius	87
Globalni razvoj traktora: proizvodne familije i tehnološke razine <i>Global tractor development: product families and technology levels</i>	
D. Kraljević, R. Emert, T. Jurić	97
Karakteristike diesel motora primjenom diesel i biodiesel goriva <i>Diagnosis of the characteristic of a diesel engine using diesel and biodiesel fuel</i>	

V. Jejić, A. Štern, T. Poje, I. Kovačev, K. Čopac	103
Razvoj mjerne opreme za ispitivanje traktora AGT 835 <i>Development of measuring equipment for tractor AGT 835</i>	
A. Štern.....	113
Vučne karakteristike traktora AGT 835H Drawbar performance of tractor AGT 835H	
A. Oida	121
Razvoj električnog poljoprivrednog vozila upravljanoj mikro valovima <i>An attempt to develop an electric agricultural vehicle by the microwave power transmission</i>	
J. Semetko, I. Janosko, P. Pernis.....	129
Raspodjela zakretnog momenta i vučne sile na kotače traktora i pogonske prikolice <i>Distribution of driving moments and pulls on tractor and semi-trailer wheels</i>	
V. Schlotter	137
Mjerenje i modeliranje interakcije pneumatik-tlo na kompaktnoj i rahloj podlozi <i>Measurement and modelling of the tyre-soil interaction of agricultural tyres on firm and yielding ground</i>	
V.M. Salokhe, I. Hidayat.....	153
Sustav upozoravanja granične stabilnosti za male dvoosovinske traktore <i>A stability alarm system for small four-wheel tractors</i>	
V. Goglia, Z. Gospodarić	163
Vibracije prenesene s volana traktora LPKT 40 na ruke vozača <i>Tractor LPKT 40 driver's exposure to hand-transmitted vibration from the steering wheel</i>	
H.N. van Lier, D. De Wrachien	171
Planirano korištenje tla: ključ održivog razvoja <i>Land use planning: a key to sustainable development</i>	
Y. Sun, M. Wang	185
Modeliranje i eksperimentalni pristup izrade sonde za mjerenje vode u tlu <i>A modeling and its experimental approach for the impedance of multi-pin soil probes</i>	
R. Zimmer, Z. Milaković, B. Miloš, Ž. Kržek, M. Bračun, S. Zuzjak, J. Ipša, M. Šeput .	197
Načini obrade tla i sjetva ratarskih kultura u Slavoniji i Baranji <i>Soil tillage and arable crops sowing practice in Slavonia and Baranja</i>	
S. Košutić, D. Filipović, S. Husnjak, Đ. Banaj, M. Bračun	211
Proizvodnja kukuruza različitim načinima obrade tla <i>Maize production by different soil tillage systems</i>	
T. Ioan	217
Ispitivanje pluga premetnjaka s traktorima različite snage u rumunjskim uvjetima <i>The researches concerning the experimentation of the ploughs reversibles in the aggregate by the tractors of 65 – 110 HP</i>	

T. Ioan	223
Ispitivanje zvrk drljače s traktorima različite snage u rumunjskim uvjetima <i>The researches concerning the experimentation of the harrowes with vertical rotors in aggregate by the tractors of 65 – 110 HP in the working conditions from Romania</i>	
D. Ehlert, K.H. Dammer, U. Voelker	231
Mehaničko-elektronički senzor utvrđivanja sklopa strnih usjeva <i>Pendulum-meter for site specific farming</i>	
H. Hesse, G. Keuper	241
Nadzor i upravljanje protoka mase hidraulički pogonjenih centrifugalnih rasipača mineralnog gnojiva <i>Massflow-control on hydraulically driven disc-spreaders</i>	
T. Ploj, B. Muršec	249
Usporedba radnih karakteristika centrifugalnog rasipača mineralnog gnojiva i rasipača s oscilirajućom cijevi <i>Comparison of spinning disc and oscillating spout fertilizer spreaders performance</i>	
G. Litchman, V. Drintcha	261
Variranje doze mineralnog gnojiva korištenjem optimizacije <i>Variable rate of mineral fertilizers application optimization</i>	
V. Drintcha, S.A. Pavlov	265
Povećanje učinkovitosti odvajanja sjemena u gravitacijskom separatoru <i>Increase of efficiency of seed separation in gravity separator</i>	
Z. Menalo, L. Šumanovac, D. Brkić, T. Jurić, M. Jurišić, D. Knežević	275
Racionalizacija broja kombajna na području sirovinske službe “Sladorane” Županja <i>Rationalization of combine number in the area of raw material section of “Sladorana P.L.C. Županja”</i>	
R. Šimunić, J. Ipša, R. Zimmer, I. Martinić	281
Spremanje sjenaže i silaže kombajnom Claas Jaguar 860 <i>Haylage and silage storing by Claas Jaguar 860</i>	
B. Šket, M. Šket	289
Stanje aparata za zaštitu bilja nakon provjere 2000. i 2001. godine i najčešći kvarovi <i>Review of plant protection equipment condition and the most frequent failures after compulsory checking in the year 2000 and 2001</i>	
L. Pari, M. Cutini	297
Energija iz biomase u poljoprivredi Italije: najnovija dostignuća <i>Energy from biomass in Italian agriculture: state of the art</i>	
L. Pari, M. Cutini	309
Prvo ispitivanje strojeva za sakupljanje i usitnjavanje orezanih grana u voćnjaku, vinogradu i masliniku <i>First test on pruning harvesting</i>	

T. Poje	317
Eksploatacijske karakteristike sitilice otpadnog drva Chromcom <i>Exploitation characteristics of Chromcom wood chipping machine</i>	
S. Sito, J. Barčić, G. Fabijanić	325
Problematika održavanja plodnosti tla u voćnjaku <i>Problem of maintenance of soil fertility in orchard</i>	
D. Stajanko, M. Lakota	333
Primjena blob analize slike za praćenje rasta i razvoja plodova jabuka sorte "Gala" <i>The implementation of blob analysis for predicting the development and yield of apple variety "Gala"</i>	
Q. Zou, L. Opara	343
Simulacijski softver protoka zraka i prijenosa topline u ventiliranim sustavima pakiranja voća <i>Cool-simu: a CFD software for simulating airflow and heat transfer processes in ventilated packaging systems</i>	
J. Khazaei, A.M. Borghei, M. Rasekh, H. Rabani	353
Fizičko –mehanička svojstva ljuske i jezgre badema koja utječu na drobljenje i ljuštenje <i>Physical and mechanical properties of almond and its related to cracking and peeling</i>	
F. Vučajnk, T. Godeša	367
Utjecaj rada nagrača na kvalitetu nagrtanja i urod krumpira <i>Influence of three different ridgers on yield of potato and ridge qualities</i>	
S. Ivančan, S. Sito, G. Fabijanić	377
Oštećenje sjemena povrća pri različitim brzinama sjetve <i>Seed damage at various drill speeds</i>	
M. Li, M. Ohura	383
Sustav nadzora životnih uvjeta u proizvodnji dudovog prelca u realnom vremenu <i>Real-time monitoring system of rearing conditions for silkworm production</i>	
B. Kavolelis	391
Temperaturni uvjeti u neizoliranim stajama za krave <i>The temperature conditions in uninsulated cowshed</i>	



DEFENSE OF THE ENVIRONMENT BY USING APPROPRIATE TECHNOLOGIES IN AGRICULTURE

JAIME ORTIZ-CAÑAVATE

Polytechnic University of Madrid
Madrid, Spain

SUMMARY

The correct application of tractors and agricultural machines are analysed with the goal of eliminating possible damages to the soil, the cultures, the animals, the people and the environment. In relation to tractors some points are considered: the use of biofuels to reduce the greenhouse effect in the atmosphere, the methods to avoid damages of compaction of the land and the systems of protection to the worker. The use of implements and agricultural machines should be made without causing damages to the soil by erosion, without contaminating the waters (e.g. by excess of fertilizers), or the environment (e.g. by a bad application of pesticides) and without being the cause of accidents to the workers who manage them. With regard to this point, some general norms of security and prevention of accidents in the use of agricultural machines and with regard to the defence of the environment (taking into account some guidelines of the Common Agricultural Policy of the European Union) are given.

Key words: *environmental protection, agriculture, appropriate technology*

INTRODUCTION

The relationship between Humanity and Environment is fundamentally utilitarian, since the man through his different economic activities has obligatorily to affect Nature. Until the beginning of the XX century the human incidence on the environment had been very small. However in the last decades the man's action on the biosphere has been more and more active and aggressive, alterations that put in danger the survival of multiple species including the human one. It seems that a conflict is settled down between progress and environment; however it could be balanced if the best in both tendencies are put together with the application of the theory of *sustainable development*.

The Agriculture can be a source of environmental contamination if appropriate technologies are not applied, and this is the objective of this conference: to analyse those appropriate agricultural technologies that can be considered of minimum disturbance with the rural environment.

When referring to agricultural technologies, we will make mention especially to machinery of minimum disturbance (tractors with special rolling systems for minimum compaction of the land, conservation tillage, sludge treatments, suction machines against insects, machines for arboreal treatments with recovery of the product, etc); for security and prevention of accidents; of renewable energy (solar energy for drying, wind energy, biofuels) and management of agricultural and livestock wastes; to the systems of purification of residuals and lastly we will make a synthesis of the European environmental politics's guidelines in the agrarian environment.

Environmental impact of a project is defined as the difference between the evolution of the environmental system "with" and "without" the project, in terms of health and human comfort. Sometimes, the spontaneous evolution of the system is negative, so this negative environmental impact happens if no action is carried out. It is the case of many rural areas with active erosion processes; another important case is depopulation process, with lost of ecosystems, landscapes, buildings and cultural patrimony, that can only survive with the active presence of local people. In these circumstances, the absence of human action can be considered as a true negative impact, with responsibilities for the government and professionals involved.

Agricultural systems are different from the natural ecosystems, since they are much more simple. Then, the first effect of the use of natural areas for agriculture is the simplification of the bio-structure. If this process is slow, the species can have enough time to adapt themselves to the new situation, and the new system can maintain a certain complexity. The problem is bigger when the change is sudden or the area has scarce resources. This type of problem often happens in forests, everglades and humid grounds, transformed into crop fields with doubtful economical results.

TRACTORS WELL UTILISED

A first aspect that we should consider in the use of tractors is that their engines shouldn't contaminate, or if they do it, they should affect the environment with the smallest incidence. For that reason it should be a strict *control of the emissions* of the engines of tractors and agricultural machines to reduce the percentage of carbon monoxide (CO), hydrocarbons without burning (HC), nitrogen oxides (NOx) and oxygen sulphide (SO₂) that are in greater or smaller proportion in the exhaust gases. Even the carbonic anhydride (CO₂), -that is not considered a pollutant for being in the atmosphere in a natural form (in a 0,03% approximately in volume)-, is being tried to reduce its emissions and its effect in the global heating of the planet. In accordance with a report of the Commission of the UE (1996) the emissions of CO₂ to the atmosphere at world level have evolved in the following way (in millions of tons): 577,53 (1986), 672,91 (1990) and 797,69 (1995), foreseeing to reach 0,04% of CO₂ for the year 2010. To invert the process or at least to try to stop it, the Protocol of Kyoto pretends to increase the biofuels consumption, since their combustion

doesn't produce increase of CO₂, and to reduce the consumption of fossil fuels (petroleum) that produce a net increment of CO₂.

Another possible negative aspect of the use of tractors and agricultural machines is the *compaction* of the land that can destroy the structure of the soil under adverse conditions originating a sole that impedes the development of the plants roots. In the conventional tractors it is possible to fight against compaction using wide radial tires with reduced pressure of the order of 0.5 – 0.7 bar, and even twin wheels in both axes in the case of tractors with double traction. New solutions have arisen for the rolling of tractors in order to reduce to the maximum the compaction of the soil, like the tractors with rubber caterpillars and those of a frame with a great width called "gantry".

These "gantry" machines have appeared recently in the market in the United Kingdom, from an original idea developed in the Silsoe Research Institute of Rural Engineering. The frame (12 to 24 m) is supported over two parts: the first one is the motor equipment (67 kW) and the cabin; the second one has a tank of 2.000 l for treatments. Both structures are supported by two wheels, one behind the other, moving over concrete lines.

We also have to consider the *ergonomics and security* in the work of tractors that are fundamental to reduce possible damages to the workers and the environment. The soil on which the tractors move, offers in many occasions very little stability with important slopes, obstacles (potholes, stones, etc.), which can cause a serious accident or even be mortal in case that the tractor is not provided with a frame or a security cabin. The cabin should be resistant in the event of overturn, but at the same time it should allow an access easy and comfortable to the driver, and be isolated to reduce the noise and the dust. Recently there have been introduced cabins with air condition systems with special filters, called "Spray Ready" that isolate the worker of noxious chemical products from phytosanitary treatments. The noise produced by the tractors engine should not only be reduced in the driver's ear but rather it should also be below a certain value in its environment. The European Directive CE 74/151 establishes the limit admitted at 7,5 m of distance of the tractor: 85 dB(A).

CONSERVATION TILLAGE

Soil tillage has the aim of increasing yield, but usually it pays small attention to the consequences in the own soil. Normally the tillage machinery is evaluated in terms of efficiency, perfection of the labour and costs, but not in terms of its environmental effect. One main problem is *soil erosion*. The awareness of this problem started in the 40's, with intense research on "conservation tillage" in EEUU (Faulkner, 1945). Presently, more than 28 million hectares of crop are grown, in that country, with the mentioned system.

Conservation tillage, as it has been defined by Schert (1988), is a production system in which at least 30 % of the ground area remains covered by inert vegetal waste after sowing. This technique implies the substitution of conventional tillage by herbicides, normally in post-emergence. With this method it is possible to control weeds and maintain the soil protected against erosion.

We are going to describe the two main modalities of "conservation tillage" that are: minimum tillage and direct sowing:

In the *minimum tillage*, deep labour (plough) is substituted by shallow vertical tillage, such as cultivator or chisel, which introduces the vegetal waste of the previous year partially into the ground. Herbicides must be applied to control weeds. Afterwards, sowing is carried out. These labours can be done in one, two or three passes on each field, or it is possible to group the operations with a combination of machines. Minimum tillage is very useful in light soils that tend to compact; in these soils the humidity of the soil is adequate for tillage only in short periods of time. For this reason, the reduction in the number of labours is positive, since they can be carried out easily with the adequate water content to achieve the desired soil tilt.

Direct sowing consists in sowing a crop on the vegetal waste of the previous crop, using special types of sowing machines. These machines are different from the conventional ones, since they have devices to open and close the furrow, and to separate the vegetal waste in the surface. This is the better system for soil protection, since it maintains always a layer of vegetal waste on the soil. Tillage is substituted by the application of herbicides to control weeds. The disadvantage of the method is that it needs special sowing machines, with higher weight, to penetrate in the soil covered by waste. The rest of devices of these machines are similar to the conventional ones. Direct sowing is more appropriate for heavy soils.

The equipment used for conservation tillage is following:

Chisel: it is a tillage equipment which tools are pointed iron bars, mounted on flexible arms ("chisel") or rigid arms ("ripper"). It works breaking the soil, producing big cracks and small particles of soil, without inversion of layers and without ploughpan. In fact, this equipment is one hybrid between the cultivator and the subsoiler, working at intermediate depth. It can work even with a great deal of waste on the ground, producing a moderate effect of burying (30-40 % of the waste in the surface).

Other advantages of the chisel are:

- Higher capability of work than the conventional ploughs, because of higher length of the machine and a work speed up to 10 km/hour.
- For the same volume of removed soil, it requires 40 % less energy than the conventional ploughs.
- Greater versatility to change pointed bars of different types and to change the distance between arms.
- Better adaptation to fields with stones.
- Better possibility of adaptation to combination of machines.

Cultivator: there are many types of cultivators depending on the type of share used, but the most usual in conservation tillage are those "cultivator with wing shares". Their function is to cut the roots of the weeds, spraying the vegetal waste on the ground surface with a minimal alteration of the soil. They do not need a great traction power since the labour is superficial. The tool is a share with shape of "V", in which the separation between the sides of the wings can be of 0,4 m for small machines and 1 to 1,6 m for big machines. The work depth is around 10 cm and the speed is between 6 and 9 km/hour.

Rod-weeder: this type or bar of square section, from 2 to 3 cm of side, is placed in the back of a cultivator, eliminating efficiently weeds, and at the same time making loose the soil. These revolving bars, operating under the soil at a depth of 8 to 12 cm, rotate in the opposite sense to the tractor wheels, at 100 to 150 r/min in machines activated from the tractor power take off (PTO). There are other types of revolving bars, activated from the wheels that rotate at slower speeds.

Direct sowing machines: they are heavier machines than the conventional ones, with tools to open and close the sowing furrows in non-laboured fields, and with other elements to separate vegetal waste.

Direct sowing machines have following characteristics:

- Strong and heavy enough to cut the waste and let the seeds in every type of soil.
- Able of opening small furrows of 5 to 12 cm depth (in function of the conditions of the soil) and 5 to 8 cm wide, where the seeds are placed.
- With tools to cover the seeds and to compact the soil in the furrow to get a good contact between seeds and soil.

MACHINERY OF MINIMUM ENVIRONMENTAL IMPACT

Inside this section we will include some types of machines or systems designed with the high-priority objective of defence of the rural environment, like:

- The tanks for *slurry distribution* pretend to distribute the slurries in the soil, burying them in certain conditions, to avoid nutrient losses and bad smells. These tanks, -that are used in all Europe and especially in Germany and Holland-, are equipped with hoses that distribute the slurries over the soil, or bury the product using additional injector pointed tines. The precision of the distribution is maximum, so it is possible to carry out the operation even with crop, without danger for the plants. During operation, the emissions of NH_4 and odour are minimum. When burying the product, slurries are impelled by a pump through the injector tines, placed in the back of the tank, at a depth of 15 to 20 cm, localising the product in the soil. The system is especially suitable for prairies. Because of its higher price with respect to the conventional tanks, it seems more adequate for cooperatives or renting.
- Rationalization of the *use of fertilizers*, the modern agriculture requires the use of important quantities of fertilizers; frequently the fertilization is carried out in a not very technical way, without an appropriate knowledge of the conditions of the soil and of the laws that govern the nutrition of the vegetables and, if the distribution is made with wrong doses or bad uniformity, there will be differences in yield between sectors or even a decrease of yield. Therefore it is necessary to use good equipment and to employ it adequately. Recently it is spread to carry out fertilizing maps for each parcel by means of the localization of the machines for satellites (GPS), being established in function of the production obtained in previous crops.

The problem is similar in the *application of pesticides*. In this case techniques have changed strongly in the last years; losses of product are avoided, and in some equipment

doses are very low (ultra low volume applications). With suitable doses, and good uniformity, it is sure that the influence on people, animals, crop and environment is minimum; in any case, using low doses, the environment will be able of filtering the residues. In exchange, the wrong application can be quite negative, specially when using concentrate products, because of the problems in the elimination of the residues. The electronic advances are cooperating in the improvement of this type of technologies.

The equipment for *treatments with recycling of the product* are mounted on motorised frames; they move over the line of fruit trees or vineyards, with special screens in both sides of the hedgerow in front of the sprayers, and trays under the system to recover the product that falls from branches and leaves. This liquid is filtered and sent back to the tank to be reused. This method represents a great advance to reduce the drift under adverse atmospheric conditions.

The equipments for *insect suction* are beginning to be used in strawberry (California) and potato (Central Europe) cultures to fight pests of different insects (scarabs, aphids, larvae, etc.). This type of equipment, working by the suction principle, is mounted in front of the tractor, suctioning the insects and destroying them in the rotating fans.

SECURITY AND PREVENTION OF ACCIDENTS

As for the teams of the worker's protection and prevention of accidents in the agricultural machinery, it is spoken recently (Sarig, Y. 2000) of a new concept like it is the *ethics* in the construction and in the application of the machinery, what supposes a special attention to the worker that manages it. Also inside this same concept a great importance is given to the personnel's continuous education to adapt themselves to the new technologies (Scotti, A. 2000). Next some general norms of security and prevention of accidents in the use of agricultural machines are given (Ortiz-Cañavate, 1995):

General safety and accident preventive advice

- Pay attention to the effective general dispositions on security and protection to the worker.
- The signs of attention and of warning attached in the machines provide important information for safe operation. Their observation is important for its security!
- Observe the appropriate regulations when taking the machine onto public roads!
- Become acquainted with all installations and controlling devices as well as with their function before beginning with the operation. Doing this during operation would be too late!
- The clothing of the operator should fit well. Avoid wearing any loose clothing!
- Keep the implement clean to avoid the risk of fire!
- Before starting or driving the implement, be sure that there are no persons in the immediate vicinity (especially children). Ensure that you have sufficient visibility!
- No persons other than the operator may ride on the machine during the work; the machine may not be used to transport goods or people!

- Couple the machines in accordance with regulations and only secure it to the prescribed device!
- Particular attention must be paid when coupling and uncoupling the machines to and from the tractor!
- When assembling and disassembling, ensure that the support devices are positioned correctly (stability).
- Fit counter-weights always as advised to the fixing points provided for that purpose on the tractor!
- Adhere to the maximum permissible axle loads, total weights and transport measurements!
- Observe the national traffic regulations with regards to transport dimensions!
- Fit and check transport gear, traffic lights, warnings and guards!
- The release ropes for quick coupler must hang freely and in the lowered position must not release by themselves!
- During driving, never leave the driver's seat!
- Travelling behaviour, steerability and braking effectiveness are influenced by integrated and attached devices and ballast weights. Therefore, ensure that the machine has adequate steering and braking effectiveness!
- When lifting the implement with the rear hydraulics the front axle load of the tractor is reduced. The sufficient front axle load (20% of the tractor's net weight) has to be observed. (Please adhere to the instruction manual of the tractor's manufacturer.)
- When driving on curves, take the width and/or the balance weight of the machine into account.
- Only put machine to operation with all guards fitted properly!
- Loading of the machine is only permitted with stopped engine, removed ignition key and applied parking brake.
- Do not stand in the turning and swivelling clearance area of the machine!
- To avoid injury, keep clear of all parts actuated by external power (e.g. hydraulically).
- Before leaving the tractor lower the machine to the ground. Stop engine and remove ignition key!
- No persons must stand between the tractor and the implement unless the handbrake and/or chocks have been applied to prevent the vehicle from rolling. The engine has to be stopped and the ignition key removed.

General safety and accident preventive advice for implements mounted to the tractor's three-point hydraulics

1. Before mounting and dismounting implements to the tree-point hydraulics bring all control levels in such a position that an unintended lifting or lowering is impossible!

2. When fitting to the tree-point linkage the mounting categories on the tractor and the implement must coincide!
3. Within the range of the tree-point linkage danger of bruising and shearing!
4. When actuating the control levers for the tree-point linkage never step between tractor and implement!
5. In transport position always take care for a sufficient lateral locking of the tractor's three-point!
6. For road transport with lifted implement the control level has to be locked against unintended lowering!
7. Mount and dismount implements as prescribed. Check braking systems for function. Mind manufacturer advice!
8. Working implements should only be transported and driven on tractors, which are designed to do this!

General safety and accident preventive advice for PTO shaft drive

1. Only use pto shafts recommended by the manufacturer!
2. Guard tubes and cones of the pto shaft as well as a tractor and machine pto guard must be fitted and kept in a correct place
3. Note the prescribed pto-shaft tube guards in transport and operating position!
4. Mounting and dismounting PTO-shaft only with disengaged PTO-shaft, stopped motor and removed ignition key!
5. Always care for correct fitting and securing of the PTO-shaft!
6. Prevent pto guard from spinning by fixing the provided chains!
7. Before engaging the pto shaft ensure that the chosen PTO-speed of the tractor corresponds to the allowable implement input speed!
8. When using the ground speed related PTO-shaft note that the speed is related to the forward speed and that the sense of rotation reverses when backing up!
9. Before switching on the PTO-shaft nobody is allowed to stay in the area of the spinning PTO-shaft!
10. Never switch on the PTO-shaft while the engine is stopped!
11. When operating with the PTO-shaft nobody is allowed to stay in the area of the spinning PTO or universal joint shaft!
12. Always switch off PTO shaft when it forms excessive angles or not needed!
13. Attention! After switching off the pto shaft the mounted implement may still continue to run by its dynamic masses! During the period never come too close to the implement. Begin work only after the implement has come to a full standstill!
14. Clean and grease the universal joint shaft and the PTO-driven implement only after the PTO-shaft and engine have been stopped and the ignition key removed!

15. Deposit removed PTO-shaft on the provided carrier!

General safety and accident preventive advice when making use of a hydraulic system

1. The hydraulic system is under high pressure!
2. When connecting hydraulic rams and engines the prescribed connection of the hydraulic hoses has to be noted!
3. When connecting the hydraulic hoses to the tractor's hydraulic take care that the hydraulic is pressureless as well on the tractor-as on the implement side!
4. At hydraulic function connections between tractor and implement, the sockets and plugs should be colour coded in order to avoid wrong operation.
5. When mixing up connection, danger or reverse function, e.g. lifting instead of lowering. Danger of accident!
6. Regularly check hydraulics hoses and exchange in case of damages or aging. The replacement hoses have to correspond to the technical demands of the implement manufacturer!
7. When searching for leaks appropriate aids should be used due to danger of injury!
8. Liquids (hydraulic oil) penetrating under high pressure may penetrate the skin and cause several injuries.
9. In case of injuries immediately see a doctor. Danger of infection!
10. Before starting to do any repair work on the hydraulic system, lower implement, relieve system from pressure and switch off the engine!
11. The period of use of any hose circuit should not exceed six years including a possible storing of two years in maximum. Also when stored and used properly, hoses and hose circuits age. Therefore, their longevity and period of use is limited. Deviations from the above may be accepted depending on the experience made and the danger potential. For hoses and hose circuits made of thermoplasts other guidelines may prevail.

General safety and accident preventive advice for maintenance, repair and cleaning

1. Repair, maintenance and clearing operations as well as remedy of function faults should principally be conducted with a stopped drive and engine. Remove ignition key!
2. Check nuts and bolts regularly for tightness and retighten if necessary!
3. When doing maintenance works on the lifted implements make sure hat it is secured by proper supports!
4. When changing operating tools with cutting edges use appropriate tools and wear gloves!
5. Dispose of oil, grease and filters in the appropriate manner!
6. Before doing any repair work on the electric disconnect power supply!
7. Before conducting electrical welding operations on tractor or on the mounted implement, remove cable from generator battery!

8. Any spare parts fitted must, in minimum meet with the implement manufacture's fixed technical standards.

RENEWABLE ENERGY

Agricultural production requires the use of energy, additionally of the solar energy used by the photosynthetic activity of the plants. There is a strong relationship between the energy employed per surface unit and the final yield. Sometimes, environment suffers the impact of this energy input through tillage, fertilisers, irrigation, pesticides, etc.

For these reasons, the use of renewable energies is one of the methods that can maintain rural production within a sustainable situation, saving fossil fuel (already scarce) and reducing the pollution.

The *solar energy* that arrives to the earth is of the order of 35 000 times higher than the energy presently used by men. Its mean intensity is 1,36 kW per square meter, measured in a surface perpendicular to its trajectory, when arriving to the atmosphere; this value is called *solar constant*. The atmosphere of the earth absorbs a great part of the solar energy or it is irradiated again to the space. In optimal conditions, the practical values that can be used of solar radiation are 6 to 8 kWh per square meter and day.

There are many types of solar panels to convert the radiation into heat, such as flat panels to heat water at low temperatures (under 100 °C), concentration panels for higher temperatures, and solar panels for air heating. The usual applications in rural areas are in drying of agricultural products (air heating panels) and the production of warm water at about 45 °C (flat panels). Photovoltaic panels convert the radiation into electricity; they are usually used in isolated areas far away of the electrical networks.

The *wind energy* can be considered as a type of solar energy, because the wind is a consequence of the solar radiation. This type of energy is completely clean and it can be profitable in areas where there is wind with a mean intensity above 6 m/s. As for its application in rural areas, wind energy is used in water pumping or generation of electricity in the farm.

Energy from *biomass* is used directly in combustion of wood and other natural products and to produce biofuels, liquids such as ethanol or biodiesel (esters from vegetal oils) or gaseous (biogas or producer gas). The use of biofuels reduces the consumption of fossil fuels and all the problems derived from it.

SYSTEMS OF DEPURATION OF RESIDUES

One of the problems of the livestock farms is the elimination of residues. Since direct pouring to rivers or lakes is not adequate because of the problems of pollution that they cause, the suitable method to get rid of them is the depuration of residues and the pouring of the processed waste to water courses, if this waste accomplishes the conditions established. Presently, these conditions (BOD, QOD, total suspended solids, microbial concentration, Phosphorus and Nitrogen totals, etc.) depend on the use of the water in the river bed affected, being more severe if it is devoted to human consumption.

There are mainly two methods in depuration of residues: aerobic and anaerobic.

Aerobic methods. In the aerobic methods, the agent acting is the oxygen of the air, or when this oxygen comes from photosynthetic algae grown in the liquid mass (non forced aeration).

When great surfaces are required, artificial lakes are used; in exchange, when the surfaces implied are lower, the process is called *forced aeration* and it is necessary to use mechanical elements such as turbines to incorporate oxygen to the water. These methods have lower needs of energy and they achieve a great reduction of solids in the water and of pathogens. The disadvantages are the big needs of surface and the small capacity to reduce the BOD₅.

Anaerobic methods. This method is based in the action of anaerobic bacteria, that transform the pollution waste into methane (CH₄), which can be used as fuel to produce energy. This method of depuration requires anaerobic tanks in which the reactions of the bacteria take place, and the necessary installations to use the biogas. This system is more adequate than the aerobic method for the treatment of liquid livestock residues, since the costs of management are lower, produces energy (instead of consuming it) and allows bigger levels of BOD₅. In exchange, the costs of installation are expensive, and the maintenance must be very careful; it needs specialised personal and strict safety controls.

AS CONCLUSION: THE EUROPEAN ENVIRONMENTAL POLITICS APPLIED TO THE AGRICULTURE

In the European Union there exists a great concern for the environment, like it is shown in its environmental politics and in the establishment of environmental programs. This politics can be summarized in the following sentences:

- Non utilitarian consideration of the Nature to recognize it as the whole mankind's patrimony, which doesn't imply a negation of the economic development, but a control of this to guarantee an ecological balance now and in the future.
- The opposition outlined economy-ecology in an interested way is substituted by integrated focuses in which economy and ecology are not antagonistic concepts but complementary. The real economic orientation is ecological and the ecological is economic: at large the respect to the environment is more economic.
- Orientation of the development towards quality of life and work.
- Principle of prevention avoiding or reducing the undesired effects at the beginning instead of correcting them afterwards: “better to prevent that to cure”.
- Importance of the personnel's continuous formation to adapt them to the new technologies.
- Organisation of the territory based in the available resources and in the ecosystems.
- Careful and rational use of the natural resources since they are limited: it is necessary to know the ecological offer against the economic demand.
- Adoption of the principle: “those who pollute should pay.”

- Internationalisation of the environmental costs in the financial evaluation of the projects.
- Explicit consideration in the projects of synergies and incidences in the human health and in the environment.
- Promotion of clean technologies with minimum impact, soft and adequate. "Ethical" attitude with regard to the environment.
- Use of environmental projects as development actions.
- Search and promotion of projects environmentally positive and economically feasible.
- Evolution of the principle: "those who pollute should pay", towards financial help to the decontamination.
- Integration of the environment politics in the rest of the politics of the European Community.

REFERENCES

1. Central-Hispano, (1997.) "El Campo y el Medio Ambiente - Un futuro en armonía". Capítulo 12 - J. Ortiz-Cañavate "Las máquinas que no hacen daño: el buen uso de las máquinas agrícolas" (pp. 191 - 205) SOPEC Editorial. Madrid. 263 págs.
2. FAULKNER, E. H. (1945.) "La insensatez del agricultor". Editorial El Ateneo. Buenos Aires.
3. GÓMEZ OREA, D. (1991). "Análisis de las actuaciones de la Ingeniería Agronómica en relación con el medio ambiente". Jornadas sobre Ingeniería Agronómica y Medio Ambiente. Madrid.
4. HERNANZ, J. L., (1990.) " Maquinaria para el laboreo mínimo y la siembra directa ". Hojas Divulgadoras del MAPA nº 5/90 HD pp. 36. Madrid.
5. JIMÉNEZ DÍAZ, R. M. Y J. LAMO DE ESPINOSA (1998.) "Agricultura Sostenible". Capítulo 6 - J. Ortiz-Cañavate y J. L. Hernanz "Sistemas de Laboreo" (pp. 119 - 143) Ed. Mundi-Prensa. Madrid. 616 págs.
6. ORTÍZ-CAÑAVATE, J. (1991.) "La Ingeniería agronómica y el medio ambiente". Jornadas sobre Ingeniería Agronómica y Medio Ambiente. Madrid.
7. ORTIZ-CAÑAVATE, J. (1995.) "Normas generales de seguridad y prevención de accidentes", Vida Rural (2), 13: 52-54.
8. SARIG, Y. (2000.) "Ethical aspects in manufacturing agricultural machines". Club of Bologna. 11th Meeting. Tsukuba (Japón) Conferencia patrocinada por UNACOMA (Italia).
9. SCOTTI, A. (2000.) "Ethical aspects of agricultural machinery production". Club of Bologna. 11th Meeting. Tsukuba (Japón) Conferencia patrocinada por UNACOMA (Italia).
10. STOUT, B. (1980.) "Energía para la agricultura mundial". FAO. Roma.



DEVELOPMENT OF THE EUROPEAN STANDARDISATION ON AGRICULTURAL MACHINERY SAFETY

ETTORE GASPARETTO

Istituto di Ingegneria Agraria
Milano, Italy

SUMMARY

Up to the seventies of last century every European country was completely independent from the point of view of safety and ergonomics in agricultural machinery. Some attempts to introduce standards had been performed since the sixties by OECD, but the published codes were not compulsory. The same situation was common to ISO standards.

In 1974 the EU (European Union, at that time EEC) published the first Directive on tractors (74/150/EEC). From that moment all tractors in the EU shall follow the EU directives (now defined "old approach directives"). At the moment the tractor directives are more than 40, of which 23 are independent and the others relative to new developments/ integration/etc. At present they are written in the 11 official languages of the 15 EU members.

In the field of agricultural machinery only the tractor has been examined. The problem was what to do for all other types of agricultural machinery. To solve the question, in 1989 the EU decided to leave the "old approach directives", to introduce the "new approach" ones. These include the Machine Directive 98/37/EC (former 89/392/EEC, etc.) and have large objectives. The same objectives are better determined by specific standards.

The EU and the other western European common market (EFTA, now reduced to Iceland, Norway and Switzerland) charged the CEN (European Standard Commission) to perform this task, publishing the EN standards. The CEN has now 19 members (15 EU, 3 EFTA and the Czech Republic), only 3 official languages (English, French and German) and for the approval of a standard a qualified majority is sufficient.

Activity on agricultural machinery is carried out by the CEN/TC (Technical Committee) 144. The basic work principle is different from the one of EC directives (former EEC). There is no compulsory examination of the machine by

an official organisation. A manufacturer self-certification is sufficient; a seal (CE) on the machine must accompany it together with a declaration of conformity to the Machine Directive.

In 10 years about 30 standards on agricultural machinery have been approved and other 30 are being examined. Following this philosophy the safety and ergonomics principles are common in all CEN countries.

Recently, following the Vienna Agreement between CEN and ISO, a collaboration of the two organisations was decided, in order to avoid work duplication and confrontation. A similar agreement has also been established in the field of agricultural tractors between EU and OECD.

Key words: *standardisation, tractors, agricultural machinery, EU, CEN*

INTRODUCTION

Standardisation began as an activity within advanced industrial groups. Since thousands years bricks are for instance standardised; a journey to the ancient Incas buildings and walls in Peru, all extremely and artistically irregular, may mark the difference. Later standardisation expanded to full national industrial sectors, to countries and finally to the world through the ISO (International Standards Organisation) and IEC (International Electrotechnical Commission).

The road was anyway not so simple. Up to the seventies of last century every European country was completely independent from the point of view of each type of standards, including of course those on safety and ergonomics in agricultural machinery. Some attempts to introduce standards for tractors had been performed since the sixties by OECD (Organisation for the Economic Co-operation and Development), but the published codes were not compulsory. The same situation was common to ISO standards.

In the former western Europe there existed two common markets: the EU (European Union), once known as EEC (European Economic Market) and later as EC (European Community), now with 15 members; the EFTA (European Free Trade Association), at the moment with only 3 countries (Iceland, Norway, Switzerland).

Within these common markets, with the recent addition of the Czech Republic, frontiers have been abolished, for countries recognising the Schengen Treaty, and technical obstruction to the free movement of goods has officially been removed. The recent introduction of the Euro as a common currency for 12 EU members has greatly helped this trend. This also implies the removal of restrictions governing the movement of agricultural machinery through unification of the relative safety and ergonomic standards. With no rules, this implies that a country with a noise limit of 90 dB(A) may freely export its machinery to a second country, where the noise limit is fixed to 85 dB(A); of course the items manufactured in the first country are more dangerous for the ears but cheaper and favoured.

From the point of view of the standards, agricultural machines have been divided into two categories:

- tractors for agricultural and forestry use, which are subject to specific directives;

- all other agricultural and forestry machines, which are integrated in the “Machine” directive and in the CEN (European Standards Committee) standards.

Tractors for agricultural and forestry use have been subject to specific directives since 1974. There are more than 40 directives, which can be reduced to 23 if we exclude those regarding amendments and adaptation to technical development (e.g., the highest speed of the tractors has been increased from 25 to 30 and then to 40 km/h; there exists a proposal for a further increase). Another four directives specifically concern the noise of small garden mowing machines.

In 20 years of activity the former European Community had only partially succeeded in solving the problem of safety and ergonomics for only one of the machines in this sector, i.e. the tractor, while approximately 1000 other types of machines – following an estimation – were left completely untouched by these directives. In addition the same (now defined as “old approach directives”) were limited in their scope and frequent updates were needed to follow the technical progress.

EU and EFTA decided to change their strategy and only issue “general” directives (defined as “new approach directives”) with a large scope and to entrust the prescribing of specific standards to the CEN, a body which was fortuitously created by the same countries. At present the CEN has 19 members (15 EU, 3 EFTA and the Czech Republic). The CEN is more flexible, faster and does not require the unanimous support of all members before reaching a decision. In addition the official languages are only three (English, French and German), while only in the EU they are 11 (thanks to the fact that Austria, Belgium, Ireland and Luxembourg have official languages common to other countries). The CEN standards are named EN (European Standard).

In the area of safety and ergonomics the general “Machinery” directive is the 98/37/EC, which substituted the 89/392/EEC, 91/368/EEC, 93/44/EEC and 93/68/EEC. Of course this directive does not apply only to agricultural and forestry machines, but to all types of machinery, with the exception of a few categories, including for example tractors for agricultural and forestry use.

THE PRESENT STANDARDS

From the point of view of the present European standards situation four organisations shall be examined, following the time of their intervention in the field of agricultural machinery: OECD, ISO, EU and CEN.

The OECD (the former OEEC, Organisation for European Economic Co-operation) approved the first Standard Code for the Official Testing of Agricultural Tractors in 1959. At the moment there exist 8 Codes, two on tractor performance (no. 1 & 2), one on noise (no. 5) and five on ROPS (Roll Over Protective Structures) testing (the others). The success of the codes has continued in spite of the deep crisis which has affected the agricultural machinery industry in the last decade. The OECD member countries are 28, but Australia, Mexico and New Zealand do not take part to the tractor codes; the other countries are the 19 CEN members and Canada, Korea, Japan, Poland, Turkey and USA. Finally China, India and Russia participate to the Tractor Codes, even if not OECD members.

The objective of the OECD codes consists in the reciprocal recognition of the characteristics and tests of a tractor, established under the responsibility of one of the countries participating to the codes. The aim is that standards shall not create obstacles to the international commerce, with the exception of the safety and ergonomics sectors. The success of the OECD tests was so high, that the Nebraska Testing Station gave up to act as an independent body (they tested tractors since the twenties), to become the USA OECD Testing Station.

About 90 national standards institutions are members of the ISO. This organisation aims to promote standards all over the world, to promote goods and service exchange and to develop co-operation in the scientific, technical and economical fields. ISO activity extends throughout all the sectors, with the exception of the electric and electronic ones (competence of the IEC). ISO adopted through its TC (Technical Committee) 23 dozens of standards on ergonomics and safety in the agricultural machinery field.

The problem with ISO is that their safety and ergonomics standards cannot be compulsory. In addition, a big majority of the countries participating in the discussion and approval of the ISO standards are EU and/or CEN members (exceptions are usually Japan and USA). As a result ISO standards are essential and followed in the manufacturing field, where they are not compulsory. On the contrary the ISO standards on safety and ergonomics are practically ignored at international level, where the OECD codes and UE/EN or national standards dominate the situation.

A good question is why international standards organisations, mainly with the same member countries, write different standards for the same subject. The reality is that OECD experts are members of the testing stations, while the ISO ones are primarily manufacturers and standard managers; in addition the EU ones are government people, while during the CEN discussions a mixture of all these representatives is present.

To solve the situation, agreements have been taken:

- the EU has charged the OECD of the modifications to the ROPS standards;
- a Vienna Agreement has been signed between ISO and CEN; as a result, the new safety and ergonomics standards are common and written by the one or the other organisation. They are published as ISO EN standards.

The aim of the “Machinery” directive is to attain a high level of safety, both in design and manufacturing, whilst also allowing for technical innovation. The directive applies to:

- all new machines produced in the EU and EFTA countries;
- all machines, new or used, imported from countries outside the EU and EFTA.

The term “machinery” here defines a group of parts, of which at least one is mobile, which are connected together. An assembly of machines constitutes a machine. The basic principles applied in the drawing up of the Machinery directive are that items of machinery may be used throughout their entire working life without risk, providing they are used correctly, and that when it is impossible to eliminate or reduce the risk, the operator must be informed in an appropriate manner.

Should a member state establish the failure of a certain item of machinery to conform to the Machinery directive, it may call for the machine to be withdrawn from the market or for its distribution and/or use to be limited.

Machinery that are produced in conformance with community directives must be provided with the “EC” mark. There are two categories, in the agricultural machinery sector subject to the directive:

- normal machines;
- PTO shafts and their guards.

For this last item of machinery a compulsory test is necessary. For all machines a declaration of conformity and an instruction book complete with all necessary safety directions must be given to the customer together with the machine itself. In the declaration of conformity the manufacturer, or his representative in the EU or EFTA, states that the machine marketed fully respects all the essential safety requirements relative to the type of machine. To this end the manufacturer must prepare a technical document which shall be available for any eventual control. Among other items, the document must include:

- general and detail drawings of the machine, relative to safety;
- results of tests verifying conformity;
- a list of safety requirements and applied standards;
- descriptions of the solutions employed to prevent risks;
- if required, a technical report or certificate issued by a component authority or laboratory, including the results of any tests performed;
- instructions for the use of the machine, in the language of the manufacturer’s or importer’s country, and, in the case of machines which may be operated by unqualified personnel, in the language of the country where the machine is to be used (of course agricultural machinery falls into this category).

It is superfluous in this context to list all the risks and the measures to be taken to prevent them. However a single example would serve to highlight the completeness and complexity of the Machine directive. The operating instructions to be supplied with each machine must include indications on the level of noise produced by the machine, which means that this noise must be measured and indicated even in the case of extremely quiet machines. In simple terms this means that the manufacturer of a fixed plough without moving parts, for example, will have to specify in the operating instructions that the acoustic pressure level of the plough is less than 70 dB(A).

The Machinery directive is generic and does not take into consideration the risks of the specific types of machines. The CEN is charged of this task, i.e. of writing the relative safety standards. The CEN has about 5000 standards published or under study, though not all of them are connected to ergonomics and safety. The CEN manages about 50 TC (Technical Committees) in the field of machine safety and ergonomics.

One of the CEN TC, the TC 144, is studying the standardisation in the field of safety of machines intended specifically for use in the agricultural and forestry sector. The TC 144 has set up 8 WG (Working Groups):

- WG 1: General requirements;

- WG 2: Tractors and self-propelled machines;
- WG 3: Mobile machines and trailers;
- WG 4: Portable machines and pedestrian controlled machines;
- WG 5: Stationary equipment;
- WG 6: Portable forestry machinery;
- WG 7: Garden equipment;
- WG 8: Forestry machinery.

Among the 30 published standards there are safety standards on:

- General requirements;
- Protection of transmission shafts;
- Combine and forage harvesters;
- Potato and sugar beet harvesters;
- Rotary mowers;
- Sprayers;
- Two types of irrigation machinery;
- Pick-up balers;
- Liquid and solid manure spreaders;
- Trailers;
- Silage cutters;
- Walking tractors with rotary cultivators;
- Etc.

The list is not and cannot be complete and correct. In fact it constantly varies with cancellations and additions. One of the problems is the validity of the EN standards. They are usually recommended, but their weight increases when they are recognised by the EU. A company might not follow them but the safety of its products must conform to alternative standards of at least equal validity.

There are two categories of machines in the Machine directive and EN standards: the normal and the very dangerous machinery listed in the Annex IV of the Machine directive itself. For our sector, there are only the transmission shafts between the tractor and an implement machine and their protections. An official agency/institution shall approve the conformity of these special items, while for normal machinery a self-certification of conformity is sufficient. Practically EU and EFTA adopted the US system: safety requirements are not mandatory, in the sense that the machinery put on the market is not checked, but a very severe check comes later, when and if an accident has occurred.

The manufacturer is completely free in managing its self-certification. He can carry out all the procedures on his own. As an alternative, he can get assistance from outside. The former system is theoretically simpler and certainly more economic, but the manufacturer must know and apply:

- The Machine directive;
- The specific EN standard for the type of machinery he manufacturers;
- The EN standard on agricultural machinery general requirements;
- The EN standards quoted in the two above standards, for example: safety distances; hydraulic and pneumatic circuits; noise and vibrations; etc.;
- The electromagnetic compatibility standard, when electric equipment is mounted on the machine.

A new field of ergonomics in agriculture is the environment. Public opinion is sometime convinced that food may be dangerous for the health, that soil and water are being poisoned by fertilisers and pesticides, etc. As a reaction, so called “biological agriculture” is gaining ground, especially since it is helped by EU subsidies.

There is anyway no doubt that the problem exists. To solve it or to reduce the risk of pollution, the agricultural engineers have a good deal of responsibility. The CEN is studying the problem and a number of standards is in preparation on:

- Controlling fertiliser distribution;
- Controlling pesticide distribution, both in the fields and in the orchards;
- Managing slurry and manure.

Finally it is not possible to ignore the directives 89/391/EEC, 89/654&655& 656/EEC, 90/269&270/EEC, 90/394/EEC and 90/679/EEC on the improvement of the safety and health of the workers on the worker place. These directives apply to all machines, but specifically to the machines manufactured before the Machine directive was recognised. This old machinery could beforehand follow the requirements of maybe obsolete national safety laws and standards. When a country adopts the above-mentioned directives, automatically the level of safety and ergonomics of all the installed machinery has to be equal and top level.

DISCUSSION

In spite of the above-mentioned activity carried out, the problems of safety and ergonomics in agricultural machinery are not easy to face and to solve. Each committee or ad-hoc group consists of different people with a different experience (manufacturers, standard experts, civil servants from the ministries of agriculture/labour/health/industry, executives of manufacturer associations, test engineers from testing stations, etc.). The result is the issue of standards contrasting in form and content in the different organisations.

The overlapping of competencies at national and international levels is not only for standard writing, but also for the control and judgement of execution and the acceptance of the standards themselves. The confusion may become higher in the relation between different countries, each time an import/export operation is necessary. In fact ergonomics and safety were often used in the past – and they are still exploited - as protective measures against import. As well as a product becomes dangerous for a national industry, it is sufficient to severe standards and/or administrative practices.

Finally it must not be forgotten that ergonomics and safety have a high cost, depending on:

- The necessity to carry out research and tests;
- The standard writing;
- The machine design, prototype manufacturing, testing, etc.;
- The writing and print of decals, instruction books, etc.;
- The manpower training.

As a consequence agricultural machinery increases its manufacturing cost and – last but not least – farmers must pay for everything. On the other hand, if the social cost of accidents is taken into account, the final balance is positive for the national and European economies.

One last point: ergonomics and safety standards must be congruous with the country social and economical development. Otherwise:

- If too permissive, their application is too easy for the manufacturer. These standards are probably useless, from the point of view of increasing safety and ergonomics;
- If too strict, standards cannot be applied and all the work carried out is useless. An example is the EU directive on tractor noise at the driver's ear. Written more than 20 years ago, its application has been postponed different times. The problem was not the noise of the big and costly tractors, all with an excellent cab, but the small tractors with a two-post protective structure. The development of indirect injection diesel engines with different cylinders has finally permitted to reduce the noise level.

CONCLUSIONS

At the end of the second world war Europe was tired of hundreds – or may be thousands – years fighting. A few wise politicians decided to stop this trend and to begin a new era, through:

- The unique market of all EU;
- The abolishment of the borders between countries, permitted by common standards on safety and ergonomics;
- A common currency, the Euro.

EU has now 15 members, soon supposed to increase to 27 in two laps. The figure of future members is anyway open; for example our hosting country is certainly a possible candidate. A question is how to behave to lessen the long transitory period. From this point of view a must is surely to quickly apply the European safety and ergonomics standards in all the fields, and of course for agricultural machinery.

The task is not easy and full of obstacles. The agricultural engineers shall intervene through applied research to design/adapt/modify the machines and to render them safe and competitive.

REFERENCES

1. EC, 1974-2001, Directives, Brussels
2. EN, 1991-2001, Standards, Brussels
3. GASPARETTO E., (1989), Ergonomics standards in agricultural machinery and rural buildings; development and application, Proceedings, 11th International Congress on Agricultural Engineering, Dublin, 2799-2810
4. ISO, 1947-2001, Standards, Paris
5. OECD, 1959-2001, Standard codes for the official testing of agricultural and forestry tractors, Paris
6. Unacoma (Italian Farm Machinery and Earthmoving Machinery Manufacturers Association), (2001), Attività dell'Associazione (Assemblea Generale 19 giugno 2001), Rome



AGRICULTURAL ENGINEERING EDUCATION AND RESEARCH IN KNOWLEDGE-BASED ECONOMY

LINUS U. OPARA

Institute of Technology and Engineering
College of Sciences
Massey University
Wellington, New Zealand

SUMMARY

Engineering and technological innovations such as electromechanical equipment and process engineering have played significant roles in transforming agriculture and other land-based activities into modern industries that produce diverse range of top quality products and services. This success has been characterized by extensive mechanization of agricultural operations to increase cultivated areas and land-use intensity through the application of improved mechanical systems such as the tractor and protected structures for animal housing and crop cultivation. Progress in this era was driven principally by the availability of more efficient engine power and engine-powered mechanical devices for tillage, material handling and agro-processing.

Agricultural industries and agricultural engineering education and research face new challenges in a modern global economy that is increasingly knowledge-intensive and information-driven. Under the new dispensation, information becomes the 'engine' that powers future technological innovations in agriculture. In this article, we discuss a triad of emerging technological innovations (information and communication, biotechnology, and nanotechnology) that are underpinning the advancement of knowledge economies. A framework is outlined for greater attention to this techno-triad in agricultural and biosystems engineering education and research. Future graduates and professional agricultural and biosystems engineers must be prepared to undertake leadership roles in the fusion of this techno-triad in sustainable agriculture to develop and apply cost-effective supply chain technologies to manage variability (product and environmental), reduce production and transaction costs and maintain traceability in smart agriculture.

Key words Agricultural Engineering, Biosystems Engineering, knowledge economy, technological innovation triad, Agrinfortronics, supply chain technology, smart agriculture

INTRODUCTION

Rapid changes are occurring in the world and the agriculture that supplies our basic food needs. World population is increasing rapidly and is expected to nearly double from its present 6 billion people by the year 2035, with most of the growth occurring in the developing countries. In these regions also life expectancies are on the rise and as their economies emerge, consumers are having additional disposable income, which is expected to increase the demand for food. Concurrently, as population continues to rise, land available for agriculture is decreasing, and consequently, there is a need for increased agricultural productivity so as to meet the food (nutritional and dietary) needs of the rapidly expanding population.

On the other hand, in developed countries, significant changes are occurring in public attitudes towards agriculture vis-à-vis its impact on the environment and the quality and safety of food. Consumers are increasingly eating to reflect their lifestyle, convenience and personal habits. Consumption habits are shifting from high-energy, high-fat, high-cholesterol foods towards functional, healthier, and more nutritious fresh foods. With increasing awareness of the negative impacts of mechanized agriculture in reducing ecological diversity and contributing to soil degradation and environmental pollution, an influential group of consumers, scientists and lobbyists have emerged who question the sustainability of current agricultural practices. These consumers also demand for information on the life history (production and handling practices) of food products and are willing to pay a premium for these expectations as reflected in higher prices of organic products and quality and safety assured products (Opara, 2000b; Latouche, 1998).

As consumer food preferences continue to change, the introduction of genetically modified organisms and plants into the human food chain has increased the need for better knowledge of the interactions between agriculture, the environment and humans. It is therefore evident that not only is agriculture and the market changing - our responsibilities as agricultural and biosystems engineers, researchers, and educators are changing with it.

Technological innovations (new commercial products, processes and services) are leading weapons for economic progress and competitive advantage among companies and nations. The industrial revolution enabled the mass production of goods in large-scale factories. Agriculture benefited from this development, including the large-scale of mechanization of production, postharvest handling and processing operations. The overall success of any nation/region depended heavily on its natural resource endowment (land, water, minerals). Recent technological innovations that underpin successful modern day economies are however dependent on the generation, dissemination and intensive application of knowledge generated by investments in education and research. Successful businesses must therefore remain at the cutting edge of new frontiers of knowledge and information management.

With this background, the question that often comes up in one's mind is: what is future of agricultural engineering in the new knowledge-based economy, given that the profession emerged and boomed in an era that can be described as machine-based economy where the mechanization of agriculture increased cultivated areas, factor productivity and profits. Just as the application of the 'mechanical engine' provided the power to drive mechanized agriculture and mechanization removed the drudgery of muscle-powered operations, 'information' powers the knowledge that drives modern, sustainable smart agriculture.

The objective of this article is to discuss the leading technological innovations that are currently driving the global knowledge economy and to highlight their implications on future education and research in agriculture. Based on this synthesis, a framework is proposed for agricultural and biosystems engineering education that is necessary to meet the engineering challenges in knowledge-intensive agriculture.

THE KNOWLEDGE- INNOVATION NEXUS

Far-reaching changes are occurring in the way technological innovations influence business and our lives. As businesses and nations seek new ways to maintain profitability and competitiveness, it is now widely known that the ability to develop and utilize new knowledge and technology has become a weapon for business advantage and competitiveness. Successful firms are increasingly knowledge-based, with extensive application of information technology (IT) in the generation, dissemination and application of knowledge. Relying on regular production and supply of existing products and services that meet market quality standards is no longer sufficient to remain competitive in the future market. Firms and organizations that continue to operate in this mode have suddenly found themselves trapped in market niches or even excluded from the dynamic market developments (Williamson, 1975).

As existing knowledge crossed boundaries with increasing rapidity and most firms view themselves as knowledge-intensive where intellectual capital is the most value resource, the ability to continuously create knowledge has become a major challenge facing firms and organizations seeking to introduce new technologies that add-value to existing products and services. The availability of knowledge determined future competitiveness, and each organizations requires diverse, specialized knowledge workers who develop unique knowledge, and who collaborate to create new knowledge that enhances the performance of the organization (Ritcher, 2001; Garvin, 1993). This development has led to a paradigm shift from conventional innovation management, which focused on the generation of definite product and process innovation to systemic technology management, which emphasizes knowledge generation as basis for innovation (Ritcher, 2001; Ritcher and Vettel, 1995).

The emergence of the new knowledge and technological innovation as key drivers of economic competitiveness for the future is highlighted by the current world economic competitiveness ranking of nations, which places the USA, Singapore and Finland as the top three (IIMD, 1999). The core of USA competitiveness was attributed to its unique ability to grow using innovations, where technological breakthroughs are converted into commercial ideas, and which are then driven to create new business opportunities (Smith, 2000).

An innovation can be defined as a new product, process or service that is successful in the marketplace, and it is innovation activity which turns technological opportunities created in research and development into commercial reality (Lievonon, 2000). Thus, innovation entails the creation of unique value, which can be a new method, device, or service. It lies at the heart of the new technologies, applications, and products that create wealth and enhance human well-being (SIAC, 2000). In this sense, innovation can be viewed as transforming an idea from mind to market, and from lab to factory (including the farm)!

Sustainable economic growth by successful organisations and more advanced economies are characterized, among other factors, by widespread innovation and technological change that is supported by an effective innovation system. Dynamic economies, firms and disciplines are therefore characterized by innovation, and increasingly innovation provides the key to the increased competitiveness of these institutions.

There are three key elements in the innovation process: (1) developing and retaining skills, (2) generating ideas and undertaking research, and (3) accelerating the commercialization of the ideas into products and services (Commonwealth Australia, 2001). Providing people with *education* that enables them to develop appropriate skills and conducting *research* to generate ideas and new knowledge are fundamental prerequisites to the realization of innovative products and services that possess commercial value and benefit to society. Indeed, research is considered the lifeblood of innovation as it sustains long-term generation of ideas.

A TECHNOLOGICAL INNOVATION TRIAD

Having established the pivotal role of knowledge and technological innovation in future competitiveness, let us discuss briefly three knowledge-based, information-driven technological innovations that have potentials to transform the nature engineering and technological inputs into agriculture in the third millennium. These leading innovations of modern times represent the most significant outcomes, to date, of the ongoing biological and information revolutions.

Information and communication technology (ICT)

Advances in ICT have revolutionized our daily lives and spearheaded a new wave of industries. ICTs include user interfaces (such as hardware), application programmes (software) and databases. Computers and new information technologies such as the Internet, automatic teller machines and wireless communication have made it possible to rapidly collect, process and transmit information, and these developments are often considered to be the forerunner to the increasing globalisation of world economy. Development of the Internet (World-Wide-Web) and internet/web-based activities such as distance/online-learning and online-commerce and real-time exchange of data/information between researchers in different continents have accelerated the magnitude and frequency of collaborative activities, which creates a conducive environment for creative innovation.

This trend is set to increase as costs reduce amid rising computing capacity and availability of new types of software that improve existing business practices and human activities.

These developments represent technology-push factors that have applications in many areas of agriculture. For instance, the trend towards precision agriculture and supply chain management of farm products is only feasible with the availability of appropriate information about the inputs and on-farm and postharvest activities. The integration of computing techniques into livestock farming can realize automatic diagnosis, and such improvements may be strengthened by remote diagnoses and services based on wireless data telecommunication (Munack and Speckman, 2001). Geospatial technologies such as geographic information systems (GIS), global positioning systems (GPS) and remote sensing (RS) already have applications in on-line data exchange between stationary farm computers and mobile field machinery, thereby providing measured position data for agricultural machinery (Speckman, 2000). Monitoring and prediction of disease epidemiology, field mapping for yield and product quality variations, on-line quality and safety assessment of products and automatic measurement and control of the product environment are some of the beneficial impacts of ICT in agriculture. Having direct access to the Internet or other global networks and databases enable the farmer, consumers and other stakeholders in the agricultural supply chain to plan and make technical and economic decisions.

It has been suggested that agriculture is the growing giant consumer of ICT and electronic technologies (Sigrimis et al., 1999) in the quest to meet the multifaceted consumer demand for sustainable production of good quality, safe and traceable products using friendly environmental, ecological and animal welfare practices. The application of sensors and biosensors to the speaking plant approach during cultivation and speaking fruit approach for fruit during storage (De Baerdemaeker and Hashimoto, 1999), and the use of artificial neural networks, fuzzy knowledge-based systems and revolutionary algorithms represent new frontier for agricultural automation and intelligent control to meet the various needs of consumer of agricultural products and services in the 21st century.

Biotechnology

The conceptual basis of modern biotechnology is the DNA code maintained and interpreted in living cells. The ability to manipulate the genetic structure and composition of plants and animals has become one of the most ambitious and elaborate scientific projects of mankind as typified by the human genome project. Modern biotechnology has evolved as a merger of biochemistry, microbiology, medical sciences and industrial production technologies (Lievonon, 2000). Historically, the principles and procedures of biotechnology have been applied in agriculture such as in fermentation and other food processing and preservation techniques; however, success in genetic engineering of crops and livestock has opened up new opportunities and challenges at all steps in agriculture. Agricultural biotechnology is now a practical reality, resulting in animals and plants that have new genetic traits in productivity, disease and pest resistance, and which impart desirable attributes on the food product derived from genetically modified plants, animals and other organisms.

Let's examine some of the specific and potential consequences of biotechnology (particularly genetic engineering) on plants, animals and their environment which impact on the future role of agricultural engineers:

- alteration of the internal structure and constituents, phenology, physiology and overall architecture of plants and animals that represent the basic 'factories' of food and fibre creation. These effects could require changes in the design, operation and control of future mechanical devices and process conditions for field and postharvest operations;
- controlling the regulation and expressing of genes in plants has already resulted in commercial fruits such as the tomato which possess specific ripening and firmness characteristics. This may impact on the handling and storage requirements of products derived from these plants;
- introduction of new organisms for food processing and preservation will require the understanding of new process kinetics, optimal process conditions, and interactions between process conditions to produce desired food products;
- development of biosensors for processes characterization, and new tools for site-specific delivery of biocontrol agents will demand integrated understanding of the fusion between biology and the engineering phenomena governing these processes;
- new measurements and analytical tools to assess the ecological and environmental impacts of GM plants, animals and organisms;
- new knowledge in postharvest science and material handling technology will be required to maintain quality, safety, purity and traceability of GM-based products. Although companies can segregate GM- and non-GM product lines, contamination can still occur when the same handling and/or processing facilities are used. This creates a demand for innovations for rapid detection of products derived from GM materials.

Nanotechnology

Nanotechnology is a newly emerging field that combines fundamental science, materials science and engineering at nanometer scales (billionth of a meter) to the design and manufacture of structures and devices with dimensions about the size of a molecule. Developments in nanotechnology have resulted from the efforts of scientists and engineers working in separate fields such as chemistry, biotechnology, photonics and microelectronics. Although it is the least developed to date among the technological triads, the potentials of nanotechnology in diverse industries such as health, electronics and agriculture is considerable. The prospects for nanoprobe, living machinery, atom-moving devices, nanoresistors, nanowires, and nanorobots for industrial applications have been demonstrated by numerous researchers (Scientific America, 2001). Greater fusion between nanotechnology with other emerging high technologies offers greater potentials for realizing these potential technological and economic benefits (Lievonon, 2000).

Interest in nanotechnology emanates from the idea that the resulting structures may possess superior properties including chemical, electrical, mechanical and optical. Although biomedical research and defense for fighting cancer and building missiles have led investments in nanotechnology, the development of tools and techniques for characterizing

and building nanostructures has far-reaching applicability across many industries including agriculture.

Despite being in its early stages, what does nanotechnology hold for future agriculture and why should engineers in agriculture and other bio-industries be interested? Success in nanotechnology may result in the following:

- nanobots (miniature/micro robots the size of human blood cells or even smaller) which can be deployed by the billion, could explore every capillary and even be guided in for close-up inspections of neural details in animals during breeding and special on-farm diagnostics. Using high-speed wireless connections, the nanobots would communicate with one another and with other computers that are compiling the scan database (Beijing Review, 2000);
- nanostructures which can be implanted into plants and animals during growth and development to collect and transmit vital real-time data such as growth rates and physiological activities which provide clues on performance, productivity and exposure to environmental, chemical and physical hazards;
- increasing the carrying capacity of optical networks using nanowires and nanocircuits will make huge data mining and transmission more instantaneous. Agriculture and other bio-industries inherently generate large volume of data on the environment, crops, animals, inputs and processes (hence the emergence of bioinformatics as a subdiscipline in the mathematical and information sciences). Mining these data and integrating the results into an agricultural information system facilitates good enterprise management. As most farms and other agricultural enterprises are often located in rural areas distant from main communication centers, the development of high-capacity information networks will facilitate the collection, analysis and transmission of vital information which is the backbone of precision agriculture;
- the possibility of mechatronic nanostructures (such as smart nano-cards that collect and store data on product and process history) which can be implanted into plants, animals and transferred into batches of products derived from these sources offers a potential for integrated supply chain traceability.

ENGINEERING CHALLENGES IN KNOWLEDGE-BASED AGRICULTURE

The above discussion illustrates what the future might hold for engineering in knowledge-based agriculture in the third millennium. At the same time, the knowledge-innovation nexus impacting on business generally as discussed earlier also affects agribusiness. However, certain characteristics of agriculture (including changing consumer and public attitude towards agriculture, food and the environment) present additional challenges to the application of engineering and technological innovations in agriculture. The factors must be managed to ensure the competitiveness of agriculture and reverse its declining terms of trade and low factor productivity. So what are the practical engineering and technological challenges facing agriculture in an economy that is increasingly knowledge-based and information-driven; an era where increased knowledge of biology, information and computers and related technologies are set to dominate global business activities?

In order to successfully transform agriculture beyond the current elements of the industrial revolution era (typified by intensive application of mechanical power and chemicals per unit of land), many technological challenges and opportunities exist. Some of these are discussed below:

a) Agrinfortronics for managing variability

Agricultural processes and the resulting products are highly variable in quality and yield. Accurate information on the environment, crops, animals, processes, and their interaction is therefore needed to manage this variability in order to produce goods and services that meet demanding expectations of consumers and the general public. In the future, the fusion of ICT, mechatronics and nanotechnology for agricultural applications represents an area that is set to take agriculture beyond the feats of mechanization and automation. Successful fusion of the emerging technological innovation in agriculture requires the education of individuals with good knowledge of the data needs of agriculture and who can integrate these needs into the design of innovative devices and processes. Deciding what data to capture, the most cost-effective way to collect the data, analyzing and presenting the data and integrating the information into the overall agricultural supply chain management system requires increased attention.

b) Profitable small-scale farm mechanization

The majority of the human population still relies on small-scale subsistence agriculture for supply of their food, feed and fibre. Despite the resounding success achieved in medium- to large-scale agriculture, profitable mechanization of small-scale agriculture has eluded mankind. Agricultural biotechnologies such as genetic engineering have the potential to improve the situation through the availability of high-yielding materials that have resistance properties to pests and diseases. Agricultural engineering has the experience to continue to lead this charge armed with the emerging innovations such as ICT, biotechnology and nanotechnology.

c) Farming of marginal lands and fragile ecosystems

As world population, mainly in developing countries, continues to explode, and poverty limits their ability to access food and other resources, there is a need to increase the productivity of existing farms. Unfortunately, most of these farmlands have marginal fertility due to over-cropping and unfavorable agro-climatology. New scientific and technological inputs are needed to improve the productivity of these farms in order to step up food production in the affected areas.

d) Agricultural supply chain technology

The increasing globalisation of the world agricultural and food supply system demands greater vertical integration within and between firms in order to adequately managing variability and remain competitive. With ever-growing and changing consumer demand and consumption patterns, the assurance of consistent supply top quality, safe and traceable food products remain high on the trade agenda. Developing cost-effective supply chain technologies for precision agriculture, including site-specific farming, will provide farmers and postharvest operators the necessary tools to exercise better control over yields, product quality and safety. Recent food scares and public concern

over GM foods and the effects of these concerns in reducing public confidence in the safety of the human food chain have made traceability an important index of trade in agribusiness. Traceability chains are more advanced in the livestock industry, particularly in Western Europe; greater attention is required for bulk foods such as grains and processed foods as well as in the fresh produce sector.

e) Sustainable agriculture

Consumer demand for sustainable agricultural practices, animal welfare and waste minimisation has become imperative in modern agribusiness. This is reflected in rising global trade on eco-foods ('green labels') and demand for traceability from field to plate (Opara and Mazaud, 2001). However, in regions where poverty and food insecurity are major problems, there is concern that new innovations are needed to enhance yields and to control the incidence of pests and diseases under sustainable farming practices. Differentiation of foods in the market grown under different production systems is difficult based on sensory attributes, and consumers currently rely product labeling and certification of farms by relevant agencies. New measurement technologies are needed to detect product products from different production systems such as organic versus conventional agriculture. As new indices of sustainability emerge (including environmental, water resources, land resources, air, and biodiversity) and agriculture is increasing implicated as a major cause of extensive resource depletion, engineers and engineering profession will come under more public scrutiny to include sustainability issues in curriculum and adopt sustainability as a professional ethic.

f) Reforms in curriculum and research agenda

To realize the potential opportunities that the emerging knowledge-based technological innovations offer agriculture, there is a need to integrate these innovations into the curriculum and research agenda of agricultural engineering and related technical programmes servicing agriculture and other biosystems. The importance of the knowledge-innovation nexus and the role of education and research in generating innovative ideas have been highlighted earlier. We cannot ignore or pay lip-service to the technological drivers of competitive organizations and economies in the 21st century because the value of any profession is ultimately measured by its service to humanity and the ability of its graduates to gainful employment. Introducing curriculum reforms that equip future agricultural engineers with skills that broaden their employment prospects into other service industries and the knowledge industry would make the profession more attractive to young school leavers (Opara, 2001).

PROSPECTS FOR AGRICULTURAL ENGINEERING EDUCATION AND RESEARCH

In order to harness the opportunities of emerging technologies in agriculture, a broad-based approach is needed that includes educational curriculum reform and re-orientation of the research agenda from a historical emphasis on 'machines' to information, process engineering and system integration. We must make agricultural and biosystems engineering appealing to young school leavers, and one of the obvious ways of doing this is to ensure that our curriculum enables them to acquire skills that transcend the boundaries of

agriculture. Admittedly, curriculum and educational reforms are often slow in many countries and institutions to match the pace of general economic transformations (Cortez et al., 2001).

However, we must be cognizant of the fact that increasingly, only a small proportion of graduates in a discipline area find job in the conventional industries serviced by that discipline. For instance, in a study at the University of California, Berkeley, Prausnitz (2001) reported that only 20% of their recent chemical engineering graduates work in the conventional chemical and petroleum industries. Interestingly, most recent graduates found employment in industries that either did not exist 10 or 20 years ago, or did not, until recently, discover the usefulness and relevance of chemical engineers in their operations. Agricultural engineering educational programmes must expand the job prospects of graduates beyond agriculture, to include other biological industries and knowledge-based industries.

My concern about the future of the agricultural engineering profession in the knowledge-based economy is deep-rooted in the undeniable fact that agricultural engineering is part and parcel of the society it serves through the products and services that our profession provides. Therefore agricultural engineering must change because the world is changing, stimulated by emerging technological developments as well as wider developments in the economic and socio-political arena. Like other disciplines, the fundamental existence of agricultural engineering is its response to society's needs and expectations (Prausnitz, 2001).

Part of the professional evolution and change must be to embrace the technological innovations that are determining future competitiveness in industries and national economies. But this alone is not sufficient to succeed in the 3rd millennium. The profession needs to place more emphasis on sustainable and environmental agricultural practices. The failure of several farm mechanization programmes in developing countries particularly in the 1970-80s with the resultant grave-yards of heavy duty machinery and soil degradation is all too easily blamed on 'local conditions' but the consequences on public perceptions and attitude towards agricultural engineering are damaging. More attention is needed to reduce agricultural pollution and development of energy-saving devices. We must see beyond the technical feasibility of new products and processes and pay more attention to the socio-economic context in which these innovations will be used.

Consumer demand and expectations of agriculture has evolved in emphasis from quantity to quality and safety of products and processes. In recent times, consumers have also expressed interest in the type of production system, livestock welfare and the genetic constitution of food materials. Consequently, traceability of food products and processes in the supply chain has become paramount. In the increasingly competitive global food trade, it is therefore no longer sufficient to meet the quality specification of the products. More attention is needed to develop traceability technologies for rapid and cost-effective product (or batch) identification and process characterization as part of an integrated quality assurance system.

Over the past three decades, a lot of emphasis has been placed on educating agricultural engineering graduates that are eligible to register as professional engineers, with little or no attention paid to educate graduates with engineering technology skills (often referred to as

‘Gold Collar’ workers). This approach has resulted in very limited availability of engineering technologist who possess hands-on project management skills to occupy the important middle technical cadre between professional design engineers and technicians. Often, it is these group of graduates that are better equipped to work at the interface of new technological innovations and industry. In many economies such as New Zealand where there is limited economy of scale for full-fledged agricultural engineering programmes, a Bachelor of Engineering Technology (Agriculture/Biosystems) might be what is needed to ensure a steady supply of much needed technical skills into agriculture and other bio-industries.

I want to finish by commenting on the issue of communication. One of the most noticeable changes that occurred in the agricultural profession at the close of the 20th century has been the wide adoption of biology as the fundamental science underpinning agricultural engineering – hence the change of many journal names, academic departments and professional societies to emphasise words like ‘biosystems’ and ‘biological’. My observation is that while considerable debate has taken place within most of the various national and regional professional bodies about these changes, the wider public and future students are less aware of these developments.

There is a need for increased and concerted effort to communicate through the media what agricultural and biosystems engineers do, how we do it and why. We need the inputs of leaders of the much larger and powerful agribusiness chains and agro-machinery industry to tell the public about us. We also need the agricultural engineers-turned politicians and policy makers to assist in communicating our roles and activities to the general public. All too often these contributions are obvious to us, but overwhelmingly the majority of society, our clients, and even our students are scarcely aware of what we think they know about us, and our profession.

In a recent focused study with undergraduate final year agricultural engineering students at Massey University (Opara, 2001), most of the students commented that people often asked them what agricultural engineers do (and this included their mates in other engineering and agricultural science courses). One of the students wrote in a questionnaire that followed the discussion: “Could someone write down what agricultural engineering means and does and give it to us so that we can use to explain to others when they ask us”; and another wrote: “Is there some database or website that has a list of influential agricultural engineers anywhere?” These sentiments reflect some of the well-known difficulties and challenges facing the profession. It should be said that despite name changes and curriculum reform these sentiments will likely continue in the foreseeable future amongst our stakeholders until we effectively address the issues of visibility in the community and communication with the wider society.

REMARKS AND CONCLUSIONS

Increasing globalisation, multi-functionality of agriculture, changing consumer and public perceptions and expectations, recent food safety scares and demand for sustainable agricultural practices have brought considerable pressure on agriculture and other biological industries to address declining consumer confidence in agriculture and the food chain.

The transformation of agricultural engineering in the new century to address these challenges and external factors is imperative. These challenges require greater knowledge and information to develop innovative products and process technologies that have the ability perform site-specific and process-exact functions. Improvements in prediction and control of machine performance, process outcomes and impacts on products and the environment will become more closely interrelated in importance in agriculture.

Implementation of quality assurance systems that include traceability of measurements, products and processes are now standard requirements in commerce. Success in meeting these requirements depends largely in our ability to harness innovative technologies such as the techno-triad discussed in this article. These technological innovations are knowledge-intensive and dependent of well-educated engineers and researchers who are capable of knowing what data/information to capture, analyse, interpret and apply towards equipment and process design and control. The strength of Agricultural engineering, as distinct from the fundamental engineering disciplines is that it lies at the interface or boundary of engineering and biosystems (including agriculture). As technologies are often developed at the boundaries of knowledge and disciplines, agricultural/biosystem engineers must therefore be at the forefront in the further development and application of emerging technologies in agriculture and other bio-industries.

The start of the new century presents agricultural engineers with unprecedented challenges, opportunities and responsibilities in research and in the education of new generation of biosystem engineers to meet the considerable technical challenges faced by agriculture and other land-based industries. These future engineers will increasingly need extremely sophisticated skills that would enable them to find jobs in other knowledge-based and service industries outside of agriculture. As a multi-faceted discipline, agricultural engineering will always be confronted with the bipolar pull of depth and breadth of its graduates. Hiring new faculty with more in-depth qualifications in areas (such as biological and information sciences) outside of the agricultural engineering discipline and increasing collaboration in teaching and research with these areas may be necessary to avoid curriculum over-crowding and resource duplication within institutions. Developing strategic relationships with major industry players and maintaining an effective communication system with our stakeholders are paramount for the success of agricultural/biosystems engineering in this new information age.

REFERENCES

1. BEIJING REVIEW. (2000.) Will my PC be smarter than I am? January 25 (Bilingual Club), pp. 1-4.
2. BUZBY, J.C. AND D. ROBERTS. (1999.) Food safety and international trade. *Choices*, 14(4): 23-27.
3. Commonwealth of Australia. (2001.) Backing Australia's ability: an innovation action plan for the future. Commonwealth of Australia, Canberra, ISR 2000/223.
4. CORTEZ, L., I. NAAS AND O. BRAUNBECK. (2001.) Agricultural engineering education programs in Brazil. *Agricultural Engineering International: the CIGR Journal of Scientific Research and Development*, Vol. III, 13 pages.

5. DE BAERDEMAEKER, J. AND Y. HASHIMOTO. (1999) Speaking fruit approach to the intelligent control of the storage system. Proc. 12th CIGR World Congress, Milano, Vol. I: 190-197.
6. GARVIN, D. (1993.) Building a learning organization. Harvard Business Review, July-August: 78-91.
7. IIMD. (1999.) World Competitiveness Handbook. International Institute for Management Development, Switzerland.
8. LATOUCHE, K. (1998.) Food safety issues and the BSE scare: some lessons from the French case. Food Policy, 23(5): 347-356.
9. LIEVONEN, J.T. (2000.) Innovation opportunities from fusing high technologies. Tech Monitor (Sep-Oct), pp. 22-28.
10. MUNACK, A. AND H. SPECKMAN. (2001.) Communication technology is the backbone of precision agriculture. Agricultural Engineering International: the CIGR Journal of Scientific Research and Development, Vol.III, 12 pages.
11. OPARAR, L.U. (2001.) What do undergraduate agricultural engineering students think about their discipline? Unpublished Survey, Institute of Technology and Engineering, Massey University, New Zealand.
12. OPARA, L.U. AND F. MAZAUD. (2001.) Food traceability from field to plate. Outlook on Agriculture, 38(4): 239-247.
13. OPARA, L.U. (2000a.) Historical evolution and tasks for agricultural engineering in the new millenium. Proceedings of the International Symposium on “Actual Tasks for Agricultural Engineering”, Zagreb, Croatia, pp. 1-19.
14. OPARA, L.U. (2000b.) Market-pull factors influencing perceptions on product quality in agribusiness (or quality assurance for who?). In Highley et al. (eds), Proceedings of ASEAN/APEC Postharvest Seminar, September, Hanoi. ACIAR Publication No. 100.
15. PRAUSNITZ, J.M. (2001.) Chemical engineering and the postmodern world. Trans IchemE, 79(Part A): 777-788.
16. RITCHER, F.J. (2001.) Systemic technology management - an organizational learning view. Journal of Scientific & Industrial Research, 60 (March): 284-290.
17. RITCHER, F.J. AND K. VETTEL. (1995.) Successful joint ventures in Japan: knowledge transfer through organizational learning. Long Range Planning, 28(3): 37-45.
18. Scientific American. 2001. Nanotech: the science of small gets down to business, Vol. 285, Number 3.
19. SIAC. 2000. New Zealanders: innovators to the world, turning great ideas into great ventures. A proposed innovation framework for New Zealand. Science and Innovation Advisory Committee, Wellington.
20. SIGRIMIS, N., A. MUNACK, Y. HASHIMOTO AND J. DE BAERDEMAEKER. (1999.) Prospects in agricultural engineering in the information age – technological developments for the producer and the consumer. Agricultural Engineering International: the CIGR Journal of Scientific Research and Development, Vol. I, 20 pages.
21. SMITH, G. (1999.) Australia's innovative environment compared with USA experience. Industrial Innovation Working Group, Canberra, 9 pages.

22. SPECKMAN, H. (2000.) Providing measured position data for agricultural machinery. *Computers and Electronics in Agriculture*, 25: 87-106.
23. WILLIAMSON, O.E. (1975.) *Markets and hierarchies: analysis and antitrust implications*. The Free Press: New York.



DOBRA STRUČNA PRAKSA¹

M. ČULJAT

Vijenac Kraljeve Sutjeske 9, Osijek

SAŽETAK

Dobra stručna praksa temelji se na znanju, kulturi i poštenju. Okrenuta je suncu, tlu i vodi, kao glavnim poljoprivrednim resursima. Sedam ključnih riječi (pojmovi) je u prethodnim rečenicama. Prve tri riječi (znanje, kultura i poštenje) stavljaju na pravo mjesto (zamjenjuju) pojmove: čovjek, ljudi, vjera (religija), politika, stranke, mafija, struka, znanost (nauka), društvo, veselje, država, vlada, dadžbine, nameti, strahovi, represije, vojske, oružje, ratovi, siromaštvo, bijeda, poniženost, napuštenost, bolesti, socijalne i dobrotvorne organizacije ..., a druge tri - sunce, tlo i voda su dâna (za sada nezamjenjiva) počela i ne raspravljamo o tome tko ih je dao.

Na Zemlji ima svega dosta za sadašnja i buduća živa bića, ali je raspodjela trajno nepravedna i nepredvidiva. Pravedna raspodjela otupila bi razvoj, isključila borbu za opstanak i promjene učinila nepotrebnim. Priroda je stoga nepravedna radi sebe. Čovjeku je stoga dodijelila sposobnosti spoznavanja da bi mogao kulturno i pošteno korigirati prirodne nepravednosti radi sebe. Radi opstanka ljudske vrste.

Dobra poljoprivredna stručna praksa pretpostavlja vješto korištenje najviših znanja na način da se iz prirode uzima koliko treba, a da se pri tome biljno stanište popravlja. Da se uzima stalno sve više, a da stanište bude sve bolje.

Dio ljudi u najjačoj životnoj dobi zaboravi da su dugo bili mladi i ovisni, te da će, ako budu imali sreće, dugo biti stari i nemoćni, pa u tom periodu superiornosti i moći postupaju gramzljivo, egoistično i bezobzirno. Do određene životne dobi ljudi nisu skloni poklanjati; ne osjećaju potrebu za poklanjanjem.

Prelaskom u period treće dobi, u najljepše (sedmi do deseti) decenije života, nije moguće natjecati se s mladim vrhunskim svjetskim istraživačima u izdašno financiranim institutima. Ali moguće je (i to veseli) informiranje i točno razu-

¹ Pod ovim (pod)naslovom (*Gute Fachliche Praxis*) česti su tekstovi u časopisima KTBL-a (Kuratorium für Technik und Bauwesen in der Landwirtschaft = Skrbništvo za tehniku i graditeljstvo u poljoprivredi), gdje se navode konkretni podaci.

mjevanje znanstvenih dosega i prosudba mogućnosti njihove korisne primjene, opredmećenja; Uživanje u globalnom znanju i njegovim korisnim detaljima, što je smireno posredno istraživanje; Oslobođen mana najjače životne dobi čovjek podvrgava kritici praksu i razvojne programe u namjeri da se izbjegne ponavljanje pogrešaka; Ne nameće, već pripomaže da se preispitaju koraci prije izvedbe i ulaska u veliki trošak. Neke od spoznaja o mogućem razvoju iznosimo u ovom članku.

Ključne riječi: *znanje, kultura, poštenje, sunce, tlo, voda, dobra stručna praksa*

UVOD

Praktični poljoprivrednik ne može posjedovati sva znanja, ali mora razumjeti vrhove spoznaja u onome poslu kojim se bavi i imati pri ruci korisne podatke u vidu časopisa, priručnika ili, još bolje, u stroj ugrađenih programa s podacima, koji mu se na poziv ili, radi upozorenja, bez poziva pojavljuju na zaslonu (displeju, ekranu).

Naznačenu tehničku razinu nudi 21. stoljeće već i u samoposluzi; Razvijeni ubrzano rasprodaju tehniku iz prošlih stoljeća, prodajući ju zemljama u tranziciji i onima koje još nisu ni u toj razvojnoj etapi; Prodaju, a ne poklanjaju iako znaju da ih time unazađuju, ostavljaju iza sebe i u narednom periodu. Ne žele se ispričati za višestoljetno ropstvo, jer se boje da bi morali platiti odštetu, pa isprika nije upisana u Sporazumu o borbi protiv diskriminacije, potpisanom 2001-09-08. u Durban-u, gradu na obali Indijskog oceana u Južnoafričkoj Republici.

ZNANJE

Rezultati vrhunskih istraživanja već su ugrađeni u pasminu, sortu, sjeme, gnojivo, zaštitno sredstvo, ambalažu, strojni agregat, opremu ugrađenu u stajama i skladištima itd. O njima poljoprivrednik mora biti precizno informiran prije investiranja i prije početka korištenja. Izborom krive sorte promašili ste jednu sezonu; Izborom krivoga stroja imate teškoća desetak godina, a izgradnjom krivoga objekta negativne posljedice se očituju dvadeset do stotinu godina.

Opasnost i strah od pogreške u investiranju, a još više od ulaska u nove proizvodnje rađa oprez i otpor promjenama. A bez promjena nema razvoja. Primjeri otpora slavonskih ratara uvođenju stočarstva:

- *obrađujem 80 ha i ne mogu živjeti! Ali ja neću u stočarstvo ...* (Poljoprivrednik iz Đakova na Okruglom stolu savjetovanja AZMP, Opatija 2001.),
- *moramo li mi uvoditi stočarstvo?* (Direktor uspješne ratarske tvrtke, 2001),
- *mi moramo kupovati zemlje; Nama je zemlje malo; Ne treba nama stočarstvo! ...* (Upravitelj jedne uspješne i velike poljoprivredne zadruge 2001.)

Najvažnije promjene moraju se odvijati u **znanjima** i aktivnosti vodećih ljudi.

Oni donose najvažnije odluke pa su i eventualne pogreške najveće. Znanje se stječe učenjem i u tome je razlog zašto poslove moraju voditi ljudi koji su u godinama kada mogu brzo i kvalitetno učiti, usvajati nova znanja i imati hrabrosti za preuzimanje odgovornosti.

INFORMACIJE

Radnik koji upravlja strojem treba, primjerice:

- uputu o optimalnom i informaciju o trenutnom tlaku zraka u gumama,
- informaciju o vlažnosti tla i uputu o potrebi navodnjavanja u tim uvjetima,
- informaciju o prinosu u momentu i na mjestu vršidbe,
- uputu koliko gnojiva treba raspodjeliti, uputu kako podesiti raspodjeljivač baš za to gnojivo i dozu, te informaciju postiže li taj efekat nakon podešavanja stroja,
- uputu o podešavanju sijačice za izdvajanje sjemenja, dubinu ulaganja sjemenja, način njegova priljublivanja uz tlo, eventualnu istovremenu startnu gnojidbu ispod razine polaganja sjemenja, te trajno informiranje tijekom sjetve odvijaju li se svi postupci kako treba,
- uputu o podešavanju prskalice ili orošivača u pogledu tlaka, doze, kontrole miješanja, brzine kretanja, te informacije o stanju vlažnosti zraka, brzini vjetra, a tijekom rada stalne informacije o održavanju podešenih vrijednosti,
- ... Rukovatelj ne mora znati napraviti instrumente koji to mjere i obrađuju, ali ih mora znati koristiti.

INFORMATIKA

Na hektaru treba uzgojiti, primjerice, oko 70.000 do 120.000 kukuruznih ili sunco-kretovih biljčica ili korjenova šećerne repe, 500.000 do milijun biljaka pšenice ili soje itd. Rasponi optimalnih vrijednosti su veliki, jer se razlikuju proizvodni uvjeti. Učeni poljoprivrednik teži svakoj biljci osigurati podjednake i najbolje uvjete nicanja, opskrbe vodom, svjetlom i hranjivima. Treba mu **karta plodnosti** tla da bi mogao obavljati korektivne zahvate u sjetvi, gnojidbi i zaštiti baš tih biljaka i baš na toj njivi - tabli; Njivu meliorativnim postupcima dovodi, a onda trajno održava u stanju da je **tabla ravna**, s ujednačenim biljci korisnim (obradivim) slojem sa što manje nepoželjnih biljaka (korova) i sa što više poželjne faune tla.

Karta plodnosti desetak godina uređivane i ujednačene njive u ravnici je dosadna; Male su razlike, pa nije isplativo diferencirano tretiranje.

POŠTENJE

Kulturnom, učenom i ekonomski neugroženom poljoprivredniku lakše je biti pošten. Stabilnost razvoja posla utemeljena je na njegovu znalačkom radu, urednom podmirenju

obveza prema društvu i osjećaju sigurnosti; Osjećanju da je to njegovo društvo, država, zajednica država i Svijet, što ga čini ponosnim, uspješnim i stalno pokretanim na usvajanje novih znanja i vještina, na proširenje kulturnih vidika i na potrebu za kulturnim zabavljanjem. Poljoprivrednik postaje gospodin. Gospodin poljoprivrednik s dobrom stručnom praksom uživa u svome razvoju.

DOBRA STRUČNA PRAKSA

Mi proizvodimo prosječno **7 t/ha**, Europa **18 t/ha**, a Nizozemska, istina u zaštićenim prostorima, **250 t/ha paprike**. Ne znamo koliko proizvodimo luka po hektaru, ali znamo ga uvesti 80 % od potreba! Prosječni prinos luka u Nizozemskoj je 55 t/ha, pa dio viškova prodaju i u Hrvatskoj!

Mađarska proizvodi dosta odlične paprike različitih ljutina. Trebamo li mi proizvoditi papriku kad nam je Mađarska blizu, paprika im je odlična, a i jeftinija je od naše. Isto tako je i sa sirom, kobasicama ..., pa se postavlja pitanje trebamo li uopće proizvoditi ili uvoziti ili se preseliti u te zemlje gdje je sve to jeftinije?

Možda bi mogli otići tamo, vidjeti kako oni rade pa probati nekako tako raditi i kod nas. Ni tlo ni klima nam nije nepovoljnija od pomenutih zemalja, pa ako bi se dobro organizirali i radili kao naši susjedi imali bi višu proizvodnju boljih proizvoda i po nižoj cijeni koštanja.

Dobra stručna praksa svake godine usavršava svoje proizvode, podiže prinose, podiže bonitet tla smanjenjem okretanja, a povećanjem ulaganja organskih tvari zelenom gnojivom, gnojovkom, stajnjakom i korekcijama sadržaja nedostajućih makro i mikroelemenata.

Kad govedarstvo glavnim proizvodima (mlijekom i mesom) pokriva troškove, a kao dobit gospodarstvu ostaje stajnjak držanje goveda je opravdano. Ako se osim *držanjem* bavimo i *uzgojem*, pa dosegnemo više od 8.000 kg mlijeka ekstra kvalitete po kravi godišnje (jer kod tako visoke proizvodnje sve je usklađeno, pa je i mlijeko ekstra kvalitete) tada ćemo i bez stajnjaka imati dobit od oko 3000 kg/kravi mlijeka godišnje, što po cijeni od 2,75 do 3,0 kn/kg mlijeka (= 0,37 do 0,41 € = 0,73 do 0,8 DM) donosi dobit od 8.250 do 9.000 kuna po kravi (= 1.110 do 1230 € = 2.190 do 2.400 DM). Dobit po kravi je veća od prihoda po hektaru. A jedan hektar može proizvesti hrane za najmanje tri krave!

ZAKLJUČAK

Dobra stručna praksa u 21. stoljeću je precizna poljoprivreda.

Dobra stručna praksa ovladala je tlom, vodom i biljem, a u zatvorenim prostorima gospodari svjetlom, toplinom i sastavom zraka.

Dobra stručna praksa uz biljnu proizvodnju ima i stočarsku, težeći njenom optimiziranju po količini, tehnologiji, prinosenosti i rentabilnosti.

U budućim sjedinjenim državama Europe opstati će poljoprivrednici koji provode dobru stručnu praksu. Bit će ih vrlo malo, ali će proizvoditi dovoljno.

POGOVOR(I)

U iskonskoj prirodnoj borbi za opstanak i životinjski car – lav uzima koliko mu treba za udoban opstanak, ali ne više, jer naredni put ne bi imao odakle uzeti.

U poodmaklom razvoju ljudske zajednice na čelo ne dolaze najjači (oni su u sportskim arenama) niti najpametniji (oni su u znanosti), već slabi, impotentni i/ili obilježeni, pa umjesto da se sa svojim hendikepom ponosno nose (najveću ljubav okoline pridobivaju oni koji to mogu) postaju vlastohlepni, gramzivi i nezajažljivi. Da bi izgledali veliki moraju puno trošiti, a da bi mogli trošiti otimaju i zadužuju se. Ne pristaje njihovoj (umišljenoj) veličini da to čine izravno, pa za te poslove angažiraju sebi slične, postavljajući ih u krugovima oko sebe, otpuštajući im najprije desetinu ... Kad *mali opernate* grabe sve više, slažu krugove oko sebe ... Tomu pogoduju manje zatvorene cjeline (npr. manje države u tranziciji), pa su u njima i izraženi otpori globalizaciji - putu da od svih ljudi nastane jedan narod!

...

I trči, trči gazela u Africi,

Trči brže od najbržeg lava,

Trči da bi živjela!

I trči, trči lav u Africi,

Trči brže od najsporije gazele,

Trči da bi živio!

(Uvod u prezentaciju noviteta tvrtke JD 1992. g.)

APPROPRIATE EXPERT PRACTICE

SUMMARY

Appropriate expert practice suppose skilful utilisation of high level knowledge in manner of taking from nature just as much as it is needed taking thus care to improve environment. It is known that Earth's natural resources are almost sufficient for nowadays and future generations, but their distribution were not and never will be fair or predictable. A fair distribution of natural resources would dull the edge of development and make everlasting changes unnecessary. So, the nature is cruel and unfair for themselves. The humankind has been given ability to realize the nature in order to live in harmony with her and not to abuse the given gifts. The paper presents review of past and recent agricultural practice in Croatia, criticism of failures and future vision for farming in harmony with nature.

Key words: *Knowledge, culture, honesty, The Sun, soil, water, appropriate expert practice*



PRECIZNOST RAZLIČITIH GPS SUSTAVA U SLOVENIJI

M. LAKOTA, D. STAJNKO, T. VAUKAN

Fakulteta za kmetijstvo
Maribor, Slovenija

SAŽETAK

U poljoprivredu se također uvode napredak i preciznost, pa smo na tom području danas svjedoci nove ere razvoja koju zovemo precizna poljoprivreda. Precizna poljoprivreda nisu samo aplikacije na malim površinama, nego je to ekološki i ekonomski optimalno gospodarenje tлом. Osnova za takav pristup poljoprivredi je upotreba geoinformacijskih sustava (GIS) i sustava satelitske navigacije (GPS), kojima prostorno i vremenski utvrđujemo položaj strojeva, te pohranjujemo radne parametre zajedno s prostornim podacima. Preciznost GPS sustava se kreće od nekoliko metara do nekoliko centimetara. Za potrebe geoinformacijskih sustava u poljoprivredi zadovoljava metarska preciznost, dok je za vođenje poljoprivrednih strojeva potrebna centimetarska. Željenu preciznost postizemo pravilnim izborom mjerne metode i GPS prijemnika.

U radu je prikazana preciznost različitih GPS sustava pri određivanju položaja u prostoru, što predstavlja osnovu za mjerenje površina, opsega i puta, te praćenje strojeva u radu.

Ključne riječi: precizna poljoprivreda, mjerenja u prostoru, GPS, GIS

UVOD

Sistem satelitske navigacije (GPS) v zadnjem času vzbujaju vse večje zanimanje tako med amaterskimi uporabniki kot tudi med ljudmi, ki omenjeni sistem uporabljajo pri profesionalnem delu. K temu sta največ pripomogla razširjenost majhnih prenosnih naprav za orientacijo in določanje položaja v prostoru, kakor tudi velika natančnost profesionalnih merilnih instrumentov.

Kmetijstvo je zaradi specifičnosti narave dela, ki je vezana na prostor in čas, ena izmed zelo zanimivih panog za praktično uporabo tega sistema. Možnosti uporabe geoinformacijskih sistemov v kmetijstvu prikazuje slika 1. Na trgu je možno dobiti zelo

širok spekter GPS sprejemnikov, ki se razlikujejo po svojih zmogljivostih oz. natančnosti, ki jo lahko z njimi dosegamo, metodah merjenja in seveda tudi v ceni. Za različna opravila v kmetijstvu potrebujemo različne natančnosti položaja, zato je zelo pomembno, da izberemo iz ponudbe na trgu ustrezen sprejemnik in metodo določevanja položaja, ki bo ustrezala našim zahtevam.

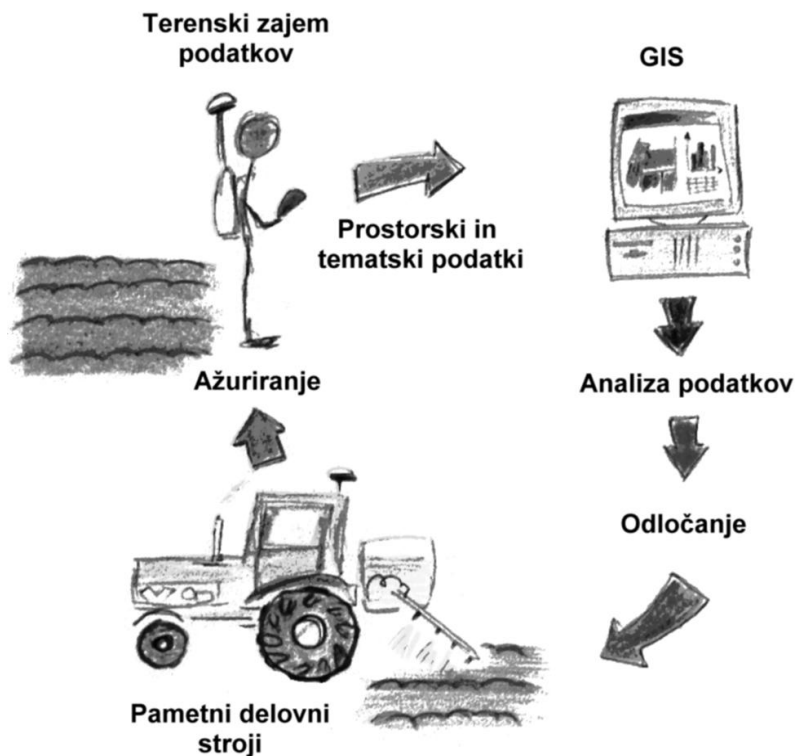

Slika 1: Prikaz delovanja geoinformacijskih sistemov v kmetijstvu

METODE ISTRAŽIVANJA

Meritve so bile izvedene 31. maja 2001 na Hmeljarskem posestvu v Radljah. Za ugotavljanje natančnosti določevanja položaja so bile uporabljene 4 različne metode:

- avtonomno določanje pozicije (GPS + antena),
- diferencialni GPS s kasnejšo obdelavo (PP-Post Processing) – DGPS-PP,
- diferencialni GPS oz. DGPS z ON-LINE korekturo in
- diferencialno merjenje faze – RTK.

Avtonomno določanje pozicije ali avtonomna navigacija je osnovni način meritve, ki jo v praksi imenujemo navigiran položaj. Za omenjeni način meritve potrebujemo samo GPS sprejemnik in signal najmanj štirih satelitov. GPS sprejemnikov za ta način meritve je danes v svetu največ in so najcenejši. Možnost merjenja navigiranega položaja so imeli vsi instrumenti, ki smo jih uporabljali pri meritvah. Za meritev statične točke je bil izbran GPS sprejemnik MLR SP 24.

Diferencialne meritve (DGPS) so podobne avtonomni meritvi le s to razliko, da v meritev vključimo popravke iz referenčne ali bazne postaje, kar lahko izvedemo kasneje (PP) ali takoj ob meritvah (ON LINE). Pri tej obliki meritve se v GPS sprejemnik poleg podatkov o položaju meritve zapisujejo tudi podatki o položaju satelitov. Ti podatki se nato primerjajo s podatki, ki jih je zapisovala referenčna postaja. Razlike, ki so nastale pri meritvah, se kasneje v računalniku popravijo (REINEX-irajo). Za ON-LINE meritve je bil uporabljen sprejemnik March II, ki smo ga preko mobilnega telefona povezali z referenčno postajo v Ljubljani. Vektor med referenčno postajo in krajem meritve je bil dolg 80,6km. Za DGPS-PP meritve je bil uporabljen sprejemnik Leica GS50.

Najzahtevnejši zlasti s stališča postopkov obdelave signala in vgrajenih matematično-statističnih metod v sprejemniku je način RTK. Gre za diferencialno merjenje s pomočjo faze nosilnega signala. Za ta način meritve potrebujemo sprejemnik in oddajnik, ki sta med seboj lahko oddaljena največ 30 km. Natančnost RTK načina meritve se ocenjuje na 2 cm in sodi v razred geodetske natančnosti.

Na geodetsko točko z znanimi koordinatami je bila postavljena lokalna referenčna postaja. Z mobilnim GPS sprejemnikom Leica SR530 so bile zajete koordinate še treh geodetskih točk za izvedbo lokalne transformacije iz koordinatnega sistema WGS84 v Gauss-Kruegerjev koordinatni sistem. V nadaljevanju meritev so bili na geodetsko točko nameščeni različni GPS sprejemniki, ki so v 30 sekundnih intervalih shranjevali podatke o položaju.

REZULTATI I DISKUSIJA

Slika 2 nam prikazuje položaj posameznega podatka točke glede na geodetsko točko, na kateri je bil nameščen sprejemnik pri avtonomnem načinu meritve.

Osnovna statistična analiza meritve je prikazana v naslednji tabeli:

	Y (m)	X (m)	Z (m)
SD	1,24	2,09	2,75
MIN Delta	2,58	2,59	5,56
MAX Delta	-1,68	-6,24	-6,01
interval:	30	sek	
največji radij:	6,44	m	

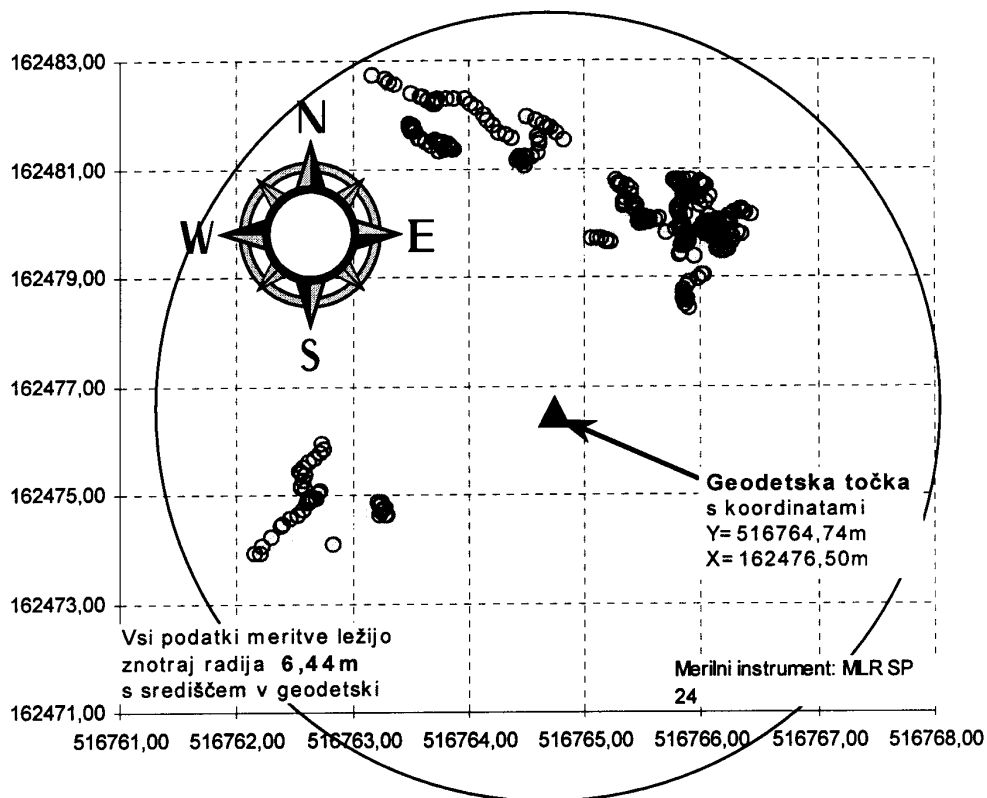

Slika 2: Položaji točk v avtonomnem načinu meritve

Slika 3 prikazuje položaje dobljene z metodo DGPS z ON-LINE časovnimi popravki.

Osnovna statistična analiza meritve je prikazana v naslednji tabeli:

	Y (m)	X (m)	Z (m)
SD	0,83	1,32	2,51
MIN Delta	2,81	3,24	10,92
MAX Delta	-2,87	-3,40	-10,98
Interval:	30	Sek	
Največji radij:	4,00	M	

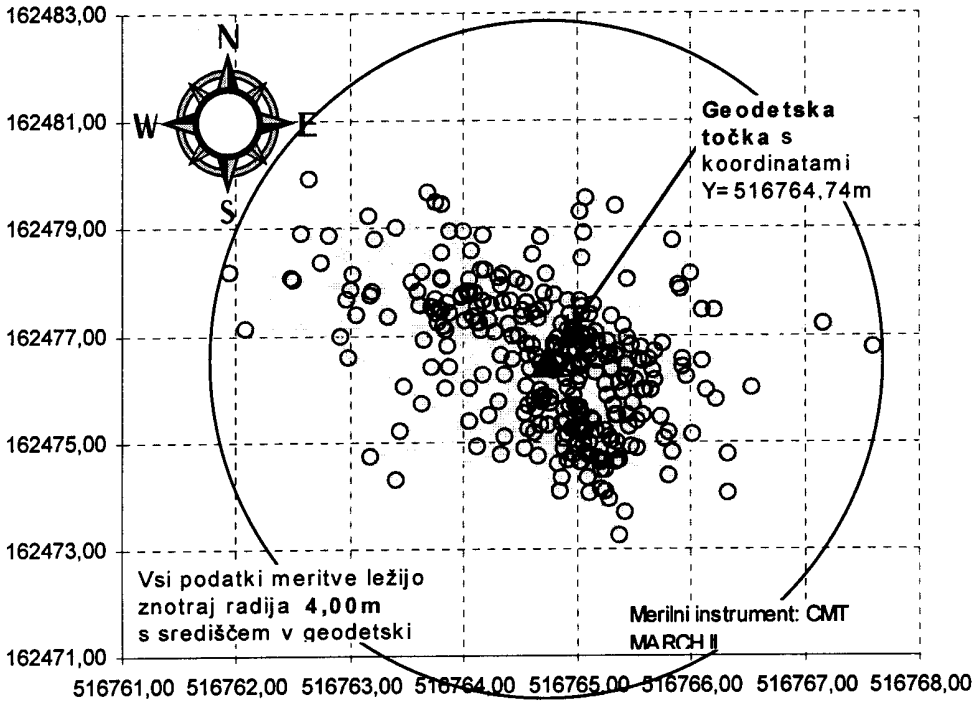

Slika 3: Položaji točk, izmerjeni z realno časovnimi popravki - DGPS

Slika 4 prikazuje rezultate dobljene z meritvijo s kasnejšo obdelavo podatkov - DGPS PP.

Osnovna statistična analiza meritve je prikazana v spodnji tabeli:

	Y (m)	X (m)	Z (m)
SD	0,14	0,32	
MIN Delta	0,22	0,46	
MAX Delta	-0,41	-0,48	
interval:	30	sek	
največji radij:	0,52	m	

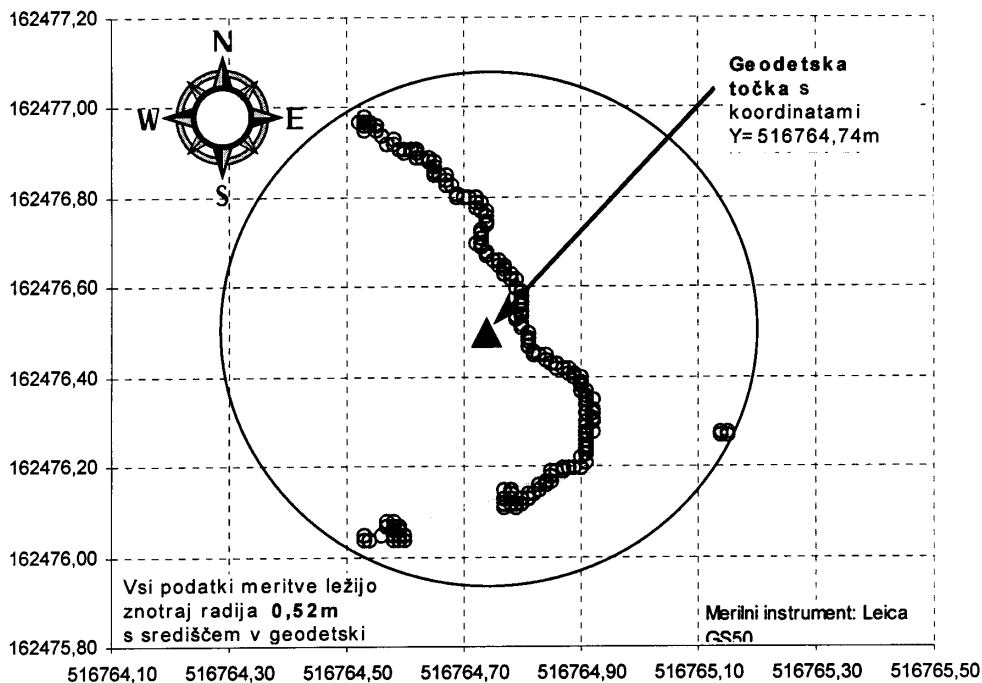

Slika 4: Položaji točk s kasnejšo obdelavo - PP

Slika 5 prikazuje rezultate meritev dobljene z metodo RTK.

Osnovna statistična analiza meritve je prikazana v spodnji tabeli

	Y (m)	X (m)	Z (m)
SD	0,02	0,00	0,01
MIN Delta	0,01	0,02	0,03
MAX Delta	-0,01	-0,01	-0,03
interval:	30	sek	
največji radij:	0,02	m	

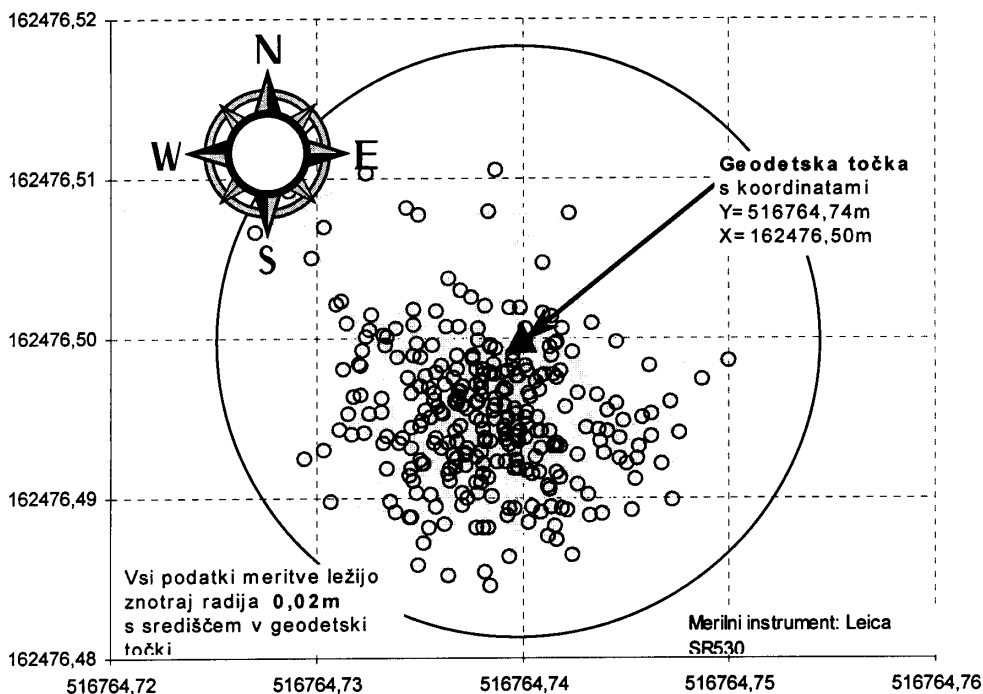

Slika 5: Položaji točk, izmerjeni z najnatančnejšo metodo GPS meritev - RTK

ZAKLJUČCI

Dobljeni rezultati prikazujejo da lahko z avtonomnim načinom določevanja položaja dosežemo natančnosti v mejah 10 m, kar je dovolj za pridobivanje osnovnih podatkov v geografskih informacijskih sistemih. Za natančnejšo pozicioniranje je potrebno uporabiti DGPS metodo s katero smo dosegali natančnosti v mejah 0,5 m, kar že predstavlja dobro osnovo za precizno kmetovanje. Najnatančnejša metoda RTK s katero smo dosegli natančnosti v mejah 2 cm je zaenkrat za uporabo v kmetijstvu še predraga, kar se v prihodnosti lahko hitro spremeni. V bodoče se vidi možnost uporabe GPS sistema tudi za vodenje, krmiljenje in regulacijo kmetijskih strojev in priključkov, kar pomeni, da bodo kmetijski stroji sami opravljali določene vrste dela glede na prostor in čas. To bo predstavljalo verjetno vrhunec v uporabi GPS tehnike.

LITERATURA

1. BILBAN G.; (2001) Terenski zajem podatkov z GPS, Geoservis d.o.o. interno gradivo, Ljubljana.
2. DANA H. P.; (1999) Global positioning sistem overview.

3. KILAR B. et al.; (1990) Referati s predstavitve GPS sistema ASHTECH Univerza v Ljubljani, FAGG OGG, Ljubljana.
4. KVAMME K.; (1997) Geografski informacijski sistemi, Znanstveno raziskovalni center Slovenske akademije znanosti in umetnosti, Ljubljana.
5. KVAS D.; (1995) Možnosti uporabe GPS tehnike v geodetski izmeri, Magistrska naloga, Univerza v Ljubljani, FAGG OGG, Ljubljana.
6. LEICK A.; (1995) GPS Satellite Surveying.
7. STOPAR B., PAVLOVČIČ P., KOZMUS K.; (1999) Uporaba GPS meritev v geodetski izmeri, FAGG OGG, Ljubljana.
8. VAUKAN T.; (2001) Satelitska navigacija kot osnova za geoinformacijske sisteme, Diplomsko delo, Univerza v Mariboru, Fakulteta za kmetijstvo Maribor.

PRECISION OF DIFFERENT GPS SYSTEMS IN SLOVENIA

SUMMARY

In agriculture also, progress and precision have set in. In this way we nowadays live in a new area of agricultural development called precise agriculture.. This term does not only refer to an application on small surfaces, but it means, above all, the best form of dealing with soil from an ecological and economical point of view. Precise-agricultural farming is based on using geoinformation systems (GIS) as well as global positioning system (GPS). The accuracy of the GPS – it includes determining time and position in space – varies between several meters and a few centimeters. Concerning the geoinformation system, the accuracy in metres is required in agricultural, whereas that one in centimeters is demanded in steering agricultural machines; both accuracy levels are easily achievable by choosing a proper measuring method.

In the paper, authors describe four different GPS systems and research their capabilities for determining the position in the space, which is the basis for measuring surfaces, circumferences, ways, and accompanying agricultural machines under working condition.

Key words: *precise agriculture, space measure, GPS, GIS*

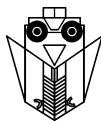

STROJNI PRSTENI U SLOVENIJI

MARJAN DOLENŠEK

Kmetijsko gozdarski zavod
Novo mesto, Slovenija

SAŽETAK

Praćen je razvoj strojnih prstena u Sloveniji od 1994. godine. U to vrijeme organizirano je 45 strojnih prstena, koji praktički pokrivaju čitav teritorij države i u 2001. udruživali su 5146 članova (poljoprivrednih imanja). U 2001. godini izvršili su oko 100 tisuća strojnih satova usluga. Strojni prsteni pokazali su se kao efikasan način smanjenja troškova mehanizacije i mogućnost praćenja najnovije tehnologije i na manjim imanjima. Članstvo i rad preko SP za poljoprivrednike koji dugoročno računaju ostati u tom poslu jedan je od fiksnih dijelova gospodarenja.

***Ključne riječi:** poljoprivredna mehanizacija, troškovi, strojni prsteni*

UVOD

Moderna poljoprivredna proizvodnja više nije moguća bez suvremene poljoprivredne mehanizacije. Istovremeno mehanizacija predstavlja najveći pojedinačni udio troškova proizvodnje. Naročito na manjim proizvodnim jedinicama (imanjima) ti troškovi zbog zakona punih brojeva kod strojeva i malog obima proizvodnje znatno smanjuju ostatak prihoda. Moderna mehanizacija sve je savršenija, veća i efikasnija na jednoj, a sve skupa na drugoj strani, pa ograničena investicijska mogućnost brojnih proizvođača onemogućava participiranje u novim tehnologijama i njihovo mjesto na tržištu sve je slabije.

Pokušaji smanjenja ovih negativnih strana ekonomike upotrebe mehanizacije prisutni su sve od uvođenja prvih strojeva u današnjem smislu u 19. stoljeću (npr. vršalice), a naročito su došli do izražaja u 70-tim godinama 20. stoljeća, sa masovnim uvođenjem mehanizacije. Povećanje obima rada strojeva jedino je moguće realno rješenje. A pošto su mogućnosti pojedinih korisnika ograničene (ograničen obim površina), moguće je povećati obim rada samo sa korištenjem strojeva na više imanja. Poznati su oblici međususjedske pomoći (susjedi mijenjaju usluge sa strojevima i ljudskim radom), strojnih zajednica (zajednička

kupovina i vlasništvo a pojedinačni rad članova sa strojevima), poljoprivrednih poduzetnika (poduzetnik kupi strojeve i radi sa njima usluge) i strojnih prstena.

Strojni prsteni u biti su samo organizirani oblik međususjedske suradnje, koja zauzima veći teritorij (općina, više općina) i ima jasne principe za obračun rada po unaprijed poznatim i dogovorenim cijenama. Strojni prsteni juristički organizirani su kao udruge, i brinu se o izmjeni informacija među potražnjom i ponudom usluga svojih članova. Svi strojevi su u vlasništvu pojedinih članova, koji nude usluge. Strojni prsteni počeli su se organizirati u Njemačkoj prije 40 godina, danas prošireni su u 12 zemalja zapadne, srednje i sjeverne Europe. U mnogim zemljama strojni prsteni već su nadgradili osnovnu ulogu i postali centralno mjesto povezivanja i organiziranja rada poljoprivrednih proizvođača u i izvan poljoprivrede (komunala itd.). Principijelno su prihodi iz rada u okviru strojnog prstena oslobođeni na porez na prihod i obično se organizacijski rad subvencionira iz javnih sredstava.

METODE

Od 1994. godine praćen je rad i razvoj strojnih prstena u Sloveniji. Praćeni su podaci o broju strojnih prstena, broju članova (= poljoprivrednih imanja) u pojedinim prstenima, površina poljoprivrednih zemljišta koju članovi obrađuju i obim rada u strojnim satima. Isto tako su bili praćeni drugi parametri radova strojnih prstena, kao što su subvencije iz državnog proračuna, snabdijevanje članova sa radnim odijelima i drugo. Na pojednostavljen način je bila izračunata ušteda u nabavci mehanizacije (na primjeru traktora) zbog korištenja usluga u strojnom prstenu.

REZULTATI I DISKUSIJA

Historijski pregled

Mala agrarna struktura slovenske poljoprivrede na jednoj i poljoprivredna mehanizacija praktički na srednjoeuropskoj razini (po instaliranim kW, manje po strukturi i kvalitetu strojeva) opterećuje proizvodnju sa 30-35% troškova. Zbog toga je već rano došlo do potreba za korištenje strojeva među imanjima. Pored tradicionalno prisutne međususjedske suradnje i pojedinih pokusa sa strojnim zadrugama u 60-tim godinama prošlog vijeka, poslije 1970. počela je era strojnih zajednica, paralelno sa «motorizacijom» poljoprivrede. U 15 godina osnovano ih je bilo oko 6 tisuća od toga cca 10% sa pisanim ugovorom. Poboljšale su situaciju kod korištenja strojeva, naročito olakšale kupovinu, ali su brzo došle do poznatih problema, proizlazećih iz zajedničkog vlasništva.

Strojni prsteni (nadalje SP) su bili u stručnim krugovima već dugo poznati, ali prva objava u stručnoj literaturi nalazi se u 1986. godini, a prva općenita informacija za poljoprivrednike 1992. godine. Pravo informiranje o strojnim krugovima počelo je 1993. godine i prvi su formirani godinu kasnije. Tehničku i organizacijsku podršku nudila je poljoprivredna savjetodavna služba. Došlo je i do intenzivne suradnje sa tradicionalnim SP zemljama (Austrija, Njemačka). Bitno je bilo, da su stručnjaci iz Slovenije sakupljali informacije u tim zemljama i prenosili ih kući. Prijašnji pokuši u 80-tim godinama prošlog vijeka, sa prijenosom ideja, predavanjima itd. stranih stručnjaka, nisu imali efekta.

Formiranje SP išlo je usporedno sa uvođenjem siliranja u valjkaste bale, što je tipični rad u SP, pa je to u nekim sredinama pomoglo prodoru ideje.

Danas postoje pored strojnih prstena i drugi oblici korištenja strojeva među imanjima: neorganizirana međusudjedska suradnja, preostale strojne zajednice (cca 300 – 400 sa ponekim još preostalim strojevima) i poljoprivredni poduzetnici. Najviše ih radi na rubnom području Panonske nizine; obrada tla, sjetva, žetva, berba šećerne repe.

Organizacija, management i opći uvjeti rada

Strojni prsteni organizirani su kao udruge fizičkih osoba po zakonu o udrugama. Taj zakon dosta je liberalan i omogućava i ograničenu profitabilnu djelatnost udruga (npr. izvođenje komunalnih usluga, ali ni jedan SP to još ne radi). Upravni odbor i predsjednik zvanično vode SP, ali sve organizacijske radove za izvođenje usluga sa strojevima izvodi plaćeni vođa (manager). Do sada ni jedan SP nema zaposlenog vođu za puno radno vrijeme, što je dugoročni cilj svakog SP. Ministarstvo poljoprivrede, šumarstva i prehrane subvencionira organizacijske troškove u iznosu 50%, ali max. 3.000 EUR/SP i ispunjavanje minimalnih uvjeta (100 članova, 2,5 usluga strojnih sati/ha polj. zemljišta članova). Na prihode iz usluga članovima u SP ne plaća se porez na prihod do visine 290 EUR/ha zemljišta u obradi, ali max. 20 ha. Na rad pravnim osobama plaća se porez na prihod u visini 10% (kao dopunska djelatnost po zakonu o poljoprivredi). Kod poreza na dodanu vrijednost (PDV) vrijede općeniti uvjeti za poljoprivredu. 1996. godine osnovan je Savez strojnih prstena, koji povezuje, zastupa i servisira SP sa različitim materijalima potrebnim za rad (biro materijali, promocijski materijali, radna odijela) i brine se o transferu informacija i obrazovanju.

Razvoj strojnih prstena

Do zaključno 2000. godine formirano je 45 SP, koji praktički pokrivaju cijeli teritorij države. Kod formiranja pokušalo se slijediti principu, da se SP organizira na teritoriju sa najmanje 2 tisuće imanja, tako da bi tokom godina rada mogli očekivati oko 400 članova i puno zaposlenih vođa. 2/3 osnovanih prstena ima takav potencijal. Ukupan broj članova, kao i broj članova po SP raste, ali je još daleko od idealnog. U prosjeku obrađuju članovi strojnih prstena dvaput više poljoprivrednog zemljišta od prosjeka u državi (10,1 ha naspram 4,8 ha). Dva SP prestala su sa radom. U 2001. godini subvenciju države koristilo je 32 SP, koje istovremeno možemo računati za aktivnije.

Tabela 1. Broj članova strojnih prstena 1994-2001.

Godina	1994.	1995.	1996.	1997.	1998.	1999.	2000; 2001.
Broj SP	21	34	39	40	42	44	45
Broj članova	944	2.116	2.884	3.496	4.033	4.713	5.146
Članova/SP	45	62	74	87	97	107	114

Svake godine veći je obim usluga koje su izvršili članovi SP. Ako izvršimo proračun strojnih satova na broj traktora (450 h/godinu), vidimo koliko manje je bilo potrebno investicija u strojeve, pošto su koristili usluge drugih. Naravno, to je samo paušalna ocjena radi primjera i ne izdrži znanstvene presude. U 2000. i 2001. godini izvršeno je oko 100.000 strojnih satova usluga. Nužno je naglasiti, da su ovo samo sati, za koje su izvođači radova naručiteljima napisali potvrdu, račun za zaračunani iznos. Stvarni obim usluga je po procjenama 3 do 4 puta veći, ali nije dokumentiran.

Tabela 2: Usluge u strojnim prstenima u godinama 1994-1999.

Godina	1994.	1995.	1996.	1997.	1998.	1999.
Podaci za ... SP	-	14	25	27	36	32
Ukupno ha	5.000	14.139	31.812	54.136	66.685	80.584
h/ha	-	1,4	1,4	2,0	1,8	1,7
h/SP	-	1.010	1.272	2.005	1.852	1.752
h/članu	-	12	14	15,5	16,5	17,1
traktora a' 450 sati	11	31	71	120	148	179

Po strukturi radova najveći obim imaju svi oblici žetve (žetva žitarica i kukuruza, berba šećerne repe, spremanje silaže u bale, siliranje kukuruza), slijede sjetva, transport, šumski radovi, obrada tla, zaštita bilja itd. Po procjenama kao usluge izvrši se preko 90% siliranja u bale i žetve pšenice i kukuruza za zrno i preko 95% berbe šećerne repe.

Najveći deficit trenutno je kod zaštite bilja zbog problematičnog rada. Očekuje se porast potražnje kod siliranja kukuruza (samohodni kombajni), obrade tla i sjetve (kombinacija), te kod uređenja okoline i komunalnih radova.

Praktično nerazvijeni oblik je korištenje usluga radne snage, kako u socijalnim slučajevima (bolest, udes itd.) tako u slučajevima gospodarske potrebe (manjak radne snage, korištenje odmora).

ZAKLJUČAK

Po početnom elanu nakon formiranja u brojnim SP može se osjetiti neki «prazan» hod i postavlja se pitanje kako dalje. Poneki SP ne uspijevaju uključiti očekivani broj poljoprivrednika i postići planirani obim rada. Često se postavlja pitanje kako rad u SP učiniti još interesantnijim. Savjest o smanjenju troškova obično nije dosta, pošto donosi efekte tek na dugi rok i ponekad uopće nije tako uočljiv kao kupovina jednog novog stroja. U brojnim SP nisu (još) odgovarajuće riješili pitanje vođenja (managementa). Često postoji problem kako naći i platiti vođu. Ima dosta mladih ljudi sa poljoprivrednim obrazovanjem, a samo rijetko tko vidi u SP pravo radno mjesto. Činjenica je, da je često to radno mjesto potrebno tek izgraditi i da je potrebno vlastitom inicijativom osigurati dio prihoda za plaću. Ali dobro riješeni primjeri pokazuju, da takva situacija nudi i puno slobode kod rada.

Za puno poljoprivrednih imanja uopće nije više moguće zamisliti rad bez korištenja i/ili izvođenja usluga u SP. Strojni prsten kao jedan neophodan dio gospodarenja dolazi polako ali sigurno.

LITERATURA

1. CIZEJ, D.: (1988) Kmetijska pospeševalna služba.- ČZP Kmečki glas, s. 171 - 186
2. DOLENŠEK, M, JERIČ, D. (1997) Združenja za medsosedsko pomoč - strojni krožki. Ljubljana: Zveza združenj za medsosedsko pomoč - strojnih krožkov Slovenije. 43 str., ilustr
3. DOLENŠEK, M. (1996) Strojni krožki. Zakaj, od kje in kam ?. Orač, glasilo SK Savinjska dolina, , št. 1, str. 4-6.
4. DOLENŠEK, M. (1998) Socialna in delovna pomoč v strojnih krožkih. Glasilo SK Litija, št. 2, str. 10-11.
5. DOLENŠEK, M. (1997) Izkustvo susjeda - strojni prstenovi. Jutro, Zagreb, let. 1, št 1 str. 32-33.
6. DOLENŠEK, M. (1998) Strojni krožki v letu 1997. Kmetovalec, let.65, št.3, str.29.
7. DOLENŠEK, M. (2000, 2001) Vloga strojnih krožkov pri pripravi lesne biomase in širjenju sodobnih tehnologij ogrevanja. Posvet: Biomasa – vir energije, Zveza društev za biomaso, Maribor, Novo mesto, Ribnica, Ilirska Bistrica, (4 krat), 15 str.
8. DOLENŠEK, M. (1999) Angepasste Maschinenringentwicklung in den Ländern Osteuropas und Schritte zur Maschinenringgründung – Fallbeispiel Slowenien. 12. mednarodni kongres strojnih krožkov, INTER MR, Keszteley. 7. str.
9. ERJAVEC E., DOLENŠEK, M. (1994) Strojni krožki. Kmetovalec, let.62, št.4, str.40-42.
10. GINDELE, E. H.: (1972) Die Bedeutung agrarstruktureller Elemente für eine rationelle Arbeitserledigung in der Feldwirtschaft, KTBL Schrift 156.- Landwirtschaftsverlag, Hiltrup, s.13-16, 119 – 196

MACHINERY RINGS IN SLOVENIA

SUMMARY

The paper presents results of monitoring machinery rings function in Slovenia since 1994. At the beginning there were 21 machinery rings with 944 farmers, while in 2001 there were 45 machinery rings with 5146 farmers who has completed 100 thousand machine working hours. Machinery rings have been showed as efficient way of reducing machinery costs and also means that enable small farmers to use up to date technology on their farms. This kind of cooperation will be efficient way to survive for farmers who decides to keep up with farming.

Key words: *Machinery rings, farmers, slovenian agriculture*

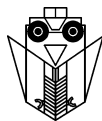

OPTIMISATION OF A CEREAL GROWING FARM'S MACHINERY OPERATING TIME

KALVI TAMM

Institute of Agricultural Machinery
Estonian Agricultural University
Tartu, Estonia

SUMMARY

In the previous articles the author has treated methods and formulas to prognosticate farm machinery optimum yearly average operation time i.e. also farm's cereal-growing, concerning biological, technical and economical factors and relations, affecting cereal production. Farm profit and profitability were used as optimisation criteria. To constrain the problem were used the limit – the farm is mainly based on the work of a single person (boss) and a single tractor. In this paper it is studied, how it is possible to prognosticate farm machinery optimum yearly average operation time, if there is more than one tractor in the farm and more than one person is working.

Key words: cereals, crop production, farm planning, optimisation methods, work organisation, farm machinery, job performance, sowing date, profitability, combine harvesters.

INTRODUCTION

Production of cereals is mostly processed by operating the machinery. Operation of machinery has influence the yield, i.e. also the income on one side, but it is also one of the biggest sources of expense on the other side. Increasing the yearly operation time and amount of work of the machinery leads to decreasing costs per unit. Increasing the yearly amount of work is limited by agrotechnical terms. The crops yield depends on field works time and duration, and affects the farm income. From the point of view of the development of the farm it is essential whether the capacity of farm's machinery and capabilities, needed to get production, are in balance from the point of view of profitability and if there is a misbalance, then how big the area of arable land must be to get maximum profitability with the current machinery. To get answers to these questions the researchers have tried to create

effective methods. One of them is the method, developed by the author and others [1, 2, 3], which helps to prognosticate farm machinery optimum yearly average operation time by farm's profit and profitability. Whereas, if earlier we used the limit, that the farm is mainly based on the work of a single person (boss) and a single tractor, then now it is studied, how it is possible to use this optimisation method, if there is more than one tractor in the farm and more than one person is working.

METHODS

The presumption, that there is more than one tractor in the machinery, turns the prognostication of complex performance of sowing works more complicated as in earlier manipulations. If there is only one tractor and one worker in the farm, it is impossible to do operations at the same time - it is possible to operate only serially and thus there is only one way to prognosticate complex performance of sowing works:

$$w_p = \frac{T_p}{\sum_{j=1}^u \frac{1}{w_{h,j}}} \quad (1)$$

where T_p - number of work hours per day, h;
 w_p - daily complex performance, ha/day;
 $w_{h,j}$ - hour-performance of one aggregate, ha/h;
 u - number of operations;
 j - order number of operation.

Whereas with one worker it is not possible to establish longer workdays than allowed for one person.

In comparison with the earlier situation, where there are several tractors and operators in the farm, we can get many more combinations of organising the sowing works and thus the prognostication of complex performance is also more complicated. In this case it is possible to perform operations serially, parallel as well as a combination of these two ways, like it is shown in the examples below. If there is more than one worker in the farm, it is possible to apply one set of machines in a number of operation periods (duration that is allowed for one person to work per one day, e.g. 10 hours) and thus it is possible to perform sowing works on the same area within a shorter period (in comparison with work day with one operation period) without significant investment in machinery.

By composing of activities schedule in a real farm we must consider the structure of the farm's machinery, work capacities as well as the number and qualification of workers. When organising the works we must take into consideration that

- aggregates should have maximum workload during the period, then operations are done on agrotechnically reasonable period, so that fixed costs would have possible

little part from work costs and at the same time all the needed works should done on right time, while the yield of crops is affected by the timing of works;

- in case of several aggregates previous operations should be performed before following operation, so that the aggregate performing previous operation does not obstruct the next aggregate from operating with maximum productivity;
- detectable optimum of work duration and thus the area of arable land would be in accordance with farm's harvesting resources, so that farm's harvesting machines would be loaded as much as possible and the yield would be harvested in time [4].

For these reasons it is possible to prognosticate the performance of sowing works in case of several tractors and workers only by iterative method, where playing through different scenarios, we are calculating complex performance for every distinct scenario and in costs we are considering presumable changes in the structure of the machinery and workers team. As best is chosen the scenario, which calculations result in the highest profitability for farm's cereal production. There is built an application for MS Excel that helps quickly to play through different scenarios.

In the examples we are using machinery, based on tractor MTZ-82 (Table1.). The prices used in calculations were in operation in the middle of year 2001. All prices are given without VAT (in Estonia 18%).

Table 1. Prices of machines on summer 2001 by data of sale firms.

Machine	Price, EUR	Count in farm	Sum, EUR
Tractor "MTZ-82"	9 476	2	18953
Drill	11 502	1	11502
Roller	2 708	1	2708
Carriage	4 874	1	4874
Harvester "DON 1500"	54 151	1	54151
Cultivator	769	1	769
Plough	5 686	2	11372
Sprayer	975	1	975
Harrows	918	1	918
Disc-harrow	2 708	1	2708
Fertiliser distributor	2 166	1	2166
		Total	111093

When determining the values of standards of seedbed preparation and sowing operations [5, 6] it is presumed, that 200 kg/ha of seed and 180 kg/ha of fertilisers are used on the average.

Table 2. Seedbed preparation and sowing operations and standards for them [5, 6]

Operation	Standard		Tractor, worker
	t/h	ha/h	
1. Cultivation with cultivator [5]	-	2,0	Tractor 1, worker 1
2. Transport of seed and fertilisers onto field, whereas loading is performed by hand with bags, distance 0,5 km [6]	3,0	7,9	Tractor 2, worker 2
3. Filling of drill with fertiliser from carriage [6]	3,5	19,4	Worker 2
4. Filling of drill with seed from carriage [6]	2,2	11	Worker 2
5. Sowing with drill (width 3,6 m) [5]	-	1,8	Tractor 2, worker 2
6. Rolling with rollers (width 5,2 m) [6]	-	3,0	Tractor 1, worker 1

RESULTS

The example plays through 3 samples, which are varying from the organisation of sowing works, the structure of machinery and workers team. As well, the variable costs used in the 3rd sample, differ from the variable costs used in the first 2 samples, while the costs on workers are higher. Variable costs are also depending on the yield. To get higher yield, we must do more treatments against pests, use more fertilisers and use seed with higher quality in comparison with low yields. Also for higher yields in comparison with low yields more time and energy is needed for harvesting. Variable costs, used in calculations are given in table 3. State's cereal support 25,6 EUR/ha is subtracted from variable costs.

Table 3. Variable costs, used in sample calculations, depending on the planned yield of cereals

Yield, kg/ha	Variable costs EUR/ha		
	Sample1	Sample 2	Sample 3
2500	138,1	138,1	146,7
3000	167,5	167,5	176
3500	198,3	198,3	206,9
4000	225,4	225,4	234,1
4500	253,2	253,2	261,9

Other variables, needed to calculate profitability [1, 2] of farm, are shown in table 4.

Table 4. Other variables, used in sample calculations, by different samples

Variable	Value		
	Sample 1	Sample 2	Sample 3
Complex performance, ha/h	8,4	18,8	25
Price of machinery, EUR	111093	167280	167280
Regression coefficient for spring cereals	0.001158	0.001158	0.001158
Regression coefficient for winter cereals	0.00192	0.00192	0.00192
Interest rate	0.1	0.1	0.1
Selling price of grain, EUR/kg	0,09	0,09	0,09
Spring crops share in sown acreage	0.75	0.75	0.75
National Insurance payment rate	0.33	0.33	0.33
Farm family maintenance costs, EUR/month	320	320	320

Sample 1

In the farm there are 2 tractors and 2 workers. We are using technological order, shown in table 2. Daily operation period is 10 h. The operations should be divided between workers so, that during the day they are loaded equally. Tractor 1 and worker 1 are performing operations 1 and 6; tractor 2 and worker 2 are performing operations 2, 3, 4 and 5. Accordingly we get for them complex performances (Formula 1):

$$w_{p,1} = \frac{10}{\frac{1}{2,0} + \frac{1}{3,0}} = 12 \text{ ha/day}; \quad w_{p,2} = \frac{10}{\frac{1}{7,9} + \frac{1}{19,4} + \frac{1}{11} + \frac{1}{1,8}} = 12,1 \text{ ha/day.}$$

For the general performance of sowing works, less complex performance should be used, i.e. in this sample 12 ha/day. If we are using coefficient $\tau = 0,7$, considering time loss due to weather conditions, then we get complex performance $0,7 \cdot 12 = 8,4 \text{ ha/day}$.

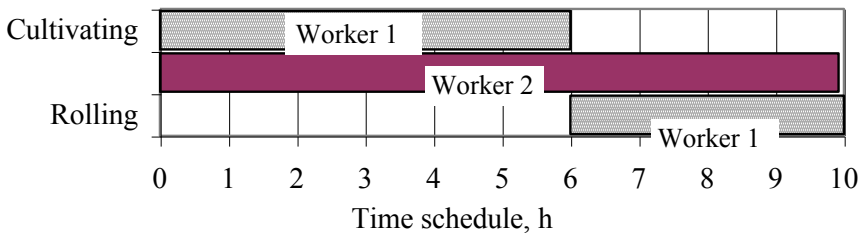

Figure 1. Distribution of cereals sowing works in one workday, ranged by order of performing

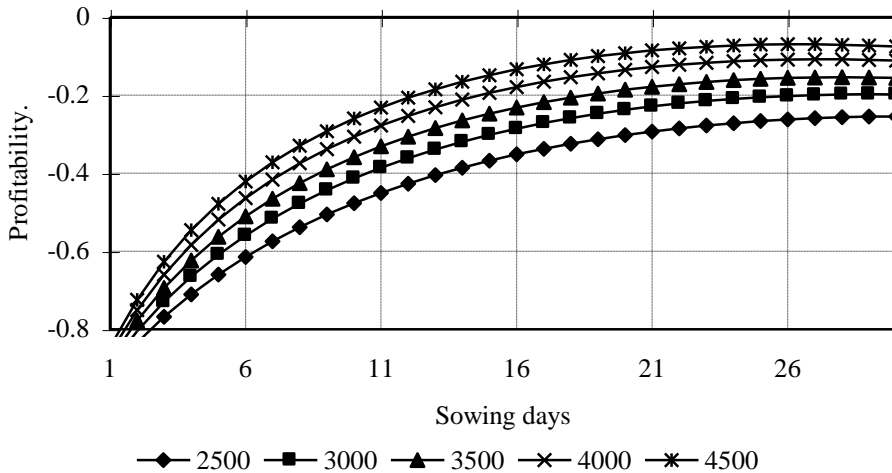

Figure 2. Farm's profitability as function of operation time (determined by sowing days of both spring and winter cereals by initial yields 2500...4500 kg/ha) by 1. sample

When planning work schedule for several aggregates, it is needed to notice, that previous operation should be performed before the next operation. In this case it is also ensured – Worker 1 cultivates 1,4 ha/h and Worker 2 performs operations connected with sowing with complex performance 0,85 ha/h. Worker 1 does cultivation with 6 h on 8,4 ha and the rest of the day (4 h) he is rolling already seeded field and ends this operation a little after drilling aggregate (Fig. 1).

Profitability of cereal production by sample 1 is shown on figure 2. In this case the profitability does not get positive value at all and thus, it is needed to find other possibilities to organise workflow.

Sample 2

Seedbed preparation, sowing and rolling after that are performed by seeding combination. The price of this machine is approximately the same as the price of a cultivator, a drill and rollers in total. The performance of seeding combination is 1,6 ha/h. There are two seeding combinations in the machinery. The daily operation time is 12 h. Seed combinations are operating parallel. There are 2 workers in the farm. Again operations should be divided between workers so that they are loaded equally. In this case both workers are performing the same operations during the workday.

So the complex performance (Table 2) for each aggregate and worker is

$$w_{p,1,2} = \frac{12}{\frac{1}{7,9} + \frac{1}{19,4} + \frac{1}{11} + \frac{1}{1,6}} = 13,4 \text{ ha/day.}$$

Complex performance in total for both aggregates is $13,4 \times 2 = 26,8$ ha/day. If we are using coefficient $\tau = 0,7$, then we get complex performance $0,7 \times 26,8 = 18,8$ ha/day.

The price of machinery, in this sample is 167 280 EUR, while there are 2 seeding combinations and we are using a western harvester (with work capacity 20 t/h and price 95 360 EUR) instead of DON 1500. Other initial data are the same. In this sample we can see (Fig.3), that cereal production is profitable by higher yields.

By the yield 4500 kg/ha we can get maximum profitability if the sowing duration is 23 days and thus the area used for cereal production, is 432 ha. The harvesting performance of the harvester at this yield is 4,44 ha/h. In Estonia we have suitable time for harvesting 170 h per season, so that theoretically it is possible to harvest 750 ha during the season. Considering with time usage coefficient 0,7, one harvester is able to harvest 525 ha of fields in reality and this is sufficient seasonal performance in this case.

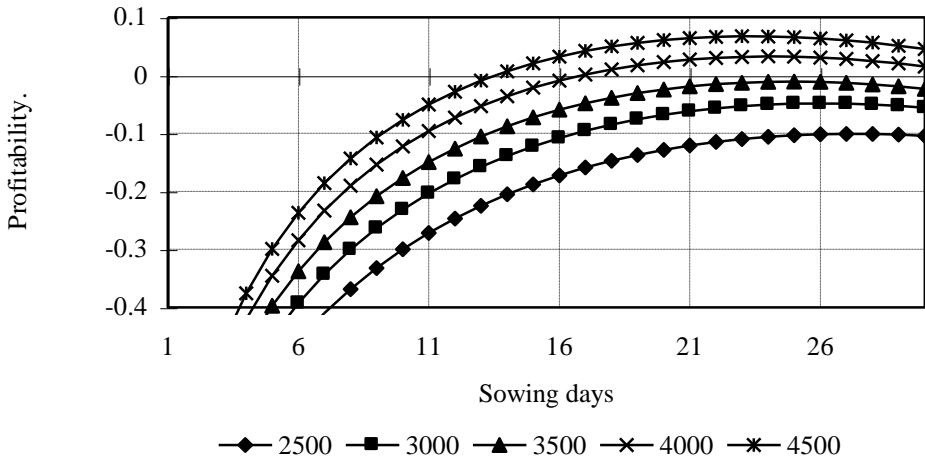

Figure 3. Farm's profitability as function of operation time (determined by sowing days of both spring and winter cereals by initial yields 2500...4500 kg/ha) by 2. sample

Sample 3

In the sowing season 2 more workers to 2 basic workers are added. Operations are performed during 2 operation periods per day - both 8 h long. All other organisation of

work is the same as in sample 2. So we have 2 parallel operating seeding combinations, each working 16 h per day.

Considering the time usage coefficient 0,7 the daily complex performance of aggregates is 25 ha in total. Because more workers are hired, the variable costs are bigger. Other initial data are the same as in sample 2. The results of calculations are illustrated in figure 4, where it is shown that, if sowing works are organised like in this sample, the production of cereals is profitable also by medium yields.

Optimal operation times of machinery, calculated in the 3rd sample, are shown in table 5. Criteria of optimality is profitability, whereas in the 1st variant production factors of both spring and winter cereals are used as input parameters and in the 2nd variant only production factors of spring cereals are used. As the profitability of production is negative by yield 2500 kg/ha, then there is no sense to expose values of optimal points for this initial yield.

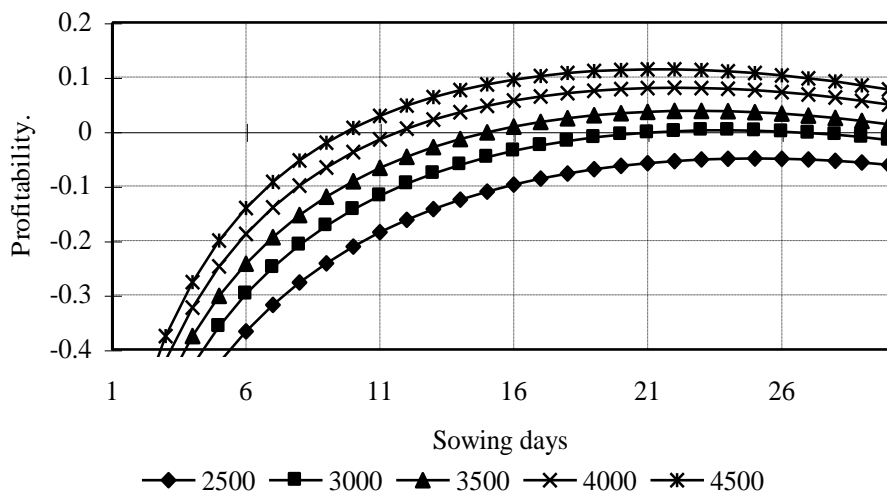

Figure 4. Farm's profitability as function of operation time (determined by sowing days of both spring and winter cereals by initial yields 2500...4500 kg/ha) by 3. sample

While the optimum area of cereals production is the biggest if the yield is 3000 kg/ha - 595 ha, then performance of the harvester is 6,67 ha/h by such yield. Considering the suitable time for harvesting to be 170 h per season, we see that theoretically it is possible to harvest 1134 ha during the season. Considering the time usage coefficient 0,7, one harvester is able to harvest 794 ha fields in reality and this is sufficient seasonal performance in this case.

Table.5. Optimal workload of farms machinery by 3. sample

Variance	Variables	Yield of cereals, kg/ha			
		3000	3500	4000	4500
1.	t , days	23.8	22.8	22	21
	F , ha	595	570	550	525
2.	t , days	21.7	20.8	20	19.5
	F , ha	543	520	500	487

Variables in table: t - duration of sowing period, days, F - area of arable land, what is possible to seed during the sowing period.

CONCLUSIONS

The method, used for prognostication of optimum workload of cereal-growing farm if in the farm there is only one tractor and one worker, is usable also in the case where there are several tractors and workers in the farm. We found out that in this case we can't prognosticate the optimum direct way like by a single tractor, but we must play through different scenarios of sowing works, to find optimum and profitability for every single scenario. By comparing profitability, found out by using different scenarios, the proper scenario will be chosen, the optimum of which shows, which should be the area of farm's arable land, to get the biggest profitability by currently used machinery. As we can see in the sample calculations, the sowing works scenario, ensuring the highest profitability in cereal production, were in sample No. 3. This is validated also by practice – in recent years seeding combinations and workdays with a number of operation periods, to get all the farm fields seeded within possibly short time during favourable sowing time, have been more and more used in Estonia.

The present research work was supported by ESF Grant No 2612.

REFERENCES

1. ASI, M., MÖLLER, H., SOONETS, K. TAMM, K., VETIK, R. (1999) Optimization of crop-growing farm and its machinery park parameters/ Actual tasks on agricultural engineering. Proceedings// 27. International Symposium on Agricultural Engineering// Opatija, Croatia, page 21..27.
2. MÖLLER, H., ASI, M., SOONETS, K., TAMM, K. (1998) Optimal use of machinery park in crop-growing farm/ Proceedings Informational Conference of Science: Machinery, soil, Harvest. -Kaunas -page 26...41.
3. TAMM, K., (1999) Optimierung der Grundparameter des Getreideanbaubetriebes nach der Belastung des Maschinenparks. Eine Dissertation zur Erlangung des Magistergrades im

Fachbereich der technischen Wissenschaften.; Estnische Landwirtschaftliche Universität. –Tartu, – s.80.

4. MÖLLER, H., ASI, M., SOONETS, K., TAMM, K., VETTIK, R. (2001) Machinery using in cereals farm. Transactions of the Estonian Agricultural Society. Nr 15. Tartu, page 49...50.
5. Põllumajandustööde normid. Mehhaniseeritud tööd. (1984) Eesti NSV Agrotööstuskoondise Info- ja Juurutusvalitsus. Tallinn. 383 lk.
6. Maatalouden työnormit. 1988/2. Työtehoseuran maatalous- ja rakennusosaston monisteita, 157 s.

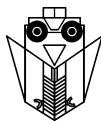

KVALITETA I UPOTREBA POLJOPRIVREDNO TEHNIČKOG ZAKONODAVSTVA U SLOVENIJI

RAJKO BERNIK

Sveučilište u Ljubljani
Biotehnički Fakultet, Odsjek za poljoprivredu
Ljubljana, Slovenija

SAŽETAK

Zakonodavstvo, standardizacija i različite strukture za ocjenjivanje sukladnosti proizvoda s propisima i standardima predstavljaju bistvene elemente u sistemu kvalitete. Svako blago, koje je u zakonskom prometu u jednoj od država članica Evropske zajednice, mora imati pravo do slobodnog prometa na svim prostorima zajedničkog tržišta. Proizvodnju i trgovanje s blagom na zajedničkom tržištu propisuju smjernice. Zakon o (fitofarmaceutskim) sredstvima za zaštitu bilja predstavlja jedan od važnijih zakona na području zaštite okoliša i zdravlja ljudi.

Ključne riječi: europsko tržište, tehničko zakonodavstvo, sigurnost, zdravlje.

UVOD

Strukture za usklađivanje, nadzor i ispitivanje moraju na svakom nacionalnom tržištu ispunjavati posebne zahtjeve, koji su izraženi u zakonodavstvu i u odnosu do korisnika i potrošača. Zbog toga moraju proizvođači svoje proizvode prilagoditi sistemu višestrukog provjeravanja u vezi sa zahtjevima tržišta, na kojima se proizvodi namjeravaju prodavati. Zakonodavstvo, standardizacija i različite strukture za ocjenjivanje usklađenosti proizvoda s propisima i standardima predstavljaju bistvene elemente u sistemu kakvoće. Sam sistem, koji je rezultat zakonodavstvenih akata ili propisa i suglasno prihvaćenih mjerila, snažno utječe na ponašanje pojedinca na određenom tržištu. Znači da mora svaki proizvođač, koji želi imati pristup do toga tržišta, obezbjediti da njegovi proizvodi odgovaraju nivou kakvoće koje zahtjeva taj sistem. Želimo li da tržište uspješno djeluje, cilj nam mora biti postepeno uspostavljanje zajedničkog tržišnog sistema s vlastitom razinom kakvoće, i to tako, da djeluje na sva tri područja: propisi, standardi i strukture za utvrđivanje sukladnosti, kao što su:

ZAKONODAVSTVO: država mora osigurati jasno razgraničenje nadležnosti uredovanja ministarstava za pripremu pravnih akata i pri tome također obezbjediti stručne kadrove za provođenje zadataka. Istovremeno država mora osigurati zadovoljavajući nivo suradnje, da se osigura potrebna usklađenost između zakonskih propisa i njihovog zakonodavnog ispunjenja. (Prešern 1998)

STANDARDIZACIJA: standardi su instrument za gospodarsko i industrijsko povezivanje (integriranje), koji se upotrebljavaju kao tehnička osnova za pomoć zakonodavstvu. Oni su tehnički dokumenti prihvaćeni na temelju suglasnosti. Navode opća pravila na osnovi kojih bi bio proizvod ili proizvodi uniformirani. Standard je neobavezan tehnički dokument, koji postaje obavezan u tehničkom propisu kojeg izda nadležno ministarstvo.

Skladni (harmonizirani) standardi su standardi koji su neophodno sadržani u smjernicama.

IZDAVANJE AKREDITIVA (AKREDITIRANJE): je stručni postupak, s kojim nacionalna služba za akreditiranje podjeljenom listinom za zastupanje formalno potvrđuje osposobljenost nekog organa za izvođenje opredjeljenih zadataka na području utvrđivanja sukladnosti. U postupak akreditiranja se može uključiti svaki laboratorij, koji izvodi razvrstavanja ili ispitivanja, te svaki organ za certifikate koji izvodi nadzor za potrebe izdavanja certifikata za proizvode i sisteme kakvoće.

IZDAVANJE CERTIFIKATA: izvode različiti organi i na taj način neposredno ili posredno utvrđuju sukladnost proizvoda na osnovi specifikacija. Organ za certifikate izvodi postupke koji su zasnovani na pravilima međunarodnih i nacionalnih sistema izdavanja certifikata. Ovlašten je za posebno područje u skladu sa zahtjevima izloženim u standardima SIST EN 45000. (Srna, 1996)

SADAŠNJE TEHNIČKO ZAKONODAVSTVO U REPUBLICI SLOVENIJI

Zakon o sredstvima za zaštitu bilja (ZFfS)

Zakon (ZFfS), koji je bio objavljen u Službenom listu RS, br. 11/01, propisuje u VI. poglavlju i 45. članku sljedeće:

U promet je dozvoljeno davati samo naprave s kojima je uz propisanu upotrebu osigurano neškodljivo nanošenje sredstava za zaštitu bilja, koji imaju certifikat o sukladnosti i koji ispunjavaju uvijete iz certifikata.

Proizvođač odnosno uvoznik mora prije puštanja u promet, na svoj zahtjev, pridobiti certifikat da naprava ispunjava propisane uvjete.

Propisi, koji se upotrebljavaju (do donošenja novih) za izvođenje ZFfS za područje naprava su sljedeći:

- pravilnik o pridobivanju certifikata o primjerenosti za naprave za nanošenje sredstava za zaštitu bilja (Službeni list RS, br. 37/01).
- pravilnik o sadržaju i načinu vođenja registra naprava, za tipove s pridobivenim certifikatom, koji su na redovitom pregledu bili uspješni odnosno neuspješni (Službeni list RS, br. 12/00)

- pravilnik o uslovima i postupcima, koje moraju ispunjavati i izvoditi ovlašteni nadzorni organi za redovito pregledavanje naprava za nanošenje sredstava za zaštitu bilja (Službeni list RS, št. 12/00).

Zakonodavstvo na području zdravlja i sigurnosti na poslu

Među zakone s područja zdravlja i sigurnosti koji uključuju i podzakonske propise spadaju:

- Zakon o sigurnosti cestovnog prometa (Službeni list RS, br. 30/98)
- Zakon o zdravlju i sigurnosti na poslu (Službeni list RS, br. 56/99)
- Zakon o šumama (Službeni list RS, br. 30/93)
- Zakon o poljoprivredi (Službeni list RS, br. 54/00)

Zakonodavstvo na području poljoprivrede, koje uključuje zdravlje i sigurnost na poslu je relativno dobro uređeno. Sadrži više zakonskih i podzakonskih propisa, koja uređuju sva područja poljoprivrede. Neki zakoni i odredbe će postati pravomoćne ulaskom Slovenije u EU (Evropsku zajednicu). Radi preglednosti navodimo samo bistvene, i to (Osnovno tehničko zakonodavstvo):

- Zakon o zdravlju i sigurnosti na poslu (ZVZD) Službeni list RS, br. 30/2000;

Citat iz zakona (2.članak, drugi stav), koji je neposredno vezan za poljoprivredu: Kao poslodavac se podrazumijeva i poljoprivrednik ili fizička osoba, koji sam ili sa članovima svojih gospodarstava odnosno obiteljskim članovima obavlja poljoprivrednu, dobitnu ili drugu djelatnost kao jedino ili glavno zanimanje i ne zapošljava druge osobe. Zakon sadrži pravilnik o načinu izrade izjave, koja se naziva: izjava o sigurnosti s ocjenom rizika na radnom mjestu.

Stupanje na snagu Zakona je navedeno u Službenom listu RS, br. 64/2001, citat: urediti zdravlje i sigurnost na poslu u skladu s odredbama toga zakona do 31.12. 2002.

- Odredba o sigurnosti strojeva; Službeni list RS, br. 52-2453/2000. Navodi pod nazivom 2.: Najznačajniji zdravstveni i sigurnosni zahtjevi za određene kategorije strojeva, točka 3.4.7.: Prijenos snage između stroja na vlastiti pogon (ili traktorom) i pratećeg stroja.

U prilogu odredba navodi: Najznačajnije zdravstvene i sigurnosne zahtjeve za sprečavanje posebnih opasnosti, ..., i uslove koji su potrebni za postavljanje znaka CE. Znak CE proizlazi iz izraza »Conformité Européenne« i predstavlja znak za europsku sukladnost. U Sloveniji nema zakonske osnove, koja bi propisivala, da moraju proizvođači svoj proizvod označiti s znakom CE. Pravomoćnost odredbe je navedena u 16. članku, pod nazivom Prethodne i konačne odredbe. Valjanost odredbi počinje s pristupanjem Republike Slovenije u Evropsku zajednicu ili priznanjem odgovarajućeg međunarodnog sporazuma sa Europskom zajednicom.

- Zakon o sigurnosti cestovnog prometa uređuje pravila javnog cestovnog prometa i uslove za učešće u cestovnom prometu. Za sudionike, koji se bave poljoprivredom ili šumarstvom taj se zakon primjenjuje odmah kada se uključe u promet na javnoj cesti. Za njih vrijede iste odredbe kao i za druge sudionike, osim kada sam zakon to drugačije precizira. Posebne odredbe vrijede za pridobivanje vozačke dozvole F

kategorije (traktori i traktorske prikolice). Kandidat se mora osposobiti za sigurno rukovanje traktorom i traktorskim priključcima.

Važan korak u smjeru zakonskog uređenja sigurnosti pri radu u poljoprivredi i šumarstvu, neovisno na status poljoprivrednog gospodarstva ili poljoprivrednika, uređuje ove godine donešeni Zakon o poljoprivredi, koji u 73. članku govori o osposobljenosti i uslovima za siguran rad s poljoprivrednom i šumarskom mehanizacijom. (Dolenšek, 2001)

Temeljno tehničko zakonodavstvo

U posredno zakonodavstvo na području sigurnosti i zdravlja spada: Temeljno tehničko zakonodavstvo u koje spadaju zakoni:

- Zakon o općoj sigurnosti proizvoda (Službeni list RS, br. 23/99)
- Zakon o tehničkim zahtjevima za proizvode i o utvrđivanju sukladnosti (Službeni list RS, br. 59/99),
- Zakon o standardizaciji (Službeni list RS, št. 59/99),
- Zakon o akreditiranju (Službeni list RS, št. 59/99).

Navedeni zakoni govore o proizvodu i propisuju uslove pod kojima se taj proizvod može pojaviti na tržištu. Uslovi obuhvaćaju zahtjeve prema proizvodu i istovremene postupke za utvrđivanje propisanih zahtjeva. Propisani zahtjevi se obično odnose na obezbjeđivanje slobodnog protoka proizvoda i njegove sukladnosti s najvažnijim zahtjevima za sigurnost i zdravlje. Nabrojane zakone nadopunjuju podzakonski akti, kao: Odredba o sigurnosti strojeva (Službeni list RS, br. 52/00). Posrednim zakonodavstvu se pridodaju i zakoni s područja zdravstvene i socijalne sigurnosti, te osiguranja. To zakonodavstvo, sa stajališta sigurnosti i zdravlja pri radu, dolazi do izraza naročito tada, kada se nesreća već dogodi (Medved, 1999).

TEHNIČKO ZAKONODAVSTVO, KOJE JE U PRIPREMI ZA PODRUČJE POLJOPRIVREDNIH I ŠUMARSKIH TRAKTORA

Od kada je Rimski ugovor postavio ciljeve za unutrašnje tržište, gdje se roba, kapital i usluge mogu slobodno kretati iz jedne države članice u drugu, posebna je pažnja namjenjena području motornih vozila. Tako je Opći program za otklanjanje tehničkih zapreka za trgovanje potaknuo potrebu za usklađivanje postupaka u Europskoj zajednici za homologiranje motornih vozila, prikolica, motornih vozila na dva ili tri kotača, te poljoprivrednih i šumarskih traktora na kotačima.

U veljači 1970 godine je u EU prihvaćena prva direktiva, direktiva vijeća 70/156/EGS o približavanju zakonodavstva država članica, koji se odnosi na homologiranje motornih vozila i njihovih prikolica, takozvana krovna direktiva.

U ožujku 1974 godine je bila prihvaćena druga krovna direktiva, koja se je odnosila na homologiranje poljoprivrednih i šumskih traktora: direktiva vijeća 74/150/EGS.

Sve do prosinca 1989 godine su morali proizvođači, koji su željeli prodavati motorna vozila u Europskoj zajednici pridobiti nacionalnu homologaciju od svake države članice (

pri tome su te upotrebljavale isključivo svoje vlastite sisteme homologiranja), koja je temeljila na postojećim pojedinim direktivama EU.

Postupak homologiranja traktora u EU kao cjelini se primjenjuje od siječnja 1990 godine, kada su bile prihvaćene sve direktive o potrebnim tehničkim zahtjevima.

Glavni cilj krovnih direktiva je bio organizirati sistem, putem kojeg bi proizvođač traktora, traktore sa pridobivenom homologacijom bez prepreka prodavao na zajedničkom Europskom tržištu i to bez dodatnih provjeravanja u svakoj od država (Bernik, 2001).

Pregled predviđenih tehničkih specifikacija (TVS), koje će uvesti pojedine direktive EU na području poljoprivrednih i šumarskih traktora u slovensko tehničko zakonodavstvo

- TSV 301 74/151 Određeni sastavni dijelovi i karakteristike
- TSV 302 74/152 Najveća brzina i prostor za teret
- TSV 303 74/346 Retrovizorska ogledala
- TSV 304 74/347 Vidno polje i brisači vjetrobranskog stakla
- TSV 305 75/321 Oprema za upravljanje stroja
- TSV 306 75/322 Elektromagnetna kompatibilnost
- TSV 307 76/432 Mehanizam za kočenje
- TSV 308 76/763 Sjedalo za putnike
- TSV 309 77/311 Buka
- TSV 310 77/536 Zaštitna konstrukcija pri prevrtanju
- TSV 311 77/537 Emisija nečistoća iz dizelskih motora
- TSV 312 78/764 Vozačevo sjedalo
- TSV 313 78/933 Ugrađivanje svjetlostne opreme
- TSV 314 79/532 Namještanje svjetlosnih naprava i svjetlosno signalnih naprava
- TSV 315 79/533 Priključna naprava za vuču traktora i prijenos za povratnu vožnju
- TSV 316 79/622 Zaštitne naprave za slučajeve prevrtanja (statički pokus)
- TSV 317 80/720 Radni prostor, prilaz do vozačevog mjesta, vrata i prozori
- TSV 318 86/297 Priključno vratilo i njegova zaštita
- TSV 319 86/298 Pozadi postavljene naprave za zaštitu kod traktora sa malim razmakom između kotača
- TSV 320 86/415 O podešavanju, namještanju, djelovanju i označavanju komandne ploče
- TSV 321 87/402 Zaštitne naprave, koje su namještene ispod vozačevog sjedala kod traktora sa malim razmakom između kotača
- TSV 322 89/173 Stakla i priključne mehaničke naprave

SADAŠNJE STANJE NA PODRUČJU ZDRAVLJA I SIGURNOSTI PRI RADU U POLJOPRIVREDI

Za nezgode pri radu s traktorom se smatraju nezgode, koje se dogode na površini izvan javnih prometnica. U zadnjim godinama se povećava broj nezgoda na radu i iznosi približno (\approx)70 % od ukupnih nezgoda (Levstek, 2001). Među nezgodama sa smrtnim posljedicama u Sloveniji je učešće poljoprivredno šumskih nezgoda 5% u privatnom sektoru poljoprivrede odnosno, $\frac{1}{4}$ više nego kod stalno zaposlenih u djelatnosti poljoprivrede i šumarstva. Sve nezgode su povezane s manjim i većim materijalnim posljedicama i u 90% slučajeva sa različitim tjelesnim ozljedama (Dolenšek, Medved, 2001). Nezgode u poljoprivredi se ne mogu uvijek pripisati samo trenutnim prilikama na poslu i osposobljenosti radnika. Pri osnovnim uzrocima nezgoda moramo uvažiti početni tehnički nivo izrade traktora i trenutno tehničko stanje traktora, koje je opet ovisno o početnom tehničkom stanju traktora.

Za promjene pri kupovini traktora različitih proizvođača po 1990 godini je najviše doprinjela promjenjena gospodarska politika, prije svega promijenjeno carinsko zakonodavstvo i ukidanje sporazumnog gospodarstva, zapadnoeuropski proizvodi nisu više bili carinski opterećeni. Skupina traktora (Univerzal, IMT, ...) koja je nekada prevladavala s 60% tržišnim udjelom je na tržištu najviše nazadovala (slika 1). Trendovi u kupovini traktora upućuju na uvijek veći udio zapadnoeuropskih proizvođača.

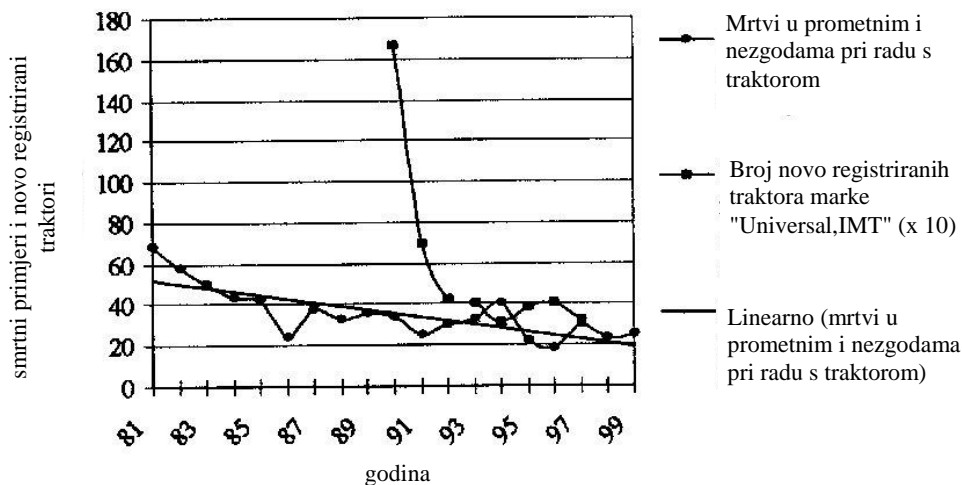

Slika 1. Usporedba novo registriranih traktora marke (Unverzal, IMT,...) s brojem smrtnih slučajeva pri nezgodama s traktorom (Levstek, 2001)

U Sloveniji je od 1981 godine računajući i 1999 godinu zbog posljedica prometnih i nezgoda pri radu s traktorom umrlo 672 ljudi (35,3 godišnje). Najmanje nezgoda pri radu s

traktorom je bilo u Sloveniji u 1996 godini (18), ali se je taj broj u 1997 godini opet povećao na 30. Po 1990 godini se broj smrtnih slučajeva u prometnim i nezgodama pri radu s traktorom smanjuje (slika 2). U promatranom razdoblju je bilo 60% mrtvih zbog prevrtanja traktora.

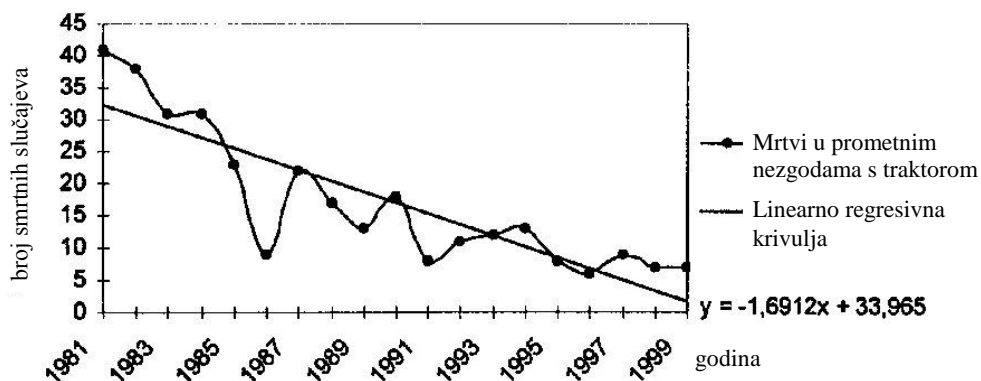

Slika 2. Mrtvi u prometnim nezgodama s traktorom u Sloveniji od 1981. do 1999. godine (Medved,1998)

Od 1981 godine pa do 1998 godine se je broj mrtvih pri nezgodama pri radu i prometnim nezgodama smanjio u prosjeku za 73,5%. (Šket, 2001)

Utjecaj zakonske regulative na smanjenje nesreća se je osjetio od 1984 godine, kada se je zahtjevalo obavezno namještanje kabine ili sigurnosnog luka na traktor. Broj nezgoda se je stvarno smanjio, ali ne do takve mjere, kao što bi očekivali, jer poljoprivrednici nisu opremili sve traktore s kabinama ili sigurnosnim lukovima.

U 1981 godini je bilo prosječno 12,1 mrtvih / 10.000 traktora, a u 1998 godini samo 1,7 mrtvih/ 10.000 traktora. Broj traktora se je u tom razdoblju jako povećao, istovremeno se je smanjio broj nesreća (Šket, 2001). Takvim kretanjima je sigurno pripomogao i zakonom obavezan 20 satni tečaj i ispit : "Sigurno rukovanje s traktorom i traktorskim priključcima", kojeg propisuje Zakon o sigurnosti cestovnog prometa.

ZAKLJUČAK

Slovenija je geografski, i u budućnosti i gospodarski, dio europskog prostora i zajedničkog tržišta država Europske zajednice. Svaka država članica EZ mora prije stupanja u zajednicu ispuniti brojne zahtjeve, između kojih spada i uređenje tehničkog zakonodavstva (Srna, 1995). U pojednostavljenom značenju ima tehničko zakonodavstvo u periodu pridruživanja na zajedničko tržište EU, za područje poljoprivredne tehnike cilj: uređivati, usklađivati i usmjeravati sljedeće:

- usporediti tehničke zahtjeve na proizvodu s jednakovrijednim proizvodom u EU ili izvan nacionalnog tržišta

- dizanje tehničkog nivoa izrade na usporediv nivo izrade tehničkih proizvoda u EU
- za korisnike poljoprivrednih strojeva pregledniju i sigurniju kupovinu, te siguran rad s njima
- zaštita i pomoć pri konstruiranju za domaće proizvođače strojeva, koji imaju viši nivo izrade pred stranom konkurencijom na tržištu,
- zaštita korisnika pred uvozom i puštanjem u promet proizvoda, koji ne odgovaraju usporednim međunarodnim ili nacionalnim zahtjevima izrade.

Problem prenošenja i primjene tehničkog zakonodavstva u praksi nije u izvođenju postupnih logističkih koraka, nego u malom interesu i istovremeno maloj proizvodnji domaće industrije u Sloveniji. U osnovi svakog tehničkog zakonodavstva mora biti proizvođač naprava onaj koji želi, odnosno zahtjeva tehničko zakonodavstvo, zbog toga da je na tržištu uvijek korak ispred strane konkurencije (Bernik, 2001). S takvim izvođenjem i izgradnjom tehničkog zakonodavstva je na tržištu uvijek prisutan kriterij tehničke dotjeranosti naprave i ne samo niska cijena naprave uz jeftine prodajne trikove.

LITERATURA

1. DOLENŠEK, M., MEDVED, M., (2001) Stanje na području varnosti in zdravja pri delu v zasebnem kmetijstvu in gozdarstvu, Simpozij: Trendi v razvoju kmetijske tehnike, str. 219-225.
2. GANZELMEIER, H., (1999) Pflanzenschutz-und Pflanzenplegetechnik. V: Jahrbuch Agrartechnik, 11, str. 83-92, Münster: Landwirtschaftsverlag,
3. LEVSTEK, T., (2001): Dejavniki zmanjševanja števila nezgod s traktorjem, Diplomsko delo, Biotehniška fakulteta, Oddelek za agronomijo.
4. MEDVED, M., (1998) Nezgode in tveganja pri poklicnem in nepoklicnem delu v gozdu; V Posvetovanje: varnost in zdravje pri gozdnem delu. Ljubljana, november 1998, str. 5-35.
5. PREŠERN, S., (1998) Harmonizacija zakonodaje, Nova proizvodnja, 49 letnik, 3/98.
6. SRNA, M., (1996) Varnost strojev in naprav na evropskih izkušnjah. /Milan Srna.-Mengeš: STILGRAF.
7. ŠKET, M., B., (2001) Nesreče s traktorjem in traktorskimi priključki po uvedbi tečajev; Simpozij: Trendi v razvoju kmetijske tehnike, str. 197-204.
8. Uradni list Republike Slovenije, (2000) Temeljna tehnična zakonodaja z uvodnimi pojasnili, Ljubljana.
9. Uradni list Republike Slovenije, št. 59-2794/99, Zakon o standardizaciji (Zsta-1).
10. Uradni list Republike Slovenije, št. 59-279679/99, Zakon o tehničnih zahtevah za proizvode in o ugotavljanju skladnosti (ZTZPUS).

STATE AND IMPLEMENTATION OF AGRICULTURAL LEGISLATION IN SLOVENIA

SUMMARY

Legislation, standardization and different structures for the estimation of product's accordance together with regulations and standards represent basic elements in quality system. Each good, which is in legal circulation in one of member states of European Union, must have the right for free circulation in all the regions of the United Market. Directives define production and marketing of goods in common market. The Act of Phytopharmaceutical Agents presents one of the more important acts from the field of environment protection and human health.

Key words: *European Market, technical legislation, safety, health*



GLOBAL TRACTOR DEVELOPMENT: PRODUCT FAMILIES AND TECHNOLOGY LEVELS

KARL TH. RENIUS

Technische Universität München (Campus Garching)
Fakultät für Maschinenwesen. Lehrstuhl für Landmaschinen
Garching, Germany.

SUMMARY

The paper first sums up the importance of the agricultural tractor for the general global economic development. Since the first mass production by Henry Ford 1917 the technical complexity of tractors has increased dramatically in two directions: Band width of power and band width of functions. It is not successful to design each model of a complete tractor line separately as the number of individual parts in relation to the number of models would exceed any economic limits. This leads to the product planning principle of segmenting tractor models into tractor families which is not new but often not well known. The segmentation is explained by the situation in Western Europe and by a proposal for developing countries like India or China. This 2nd example also deals to explain the principle of specific manufacturing costs.

Regarding the worldwide required tractor functions and economic conditions, a „high tech“ tractor line is often overspecified for developing countries. In order to assist product planning and tractor development mainly in these countries, the paper presents a classification of the worldwide used tractor technologies by proposing five technology levels. They are also suitable for the main tractor components which is demonstrated for the tractor transmission.

Key words: Tractor, product planning, agricultural mechanization, developing countries, technology levels, modular systems, technology transfer.

INTRODUCTION

The agricultural tractor is the most important machine for farm mechanization. About 40 to 45% of the total agricultural machinery investment is related to tractors in many

countries (Renius 1994). Successful tractor engineering needs professional product planning. This relatively new business technique has been highly developed in the automotive industry, initially mainly in the USA after World War II (Raviolo 1968).

Henry Ford launched his „Fordson“ tractor (Ford & Son) in 1917 and could achieve some years later more than 50% world market share with only one model due to the innovative and simple concept and due to low assembling costs of the (first) assembly-line for tractors. The principle of mass production in series is still valid but the „one-model“ philosophy has changed to a „multiple“ model strategy with a high number of options. Typical ranges of tractor power in Germany around 1970 have been described by Meyer (1970) as follows: 22-92 PS (Deutz), 22-90 PS (Fendt), 26-67 PS (IH), 28-80 PS (Eicher), 34-92 PS (Hanomag), 35-135 PS (Schlüter). 1 PS (rated engine power) = 0,7355 kW. Compared with the Fordson era, the number of functions had already been manifold at this time (Welschof 1974). Functions and power levels continued to increase in the recent 30 years in the high developed countries but in the same time the tractor technology in the lower developed countries did not grow with the same speed.

The variety of tractor models thus became very large and is still growing which complicates global and local strategies for both, mechanization and tractor development. Tractors which have been specified for countries with a highly developed agricultural mechanization are not suitable for countries with a lower level such as China, India, South America, Eastern Europe, Africa etc.. In addition to this, a local production of tractors is necessary in many of these countries because of the low tractor prices and the more or less high import tax rates. Nevertheless there is a need of a tractor technology transfer from the higher to the lower developed countries including fundamentals for the planning process of tractor lines and components and other related skills. The author sees a certain deficit in basic publications and local training in this field and would like to present some considerations based on experiences with national and international tractor projects.

TRACTOR TECHNOLOGY AND LIVING STANDARD

It can be regarded as a general law of political economy that any development of a nation towards a higher living standard needs in the first phase considerable improvements in agricultural mechanization replacing people by machinery (Fourastié 1954). The largest step forward can be achieved by the introduction of agricultural tractors (Heumann, Rapelius, Sievers, Weber 1980). In countries with smaller farms this is often started by the introduction of one-axle tractors, also „walking tractors“ or „power tillers“ (Sakai 1999) and lateron completed by two-axle tractors (Renius 1999) increasing again the level of productivity.

A typical example for this pattern of tractor introduction can be demonstrated by the development in Japan, table 1. The first tractors in the 1930s were only one-axle tractors. Almost another 30 years passed before two-axle tractors came up in the 1960s. The one-axle tractor fleet peaked with more than 3 million units in the 1970s, but afterwards diminished while the two-axle fleet continued to grow and could again double its volume until 1995. Other strategies are superior for agricultural structures with predominating larger farms, see the historical developments in North America and Western Europe.

Year	Tractor fleet in 1000 units	
	1-axle	2-axle
1937	1	–
1949	10	–
1955	82	–
1960	514	–
1964	2184	13
1968	3030	124
1972	3256	278
1976	3183	721
1980	2751	1472
1984	2842	1650
1988	2674	1985
1992	1786	2003
1995	1718	2313

Table 1. Tractors on farm in Japan 1937-95. Source: Japanese Ministry of Agriculture, Forestry and Fisheries (extracts see annual reports in AMA). Figures for 1992 may be a little bit too low according to comments from other sources

TRACTOR FAMILIES

The mechanization of an agricultural structure may start with a few tractor models but later on requires a whole tractor line which covers the entire tractor power levels and function profiles. The higher the mechanization level, the higher the number of required tractor models, variants and options. Tractors are mainly sold by engine or PTO power thus making the “nominal power” the predominating specification for both, the farmer and the manufacturer.

In most cases it is not economic, to develop only individual tractor models for the market demands as the number of tractor parts for a complete tractor line would become extremely high. Consequently the costs for development, purchase, stock, production, training, service and other overheads would exceed any economic limits. This leads to an important law of product planning (not only for tractors): *to keep the relation between the number of living parts and the number of produced models as low as possible* (Renius 1976).

This law requires tractor families. The principle is well known in the developed countries since several decades (Welschhof 1974) with originally major improvements by the tractor companies during the 1960s in Western Europe as well as in the US. Each tractor family consists of at least 2 models (in highly mechanized countries often 3 or 4). A typical tractor family pattern for Western Europe is presented by table 2 (model). The tractor line consists of 4 tractor families covering a range of 30 to 210 kW rated engine power.

In order to keep the number of parts low, there are several identical dimensions, parts or components used within each family such as one basic engine structure (uniform number of cylinders, common outside dimensions and engine interfaces), a common transmission family, one wheel base, one front support or frame, one basic set of sheet metal, one basic

cab structure and working place layout, one basic electrical system, one basic electronic system, one basic hydraulic system, one basic fuel tank, common interface specifications for implements, common options, one service manual, a common catalog of parts etc..

Table 2. Pattern of the basic specifications of a typical Western Europe tractor line 2002, which consists of at least 4 tractor families (model of the author).

Tractor family	1	2	3	4
Rated engine kW	30 – 55	60 – 90	90 – 125	135 – 210
Market trend (units)	↘	⇒	↗	↗
Number of functions	moderate	high	very high	
Diesel engine	3 cylinder, ~ 3 l	4 cylinder, ~ 4 l	6 cylinder, ~ 6 l	6 cylinder, > 7 l
Gear box	Synchro-mesh with reverser. Hi-Lo or L-M-H power shift opt. CVT studies	Synchronized ranges, 3 or 4 speeds and reverser power shifted		Full power shift including reverse
			Full power shift opt.	
		Continuously variable transmissions (CVT) upcoming Automatic shift functions upcoming for all transmissions		
	Top speeds: EU 40 km/h, Germany optional 50 km/h (Fendt 1993)			
Axle concepts (FWD dominant)	Total axle speed reduction: 30–40 (rear axle), 15–25 (front axle). Planetary final drives, wet disc brakes. Automatic shift and hydropn. suspensions upcoming			

The very important benefits of the family principle are balanced by one important conflict, which addresses the manufacturing costs. Fig.1 illustrates nominal power and specific costs of a simple tractor line. There are 3 families with a total of 7 models which are marked by small circles representing the specific manufacturing costs (costs per unit of nominal tractor power) in linear scale versus the nominal tractor power in logarithmic scale. This principle is derived from a published proposal (Welschof 1974) – similar procedures are usual for product planning activities in well working tractor companies (Jenkins, 1997). The author prefers a logarithmic power scale instead of a linear one with the advantage, that every power ratio is represented by a geometrical length.

A typical power ratio for neighboring tractor models is around 1,1 in high technology markets for the most popular power range and above 1,1 for the less popular power ranges of the same market place. The general level of these power ratios is higher for developing countries. Three tractor families are regarded in fig.1 – this could be a typical proposal for planning a tractor line for China or India.

The lowest specific tractor costs are always found for the largest model of a family as the potential of all components is best used in this case. As several parts or components are also common for all models, the specific costs must increase with a reduced nominal power. In order to be competitive in tractor first costs, this effect should be compensated as much as possible by reducing the costs of those components which are power-related by their dimensions and other design parameters or by market needs.

Engine costs can be adjusted to the power level by 3 versions of charging in connection with adequate “inner” dimensions, materials and coolers: Natural aspiration, turbo charging, turbo charging with intercooler (see also example on page 138 of Renius 1999).

Further cost adjustments are possible by the rated engine speed, by bore and stroke and by the technical equipment for engine control. Other typical potential of a power-related cost adjustment can be seen in the standard equipment of the transmission, the size of the tractor axles, the tire dimensions, the performance of the power lift, the flow rate of the hydraulic system and comfort functions for the driver such as synchronized shift instead of power shift or manual steering instead of power steering etc.

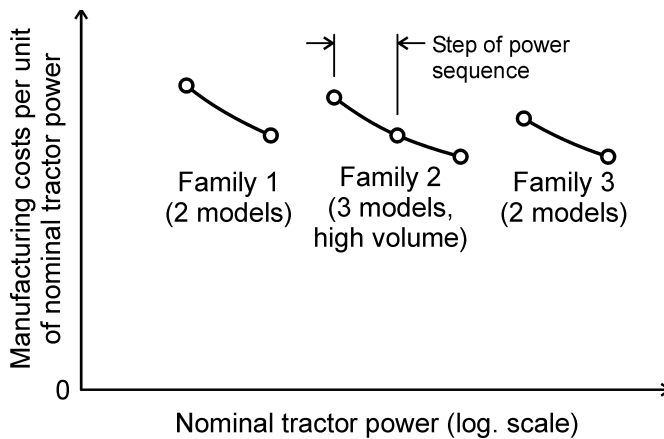

Figure 1. Structure and specific manufacturing costs for a simple tractor line which is formed by 3 tractor families (in principle after Welschof 1974)

In spite of all these possibilities of cost adjustment within a tractor family the smallest model will always remain the critical one in specific costs while the largest is usually most cost effective. Economic evaluations over all models of a tractor family can compensate for this disparity. If the general cost level remains too high (promising poor profit), tools and techniques of “value engineering” can be applied (early review paper see Schwarz 1968). Many successful tractor lines confirm the experience, that the family strategy is superior to the principle of individual models.

TECHNOLOGY LEVELS OF TWO-AXLE TRACTORS

Based on a long lasting experience in tractor engineering with international activities the author proposes to classify the present worldwide used tractor technologies into five levels, table 3.

Table 3. Basic specifications of tractors by technology levels: worldwide view for two-axle tractors. ROPS means “Roll-Over Protective Structure”.

Technology level	Nominal engine power			Wheel drive			Diesel engine					Drive transmission				PTO		Hydraulics			Cab			Electronics					
	Low	Medium (40–80 kW)	High	Only rear-wheel drive	Four-wheel drive opt.	Four-wheel drive stand.	1 Cylinder	2 Cylinder	3 Cylinder	4 Cylinder	6 Cylinder	Very simple	Simple	Partial power shift	Full power shift	Infinitely variable	540/min	540 and 1000/min	3 or 4 speeds	Rear 3-point hitch	Remote Control	Rear & front 3-p. hitch	Load Sensing circuit	No cab	ROPS / low cost cab	Comfort cab	Not existing	Low cost concepts	High tech concepts
I	X			X			X	X		X	X					X			X				X						X
II	X	X			X			X	X	X	X		X				X		X	X			X	(X)			X	(X)	
III		X	(X)	(X)	X			X	X	X			X			(X)	X		X	X	X			X	(X)		X	(X)	
IV		X	X		X			(X)	X	X			X	X				X	X	X	X	X			X			X	
V		X	X		X				X	X					X			X	X	X	X	X			X			X	

The term „technology level“ shall address the level of tractor functions and technical complexity: I represents the lowest and V the highest technology level. The not mentioned levels of required reliability and durability are not corresponding with this pattern – it even happens in some market places, that a tractor of a low technology level must offer an outstanding durability in connection with untrained driver, high air temperatures, heavy soils or paddy fields and poor service.

The lowest technology level I is characterized by a low power level, only rear wheel drive, low comfort, low overturning safety (typically no ROPS) and very simple components. This level I is typical for the predominating tractor population in China (small two-axle tractors) and similar regions. This level was also found in India in the past for a longer period of time but is now moving towards level II in this country. The author would like to mention as an example for this trend in India a new tractor line, which has been developed with some interesting principles of technology transfer and international cooperation (Firodia, Bacher, Renius, 1999).

Level IV addresses the typical modern tractor in highly developed regions like Mid Europe, North America, Japan and others. The specification pattern of this level is however not in any case the same for all tractor families of a complete line: The family 1 of the presented model for Western Europe (see table 2) would rather be covered by technology level III than by IV. On the other hand there is an upcoming level V for these market places, mainly characterized by infinitely variable transmissions and updated diesel engines – both with electronic control systems and common automatic control strategies, also called “drive line management”.

TECHNOLOGY LEVELS FOR TRACTOR COMPONENTS

The principle of the definition of technology levels can also be applied for tractor components. The transmission can be called to be most important in terms of first cost, mostly also in terms of development costs.

The tractor transmission consists mainly of the speed change and reverser box, the final drive with the service brakes, the four-wheel drive arrangements and the PTO drive line including often auxiliary drives such as the main hydraulic pump. The most important differences regarding technology levels can be found in the speed change concept, table 4. This pattern is picked up from a review paper of the author on worldwide tractor transmissions of all levels listing important concepts and explaining typical structures by transmission maps (Renius 2000).

Table 4. Technology levels for tractor transmissions (concentrated on the speed change and the reverser functions). SG: Sliding Gear shift, CS: Collar Shift, SS: Synchronised Shift, HiLo: 2-speed power shift, PPS: Partial Power Shift (3 or more speeds), FPS: Full Power Shift (all speeds), CVT: Continuously Variable Transmission, () options

Technology level	Typical drive transmission specifications			
	Nominal speeds, km/h forward	reverse	No. of speeds forw. / rev.	Shift elements
I	2–20(25)	3–8	6/2 to 8/2	SG+CS
II	2–30	3–10	8/4 to 12/4	CS+SS
III	(0.5)2–30(40)	3–15	12/4 to 16/8	SS+HiLo
IV	(0.3)2–40(50)	2–20	16/12 to 36/36 (or more)	SS+PPS, FPS
V	0–50(65?)	0–30	infinite	CVT+SS

The most simple gear box of level I offers only 6 forward and 2 reverse speeds and the shift is only done by sliding gears or collar elements covering a relatively small speed span. This technology was typical for Western Europe and North America around 1950 and became later important for several developing countries, among which India plays an important role. Right now the Indian market requirements move towards level II. The transmission of the mentioned tractor project (Firodia, Bacher, Renius 1999) is a ZF-based 8/4 concept (A 212) with synchronized 4 basic speeds and a mixture of collar shift and sliding gear shift for the ranges (Renius 2000). It has an extra large master clutch, 2 PTO speeds, high performance life time wet disc brakes and an extra strong final drive.

Level III is typical for smaller tractors in higher developed countries while level IV represents the typical popular concept in these countries since now several years (Renius 2000). There is again an increase in technology when we move to level V representing infinitely variable transmissions (CVTs) of a new high sophisticated generation. They offer

considerably higher efficiencies and more automatic functions than realized ever before for CVTs. Compared with conventional hydrostatic units such as used for Japanese tractor transmissions, the energy losses of the mentioned new CVT units (without final drive) are only about half due to the power split principle and optimized or completely new axial piston units. The first transmission of level V was presented by Fendt 1995 and produced in series since 1996 (Renius 1999). Meanwhile CLAAS, STEYR, ZF and J. Deere have introduced similar concepts (status end of 2001). The outstanding efficiencies are only a very little bit below those for level IV transmissions (Renius 1999).

CONCLUSIONS

A worldwide acting tractor company has to minimize the number of living parts segmenting a complete tractor line into families. Such a manufacturer will be able to cover the technology levels IV and V with no major problems but it will already be very difficult, to combine the technology levels III, IV and V in one tractor family. There are no chances to also include the technology levels II and I which are typical for developing countries like India or China. These nations should therefore look for technology transfer strategies based on proved tractor designs of the levels I, II and III working in the same time with updated product planning principles. The experience with the mentioned Indian tractor project shows, that it is not economic to copy an older tractor model from the industrialized countries 1:1 by a license contract for the complete tractor. It seems to be more successful to use license contracts only for specific components while the general tractor concept and the component details are derived from the local market needs and also tested according to the typical loads under local tractor service conditions.

Product planning, concept finding, engineering, testing and service training can considerably be supported by experts and engineering companies from the developed countries.

REFERENCES

1. FIRODIA, A., BACHER, R., RENIUS, K. T., (1999) Transfer of technologies from developed to developing countries: experiences and results in Asia and the Far-East. The Case of India. Club of Bologna 10th meeting 14-15 November. UNACOMA, Rome.
2. FOURASTIÉ, J., (1954) *La Productivité*. Paris.
3. HEUMANN, G., RAPELIUS, M., SIEVERS, M., WEBER, A., (1980) *Die Schleppernachfrage in einzelnen Regionen der Welt (The demand for agricultural tractors worldwide)*. Agrarwirtschaft Vol. 29, No. 5, 129-141. Deutscher Fachverlag, Frankfurt/ Main.
4. MEYER, H., (1970) *Fünfundzwanzig Jahre Ackerschlepperbau (Twenty five years review on tractor engineering)*. Landtechnik Vol. 25, No. 5, 118, 120-122, 124-128.
5. RAVIOLO, V.G., (1968) *Planning a Product*. The Fourteenth L. Ray Buckendale Lecture. Society of Automotive Engineers, paper SP-341, New York, N.Y., USA.
6. RENIUS, K.T., (1976) *Lectures on tractor engineering*. Professorship at RWTH Aachen, official appointment summer semester 1976-82.

7. RENIUS, K.T., (1994) Trends in Tractor Design with Particular Reference to Europe. *Journal of Agricultural Engineering Research*, Vol. 57, No. 1, 3-22.
8. RENIUS, K.T., (1999) Two Axle Tractors. In: *CIGR Handbook of Agricultural Engineering*, Vol. III, p. 115-184. American Society of Agricultural Engineers, St. Joseph MI., USA.
9. RENIUS, K.T., (2000) Trends in tractor transmission development. Seminar 14 November at „ICAME 2000“ 13-16 November 2000 Seoul, Convention and Exhibition Center (COEX). Korea Agricultural Machinery Industry Cooperative, Seoul.
10. SAKAI, J., (1999) Two-Wheel Tractor Engineering (bilingual jap./engl.). Shin-Norinsha Co. Ltd., Tokyo.
11. SCHWARZ, F.C., (1968) Managing progress through value engineering. SAE paper No. 680566. Society of Automotive Engineers, New York, N.Y., USA.
12. WELSCHOF, G., (1974) Entwicklungslinien im Schlepperbau. Kriterien für die heutige und zukünftige Entwicklung (Development lines of tractor engineering. Criteria for the present and future development). *Grundlagen der Landtechnik* Vol. 24, No. 1, 6-13. VDI-Verlag Düsseldorf, Germany.
13. JENKINS, G.W., (1997) Principles of Product Planning for Worldwide Design. ASAE Distinguished Lecture Series. Tractor Design No. 21 American Society of Agricultural Engineers, St. Joseph, Mi., USA.



DIJAGNOSTICIRANJE KARAKTERISTIKA DIESEL MOTORA PRIMJENOM DIESELSKOG I BODIESELSKOG GORIVA

KRALJEVIĆ, D., EMERT, R., JURIĆ, T

Poljoprivredni fakultet Osijek, Zavod za poljoprivrednu mehanizaciju
Vinkovci, Hrvatska

SAŽETAK

Goriva mineralnog porijekla su ograničenih rezervi. Slijedeći veliki problem je onečišćenja okoliša, posebno atmosfere s produktima izgaranja. Iz navedenih te drugih razloga, intenzivno se iznalaze alternativni i po mogućnosti obnovljivi izvori energije u cijelom svijetu.

Europa se većim dijelom, zbog niza pogodnosti opredjelila za proizvodnju, između ostalog i biodieselskog goriva. Budući i Hrvatska ima slične agroklimatske uvjete i kod nas je pokrenut projekt za proizvodnju i eksploataciju biodieselskog goriva kao i u Europi, poglavito iz uljane repice pri čemu se mogu koristiti i organska otpadna ulja.

Nekoliko je bitnih pretpostavki koje su nezaobilazne u takvom ciklusu, a to su:

- zainteresirati na bazi ekonomskih pokazatelja ratare za povećanu proizvodnju uljane repice,*
- osigurati tehnologiju prerade biodieselskog goriva i*
- uvjeriti mehanizatore i ostale korisnike na bazi pouzdanih dijagnostičkih ispitivanja o prednostima korištenja biodieselskog goriva.*

U ovom radu se iznose rezultati istraživanja prilikom upotrebe biodieselskog goriva kod diesel motora u poljoprivrednoj mehanizaciji.

Ključne riječi: *dijagnostika, biodieselsko gorivo, motori, poljoprivredna mehanizacija*

UVOD

U posljednjoj dekadi je izuzetno velika ponuda novih tehnoloških rješenja koja bi trebala osigurati tržišno konkurentnu poljoprivrednu proizvodnju. Korisnici su jednostavno "zasuti" u kratkom vremenu ogromnom ponudom kako poznatih tako i novih tehnoloških rješenja koja vrlo često nisu na potrebnoj razini kvalitete (UFOP, 1998., UFOP 2001.) Budući se i upotreba biodieselskog goriva priprema kao novina na našem području, to je potrebno temeljito, stručno i argumentirano potencijalnim korisnicima ponuditi što više podataka u eksploatacijskim uvjetima na našem području (Krička, 1999., Katić, 2000.).

Uspoređujući cijenu sirove nafte u svijetu te paralelno povećanje proizvodnje drugih vrsta goriva, a posebno onih izvora koji su obnovljivi, smatra se kako je nerealno očekivati razvoj novih konstrukcija motora za nova goriva, nego treba nastojati barem u prvom razdoblju, prilagoditi nova goriva postojećim konstrukcijama motora (Furman, 1995.).

Iskustva nekih europskih zemalja u primjeni biodieselskog goriva u usporedbi sa klasičnim dieselskim gorivom ukazuju na značajno smanjenje emisije štetnih tvari u ispušnim plinovima motora (Filipović i sur., 1999.).

Dijagnostika se zasniva na provjerenim pokusnim metodama i uzajamnoj svrhovitoj zavisnosti izmjerenih parametara (Emert i sur. 1995.).

Kod ranijih istraživanja karakteristika motora elektro-mehaničkim ili hidrauličkim kočnicama, puno se vremena utroši na samu pripremu mjerenja, te matematičku obradu rezultata.

Zbog navedenih razloga, obavljena su brojna istraživanja na diesel motorima sa različitim postocima biodieselskog goriva.

METODE ISTRAŽIVANJA

Istraživanja su provedena na traktorskom diesel motoru tipa M 33/T-LP. Usporedna istraživanja obavljena su sa tri tipa goriva. Prvo je korišteno klasično diesel gorivo, nakon čega je otvaran motor. Obavljena je vizualna kontrola, promjenjene brtve te je motor očišćen od prethodnih naslaga. Drugo gorivo je bila od mješavine 30 % biodieselskog i 70 % dieselskog goriva. Nakon drugog ispitivanja je ponovno očišćen motor i zamjenjene brtve. U trećem mjerenju je korišteno 100 % biodieselsko gorivo. Provedena istraživanja obavljena su u svrhu utvrđivanja snage, okretnog momenta motora i specifične potrošnje goriva pri uporabi određenih postotaka biodieselskog goriva odnosno čistog biodiesela. Daljnja istraživanja su usmjerena utvrđivanju utjecaja biodieselskog goriva na gumene dijelove motora, sastav ispušnih plinova te trošenje pojedinih dijelova motora.

REZULTATI ISTRAŽIVANJA

Dijagnosticiranje se obavljalo pomoću suvremene dijagnostičke opreme AVL 845. Ovi kompjutorizirani uređaji se priključuju na motore bez demontaže dijelova, jednostavnim spajanjem vrlo osjetljivih piezoelektričkih elemenata i ostalih osjetila. Na ovaj način se izbjegavaju eventualne pogreške karakteristične za slična mjerenja, ljudski čimbenik

pogreške je sveden na minimum, a proces je znatno ubrzan. Ono što je značajno za ovaj oblik dijagnosticiranja stanja motora jest da nema otvaranja motora i time ponovnog ugrađivanja novih dijelova (brtvi i slično).

Rezultati istraživanja ukazuju da nema značajnije promjene snage motora pri primjeni navedene tri vrste goriva, tablica 1.

Tablica 1. Rezultati mjerenja snage motora

Redni broj ispitivanja	1	2	3	4	5	6	7
Broj okr.motora (°/min)	1000	1200	1400	1600	1800	2000	2200
Snaga motora primjenom diesela (kW)	15,08	18,26	20,55	23,05	25,85	28,50	31,00
Snaga motora sa 30 % biodiz.i 70% diesela (kW)	15,05	18,16	20,45	22,88	25,74	28,38	29,95
Snaga motora primjenom biodiesela (kW)	15,00	18,05	20,30	22,80	25,66	28,20	29,80

Rezultati mjerenja okretnog momenta motora ukazuju na blagi pad momenta pri povećanom broju okretaja motora, a pri korištenju čistog biodieselskog goriva, tablica 2.

Tablica 2. Rezultati mjerenja okretnog momenta

Okretni moment	Nm						
Red.br.ispiti.	1	2	3	4	5	6	7
Broj okretaja motora (°/min)	1000	1200	1400	1600	1800	2000	2200
Primjena diesela (100%)	144,20	144,30	143,98	143,18	142,50	140,20	126,70
30% biodiesela 70% diesela	144,14	144,22	143,80	143,00	142,30	139,50	126,30
Biodiesel (100%)	144,05	143,90	143,10	142,70	141,75	133,80	125,25

Rezultati ispitivanja specifične potrošnje goriva pokazuju kontinuiranu povećanu potrošnju biodieselskog goriva u odnosu na rad motora s klasičnim gorivom, tablica 3.

Tablica 3. Rezultati mjerenja specifične potrošnje goriva

Spec. potroš. goriva	g/kWh						
Red.br.ispiti.	1	2	3	4	5	6	7
Broj okretaja motora (°/min)	1000	1200	1400	1600	1800	2000	2200
Primjena diesela (100%)	278,00	275,10	274,25	273,50	273,90	274,50	291,90
30% biodiesela 70% diesela	277,00	276,80	276,20	275,05	275,45	277,15	296,80
Biodiesel (100%)	283,10	282,45	284,10	285,65	285,85	288,90	308,90

ZAKLJUČAK

U prvom razdoblju istraživanja karakteristika diesel motora primjenom mješavine dieselskog i biodieselskog goriva, te čistog dieselskog i biodieselskog goriva posebna pažnja je posvećena najvažnijim karakteristikama motora, snazi, okretnom momentu i specifičnoj potrošnji goriva.

Iz mjerenih karakteristika veličine snage, okretnog momenta te specifične potrošnje goriva pri primjeni čistog biodiesela, vidimo da odstupanja nisu velika obzirom na diesel gorivo.

Rezultati ovih mjerenja pokazuju sukladnost sa inozemnim podacima, a u sveukupnom kontekstu ukazuju na ekonomsko – ekološku opravdanost upotrebu biodiesel goriva.

LITERATURA

- EMERT, R. i sur.(1995), Održavanje traktora i poljoprivrednih strojeva, udžbenik, Osijek.
- FURMAN, T. i sur.(1995): Biodiesel – proizvodnja i korištenje, Novi Sad.
- KATIĆ, Z. (2000): Biodiesel – izlaz iz krize u poljoprivredi, Gospodarski list br. 39, Zagreb.
- KRIČKA, T., DOMAC, J., JUKIĆ, Ž. (1999): Odrednice proizvodnje biodiesel goriva u Hrvatskoj, časopis "Nafta".
- TOMIĆ, B. (1982) : Tehničke mogućnosti ekonomske i društvene cjelishodnosti supstitucije diesel goriva biljnim uljima, Goriva i maziva, Savez društava za primjenu goriva i maziva Jugoslavije, Zagreb 21(1982) 2, 95-103
- UFOP – Schriften, (1998) Rapsöl.
- UFOP- Aktuell, (2001), Biodiesel-Argumente die zahlen, Bonn.

DIAGNOSIS OF THE CHARACTERISTICS OF A DIESEL ENGINE USING DIESEL AND BIODIESEL FUEL

SUMMARY

Mineral fuels can be found in only limited resources. The next big problem is the environment pollution, especially the pollution of the atmosphere by exhaust products. Based on the above mentioned an intensive research into the alternative and if possible renewable energy resources has been conducted.

Europe has mostly turned to biodiesel production because of many favours. Since Croatia has similar agro-climatic conditions we have also started a project for the biodiesel production and exploitation as in Europe, especially from oil rape from which also organic waste oils can be used.

There are some important assumptions which are unavoidable in this process and they are as follows:

- farmers should be interested in increasing this production based on financial factors*
- the technology for biodiesel production should be provided*
- the users of this fuel have to be reassured based on safe diagnostic factors that this usage has its favourable characteristics*

This work provides the research results when using biodiesel fuel by diesel engines in the agricultural mechanization.

Key words: *diagnosis, biodiesel fuel, engines, agricultural mechanization*



RAZVOJ MJERNE OPREME ZA TRAKTOR AGT 835

VIKTOR JEJČIČ¹, ANTON ŠTERN², TOMAŽ POJE³
IGOR KOVAČEV⁴, KREŠIMIR ČOPEC⁵

Kmetijski Inštitut Slovenije, Oddelek za kmetijsko tehniko, Ljubljana^{1,3}
Srednja šola kmetijske mehanizacije, Maribor²
Sveučilište u Zagrebu, Agronomski fakultet, Zavod za mehanizaciju, Zagreb^{4,5}

SAŽETAK

Za potrebe istraživanja traktora AGT 835 sa mehaničkom i hidromehaničkom transmisijom u radu u realnim uvjetima, razvijena je posebna mjerna oprema. Mjerna oprema omogućava istovremeno mjerenje okretnog momenta na osovini kotača, dinamičke sile na kotaču, broja okretaja kotača, prijeđeni put, okretni moment motora, broj okretaja motora, okretni moment na priključnom vratilu te broj okretaja priključnog vratila. Istovremeno je omogućeno i mjerenje trenutnog uzdužnog i poprečnog nagiba traktora na terenu razgibanog reljefa. Pomoću mjerne opreme ustanovljena je potrošnja energije traktora u radu sa različitim priključcima.

Ključne riječi: traktorska tehnika, mjerna oprema, električno mjerenje mehaničkih veličina na traktoru

UVOD

U traktorskoj tehnici pored standardnih i specijalnih traktora ima svoje mjesto i segment traktora sa izodiametralnim kotačima (svi kotači jednakog promjera), pogonom 4 x 4, niskim klirensom, manjim dimenzijama i masom te snagom motora do 50 kW. Taj segment traktora namijenjen je za rad na manjim površinama odnosno na terenima gdje je posebno otežana odnosno nemoguća upotreba standardnog traktora (npr. veliki nagibi terena). Susrećemo ih u radu u brdsko planinskom području Europe a posebice npr. u Austriji, Švicarskoj, Italiji, Sloveniji itd. Pored svoje osnovne funkcije sa stanovitim adaptacijama ti traktori su prikladni i za šumarstvo, komunalnu namjenu, hortikulturu itd. Taj segment traktorske tehnike pokriva u Europi veliki broj proizvođača kao npr. Antonio Carraro, Goldoni, Holder, Landini, Pasquali, BCS, Ferrari, Hieble itd.

Početak devedesetih godina prošlog stoljeća počela je Agromehanika Kranj proizvoditi traktor AGT opremljen motorima snage od 13,2 kW do 26,4 kW sa izodijametralnim kotačima i pogonom 4 x 4. Traktor je koncipiran za upotrebu na malim poljodjelskim površinama te terenima gdje je otežana ili čak nemoguća upotreba standardnih traktora. Namijenjen je i za rad u voćarstvu, vinogradarstvu, vrtlarstvu, komunalni itd. Pored zglobne ponudena je i varijanta sa upravljanjem preko prednjih kotača. Traktori imaju mehaničku ili hidromehaničku transmisiju. Za potrebe daljnjeg razvoja potrebno je bilo analizirati traktor AGT 835 u radu kao i posebice radu na nagnutim terenima, stoga je razvijena specijalna mjerna oprema koja je omogućila istovremeno ustanovljavanje različitih mehaničkih veličina na traktoru u radu. Pomoću utvrđenih mehaničkih veličina moguće je utvrditi potrošnju energije traktora, stupanj oštećenja radne podloge, stupanj korisnog djelovanja transmisije, opterećenost transmisije itd.

PREGLED LITERATURE

(Tompkins et al) konstatiraju da je zbog adekvatnog izbora priključaka kao i operacija sa traktorskim priključcima te potrebe po smanjenju potrošnje energije u biljnoj proizvodnji zbog narastajućih troškova proizvodnje, potrebno raspolagati sa podacima o potrošnji energije različitih traktorskih priključaka na različitim tipovima tla kod različitog fizikalnog stanja tla. Autori isto tako konstatiraju da oprema koja je dotada bila razvijena omogućavala je mjerenje samo nekih mehaničkih veličina koje su potrebne za ustanovljavanje inputa energije. Stoga su preuredili standardni traktor sa pogonom na zadnje kotače za mjerenje potrošnje energije traktora u radu različitim priključcima. Na zadnjim kotačima traktora preparirali su osovine kotača sa naljepljenim elektro otpornim mjernim listićima (tenzometri), u središte osovine kotača namjestili su klizne kontakte za napajanje električnom energijom a na obod osovine kotača zupčanik sa magnetskim senzorom impulsa. Za mjerenje prijeđenog puta služio je kotač sa zupčanikom (“peti kotač”) sa magnetskim senzorom impulsa. Na trozglobnu poteznicu namjestili su dinamometarski okvir za mjerenje sila. Pored ostaloga namjestili su i senzor za mjerenje potrošnje goriva. Instrumenti su bili povezani sa pojačalom i računalom u krovu kabine. Autori konstatiraju da je kotač za mjerenje prijeđenog puta zbog malog oboda i relativno slabe pritisne sile na tlo djelovao sa većom pogreškom na izrazitom mikroreljefu terena.

Nedostatak spomenutog mjernog sistema je bio u tome što autori nisu mogli pratiti neke vrlo važne parametre kao npr. okretni moment motora, broj okretaja motora te okretni moment i broj okretaja na priključnom vratilu traktora (imali su mogućnost mjerenja samo sa pasivnim traktorskim priključcima). Pored toga njihov kotač za prijeđeni put bio je neprikladan za rad u poljskim uvjetima npr. na izoranome tlu, tako da je greška u radu bila velika. Pojačala i računarska tehnika koji su tada bili upotrijebljeni omogućavali su akviziciju malog broja podataka odnosno vršenje mjerenja kod niskih frekvencija uzimanja uzoraka iz mjernog signala. (Grevis et al) razvili su opremu za potrebe istraživanja na traktorima kao i priključnim strojevima u svrhu pravilnog izbora traktora i priključaka glede potrebne snage. Njihova oprema omogućavala je mjerenje brzine kretanja traktora, klizanje kotača i vučnu silu. Iz dobivenih podataka izračunavana je potrebna snaga za pogon priključaka odnosno potrebna snaga za rad traktora. Njihov mjerni sistem imao je

samo mogućnost direktnog očitavanja bez pohrane podataka a problem je bio i mala točnost mjernog sistema.

MATERIJAL I METODA RADA

Za eksperiment su uzeta dva traktora AGT 835, jedan sa mehaničkom i drugi sa hidromehaničkom transmisijom. Traktori su bili jednakih dimenzija i mase sa izodijametričkim kotačima kao i jednakim pneumaticima. Bili su opremljeni vodeno hlađenim, trocilindričnim dieselskim motorom, snage 26,4 kW. Traktor sa mehaničkom transmisijom bio je opremljen nesinhroniziranim mjenjačem koji ima 6 stupnjeva prijenosa za gibanje naprijed i 3 za gibanje natrag. Hidromehanička transmisija kod drugog traktora ima 3 osnovna mehanička stupnja prijenosa a unutar svakog mehaničkog stupnja prijenosa moguće je kontinuirano varirati prijenosni odnos odnosno izabrati teoretski beskonačno mnogo brzina gibanja traktora od 0 – max. Maksimalna brzina gibanja kod oba traktora iznosila je 21,8 km/h.

Oba eksperimentalna traktora opremljena su jednakom mjernom opremom. Na traktore su montirani dinamometri: za mjerenje okretnog momenta kotača, sile na kotaču, okretnog momenta na priključnom vratilu te okretnog momenta na izlazu iz motora odnosno ulazu u traktorsku transmisiju. Za mjerenje broja okretaja kotača i prijednog puta upotrijebljeni su inkrementalni davači impulsa. Za mjerenje broja okretaja motora upotrijebljen je induktivni senzor. Uzdužni i poprečni nagib traktora u radu u strmini mjeren je pomoću induktivnih senzora.

Na poluosovine traktora pričvršćeni su dinamometri vlastite konstrukcije. Dinamometri su bili namijenjeni istovremenom mjerenju okretnog momenta pojedinog kotača te dinamičkog prenošenja sila (težine) na poluosovinu pojedinog kotača pri gibanju traktora po razgibanom terenu. Svaki dinamometar je imao zalijepljene elektro odporne mjerne listiće namijenjene mjerenju torzije (okretni moment) i savijenosti (dinamički prijenos sile na kotač) dinamometra. U središtu osovine kotača bili su pričvršćeni na svakom kotaču posebni inkrementalni davači broja impulsa koji su omogućavali brojanje impulsa (za jedan puni okretaj kotača dobiveno je 100 impulsa) pri gibanju kotača naprijed i natrag. Spomenuti davači omogućavali su brojanje naprijed ili natrag tako da je bilo moguće razlikovati u kojem smjeru se je gibao traktor. Iz broja okretaja kotača te prijednog puta izračunato je klizanje za svaki kotač posebno. Isto tako u središtu osovine svakog kotača bili su namješteni i klizni prstenovi vlastite konstrukcije, namijenjeni električnom napajanju dinamometra za okretni moment i dinamički prijenos sile na kotač kao i prijenos izmjerenog signala do pojačala signala. Na izlazu iz motora i ulazu u transmisiju (traktor sa hidromehaničkom transmisijom), odstranjena je sklopka. Na njeno mjesto učvršćen je dinamometar sa kliznim prstenovima vlastite konstrukcije, namijenjen mjerenju okretnog momenta motora. Broj okretaja motora mjeren je pomoću induktivnog senzora impulsa, namještenoga pokraj rotirajućeg dijela motora (zamašnjak motora).

Dinamometri okretnog momenta i sile na kotačima, inkrementalni davači impulsa te klizni prstenovi bili su zaštićeni oklopima od mogućih mehaničkih oštećenja kao i atmosferskih utjecaja. Za električno napajanje svih davača i prikupljanje mjernih podataka iz mjernog signala služila su tri mjerna pojačala, Spider 8, Hottinger Baldwin. Za mjerenja je upotrijebljen program Catman, Hottinger Baldwin. Napajanje svih pojačala vršeno je

preko benzinskog agregata za el. energiju koji je bio pričvršćen na laboratorijsko vozilo koje je pratilo traktor u toku eksperimenta. Sva mjerenja izvršena su na ravnom i nagnutom terenu, kao i različitim tipovima podloga (asfalt, izorana tla, livada itd.). Kod njih je praćen okretni moment na svakom pogonskom kotaču traktora, dinamičko prenošenje sile na svaki kotač (u radu na nagibu), klizanje svakog kotača, ukupno prijedeni put traktora, uzdužni i poprečni nagib traktora prilikom gibanja (u slučaju rada na nagibu), okretni moment na priključnom vratilu (za pogon priključaka), okretni moment na izlazu iz motora te broj okretaja motora i priključnog vratila. Sve spomenute mehaničke veličine mjerene su istovremeno. Podaci dobiveni mjerenjima obrađeni su u programu Excel.

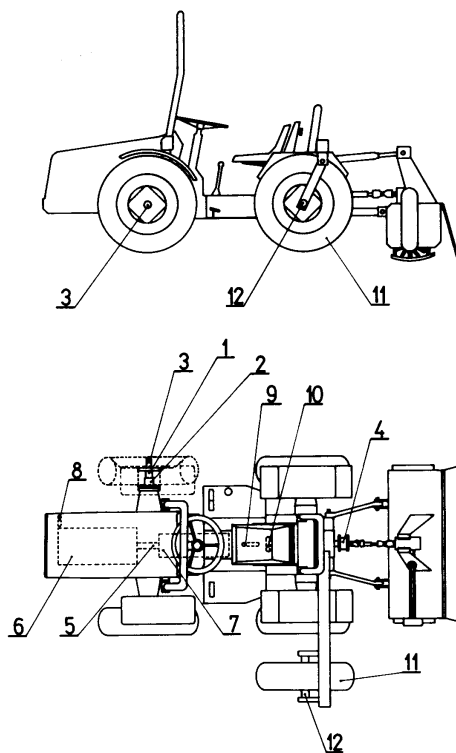

Slika 1. Mjerna mjesta na traktoru AGT 835 sa hidromehaničkom transmisijom: 1 – dinamometar okretnog momenta kotača, 2 – dinamometar za silu na kotaču (u slučaju rada na nagibu), 3 - inkrementalni pretvarač za registriranje broja impulsa (za utvrđivanje postotka klizanja kotača) i klizni prstenovi za električno napajanje dinamometara i prikupljanje mjernih signala, 4 – dinamometar okretnog momenta i broja okretaja priključnog vratila, 5 – dinamometar okretnog momenta motora, 6 – motor, 7 – transmisija (hidromehanička), 8 – induktivni senzor za broj okretaja motora, 9 – induktivni senzor za mjerenje uzdužnog nagiba, 10 – induktivni senzor za mjerenje poprečnog nagiba, 11 – kotač za mjerenje prijedenog puta, 12 - inkrementalni pretvarač za registriranje broja impulsa (za utvrđivanje prijedenog puta)

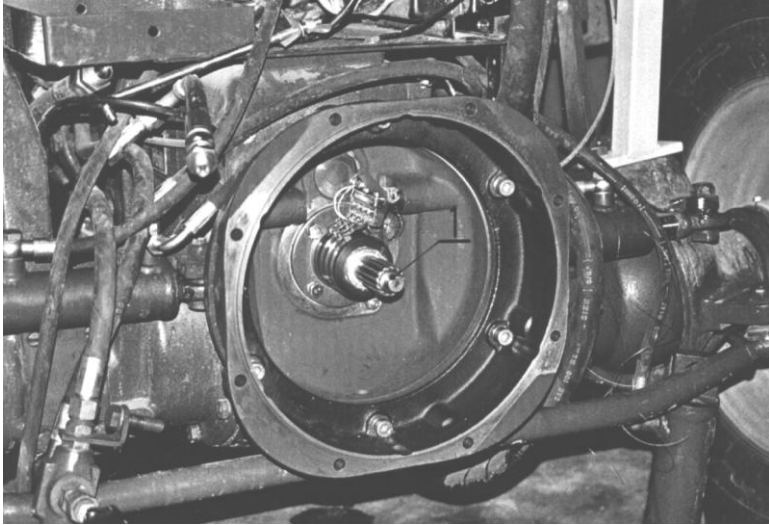

Slika 2. Dinamometar za mjerenje okretnog momenta (1) bio je namješten na izlazu iz motora odnosno između motora i transmisije (ulaz na hidromehaničku transmisiju)

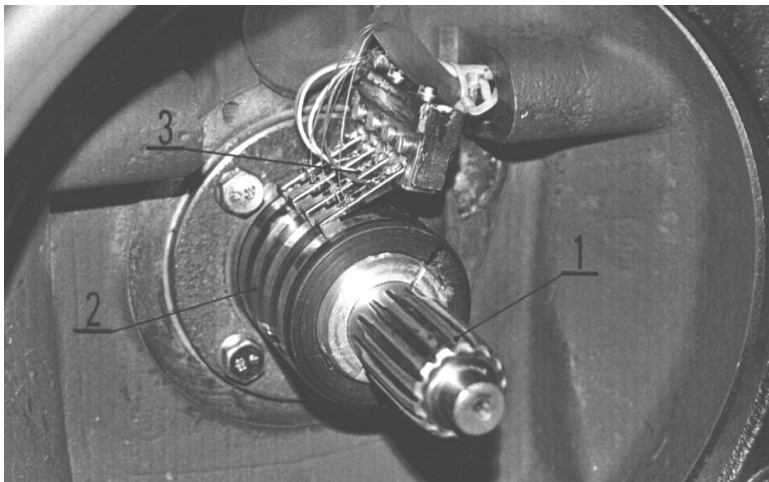

Slika 3. Za napajanje dinamometra za mjerenje okretnog momenta na motoru (1) električnom energijom i primanje izmjerene signala bili su namijenjeni klizni kontakti – prstenovi (2) te četkice (3), cijeli sistem bio je zatvoren na mjestu gdje se nalazi traktorska spojka.

REZULTATI RADA I DISKUSIJA

Mjerenja su izvršena u razdoblju travanj do prosinac 2001 na Kmetijskom institutu Slovenije, u laboratoriju za testiranje poljoprivrednih strojeva i procesne tehnike kao i na pokusnim poljima (laboratorij i pokusna polja su na lokaciji Jable 12 km od Ljubljane). Mjerenja su izvršena u neopterećenom i opterećenom stanju (kočenje traktora drugim vozilom) na asfaltnoj podlozi te sa različitim priključcima za osnovnu i dopunsku obradu tla te rotacijskom kosilicom. Mjerenjima su dobiveni podaci za svaki kotač traktora: o okretnom momentu, dinamičkom prijenosu sile na kotač i postotku klizanja. Isto tako dobiveni su i podaci o okretnom momentu motora te broju okretaja motora traktora. Za priključke koji su upotrijebljeni u mjerenjima a pogon dobivaju preko priključnog vratila traktora, freza i rotacijska kosilica, dobiveni su i podaci o okretnom momentu na priključnom vratilu i broj okretaja priključnog vratila. U slučaju mjerenja na nagibu dobiveni su podaci o uzdužnom i poprečnom nagibu traktora (kutne vrijednosti). Izmjerene vrijednosti istovremeno su i pohranjene na računalo. Frekvencija uzimanja uzoraka iz mjernog signala iznosila je 10 Hz. Pojedinačna mjerenja trajala su 120 – 180 sekundi. Mjerenje su isto tako vršena pri gibanju traktora po ravnom terenu bez opterećenja (određivanje gubitaka za samo kretanje traktora) te kod gibanja uz strminu i niz strminu bez i pod različitim opterećenjem (npr. rotacijska kosilica). Pomoću mehaničkih veličina dobivenih iz podataka mjerenja utvrđena je potrošnja energije traktora, stupanj oštećenja radne podloge, stupanj korisnog djelovanja transmisije, opterećenost transmisije itd. Dva primjera izmjerenih signala predstavljena su na slijedećim slikama. U toku mjerenja dobiveno je nekoliko stotina izmjerenih signala koji predstavljaju odličnu osnovu za analize ponašanja traktora u radu.



Slika 4. Mjerenje na traktoru agregatiranom sa rovilicom (frezom)

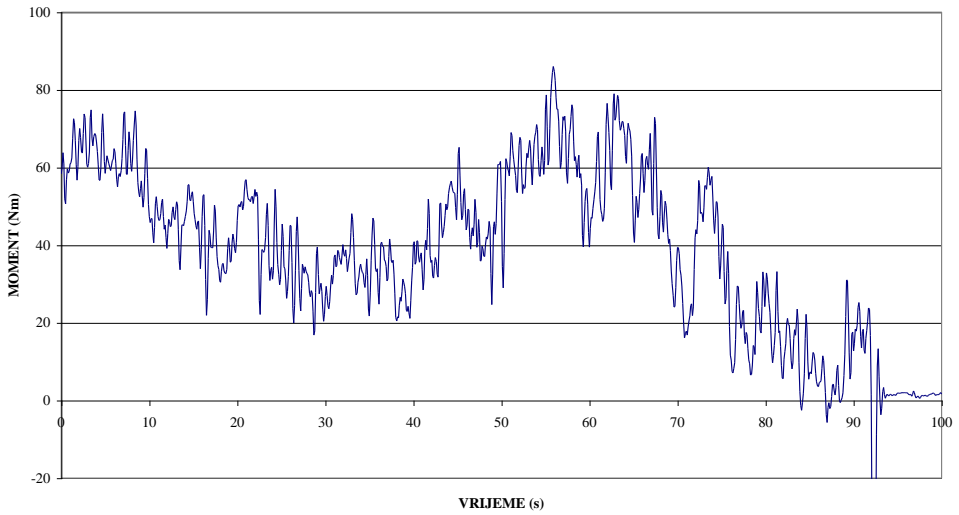

Slika 5. Oscilogram okretnog momenta motora traktora AGT 835 (hidromehanička transmisija), dinamometar za mjerenje okretnog momenta bio je namješten na izlazu iz motora i ulazu u transmisiju

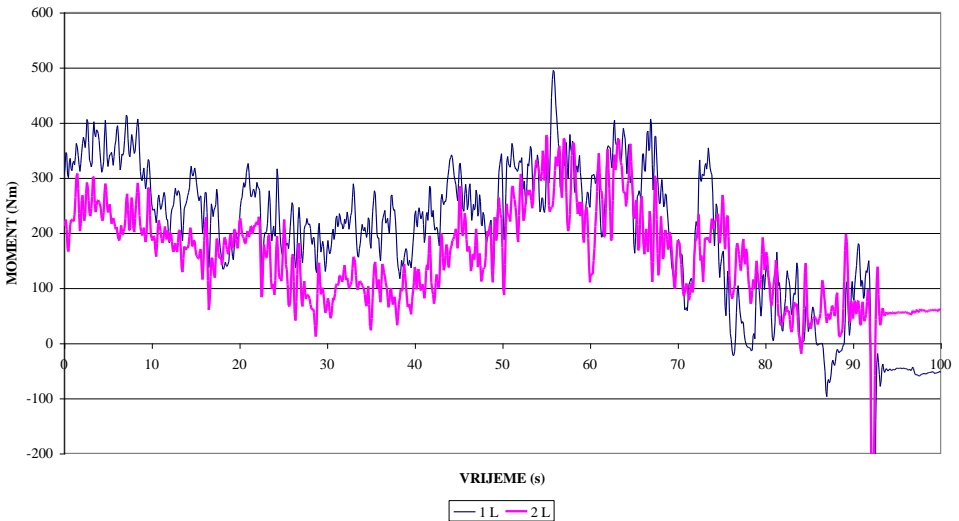

Slika 6. Oscilogram okretnog momenta prednjeg i zadnjeg kotača traktora AGT 835 (hidromehanička transmisija) na lijevoj strani (gledano u smjeru gibanja traktora), okretni moment snimljen je kod opterećenja traktora u radu sa priključkom

Mjerna oprema izvršila je zadatke koji su postavljeni pred nju. Nakon otklanjanja nekih početnih nedostataka sa kliznim prijenosnicima za napajanje i prijenos mjernog signala funkcionirala je besprijekorno u spomenutom testnom razdoblju. Čak niti u periodu niskih temperatura nije dolazilo do otkazivanja mjerne opreme.

ZAKLJUČAK

Razvijena je posebna mjerna oprema koja omogućuje mjerenje najvažnijih mehaničkih veličina koje se pojavljuju na traksijsko odnosno transmisijskom dijelu traktora, prilikom rada traktorom AGT 835 u realnim uvjetima. Mjerna oprema omogućava precizno utvrđivanje traksijske sile na svakom kotaču traktora odnosno cjelokupne traksijske sile traktora. Rezultati dobiveni mjerenjima omogućuju utvrđivanje angažirane traktorske snage za pogon različitih traktorskih priključaka kao i utvrđivanje stupnja korisnog djelovanja traktorske transmisije. Oprema isto tako omogućuje istraživanja koja su povezana sa proučavanjem podloge po kojoj se traktor kreće u radu (odgovor na stupanj oštećenja podloge koje prouzrokuje traktor opremljen sa mehaničkom odnosno hidromehaničkom transmisijom). Podaci dobiveni mjerenjima omogućiti će usporedbu utroška energije traktora AGT 835 opremljenog sa mehaničkom transmisijom i hidromehaničkom transmisijom. Proizvođač traktora dobiti će isto tako neophodne podatke o opterećenosti transmisije traktora što predstavlja osnovu za moguće odnosno potrebne modifikacije traktora u budućnosti.

LITERATURA

1. CAVALLO, E.: (2001) Sollevatori telescopici: un concentrato di idraulica, Macchine e motori agricoli, Calderini Sri, br.4, Bologna, str. 58 – 60
2. CIGR Handbook of Agricultural Engineering, skupina autorja, 3. dio, ASAE, poglavlje Tractors: Two Axle Tractors, avtor Renius, K.T., St. Joseph, Michigan, 1999 ZDA, str. 139 – 15
3. GOERING, C.E.: (1992) Engine & Tractor Power 3. izdanje, ASAE Textbook 3, St. Joseph, Michigan ZDA, str. 446 - 452
4. GREVIS-JAMES, I.W., BLOOME, P.D.: (1982) A Tractor Power Monitor, Transactions of ASAE, ZDA, str.595 – 597
5. JEŽIČ, V.: (2000) Hidrostatična transmisija, Tehnika in Narava, br. 3, ČZD Kmečki glas, Ljubljana, str. 18 - 19
6. JEŽIČ, V.: (2000) Hidrostatična transmisija traktorjev, gradivo za seminar: Hidravlika na traktorjih in kmetijskih strojih, Kmetijski inštitut Slovenije, Ljubljana
7. JEŽIČ, V.: (2000) Hidrostatične transmisije sodobnih traktorjev, zbornik simpozija Novi izzivi v Poljedelstvu, Slovensko agronomsko društvo, Ljubljana, str. 65 – 69.
8. JEŽIČ, V.: (2001) Kontinuirano varijabilna transmisija suvremenih traktora, Zbornik simpozija Aktualni zadaci mehanizacije poljoprivrede, Agronomski fakultet Sveučilišta u Zagrebu, Zagreb, str. 79 – 86.

9. JEJČIČ, V., POJE, T., MARENČE, J., KOŠIR, B.: (2001) Razvoj mjerne opreme za šumarski traktor Woody 110, Zbornik simpozija Aktualni zadaci mehanizacije poljoprivrede, Agronomski fakultet Sveučilišta u Zagrebu, Zagreb, str. 111 – 117.
10. JEJČIČ, V.: (2001) Kontinuirano varijabilne traktorske transmisije, Zbornik simpozija Trendi v razvoju kmetijske tehnike 2001, Društvo kmetijske tehnike Slovenije, Ljubljana, str. 147 – 154
11. KOŠIR, B.: (2000) Lastnosti prenosa sila na podlagu pri traktorju Woody 110, Gozdarski vestnik št. 3, Ljubljana, str. 139 - 145
12. MILIDRAG, S.: (1998) Kompozicija hidrodinamičkog menjača u cilju povećanja ekonomičnosti rada poljoprivrednih traktora, Traktori i pogonske mašine JUMTO, Novi Sad, br. 4, str. 35 - 40
13. RENIUS, K.T.: (1985) Traktoren, 2. izdanje, BLV, München, str. 86 - 87
14. TOMPKINS, F.D., WILHELM, L.R.: (1982) Microcomputer-Based, Tractor Data Acquisition System, Transactions of ASAE, ZDA, str. 1540 – 1543

DEVELOPMENT OF MEASURING EQUIPMENT FOR TRACTOR AGT 835

SUMMARY

For investigations of tractor AGT 835 with mechanical and hydromechanical transmissions in work in real working conditions, special measuring equipment was developed. Measuring equipment allows simultaneous measurement of: torque on wheel axis, dynamical force on wheel, number of revolutions of wheel, travel distance, torque on engine, number of engine revolutions, torque on PTO shaft and number of revolutions of PTO shaft. At the same time at the tractor is possible measuring angle of tractor in longitudinal and lateral direction on variagated relief. Energy consumption of tractors was determined with measuring equipment on tractors loaded in work with different tractor implements.

Key words: *tractors, measuring equipment, electrical measurement of mechanical quantities on tractors*

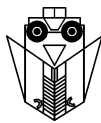

VUČNE KARAKTERISTIKE TRAKTORA AGT 835H SA HIDROMEHAČNOM TRANSMISIJOM

ANTON ŠTERN

Srednja šola kmetijske mehanizacije
Maribor, Slovenija

SAŽETAK

U posljednjih godinama većina je renomiranih svjetskih tvornica traktora razvila i tržištu ponudila traktore sa hidrostatskom transmisijom. Uz tvrtku Fendt to su John Deere, Case, Deutz-Fahr i drugi koji proizvode traktore manje snage a među njima je i Agromehnika iz Kranja u R. Slovenji. Ključni dio suvremenog traktora su na novo razvijene transmisije. Uglavnom radi se o hidromehaničkoj transmisiji ili transmisiji sa diobom snage, koja ima i najveći stupanj korisnog djelovanja. Traktor AGT 835H manje je snage, standardne već od prije poznate konstrukcije sa pogonom na sva četiri kotača. Transmisija je uzastopna hidrostatsko - mehaničke izvedbe. Tri mehanička stupnja omogućavaju prilagođavanje različitim režimima te opterećenjima u radu. Agromehnika iz Kranja je hidrostatsku varijantu traktora razvila za komunalne namjene. Traktor predstavljen u ovom prilogu je prototipna izvedba poljoprivrednog traktora. Na mjerjenjima vučnih i eksploatacijskih karakteristika traktora dobili smo dosta dobre rezultate.

Ključne riječi: traktor, hidrostatska transmisija, vučne karakteristike.

UVOD

Traktor kao osnovni stroj i platforma za priključivanje radnih strojeva imao je i još uvijek ima ključnu ulogu u mehanizaciji poljoprivrede. Razvojem tehnike i agrotehnike te uvođenjem suvremene mehanizacije u poljoprivredu bitno je uvećana produktivnost te udobnost rada a posebno količina i kvalitet uroda. Traktor je prošao više faza u svom razvoju, čemu su brzo slijedili i ostali poljoprivredni strojevi. Ključni poticaj brzom uvođenju hidraulike u toku osamdesetih i devedesetih godina je izniman razvoj elektronike a istodobno i potreba po što lakšem i jednostavnijem upravljanju strojeva. Već u 50-im godinama bilo je pokušaja razvoja hidrostatskih ili djelomično hidrostatskih transmisija. Na Institutu za poljoprivrednu mehanizaciju NIAE (National institute of Agricultural

Engineering) u Engleskoj su 1954 godine izradili prvo hidrostatsko transmisiju CVT (kontinuirano variabilna transmisija) sa variabilnom pumpom i hidromotorima radialno poredanima na pogonskim kotačima. Vjerovatno zbog tehničko tehnoloških nedostataka, visoke cijene i problema sa odgovarajućim hidrauličkim komponentama, razvoj se nije nastavio. Već u 60-ih godinama je CASE ponudio tržištu prvu hidromehaničku transmisiju, koja zbog visoke cijene i nedostatka nije prihvaćena u proizvodnji.

Sredinom devedesetih godina počela je firma Fendt sa proizvodnjom hidromehaničke kontinuirano variabilne transmisije (CTV) sa diobom snage. Snaga se u tehničkom smislu zapravo dijeli, uspredno prenosi te na kraju odružuje. Najprije biva transmisija ugrađena u modele traktora serije 900, kasnije 700 a u posljednje vrijeme i u najmanju seriju 400. U zadnje vrijeme na području kontinuirano variabilnih transmisija tvrtku Fendt brzo slijede i John Deere, koji u 4 tipa traktora serije 6010 snage od 77 do 103 kW ugrađuje variabilnu transmisiju nazvanu AutoPower te Deutz-Fahr i Case.

U Sloveniji tvrka VILPO od godine 94 razvija i proizvodi zglobni traktor Woody snage 51 do 81 kW, koji ima ugrađenu potpuno hidrostatsku CVT. Snaga motora se preko crpke i cijevi prenosi na hidromotor priključen na mjenjač sa dva mehanička stupnja i diobenik snage putem kojeg se snaga dijeli na prednji i stražnji most.

Kod nekih manjih traktora projektiranih uglavnom za potrebe komune a u zadnje vrijeme i za lakše radove u povrćarstvu i ratarstvu razvijena je klasična hidrostatska (CVT) transmisija, koja u svom nizu ima ugrađeni mehanički mijenjač s nekoliko (uobičajeno 2 – 3) stupnja. Ovakva transmisija je dosta jednostavna, sastavljena većinom od klipne aksijalne pumpe s nagibnom pločom, koja omogućava regulaciju protoka te smjera fluida (regulacija brzine i smjera vožnje) te klipng aksijalnog hidromotora. Pri čemu je najčešće hidromotor bez mogućnosti regulacije.

Ovakav tip transmisije se ugrađuje u traktore manje snage cca. do 35 kW, npr. Antonio Cararo, Agromehanika (AGT), Murray, Craftsman i slično.

Traktor AGT 835H firme Agromehanika je krute standardne izvedbe u sredini oko uzdužne ose okretljiv, sa stalnim pogonom na sva četiri jednaka kotača. Prednji pokretni kotači omogućavaju vođenje traktora u željenom smjeru.

U traktor je ugrađen 3 - cilindarski vodom hlađeni motor marke Lombardini. Radni volumen motora iznosi 1.551 cm^3 . Motor razvija snagu 26,4 kW i moment 95,4 Nm kod 2100 okretaja. Maksimalni broj okretaja iznosi 3100 min^{-1} . Maksimalna brzina (prema tvorničkim podacima) traktora je 24 km/h.

Mjenjač je mehaničko - hidrostatski sa ugrađenom crpkom i hidromotorom talijanske firme Bondioli & Pavesi. Crpka je aksialno batne izvedbe regulirana pločom promjenljivog nagiba. Kosina ploče i time smjer i protok ulja reguliraju se nožnim ventilom – papučom. Ploča regulacijom protoka ulja omogućava promjenu brzine i smjera vožnje. Hidromotor je konstantnog protoka. Mehanički mjenjač sa tri mehanička stupnja ugrađen je iza hidromotora. Promjenom stupnja omogućeno je biranje režima rada (I stupanj – težak rad, II stupanj lakši i brži rad, III stupanj transport). Stražnje priključno vratilo je direktno mehanički pogonjeno sa standardnim brojem okretaja 540 min^{-1} . Prednje priključno vratilo s 1000 okretaja uključuje se hidraulički. Stražnja i prednja hidraulika je kategorije (I) upravljana mehaničkim ventilom (podizanje-neutralno-spuštanje).

CILJEVI I METODE RADA

Cilj ovog rada je utvrditi vučne karakteristike traktora AGT 835H te odrediti primjerenost za agregatiranje strojeva, koji traže veće vučne sile s osvrtom na gubitke energije u transmisiji.

Mjerenja su izvođena na poligonu Kmetijskega instituta Slovenije u Jablana kraj Ljubljane. Mjerali smo najprije na poligonu odnosno na asfaltnoj cesti gdje su praćene vučne karakteristike traktora, broj okretaja i potrošnja goriva, čime možemo izraziti prosječne vrijednosti vučnih sila kod određenog klizanja i u određenom režimu rada. Možemo također izračunati potrošnju goriva na sat i proizvedeni kWh energije, vučnu snagu te gubitke energije zbog klizanja i trenja kotača u tlu.

Mjerenja su izvođena također u polju sa nekim priključcima (plug, freza, sjetvospremač i kosilica). Mjereni su slični parametri kao na poligonu. Mjerenjima u polju htjeli smo utvrditi primjerenost traktora u agregatu za pojedine poljoprivredne radove. Nas prije svega zanimaju rezultati mjerenja eksploatacijskih karakteristika traktora u agregatu sa plugom, koji angažira i najveću vučnu silu. U tu namjenu traktor je agregatiran sa dvolemešnim plugom od 8 cola (49 cm).



Slika br.1. Mjerenje u oranju

U polju se mjerilo na strništu odmah poslije žetve. Tlo je bilo dosta malo zbijeno, srednje teško, uglavnom ilovača sa dosta humusa. Prosječna vlaga u tlu je iznosila 18,6%. Brzina rada se kretala između 5 i 6 km/h, prosječna širina brazdi bila je 41 cm a dubina oko

16 cm. Specifični otpor tla izmjeren pomoću horizontalnog penetrometra iznosio je između 4,5 i 4,8 N/cm².

Za ova ispitivanja traktor je pripremljen namještanjem specijalno razvijene mjerne opreme, senzora i mjernih doza. Na svaki kotač namještena je mjerna doza, koja omogućava mjerenje sile i zakretnog momenta. Na svaki kotač dodat je davač impulsa koji služi za točno mjerenje okretaja. Okretaji se mjere i na petom – »referentnom« kotaču. Također se mjere i okretaji te moment motora (što je nešto novo) na ulazu u mjenjač. Dodatno se mjeri vučna sila na mjernoj dozi, pričvršćenoj na žičnu pletenicu (sajlu) koja služi za kočenje traktora Land Roverom. U polju kao »kočnica« djeluje priključak.

Mjerni signali vođeni su koaksialnim kablovima do pojačala Spyder 8 smještenog u vozilu Land Rover sa ostalom mjernom opremom. Više pojačala vezano je na kompjutor za izravno prihvaćanje i kasniju obradu podataka. U prosjeku se mjerilo do 17, ponekad čak i 19 parametara. Numerički podaci su obrađivani na osobnom računalu sa programskim oruđem MS Excel.

Prije početka mjerenja je napravljeno cjelovito baždarenje mjerne opreme, kontrola pritiska u gumama, te kontrola samog traktora. Na početku svakog mjerenja je potrebno tariranje mjernih parametara.

Sva mjerenja u svim varijacijama su ponavljana najmanje tri puta, da bi dobili što reprezentativnije podatke.

REZULTATI ISPITIVANJA

Traktor AGT 835H ima tri područja radnih brzina, koje se biraju mehaničkim mjenjačem i kreću od

- 0 – 6,2 km/h, pri čemu su vučne sile od 4 pa do 11 kN,
- 0 – 12,5 km/h s vučnim silama od 2 pa do 5,6 kN i
- 0 – 22,5 km/h a vučne sile se kreću negdje od 1 – 2,9 kN.

Unutar mehaničkih područja je pomoću nožnog ventila potpuno bezstupanjsko biranje omjera između željene sile, brzine i smjera kretanja (grafikon 1).

Podaci su izmjereni na asfaltnoj cesti na punom gasu to jest na oko 3000 - 3100 okretaja motora.

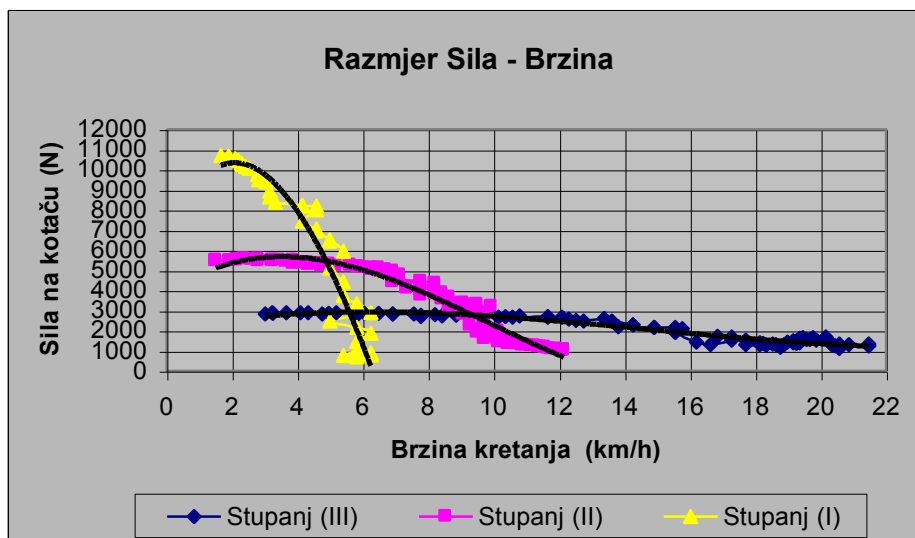

Grafikon 1. Odnos između sile i brzine kretanja, ovisno o stupnju (I, II, III)

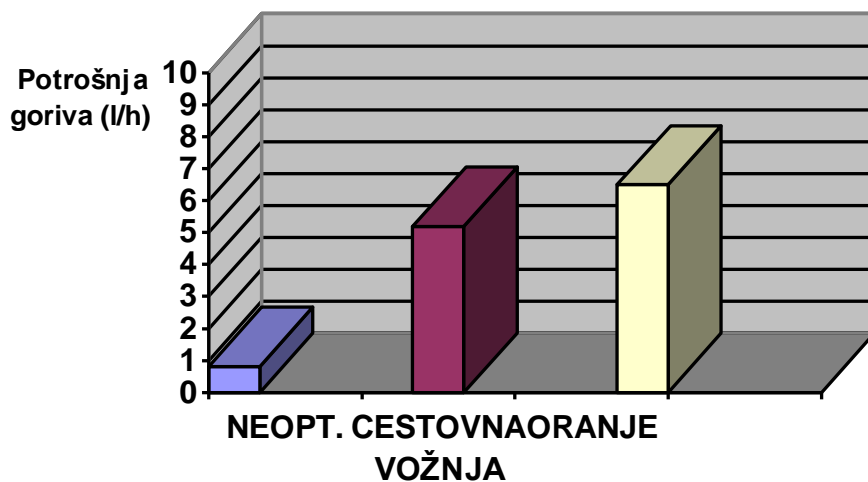

Grafikon 2. Potrošnja goriva u radu se kretala između 3 – 7 kg na sat, zavisno od težine i intenzivnosti vuče tereta. Kod neopterećenog motora – minimalni broj okretaja potrošnja goriva je bila 0,7 l/h, kod cestovne vožnje – puni broj okretaja se kretala oko 5,2 l/h a kod oranja 6,5 l/h

Već mjerenjima na cesti je utvrđeno, da traktor realizira dosta velike vučne sile. Mjerenja vučnih karakteristika traktora u agregatu sa plugom dala su slijedeće rezultate.

Angažirana vučna sila kreće se između 5 i 7,5 kN uz klizanje između 12 i 18 %. Snaga na kotačima uz brzinu kretanja 4,7 – 5,8 km/h iznosi od 8 – 12 kW. Angažirana snaga za vuču pluga kreće se od 3 – 6,4 kW.

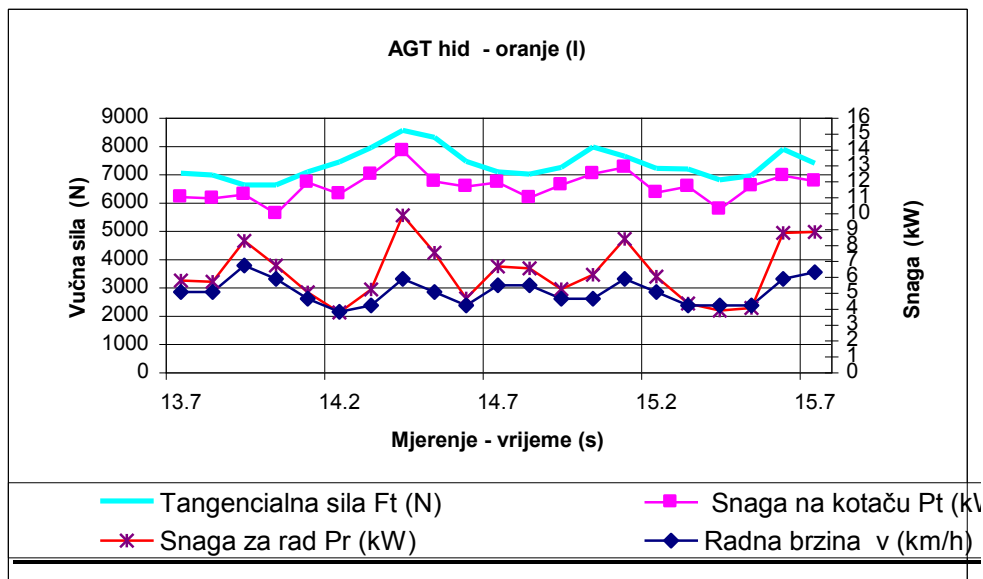

Graf br. 3. Iz grafa je vidljiva struktura angažiranih sila i bilanca snage. Traktor je dosta dobro savladavao oranje u strmištu, osim na mjestima gdje su bila tla puno više zbijena (kolnice od stalnih tragova kotača).

ZAKLJUČAK

Traktor ima dobre vučne karakteristike s vučnom silom čak 11 kN. Ima odlične manevarske mogućnosti (naprijed nazad) i to bez promjene mehaničkog stupnja prijenosa.

Oranjem u uslovima (dosta pogodnim) traktor je savladavao vuču pluga bez problema, čak s nekim ostatkom snage ali samo unutar (I) mehaničkog područja. U (II) području hidrostatska transmisija traktora je suviše opterećena, dolazi do većeg termičkog opterećenja i zagrijavanja ulja u hidrauličkom sustavu kojeg ventilator ne savladava.

Može se zaključiti da na lakšim tlima i kod manjih brzina traktor može raditi i kroz duže vrijeme. Kod većih opterećenja su i gubici snage u hidrostatskoj transmisiji suviše veliki.

Traktor je prototipne izvedbe, namijenjen poljoprivrednim radovima kod kojih se ne traži konstantno velika vučna sila i gdje je nužno dosta manevriranja. Idealan je za priključke, koji rade na manjim brzinama i traže veći dio snage preko priključnog vratila.

LITERATURA

1. RENIUS, K.T.: (1985) Traktoren, drugo izdanje, BLV, Muenchen.
2. TODOROVIĆ, J.: (1986) Ispitivanje motornih vozila, III dopunjeno izdanje, Mašinski fakultet Beograd.
3. HONZEK, R., (1996) firma AGCO: Fachbereichsleiter – stufenlose Getriebe, Marktoberdorf.
4. KOŠIR, B.: (2000) Lasnosti prenosa sila na podlago pri traktorju Woody 110, Gozdarski vestnik št. 3, Ljubljana, str. 139 – 145,
5. JEJČIČ, V.: (2000) Hidrostatične transmisije traktorjev, Kmetijski inštitut Slovenije, Ljubljana.
6. POJE, T.: (1996) Potrošnja energije radom traktora s priključcima za različite načine obrade tla, magistarski rad, Agronomski fakultet Zagreb.
7. Zbornici radova sa međunarodnih savjetovanja, Opatija 1995- 2001,
8. PROFI, stručna revija, stručni članci, godišta 1996- 2001,
9. Tehnika in narava, stručna revija ČZP Kmečki glas Ljubljana, godišta 1997- 2001,
10. Stučno i kataloško građivo tvornica traktora i poljoprivrednih strojeva

DRAWBAR PERFORMANCE OF TRACTOR AGT 835H

SUMMARY

The paper presents results of tractor AGT 835H drawbar performance testing. The testing was carried out at tarmacadam surface and in the field conditions. Since this tractor model is equipped with hydrostatic-mechanical transmission it was necessary to determine its working capabilities. Results of these testing showed that tractor AGT 835H has very good maneuverability due to its specific transmission, while according to drawbar performance tests, its utilisation is recommended to jobs where constant high drawbar pull is less important.

Key words: *Tractor, hydrostatic-mechanical transmission, drawbar performance*



AN ATTEMPT TO DEVELOP AN ELECTRIC AGRICULTURAL VEHICLE BY THE MICROWAVE POWER TRANSMISSION

AKIRA OIDA

Graduate School of Agriculture
Kyoto University
Kyoto, Japan

SUMMARY

This is the first trial that realizes the appearance of an electric agricultural vehicle, which has neither combustion engine nor battery but only electric motors. Necessary electric power is transmitted by means of microwave in space. The microwave power transmission is a unique, epoch-making and the best method for human being to obtain absolute clean energy, when it will be used to transmit electricity from the future power station in the space to the earth. Applying the microwave power transmission technology to drive agricultural vehicles, an ideal vehicle can be designed and developed, that has no emission, no heavy battery, is small and light, with low energy consumption and flexible form. A small model of agricultural vehicle was designed and constructed with the rectifying antenna. The running test of the vehicle by the microwave energy was successfully done in Kyoto University in June 2001.

Key words: *electric agricultural vehicle, microwave power transmission, environmental conservation*

INTRODUCTION

Even in the research fields of agricultural machinery we have to pursue the realization of electric off-road vehicles, which exhaust no harmful gas, from the environmental conservation point of view. It is said that agriculture has a contribution of 9 % on the global warming according to the IPCC report. It was found that Japanese agriculture shares about 3 % of total exhausted carbon dioxide in Japan. In order to reduce the emission of carbon dioxide from agricultural vehicles and to contribute to protecting the global climate from our research field, it is necessary to develop electric off-road vehicles. We have already

investigated and showed the possibility of future electric tractor from some viewpoints including the required power, battery performance, vehicle structure, improved low energy cropping system, and so on [Oida et al., 1996].

Agricultural vehicles have different characteristics from those of passenger cars. The task of agricultural vehicles is to “work” such as to do plowing, rotary tilling, transplanting, harvesting, pulling a cart and so on, besides running. In other words, the agricultural vehicle continuously needs a certain percent of output power of engine or battery. Sometimes it consumes almost full output power of engine for instance at rotary tilling. Therefore, if the power source of electric agricultural vehicle is a battery with the output density of for example 120 W/kg and energy density of 80 Wh/kg, the vehicle has an electric motor of 33 kW and batteries of 500 kg, and the vehicle tills normal field by a normal rotary tiller, the working time would be restricted by only 2 hours. A battery-driven vehicle is not the solution in the case of agricultural vehicle. A fuel cell could be applied, but there would be still a problem of fuel supply. We would like to develop a future ideal agricultural vehicle. It should be light in order to save energy, and not exhaust any emission for environmental conservation.

We have reached one of solutions that the electric agricultural vehicle should have neither battery nor fuel cell, but only motors, which drive the running device and implements to work, and the motors would be driven by electricity transmitted by microwave in space.

MICROWAVE POWER TRANSMISSION

The first person who conceived and tested on radio power transmission was Nikola Tesla, who tried to distribute ten thousand PS under a tension of one hundred million volts in 1899 [Matsumoto, 1995]. He actually built a gigantic coil and fed 300 kW power to the coil resonated at 150 kHz. After some decades blank of concerns for radio power transmission, the magnetron and the klystron, which are devices to generate high-power microwaves, were invented in 1920's and 1930's. Though the high-power microwave generators and antennas appeared as the radar technology was developed during World War II, no power device was available to convert a microwave power beam back to DC power until the 1960's.

W.C. Brown succeeded in demonstrating a microwave-powered helicopter in 1964, using the microwave of 2.45 GHz and a rectenna, which was a power conversion device from microwave to DC and was composed of 28 half-dipoles terminated in a bridge rectifier using point-contacted semiconductor diodes. Jet Propulsion Lab Goldstone Facility successfully transmitted a microwave power from a large parabolic antenna dish to a 1.6 km far rectenna, which showed a conversion efficiency of 84 % (i.e. the ratio of DC output to microwave power absorbed by the rectenna), in 1975. The DC output was 30 kW.

The concept of Solar Power Satellite (SPS) appeared and was studied in 3-year program called the DOE(Department of Energy)/NASA Satellite Power System Concept Development and Evaluation Program, started in 1977, that was to design to beam down the electrical power of 5 to 10 GW from one SPS toward the rectenna site on the earth. The microwave impact onto the space plasma environment was theoretically and experimentally

investigated. The influence of radiation of an intense 2.45 GHz microwave into the ionospheric plasma was researched by in-situ MINIX (Microwave Ionosphere Nonlinear Interaction experiment) rocket in Japan in 1983 [Nagatomo et al., 1986].

Microwave power transmission has been applied to some actual cases but in test stage. A 1/8-scale prototype SHARP (Stationary High Altitude Relay Platform) flew on beamed microwave power for 20 minutes at an altitude of about 150 m in Canada in 1987 [Schlesak, 1988]. The MILAX (Microwave Lifted Airplane Experiment) airplane flew successfully for 40 seconds at an altitude of about 15 m in Japan in 1992 (Matsumoto et al., 1993). There were/are other plans such as ground-to-ground and ground-to-space power transmission without wires, and so on.

TRANSMITTER AND RECEIVER OF MICROWAVE

Microwave Transmitter

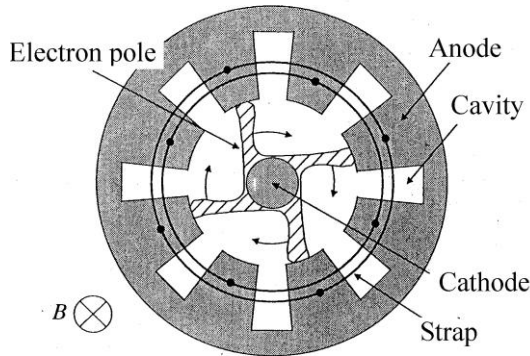

Figure 1 Internal structure of magnetron

Microwave is generated by a magnetron. The magnetron can be considered to be an electron tube, which can oscillate high power microwave, forming a feedback loop by connecting input-end and output-end of a traveling wave tube. Figure 1 shows an internal structure of the magnetron. The principle of magnetron's oscillation is as follows: When a magnetic field, which is parallel to a cathode axis, is acted for an electron which comes out from the cathode, the electron rotates affected by the Lorentz's force and reaches to an anode. Because of an oscillation cavity of the anode, the cavity equivalently becomes a LC resonator and neighbor anode plates form a resonance circuit individually, so that an electric vibration, which exists in the resonance circuit, generates a high-frequency electric field. The electron in a space from the high-potential anode to low-potential anode is decelerated in the direction of circumference, the Lorentz's force decreases, and then its curvature becomes smaller, so that the electron approaches to the anode. On the other hand, the electron in a space from the low-potential anode to high-potential anode is accelerated in the circumferential direction and approaches to the cathode by the Lorentz's force. By this way an electron pole is generated as shown in Fig. 1. Every time the electron pole

passes the anode space at the rotation, the induced current is poured into the high-potential anode from the low-potential anode that assures the continuous high-frequency oscillation. In the case of the oscillation, there is a fear of discontinuous variation of oscillation frequency owing to a shift of oscillation mode by a slight change of load. Therefore, one oscillation mode is tried to be hold by connecting every other anode in order to set the same potential, utilizing an annular electrode (strap). Figure 2 shows a horn antenna, which was used in this experiment. The oscillation frequency of microwave was 2.45 GHz (wavelength of 122 mm) and the maximum output power was 600 W.

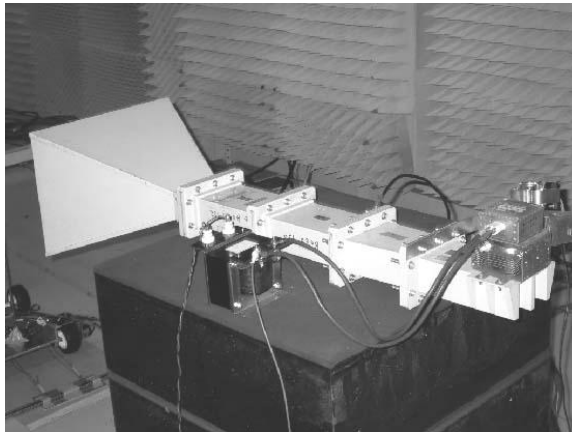

Figure 2 Horn antenna

Rectifying Antenna (Rectenna)

As a receiving device of microwave energy a rectifying antenna called “rectenna” was used (Fig. 3). The rectenna receives microwave energy and convert it into DC power. The rectenna is generally composed of an antenna, input filter, rectifier and output filter. The antenna is a circular microstrip one of a half wavelength diameter. The rectifying circuit is constructed by microstrip lines as shown in Fig. 4. The substrate of the circuit is made of glass-cross-teflon with the specific permittivity of 2.21 and thickness of 1.6 mm. The microwave energy comes into the point “A” in the figure and the DC power is got between “B” and the ground. “C” means a chip condenser, which stops a backward flow of DC power to the antenna part. ”D” is a silicon schottky barrier diode (1SS281). In order to get a large power, a rectifying circuit with three diodes in series and parallel in a 4-way power divider was used in the experiment. The output filter is composed of 1/4 wavelength transmission lines (“E1” and “E2”) and 1/8 wavelength open stubs (“F1” and “F2”). Microwave energy to DC energy conversion efficiency (RF-DC conversion efficiency) of the rectifying circuit varies depending on the input power and the load. In the case of this experiment the efficiency was about 47 % at the maximum input power of 17 to 20 W.

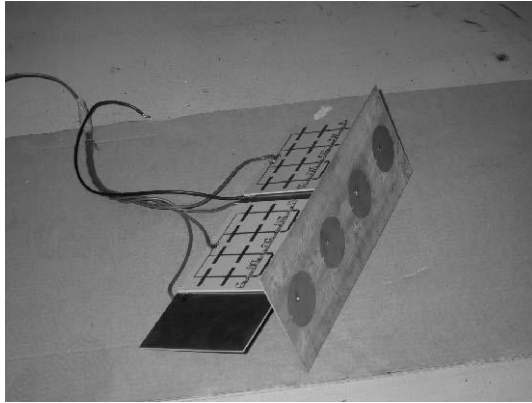

Figure 3 Rectenna used in the test

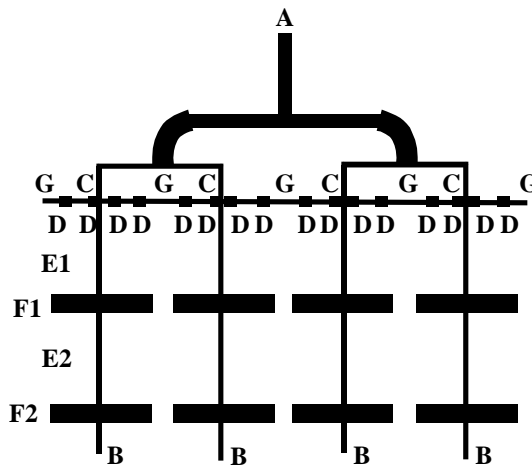

Figure 4 Rectifying circuit

TEST MODEL VEHICLE

A small model vehicle (length 457 mm, width 370 mm, height 120 mm, mass 3.04 kg) was constructed (Fig. 5). It has two axles and 4 tires (diameter 88 mm, width 43 mm). As a driving device, only a DC motor (nominal voltage 12 V, output power 7.2 W, reduction gear ratio 1/96) was placed on the flat floor of the vehicle and it drove the front axle. The vehicle had a pole, where the rectenna (4 circular antennas and 4-way power divider for each antenna) was attached. We measured the input voltage and current of the motor and revolution speed of motor axle.

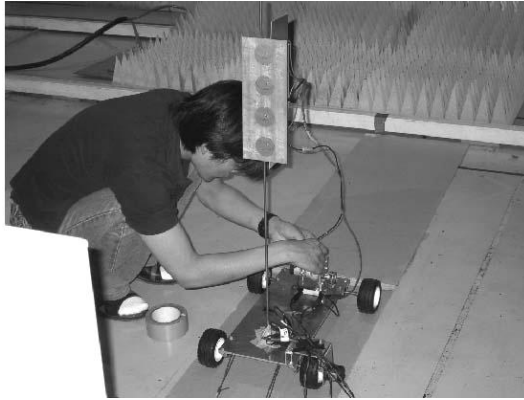

Figure 5 Test model vehicle

EXPERIMENT AND RESULTS

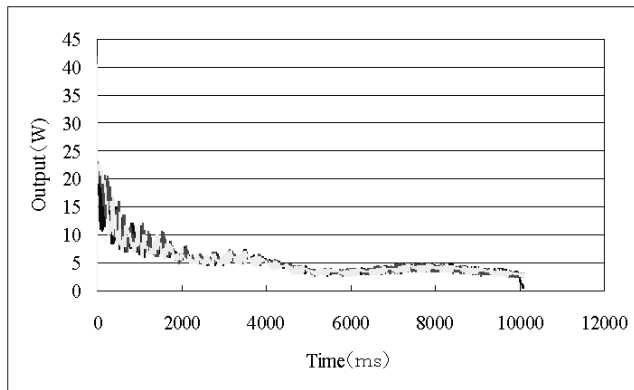

Figure 6 Motor output power of the vehicle

The first experiment was done in a radio wave anechoic chamber of the Microwave Energy Transmission Laboratory (METLAB) of Radio Science Center for Space & Atmosphere, Kyoto University on 30th June 2001. The aim of this experiment was to find whether the model vehicle was driven by the microwave energy, which was transmitted in the air, or not. The horn antenna was fixed and the test vehicle was set to run on a straight line along the centerline of the horn antenna. It means that the vehicle run away from the horn antenna. As the microwave transmitted from the horn antenna had a rather large side lobe, the intensity of the microwave was damped as the distance from the horn antenna

increased. Operating voltage and current controllers outside the experiment chamber, when the output power of the magnetron reached to a set value (for instance 500 W), the monitor showed that **the vehicle surely moved**. This was the first moment in the world that the off-road model vehicle run by the microwave energy. Figure 6 shows the output power variation to the motor of the vehicle. It gradually decreased as the time elapsed. The input power to the rectenna was not measured this time. However, the decrease of rectenna input power due to the distance increase might be the reason of the decrease of motor output power.

CONCLUSIONS

The simple experiment was successfully conducted to drive a small model of agricultural vehicle by the microwave energy which was generated by the magnetron, transmitted by the horn antenna, received and converted to DC power by the rectenna, and drove the motor of the vehicle in June 2001. More detailed and precise experiments are planned to establish a new concept agricultural vehicle, which needs no fuel, has no emission, no battery, but driven by the air-transmitted microwave energy.

REFERENCES

1. MATSUMOTO H. (1995) Microwave power transmission from space and related nonlinear plasma effects. *Space and Radio Science Symposium*, Brussels, Belgium, 155-190, April.
2. NAGATOMO, M., N. KAYA AND H. MATSUMOTO. (1986). Engineering aspect of the microwave ionosphere nonlinear interaction experiment (MINIX) with a sounding rocket. *Acta Astronautica*, 13, 23-29.
3. OIDA A., J. MIYAJIMA, K. OHDOI AND M. YAMAZAKI. (1996). Study on development of an electric tractor. In *Proc. 12th International Conf. ISTVS*, Beijing, China, 699-706 October.
4. SCHLESACK, J.J., A. ALDEN AND T. OHNO. (1988). A microwave powered high altitude platform. *IEEE MTT International Microwave Symposium*, N.Y., Vol.I, 283-286.



DISTRIBUTION OF DRIVING MOMENTS AND PULLS ON TRACTOR AND SEMI-TRAILER WHEELS

JOZEF SEMETKO, IVAN JANOSKO, PETER PERNIS

Slovak agricultural University
Faculty of Agricultural Engineering
Department of Vehicles and Heat Devices
Nitra, Slovakia

SUMMARY

The solving multidrive vehicles, tractors and trailers come out of the assumption, that the contact conditions under all wheels are the same. In agriculture this condition is but seldom realised. Therefore the dependence expressing the distribution of driving moments and pulls of the single wheels has been derived under the most different contact conditions. The experiments confirmed various drawbar pulls of separate drive combinations 8W2D, 8W4D and 8W8D in dependence on the loading force, the radius of wheels and the coefficient resistance rolling.

Key words: tractor, trailer, wheels, distribution of driving moments and pulls

INTRODUCTION

The operating conditions in agriculture are characterised by variability of the micro and macrochanges of landscape, what evoke the changes of drawbar tractor properties. The quality of contact conditions determinate ability of driving wheels to transfer the energy of engine at working unit.

In standard tractor set with trailer, the weight of transport load isn't utilised at increase the drawbar pulls of cat. The trailer but partially loaded the cat and enables as increase drawbar pulls of cat, what is analysed in following paper.

Our analysis the drive wheels of trailer come out of papers by authors: Bajla, Malý (1999), Grečenko (1994), Komandi (1999), Ksenevič, Rusanov (2000), Žikla (1994).

THEORETICAL ANALYSIS

At the logical analysis we can suppose, that tractor with trailer or semi-trailer compose solid systém. It follows, that real speeds all wheels v_l until v_n are equivalent. We must accept the theorem, that under all wheels of tractor and trailer can be the different contact conditions and consequently theoretical speeds v_{l1} until v_m can be diferent. Anyone wheel of tractor can have a divers slip. Therefore we can for fouraxles tractor set (8W8D), as is shown in Fig.1, write:

$$v = v_1 = v_2 = v_3 = v_4 = v_5 = v_6 = v_7 = v_8 = v_{t1}(1 - \delta_1) = v_{t2}(1 - \delta_2) = v_{t3}(1 - \delta_3) = v_{t4}(1 - \delta_4) = v_{t5}(1 - \delta_5) = v_{t6}(1 - \delta_6) = v_{t7}(1 - \delta_7) = v_{t8}(1 - \delta_8)$$

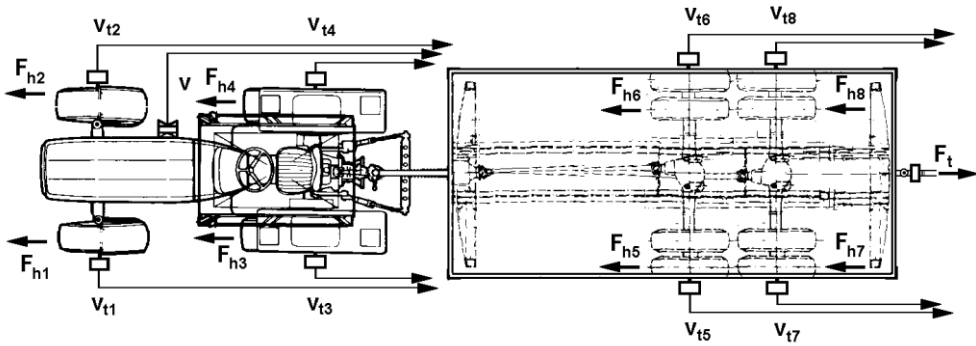

Figure 1. Schema tractor set with semi-trailer

Different slip of wheels equalise differences between their actual and theoretical speed. Also for these different contact conditions we find in dependences $\delta_i = f(F_{t,i})$ such points, in those guidlines of tangent to curves of slip each wheel are equivalent for all eight wheels. These dependencies for four drive wheel is shown in Fig.2. In sense presented hypothesis between slip of each wheel δ_i , and them corresponding driving forces F_{hi} , it's a dependence:

$$tg \alpha = \frac{d \delta_{h1}}{d F_{h1}} = \frac{d \delta_2}{d F_{h2}} = \frac{d \delta_3}{d F_{h3}} = \frac{d \delta_4}{d F_{h4}} = \frac{d \delta_5}{d F_{h5}} = \frac{d \delta_6}{d F_{h6}} = \frac{d \delta_7}{d F_{h7}} = \frac{d \delta_8}{d F_{h8}} \quad (2)$$

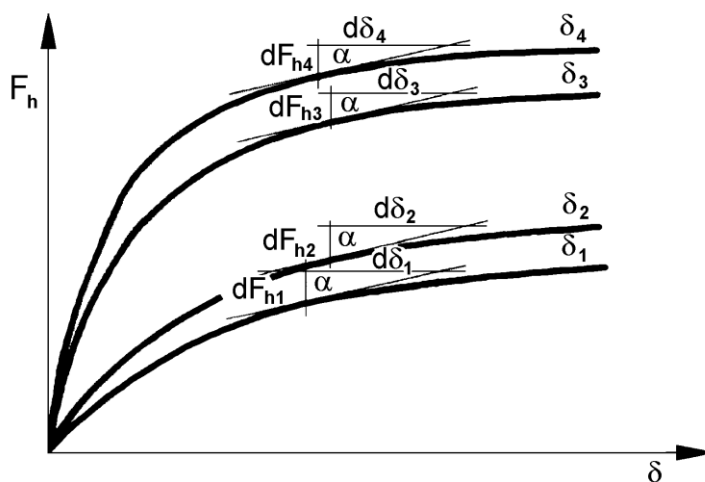

Figure 2. Dependencies of driving pulls wheels on slippage

Based on known dependences between parameters and technical-exploitation properties of tractor, we can deduce for different slip of driving wheels δ_1 until δ_8 , for different coefficient of rolling resistance of each wheel f_1 until f_8 and for dynamic radii these wheels r_1 until r_8 , for dynamic load these wheels $Y_{1L} - Y_8$ follow sectionalise of driving moment $M_{h1} - M_{h8}$ on the separated wheels or axle :

$$M_{h1} = M_{h2} \cdot \frac{r_1 \cdot \delta_1}{r_2 \cdot \delta_2} + \frac{r_1}{\delta_2} (Y_1 \cdot f_1 \cdot \delta_2 - Y_2 \cdot f_2 \cdot \delta_1) \quad (3)$$

$$M_{h7} = M_{h8} \cdot \frac{r_7 \cdot \delta_7}{r_8 \cdot \delta_8} + \frac{r_7}{\delta_8} (Y_7 \cdot f_7 \cdot \delta_8 - Y_8 \cdot f_8 \cdot \delta_7) \quad (4)$$

Analogical we can express also a ratio of partial driving forces of individual wheels or axles:

$$F_{h1} = F_{h2} \cdot \frac{\delta_1}{r_2 \cdot \delta_2} + \frac{1}{\delta_2} (Y_1 \cdot f_1 \cdot \delta_2 - Y_2 \cdot f_2 \cdot \delta_1) \quad (5)$$

$$F_{h7} = F_{h8} \cdot \frac{\delta_7}{r_8 \cdot \delta_8} + \frac{1}{\delta_8} (Y_7 \cdot f_7 \cdot \delta_8 - Y_8 \cdot f_8 \cdot \delta_7) \quad (6)$$

OBJECT AND EXPERIMENTAL METHODS

Experimental tractor set was composed with: Tractor Z-7745, semi-trailer (6 t) with driving two-axle adapted from commercial vehicle (Fig. 3). Measured tractor set had following technical parameters:

- weight of tractor / weight at rear axle	4200 /2720 kg
- nominal power engine / nominal operating speed	49/2200 kW/min ⁻¹
- maximal torque / operating speed at Mk max	246/1600 Nm/min ⁻¹
- trailer hitch – height above ground / distance from rear axle	0,725/0,77 m
- wheelbase	2,23 m
-weight of trailer / load	2250/3000 kg

Drawbar ability of tractor set with semi-trailer we detected by special dynamometric vehicle. The modified Liaz vehicle with hydrostatic brakes was used as a loading vehicle. We measured the slip of drive wheels, actual speed, loading force and rolling resistance of tractor and semi-trailer too. The goal of experiment was detected the influence of driving wheels semi-trailer on the drawbar force of tractor set.

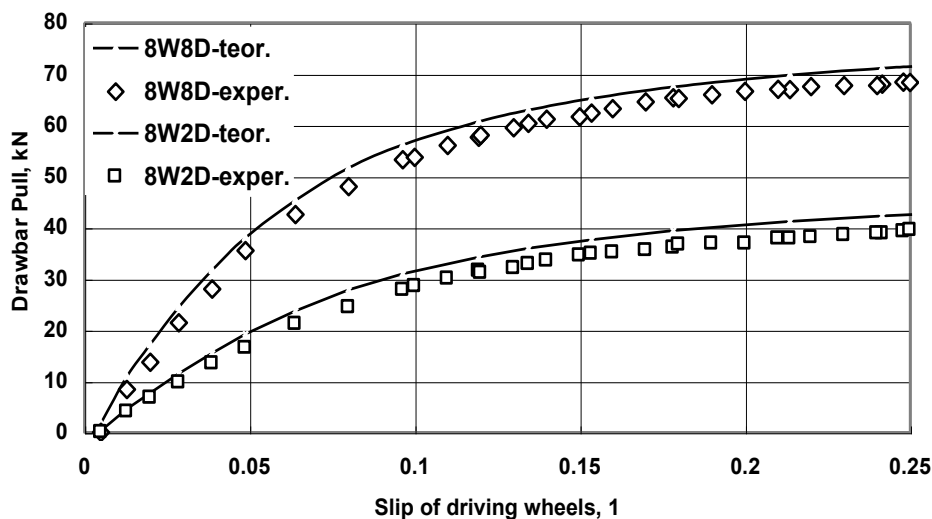

Figure 3. Comparison the experimental and theoretical drawbar pulls

The contact conditions we characterised directly by the slip of driving wheels, which dependent at the quality contact base and load driving wheels. Recorded instantantaneous

values drawbar pulls and slip we elaborated by mathematical filtration. Dependence drawbar pulls on a slip for 3 variant of loaded tractor set is presented in fig.4 and 5. We tested tractor set with drive only back wheels of tractor (8W2D), tractor set with drive first and back wheels (8W4D) as well as set with drive all wheels of tractor and semi-trailer too (8W8D).

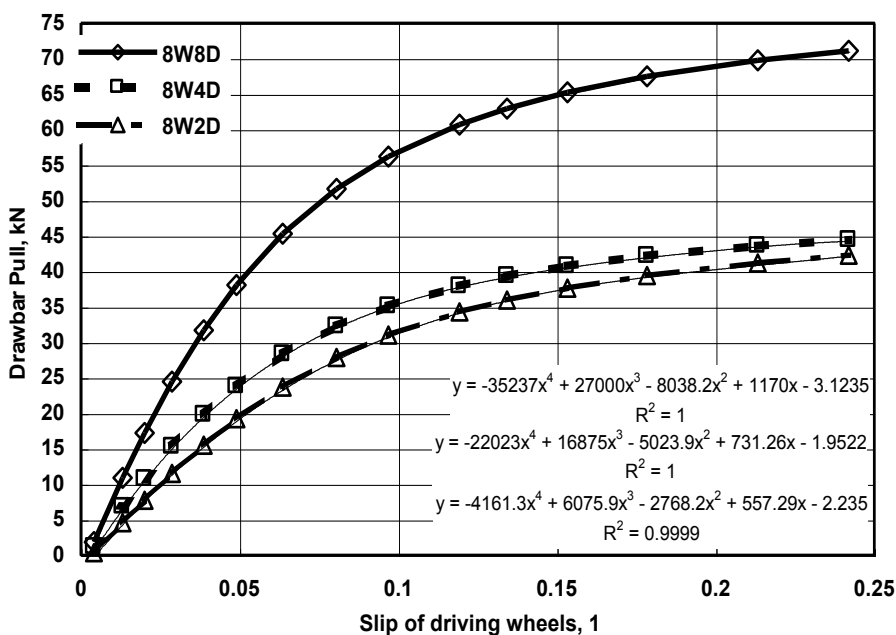

Figure 4. Dependence of theoretical drawbar pulls on slippage

The calculation of slip δ in dependence on contact condition was realized according to gradient formula (7). Contact conditions we characterised by the coefficient of shoot μ given by the ratio driving force F_h and normal loading wheel Y_h , next limit coefficient of shoot μ_m (blocked wheel) and characteristic slip for typical base :

$$\delta = \frac{\delta_k}{2\mu_m} \cdot \frac{3\mu_m \cdot \mu - 2\mu^2}{\mu_m - \mu} \quad \text{where} \quad \delta_k = \frac{j_k}{l} \quad (7)$$

RESULTS

The used model calculations of slip in dependence on driving or drawbar pulls was verified by experimental results. The comparison of courses present good accordance between theoretical and experimental dependences drawbar pulls on slip (Fig.3) as all driving wheels (8W8D) as well as driving back wheels only (8W2D). Increase drawbar pulls increase also difference between calculated and experimental results. Lower obtained drawbar pulls at experiment we can append to difference of asphalt surface test road opposite to beton road for standard condition of calculations.

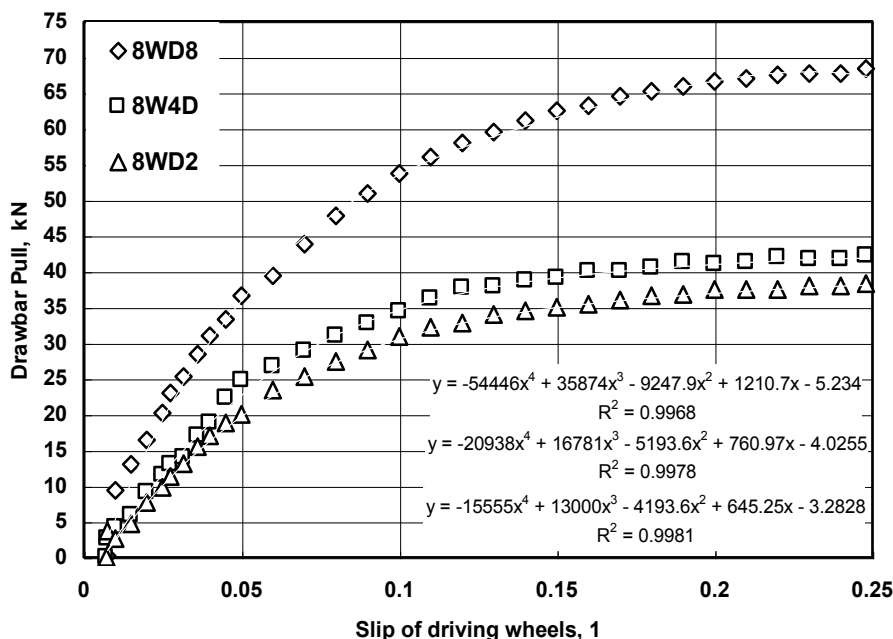

Figure 5. Dependence of experimental drawbar pulls on slippage

The comparison theoretical and experimental results we regarded by means of regression analysis - fitted curves (Fig.4 and 5) according to multi-nominal fourth grades. Experimental results regarded by regression analysis (Fig.5) showed high regression dependence, R² (from 0,9968 to 0,9981). Specific difference between theoretical and experimental values drawbar pulls we can append to difference between considered and real contact conditions of tested road.

CONCLUSIONS

From theoretical analysis follow, that single driving wheel multidrive mechanism can transfer at same value of slip different large driving forces and consequently different drawbar pulls too. The used mathematical model calculations of driving forces or pulls in dependence on slip, enables to express max. available pulls for different contact conditions multidrive tractor set. The results of verification of model calculations drawbar pulls for experimental mobile set enables generalization these information, their application in another operating condition - at others base.

REFERENCES

1. BAJLA, J., MALÝ, V.: (1999) Návrh zariadenia na zisťovanie pôdných vlastností prostým tlakom vpoľných podmienkach. In: Acta technol. agriculturae, roč.2., s. 18-21.
2. GREČENKO, A.: (1994) Vlastnosti terénnych vozidel. ISBN 80-213-0190-2. VŠZ Praha, Vydav. H&H, 118 s.
3. KOMANDI, G.: (1993) Reevaluation of the adhesive Relationship between the Tire and the Soil. Journal of teramechanics, 30, 2 p. 77-83
4. KSENEVIC, I.P., RUSANOV, V.A.: (2000) Problema vozdejsvija dvižitelej na počvu. ISSN0235-8573. Traktory isel'choz. mašiny, N.1
5. ŽIKLA, A.: (1994) Kinematická asilová analýza trojstupňového násobiča krútiaceho momentu. In: Acta technol. agriculturae XXXIV, s. 163-172.



MEASUREMENT AND MODELLING OF THE TYRE–SOIL INTERACTION OF AGRICULTURAL TYRES ON FIRM AND YIELDING GROUND

V. SCHLOTTER

Hohenheim University
Department of Agricultural Engineering
Stuttgart, Germany

SUMMARY

At the Institute of Agricultural Engineering at Hohenheim University several test stands have been built up for investigations of agricultural tyres. The dynamic characteristics in vertical and longitudinal direction have been determined with a flat-belt tyre test stand. Results show a progressive increase of the tyre stiffness with rising deflection and a decrease of the damping coefficient with increasing speed. The behaviour can be described by a non-linear tyre model. For investigations under working conditions, a Single Wheel Tester has been built up. Due to the increasing share of transportation and the use of wide low-pressure tyres in recent years research was focused on the non-steady-state lateral forces on solid ground. A remarkable time delay in force generation was found for a quicker change of the slip angle. The dynamic lateral behaviour can be described with the Maxwell-model. With the results of the flat-belt tyre test stand and the Single Wheel Tester an entire description of the tyre – road interaction is provided for use in vehicle dynamic simulation.

With a laser measuring device the internal contour of the tyre in the tread and in the sidewall can be determined. Thereby the shape of the contact area can be calculated for the rolling tyre. First results show that the tyre contour is not only deformed in the contact area but also displaced upwards outside the contact area. Additionally a predeformation can be stated, which is not taken into account by existing tyre models for the contact area calculation.

Key words: Flat-belt tyre test stand, Single Wheel Tester, dynamic tyre behaviour, tyre contour

INTRODUCTION

Tyres are the link between vehicle and ground and therefore of special interest for the driving behaviour of vehicles. Especially for tractors and agricultural machinery which are used for transportation and field work there are various partial contrary demands. For increasing transportation speeds the spring and damping parameters are of particular importance. The driving safety and comfort of these almost unsprung vehicles are significantly influenced by the spring and damping parameters. An evaluation has to consider the dynamic properties of the tyres in vertical, longitudinal and lateral direction. The dynamic parameters are influenced by the design of the tyre, the tyre parameters such as inflation pressure and tyre load and the soil parameters. An improvement of the driving safety and comfort of agricultural machinery requires the knowledge of the spring and damping parameters.

For field work a good horizontal force transmission is needed for high drawbar pull and lateral stability. Steady state forces e.g. drawbar pull occurs while working with pulled implements whereas lateral forces occur while driving on slopes. The prediction of tyre force generation requires the knowledge of the area and the shape of the contact zone. On solid ground such as asphalt or concrete the deflection of the ground is generally negligible. In this case only the tyre is deformed and the contact area is planar. On yielding ground the soil also is deformed and the exact shape of the contact area is difficult to determine. Therefore at the University of Hohenheim a laser measuring device has been built up to investigate the internal contour of an agricultural tyre.

METHODS

At the Institute of Agricultural Engineering at Hohenheim University several test stands have been built up for investigations of agricultural tyres. For the determination of the vertical dynamic characteristic of agricultural tyres the ground should be exactly even, so the stimulation of the ground is excluded. Therefore in 1978 a flat-belt tyre test stand was developed [1].

Flat-belt tyre test stand

The tyre is guided in a rocker-arm and rolls on a 60 cm wide steel belt which is stuck with sandpaper with grain size 40 in order to simulate a road roughness. The shape of the rocker has been modified later, Figure 1 [2, 3].



Figure 1. Flat-belt tyre test stand

The steel belt itself is driven by one steel roller with a direct current motor. The driving speed is continuous variable from 0 to 62 km/h. On the top of the rocker-arm weights can be fixed to set the tyre load. Under the contact area of the tyre the steel belt is supported by a teflon-coated steel plate. To lubricate the steel belt a water-oil-emulsion is pumped through a lot of drillings into the gap between belt and plate. Under the steel plate three load cells are positioned for the determination of the vertical forces. The horizontal forces are recorded by two force-measurement bolts in the bearing of the rocker-arm which is positioned in the tread level of the tyre. Furthermore the speed of the belt and the tyre, the rolling radius and the angle of rotation are recorded. Besides that a pneumatic brake can be added, to decelerate the tyre [4].

For the determination of the tyre stiffness and damping the tyre is lifted up with a crane, so that it is still in contact with the belt and runs with the belt velocity. Afterwards the tyre is released and oscillates towards its steady position.

Single Wheel Tester

For investigations of agricultural tyres under working conditions, a Single Wheel Tester has been built up, Figure 2 [5]. The test rig is towed by a tractor and mounted in the lower links. The movement of the gage wheel is adjusted by three hydraulic circuits. In the first circuit the hydraulic power is supplied by a hydraulic motor and transmitted to the wheel by a planetary gear. In this way, the wheel can be propelled and decelerated continuously variable. By removing the planets from the planetary gear, the towed wheel can be

investigated. The second circuit controls the tyre load of the gauge wheel by a hydraulic cylinder. With a piezoelectric wheel dynamometer the tyre load of the tyre is simultaneously measured and automatically controlled. Finally the third hydraulic circuit is used to set the steering angle of the wheel. With two potentiometers the steering angle of the gauge wheel and the drift angle of a trailing wheel are measured. The difference of both values results in the actual slip angle of the gauge wheel. Since high lateral forces make the test rig move sideways, the steering angle is also adjusted at the same time. Further output signals are impulses of the incremental shaft encoders mounted on the gauge wheel and the trailing wheel leading to the actual value of slip. This allows to run the gauge wheel under different conditions, i.e. steady state and non-steady-state slip.



Figure 2. Single Wheel Tester

Laser measuring device

The Single Wheel Tester provides good prerequisites for the measurement of the deformation of a tyre. Since the measurement of the external contour is very difficult to realize, an internal measuring device was built up, Figure 3. By a laser distance sensor the distance to the internal contour of the tyre can be measured. The device consists of a carrier which is fixed to the rim and therefore rotates with the tyre. The laser distance sensor, a stepper motor and a rotary encoder are mounted on the carrier. With the stepper motor the laser sensor can be swivelled in lateral direction up to a swivel angle of $\beta = 85^\circ$ starting

from the vertical position. The rim has several assembly openings, since the carrier has to be assembled on the rim after the tyre has been mounted. A slip ring was used for transmission of the measured data. The rotation angle of the wheel is determined by an incremental encoder which is also used for measuring the velocity of the wheel and the wheel slip.

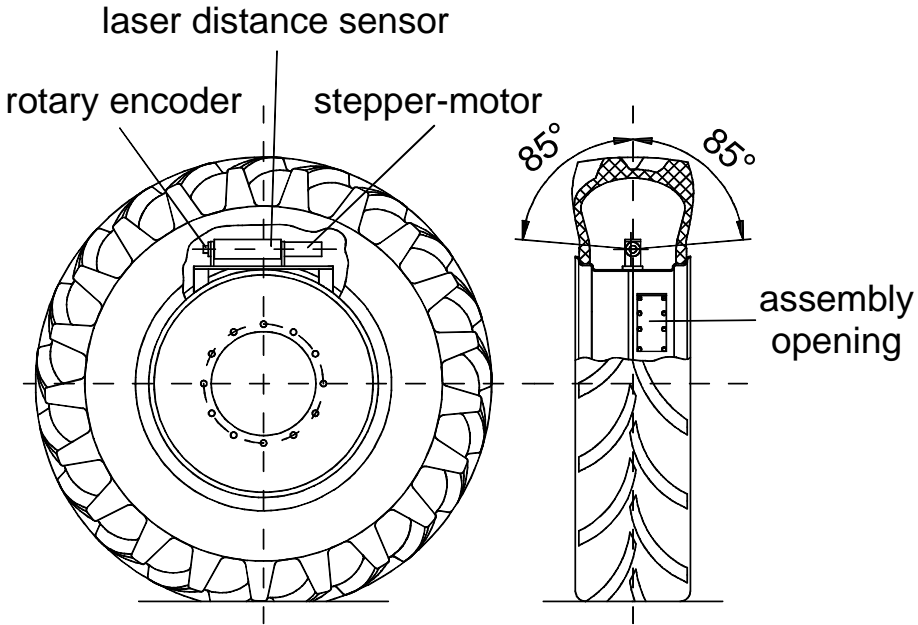

Figure 3. Laser measuring device

RESULTS

Spring and damping characteristics

For a description of the dynamic tyre characteristics the tyre forces and their correlating displacements have to be known. In vertical direction the interaction between the vertical tyre force and the vertical deflection is of importance. With a tyre deflection test and the simultaneous measurement of the vertical forces the spring and damping characteristics can be determined, Figure 4.

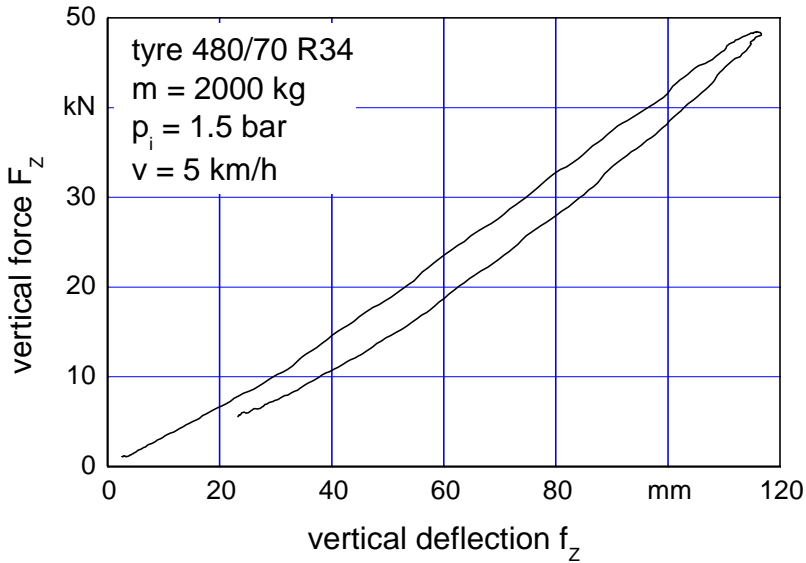

Figure 3. Hysteresis loop for the vertical direction

At the University of Hohenheim a non-linear tyre model for the vertical direction was developed [2, 6]. Based on the Voigt-Kelvin-model, the total vertical force is the sum of the spring and the damping force:

$$F_{Rz} = F_{Cz} + F_{Dz} \quad (1)$$

As Figure 4 shows, the spring force is not linear but can be approximated by a power function:

$$F_{Cz} = c_{1z} \cdot f^{c_{2z}} \quad (2)$$

The damping force F_{Dz} depends linearly on the vertical deflection speed:

$$F_{Dz} = d_{Vz} \cdot \dot{f}_z \quad (3)$$

The spring and damping parameters c_{1z} , c_{2z} and d_{Vz} are calculated by approximation of a tyre deflection test. Based on test runs, Plessner further on developed the model for the longitudinal direction [3].

The influence of tyre size and design, inflation pressure, rolling velocity and tyre load on the model parameter have been investigated [7, 8, 9]. Exemplarily the model parameter for different water filling level is shown. In accordance to former works, the spring and damping parameters decline with increasing rolling speed, Figure 4. All parameters drop up to 15 km/h and are almost constant for higher speeds. Due to the conversely proportional dependence of damping and excitation frequency [10], the damping decreases degressively with increasing rolling speed.

No dependency was found between the damping and the amount of water ballasting, but the spring stiffness strongly depended on water filling [11]. The hardening of the tyre can be explained through the mass of the water in the tyre. Additionally, the suspension-giving

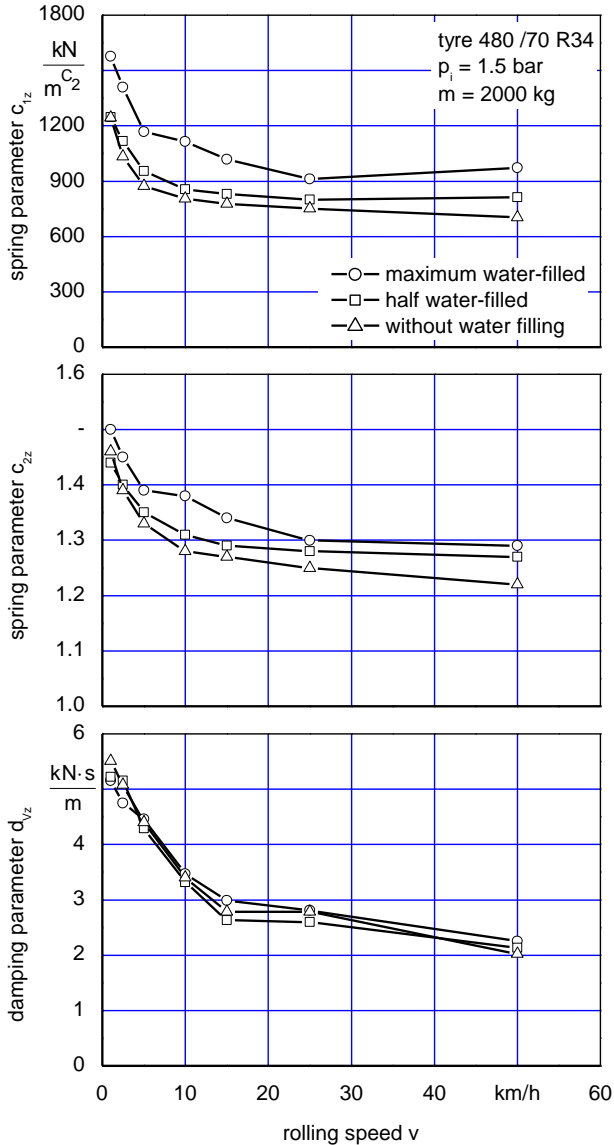

Figure 4. Spring and damping parameters depending on the water filling level

volume of air within a tyre is reduced in a water-filled one which leads to a further hardening.

The dynamic behaviour of agricultural tyres is described more precisely by the non-linear tyre model than by the Voigt-Kelvin-model. The empirical formulation of the vertical and longitudinal tyre-road-interaction can be used favourably for tractor dynamic simulations.

Drawbar pull measurements

Measurements of longitudinal forces, i.e. drawbar pull or rolling resistance, have been subject of many investigations [12, 13, 14]. With the Single Wheel Tester, the drawbar pull generation up to a slip of about 60% can be measured, Figure 5. The drawbar pull increases with higher slip, but decreases after reaching a maximum. The zero condition of the wheel slip is problematically and not standardised [15, 16, 17], in this Figure the convention of Barreilmeyer has been used [21]. Therefore, the rolling resistance was taken into account to determine zero slip.

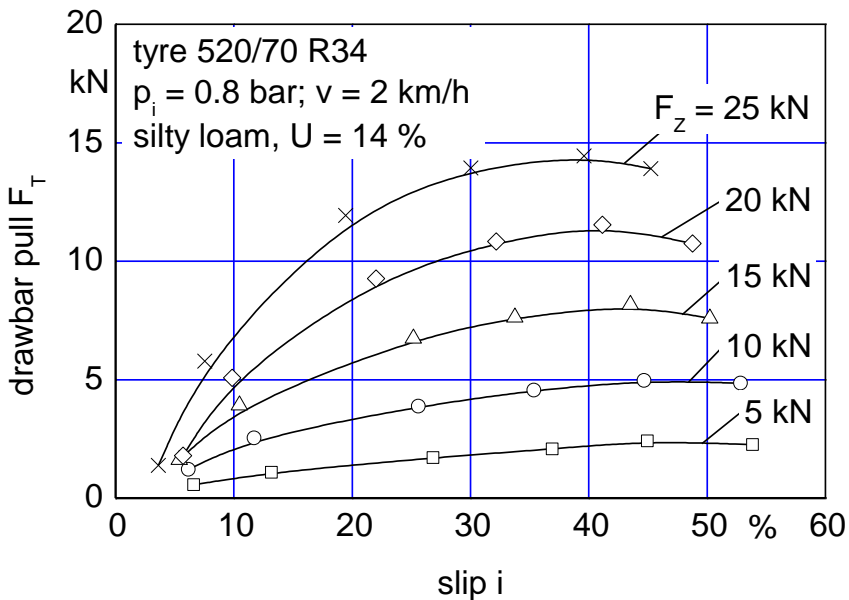

Figure 5. Influence of slip and tyre load on the drawbar pull generation

Due to the large number of investigations concerning measurement of drawbar pull and the traction prediction [18, 19, 20], in recent years the work at Hohenheim University was focused on the generation of lateral forces and the interaction of horizontal tyre forces [21, 22].

Lateral force measurements

The measurement of steady state lateral forces on yielding ground has been subject of many papers [21, 22, 23]. Based on measurements, different tyre models for the prediction of steady state lateral forces have been developed [24, 25, 26, 27].

Due to the increasing transportation speeds combined with the use of wide, low pressure tyres a further investigation of the driving safety is required. Especially the lateral force generation of agricultural tyres on firm ground influences the driving safety to a high degree. The non-steady-state force generation is decisive for vehicle dynamics e.g. during steering movements, where the slip angle is not constant. A comparison of steady state and non-steady-state measurements has shown, that a steady state condition cannot describe the dynamic lateral behaviour of wide tractor tyres [30].

The lateral force behaviour for constant slip angles depending on the tyre inflation pressure is shown in Figure 6. Especially for small slip angles, which are important for driving dynamics, the lateral force is increased by lowered inflation pressure. For the constant slip angle the forces mainly depend on the size of the contact area. Measures that increase the contact area improve the lateral force generation for small slip angles. For higher slip angles the tyre gets unstable at lowered inflation pressure and the force generation is deteriorated.

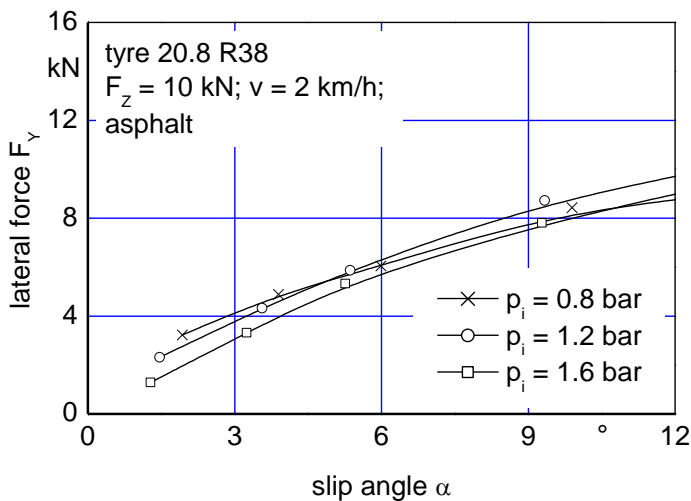

Figure 6. Steady state lateral force – slip angle behaviour in dependence of the inflation pressure

Investigations with constant slip angle are important for an assessment of steady state conditions, i.e. driving on slopes, but it is not sufficient for vehicle dynamics. During transport the steering angle is often modified in order to follow the course of the road. Therefore measurements were carried out with non-steady-state slip angle excitation. The

slip angle was adjusted from 0° to 15° with a constant slip angle changing speed. This situation is typical for turning into a curve. Figure 7 shows, that the force generation for the non-steady-state setting increases for higher inflation pressure. This result is in contrast to the steady state condition. The higher stiffness of the tyre for higher inflation pressure reduces the delay in force generation.

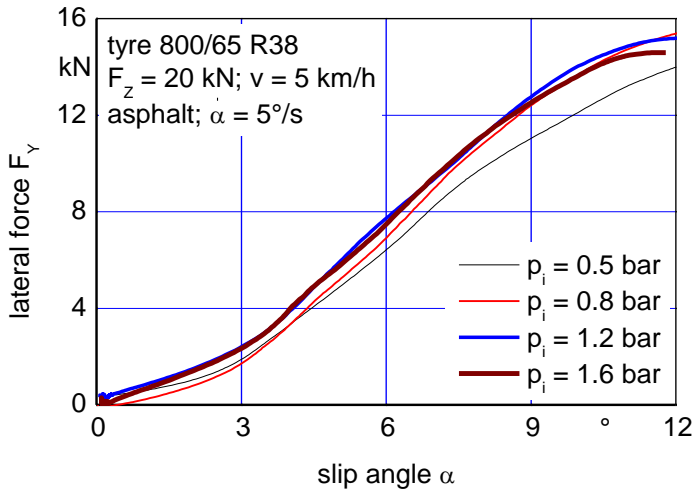

Figure 7. Non-steady-state lateral force – slip angle behaviour in dependence of the inflation pressure

For a detailed determination the tyre was steered by a sinusoidal slip angle. Thereby the amplitude as well as the phase of the slip angle and the lateral force have been measured. The measured data corresponds very well with the results of the Maxwell-model [29, 30]. With this model the dynamic behaviour is described in lateral direction in addition to the non-linear tyre model of Langenbeck and Plesser in vertical and longitudinal direction. Since the Maxwell-model is a serial spring – damper model, it is characterised by the spring and damping parameters c_Y and d_Y , Table 1.

Table 1. Influence of the tyre inflation pressure and the driving velocity on the lateral spring and damping parameters on asphalt

	tyre	tyre load F_Z [kN]	inflation pressure p_i [bar]	velocity v [km/h]	spring parameter c_Y [kN/m]	damping parameter d_Y [kN·s/m]
influence of inflation pressure	800/65 R32	20	0.5	5	128.9	147.5
			0.8		163.9	160.2
			1.2		165.0	182.3
			1.6		175.0	133.0
influence of velocity	20.8 R38	20	0.8	2	117.7	274.6
				5	145.7	117.1
				10	165.6	43.6

With increasing inflation pressure the spring parameter rises, whereas the damping parameter does not show a clear tendency. This increase of spring stiffness results from the higher inflation pressure in the tyre. For higher driving velocity the lateral stiffness of the tyre is raised, whereas the damping deteriorates considerable. These tendencies are in accordance to the spring and damping parameters in vertical and longitudinal direction. With this model an entire description of the dynamic tyre-ground interaction including a database for agricultural tyres is available.

Measurements of the internal contour

The internal contour of the tyre with size 520/70 R34 has been measured on firm and yielding ground for the non-rolling tyre, Figure 8. The plot shows the recorded distance of the laser sensor being rotated by the stepper motor in cross direction. The curves in the left part of the plot show the results of measurements on concrete and the ones on the right side the results on sandy loam. For the unburdened tyre there is a slight difference between the measurements on concrete and sandy loam being caused by variances and scattering. For higher tyre loads the tyre is more deflected and flattened. The distance of the laser sensor is lessened in the centre of the tyre and the sidewall is bulged. On concrete the deflection is higher compared to sandy loam due to the rigid surface in contrast to yielding ground. Additional measurements have shown, that especially on solid surface the lugs become detectable on the internal contour of the tyre. Therefore the curves of the burdened tyre do not run parallel to the horizontal road surface. The laser measuring device shows this tendency more obviously with increasing tyre inflation pressure, since the number of lugs is smaller for a reduced contact area. For high tyre deflections the reflection of the laser beam is insufficient and causes false signals.

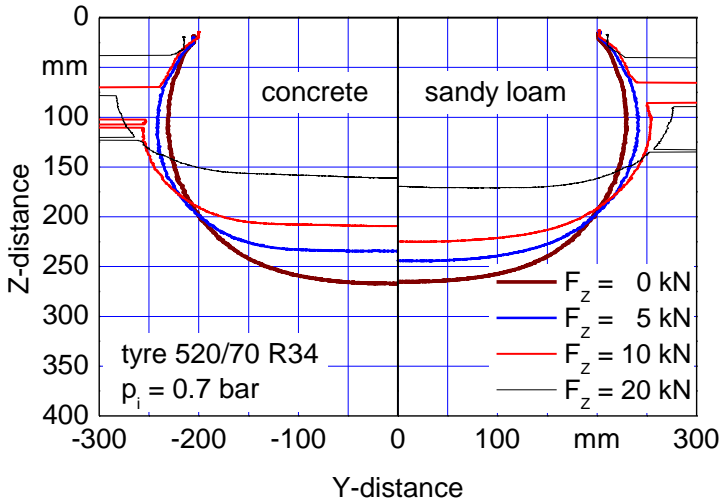

Figure 8. Internal contour of the tyre in the Y-Z-plane

In Figure 10 the contour of the rolling tyre for one wheel revolution is shown. The circular, unburdened contour is drawn as broken line. The external contour is calculated basing on the internal contour and the height of the carcass. Therefore the elasticity of the tread and the lugs are neglected.

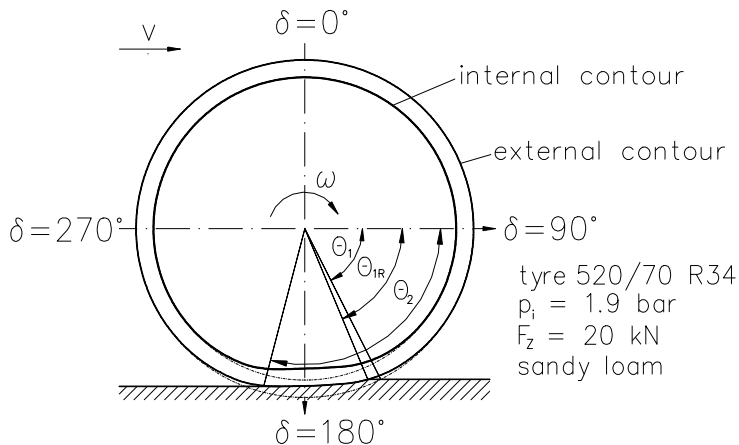

Figure 9. Deformation of the rolling tyre

Most predictions of tyre forces on yielding ground are based on the knowledge of size and shape of the contact area. The form of the tyre is predicted as circular outside the contact area basing on the tyre diameter. The front- and the rear angle Θ_1 and Θ_2 characterise the entrance and the exit point of the contact area. The contact area is generally approached by the arc of an enlarged circle [31], a parabola [32], a spiral or a combination of several elements [33]. A comparison of the measured internal contour with calculated segments shows only slight differences between those models. For the large agricultural tyres used in this investigation the contact length is short compared to the tyre diameter. The shape can be approximated by circle arcs as well as parabolas or spirals. Due to the displacement of the tyre and the predeformation outside the contact area, the entrance point of the tyre into the contact area is shifted to the real front angle Θ_{1R} . The contact area is diminished compared to a circular approach of the tyre outside the contact area. Physical-traction-prediction-models for large tyres have to take this into account to determine the position and size of the contact area more precisely. Especially for large agricultural tyres, for which the ratio of contact area and rolling circumference is very small, the impact on the quality of the prediction of tyre forces is considerable.

A detailed view of the deformation of the rolling tyre is given in a Figure 10, where the distance signal of the laser sensor on sandy loam is plotted versus the rotation angle of the wheel. Compared to the distance l_0 of the unburdened tyre, the whole contour of the burdened tyre is displaced upwards. In the upper part of the tyre the contour is displaced outwards. In the range of $\delta = 90^\circ$ and $\delta = 270^\circ$ the contour is supplementary raised due to the displacement of the rubber material in front and after the contact area. The inward deformation starts at the angle δ_1 and ends with δ_2 . Taking into account to the distance of the internal and the external contour, the calculated external tyre deformation has an arc length of about 2 m on the tyre circumference.

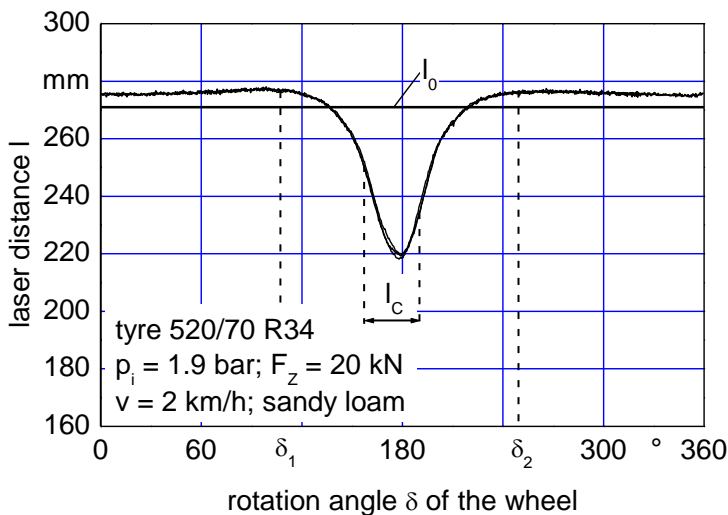

Figure 10. Internal contour of the rolling tyre

A determination of the contact length l_C on yielding ground is more difficult. The contact length of the rolling tyre is not comparable to the contact length measured for the non-rolling tyre since only the front range of the tyre is concerned. If the elastic reformation of the soil is neglected, the contact area starts at the entrance point of the tyre in the soil and ends when leaving the deepest point, which is not situated at a rotation angle of $\delta = 180^\circ$, as shown in Figure 10. The calculated length is $l_C = 0.45$ m, which is less than the tenth part of the rolling circumference of the tyre.

CONCLUSION

At the Institute of Agricultural Engineering of the University of Hohenheim several test stands have been developed for the investigation of the tyre-soil respectively the tyre-road interaction of agricultural tyres. With the measured data the description of the tyre forces and their correlating displacements could be improved. For use in vehicle dynamic simulations tyre models have been set up and evaluated for vertical, longitudinal and lateral direction.

With the laser measuring device the internal contour of the tyre can be measured. The knowledge of the exact size and shape of the contact area is required for physical traction prediction models that are based on the description of the force distribution between tyre and ground.

Considering the high demands concerning driving velocity, load capacity and traction and the changing general conditions regarding soil protection and conservation, the research activities will be continued.

REFERENCES

1. SCHROGL, H.: (1989) Dynamische Eigenschaften von Ackerschlepper-Triebradreifen bei höheren Rollgeschwindigkeiten. Forschungsbericht Agrartechnik der MEG, Nr. 159, Dissertation, Universität Hohenheim.
2. LANGENBECK, B.: (1992) Untersuchungen zum Fahrverhalten von Ackerschleppern unter besonderer Berücksichtigung der Reifeneigenschaften. Dissertation, Universität Stuttgart, VDI Fortschritt-Berichte, Reihe 14, Nr. 55.
3. PLESSER, J.: (1997) Dynamisches Verhalten von Ackerschlepperreifen in Vertikal- und Längsrichtung auf fester Fahrbahn. Dissertation, Universität Stuttgart, VDI Fortschritt-Berichte, Reihe 14, Nr. 83.
4. PLESSER, J.: (1994) Longitudinal dynamics of agricultural tyres. Proceedings of the 6th European ISTVS Conference, Vienna, Austria Vol. 1, pp. 263-276.
5. ARMBRUSTER, K.: (1989) Development of a single wheel tester for measurements on driven angled wheels. Proceedings of the 4th European ISTVS Conference, Wageningen, Netherlands, Vol. 1, pp. 8-14.
6. KUTZBACH, H.D.: (1994) Investigations on tractor tyres test stands and results. Proceedings of the 6th European ISTVS Conference, Vienna, Austria, Vol. 1, pp. 219-237.
7. LANGENBECK, B.: (1991) Reifenkennwerte. Kennwerte für ein nichtlineares Reifenmodell. Landtechnik 46 H. 5, pp. 221-224.
8. PLESSER, J.: (1996) Investigations on Agricultural Tyres – Spring and Damping Parameters. Proceedings of the 1st International Conference of Off-Road Machines and Vehicles in Theory and Practice, Wroclaw, Poland, pp. 167-173.
9. PLESSER, J.: (1997) Longitudinal Tyre Parameters – measurement results. Proceedings of the 7th European ISTVS Conference, Ferrara, Italy, pp. 580-587.
10. MITSCHKE, M.: (1995) Dynamik der Kraftfahrzeuge, Band A: Antrieb und Bremsung. Springer Verlag Berlin, Heidelberg, New York, Tokyo,.
11. BERNHARD, B., V. SCHLOTTER AND H.D. KUTZBACH: (2001) Spring and Damping Characteristics of Water-filled Tyres. ASAE-paper No. 01-1133, pp. 1-7.
12. JANOSI, Z.: (1961) An analysis of pneumatic tire performance on deformable soils. Proceedings of 1st International Conference of ISTVS, Turin, Italy, pp. 737-771.
13. STEINKAMPF, H.: (1986) Betriebseigenschaften von Ackerschlepperreifen bei unterschiedlichen Einsatzbedingungen. Landbauforschung Völkenrode, Sonderheft 80.
14. DWYER, M.J., D.R. COMELY AND D.W. EVERNDEN: (1974) The field performance of some tractor tyres related to soil mechanical properties. Journal of Agricultural Engineering Research 19, No. 1, pp. 35-50.
15. SCHÜRING, D.: (1969) Zur Theorie des Geländerades. Forschung im Ingenieurwesen Bd. 34 (1968) No. 6, pp. 165-176 and Bd. 35 No. 1, pp. 7-11.
16. STEINKAMPF, H.: (1971) Zur Methodik der Rollradien- und Schlupfmessung. Grundlagen der Landtechnik Vol. 21, No. 2, pp. 40-44.
17. SHARMA, A.K. AND K.P. PANDEY: (1998) Traction data analysis in reference to a unique zero condition. Journal of Terramechanics Vol. 35, pp. 179-188.

18. UPADHYAYA, S.K.: (1997) A semi-empirical traction prediction equation for radial ply tyres. ASAE-Paper No. 97-1023, pp. 1-9.
19. SHIBUSAWA, S. AND A. SASAO: (1996) Traction data analysis with the traction prediction equation. *Journal of Terramechanics* Vol. 33, No. 1, pp. 21-28.
20. GODBOLE, R., R. ALCOCK AND D. HETTIARATCHI: (1969) The prediction of tractive performance on soil surfaces. *Journal of Terramechanics* Vol. 30, No. 6, pp. 443-459.
21. ARMBRUSTER, K. AND H.D. KUTZBACH: (1991) Combined lateral and longitudinal forces on driven angled tractor tyres. *Journal of Terramechanics* Vol. 28, No. 4, pp. 331-338.
22. BARRELMEYER, TH.: (1994) Forces acting on driven tractor tyres with stationary and instationary slip angles. *Proceedings of the 6th European ISTVS Conference, Vienna, Austria, Vol. 1, pp. 238-262.*
23. KRICK, G.: (1973) Behaviour of tyres driven in soft ground with side slip. *Journal of Terramechanics* Vol. 9, No. 4, pp. 9-30.
24. KREMER, H. AND W. SÖHNE: (1957) Die Seitenführungskräfte starrer, nicht angetriebener Räder. *Grundlagen der Landtechnik*, No. 9, pp. 101-108.
25. GEE-CLOUGH, D. AND M.S. SOMMER: (1981) Steering forces on undriven, angled wheels. *Journal of Terramechanics* Vol. 18, No. 1, pp. 25-49.
26. GREČENKO A.: (1969) Slip and drift of the wheel with tyre on soft ground. *Proceedings of 3rd International Conference of ISTVS, Essen, Germany, Vol. 2, pp. 76-95.*
27. SCHWANGHART, H.: (1968) Lateral forces on steered tyre in loose soil. *Journal of Terramechanics* Vol. 5, No. 1, pp. 9-29.
28. JURKAT, M.P. AND P.M. BRADY: (1981) On a lateral force tyre model for both highway and soft soil conditions. *Proceedings of 7th International Conference of ISTVS, Calgary, Canada.*
29. CROLLA, D.A., EL-RAZAZ, A.S.A., ALSTEAD, C.J. AND C. HOCKLEY: (1987) A model to predict the combined lateral and longitudinal forces on an off-road tyre. *Proceedings of 9th International Conference of ISTVS, Barcelona, Spain, Vol. 1, pp. 362-372.*
30. SCHLOTTER, V. AND H.D. KUTZBACH: (2001) Messung und Modellierung von dynamischen Seitenkräften am Ackerschlepperreifen. *VDI/MEG Tagung Landtechnik, Hannover, pp. 109-114.*
31. CROLLA, D.A., N.L. HORTON AND R.M. STAYNER: (1990) Effect of tyre modelling on tractor ride vibration predictions. *Journal of Agricultural Engineering Research* 47 No. 3, pp. 55-77.
32. SCHLOTTER, V. AND H.D. KUTZBACH: (2000) The lateral force generation of agricultural tyres. *Proceedings of the 8th European Conference of ISTVS, Umeå, Sweden, pp. 95-102.*
33. SÖHNE, W.: (1969) *Agricultural Engineering and Terramechanics. Journal of Terramechanics* Vol. 6, No. 4, pp. 9-30.
34. SCHMID, I.C.: (1993) Inflation pressure control to improve terrain-trafficability a model for simulation. *Proceedings of the 11th International ISTVS Conference, Lake Tahoe, USA Vol. 1, pp. 64-75.*
35. OKELLO, J.A.: (1992) Prediction of the force distribution between the soil and a pneumatic wheel. *Journal of Agricultural Engineering Research* 51, pp. 249-262.

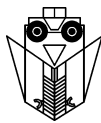

A STABILITY ALARM SYSTEM FOR SMALL FOUR-WHEEL TRACTORS

V. M. SALOKHE, IMAM HIDAYAT

AASE Program
Asian Institute of Technology
Pathumthani, Thailand

ABSTRACT

A stability alarm system, to sense the stability of a tractor and to warn the operator before instability is reached, was developed. The developed transducer can sense the change of ground normal load under the tractor wheel. The alarm will give a warning at a certain level of ground slope, which can be set by varying a reference voltage. The output curve of the stability transducer follows a sine or cosine curve depending upon the heading and tilting angle of the tractor and agrees with the change of ground normal load on the wheel as measured on a weigh-pad. This agreement proved that the developed stability transducer can be used as a sensor to sense the existence of ground normal load on the wheel, which sensed the tractor stability.

Key words: Alarm system, tractor stability, operator safety, small tractors

INTRODUCTION

Modern tractors come with a big ratio of drawbar power to their weight. This condition has led to the longitudinal stability problem, especially when the tractor is operated on sloping grounds and the implement is improperly hitched. In addition to that, the lateral stability also becomes critical when the tractor is operated on sloping ground, especially when the tractor ground clearance is high (Sack, 1956). The increase in tractor accidents led to enforcement on tractor manufacturers, especially in the west, to equip their product with rollover-protective-structures (ROPS). This is not prevalent in developing countries. However, ROPS cannot reduce accidents. It reduces the fatalities. There is a need to sense the stability of a tractor before it reaches an unstable condition. Though many accidents are caused by human errors, machine design also contributes to the situation where a tractor

becomes unstable. The lighter tractors with high horsepower are more susceptible to overturn.

This study was aimed to develop a stability alarm system for a commonly used four-wheel tractor in Indonesia by using a strain-gaged sensors and an electronic circuit (Hidayat, 1996). This was done by examining the tractor stability, using simple sensors for sensing its stable or unstable condition, designing and developing the electronic alarm circuit and testing the alarm in the laboratory and field.

METHODOLOGY

Investigation of Tractor Stability

In this study, a Kubota B6100 tractor weighing 4.27 kN (10.7 kW) was used. In order to calculate the tractors static stability angle, a measurement of the tractors center of gravity was done by the weighing method (Liljedahl et al., 1979). The measurements of the tractor's center of gravity location were used to determine the longitudinal stability of the tractor. The angle of longitudinal stability (β_{long}) can be calculated using the following equation.

$$\beta_{\text{long}} = \tan^{-1} \frac{L_{cg}}{H_{cg}} \quad (1)$$

where, L_{cg} = distance of center of gravity ahead of rear axle

H_{cg} = height of center of gravity above the ground level

In examining the lateral stability of a tractor, the wheel tread width was measured. Together with the location of the center of gravity data, the wheel tread width can be used for determining the angle of lateral stability (β_{lat}) by using eqn. (2).

$$\beta_{\text{lat}} = \tan^{-1} \frac{b}{2H_{cg}} \quad (2)$$

where, b = wheel width

Sensing the Instability of Four-Wheel Tractor

The instability of tractor occurs when the wheel just loses contact with the ground and this situation can be sensed by using a strain-gaged sensor. During the first attempt, four strain-gaged sensors were mounted on each end of the axle housing. But this did not work due to asymmetric shape of the axle housing.

Due to above reason, later, transducers were built separately using a cantilever. These transducers were used to sense the instability either longitudinally or laterally by setting the output of the transducer to become zero when there was no ground reaction on the wheel. This was done by lifting up the tractor body using a hydraulic-jack. Calibration of these transducers were done to get a relation between equivalent load in the wheel and output voltage from the transducers. This calibration was done by placing the tractor on weigh-

pads and lifting the tractor body and then lowering it slowly using the hydraulic-jack to get several data points of equivalent load on the wheel versus output voltage from the transducers. The calibration curve was used to determine the reference voltage for the alarm circuit.

Design of the Alarm Circuit

The circuit was designed to determine when the transducers sense the near –instability condition. Defined as the ground reaction, which produces an output equal to the present reference voltage. At this point the circuit will activate the alarm to give a warning to the operator. The strain gages on each transducer were connected in a Wheatstone bridge circuit. The amplified output of this bridge provided an input to a comparator. When there is a load on the axle of the wheel, the active strain gages change its resistance and the bridge gives an output voltage. This output voltage difference causes the comparator to produce a high signal condition. If there is no load on the axle, there is no output produced in the resistive bridge. This condition causes the comparator to produce an output in the low condition.

The comparator outputs from the right and left front axles were fed into an OR-gate (IC 7432) where as comparator outputs from the right and left rear axles were fed into an AND-gate (IC 7408). The outputs from these two gates were then fed into another AND-gate. The output from this final AND-gate determined the alarm rings or not. The complete truth table of all gates can be seen in Table 1.

This arrangement was based on the assumption that the tractor would overturn if the normal ground load on both front wheels was equivalent to or smaller than the reference voltage, or if the normal ground load on either rear wheel was equivalent to or smaller than the reference voltage. These assumptions were based on the front wheel axle construction, which was non-rigid, with a hinge.

In the testing of the alarm system, either in the laboratory or in the field, only the output of the stability transducer was recorded, while the alarm circuit itself was tested separately. Research conducted by Spencer et al. (1985) showed that the overturning slope was about 2 degrees less than the slope at which zero load was predicted to occur. The moment of the ground reaction, almost zero, was set at 5 degrees less than the stability angle in this study in order to test the tractor safely. The alarm of this circuit can be set in any degree of angles, by setting the reference voltage in the comparator. A setting of 5 degrees less than the stability angle could be used to calculate the reference voltage on each comparator.

Testing of the Alarm System in the Laboratory

Using the data of the angles of stability obtained both longitudinally and laterally, the alarm system was tested in static conditions in the laboratory using a tilting and rotating table (Fig. 1). This test provided a comparison between the weigh-pad measurement and the transducer sensing result. For safety, a loose wire rope tied to the rotating table was attached to the tractor wheels to hold the tractor whenever it overturned. Also, the operator used a helmet and seat-belt for safety.

Table 1: The truth table of the alarm system

Comb. No.	Front wheel		OR Gate	Rear wheel		AND Gate	Combine		AND Gate	Alarm Cond.
	Right	Left		Right	Left		Front	Rear		
1	1	1	1	1	1	1	1	1	1	OFF
2	1	0	1	1	1	1	1	1	1	OFF
3	0	1	1	1	1	1	1	1	1	OFF
4	0	0	0	1	1	1	0	1	0	ON
5	1	1	1	1	0	0	1	0	0	ON
6	1	0	1	1	0	0	1	0	0	ON
7*	0	1	1	1	0	0	1	0	0	ON
8	0	0	0	1	0	0	0	0	0	ON
9	1	1	1	0	1	0	1	0	0	ON
10*	1	0	1	0	1	0	1	0	0	ON
11	0	1	1	0	1	0	1	0	0	ON
12	0	0	0	0	1	0	0	0	0	ON
13	1	1	1	0	0	0	1	0	0	ON
14	1	0	1	0	0	0	1	0	0	ON
15	0	1	1	0	0	0	1	0	0	ON
16*	0	0	0	0	0	0	0	0	0	ON

1= high output

0= low output

*= impossible in practice

Tests were conducted at 0, 5, 10, 15, 20, 25 and 30 degrees of tilt while the rotating table was rotated to get heading angles from 0 to 180 degrees for each tilting frame slope angle. Using this tilting table, the test for heading angles from 180 to 360 degrees also was done by turning the tractor position where the front wheels were placed opposite to the above setting. The four channel signal output from the weigh-pads and the four channel signal output from the transducers were recorded simultaneously using a 14-channel data recorder. Data recording was done continuously for a half circle rotation at each five degree of tilt.

Testing of Stability Alarm System in the Field

After testing in the laboratory, the tractor stability alarm was tested in the field. Due to the limitation of the field, the tractor was tested at 10 and 20 degrees of ground slope angle

(β) with heading angles (α) in 0, 30, 60 and 90 degrees. The tractor was operated in the steady state motion.



Figure 1: Testing in the laboratory on the tilting table for heading angle from 0 to 180 degrees

RESULTS AND DISCUSSION

Longitudinal and lateral Stability

The stability angles of the test tractor were calculated and are summarized in Table 2. From this table, it can be seen that the longitudinal (β_{long}) and lateral (β_{lat}) stability angles of the tractor without the operator are larger than that with the operator. The additional operator significantly increased the height of the center of gravity (L_{cg}). It slightly increased the distance of the center of gravity measured from the rear axle (L_{cg}). This situation decreased the angle of stability of the tractor. An additional load added below the center of gravity would increase the angle of stability. This can be done simply by adding the front end ballast.

Table 2: Results of center of gravity location determination and stability angles

	Lcg (cm)*	Hcg (cm)	β_{long} (deg.)	β_{lat} (deg.)
Without operator	54	43	52	41
With operator	55	63	41	31

* Measured from rear axle axis

Stability Transducers

The output characteristics of each stability transducers was different due to the manual construction of the transducers and the shape and size of each pair of transducers. This resulted in different conversion factors for the same equivalent load. Results of the reference voltage calculation for the chosen minimum safe angles are recorded (Table 3). From this table, the value in the lateral direction was chosen because this value will cover all other reference settings. This choice has a consequence that the minimum slope in the longitudinal direction is smaller than the setting angle.

Table 3: Results of reference voltage calculation

Direction		Transducer output (mV)			
		Front wheel		Rear wheel	
		Right	Left	Right	Left
Lateral		30	50	50	100
Longitudinal	Ascending	20	40		
	Descending			30	50

Alarm System Circuit

A simulated test voltage was fed into the alarm system circuit to test its working. In Fig. 2, the reference voltage for the right front wheel (Ref. R) was set at 30 mV and for left front wheel (Ref. L) was set at 50 mV. The condition of front wheel was simulated first by decreasing the input voltage from left front wheel channel (Left Whl.). When this input voltage crossed the reference voltage (Ref. L), the output of its comparator changed from positive saturation voltage to zero. This zero voltage condition continued as long as the input voltage was the same or smaller than the reference voltage. The output from OR-gate was still high, because the input voltage from right front wheel channel (Right Whl.) still produced positive saturation voltage on its comparator. Furthermore the final output of second AND-gate (Circ. Out) still produced high logic. When the input voltage of the right front wheel channel was decreased and crossed the reference voltage, the voltage output of its comparator went down to zero. This zero condition combined with the zero condition on left wheel channel produced low logic in OR-gate, and also changed the output of second AND-gate to become low logic. This low condition meant that the alarm was ON. When the input voltage of right front wheel channel was increased and crossed the reference

voltage, its comparator produced positive saturation voltage and changed output of OR-gate to become high logic. This condition changed the second AND-gate output to become high logic. This meant that the alarm was OFF. The results for rear wheel were also simulated.

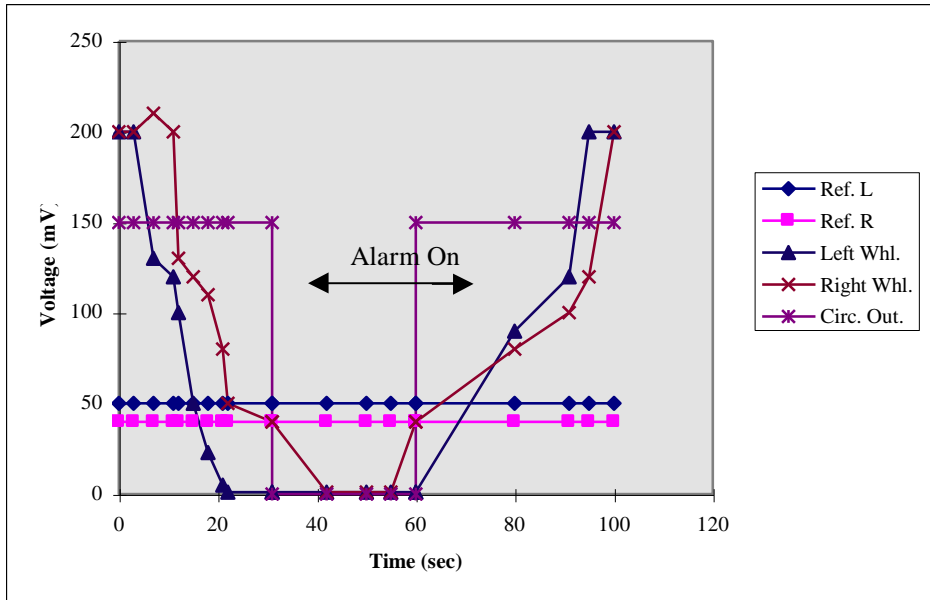

Figure 2: Simulation test of alarm circuit for front wheel transducers

Testing Stability Transducer in the Laboratory

The stability transducers were tested in the laboratory using tilting table. This testing provided comparison between the output of weigh-pad and stability transducers. When the angle of the tilting frame was increased, there were also different values of normal load between the left and right wheels. This was because of the change in weight distribution of the tractor. This difference is figured out by the value of difference output between the left and right wheels. The increasing value of the tilting angle also produced a wide range of minimum and maximum values of normal load as well as transducer output for each wheel.

The curve that has rather different shapes is the one for the curve resulting from the test when the tilting frame angle was 30 degrees. This difference occurred because the tractor slid on the incline. This gave the output signal not purely from the normal ground load, but with an influence from the force from wire rope tied to the wheel. This situation agreed with the prediction resulted from experiments conducted by Spencer (1978). He stated that the angle of control loss was smaller than the angle of stability loss, which caused the difficulty in conducting a stability experiment of the tractor using a real tractor.

From the above discussion, the stability transducer can be used to determine the change of wheel ground normal load in different slope angles and heading angles in the laboratory, either with the engine ON or OFF.

Testing of Stability Transducer in the Field

Fig. 3 shows the results of measurement for 10 degrees of ground slope. The results of these tests followed the trend obtained in the laboratory testing. Due to the small number of observation points and tractor vibration caused by engine as well as ground irregularities, the curves are not as smooth as the results in the laboratory. This vibration influence should be taken into account in determining the minimum slope angle when the reference voltage would be defined. The comparison between laboratory test results when the engine was OFF and the field test results, gave the maximum value of the difference voltage at 156 mV, and the minimum value at 188 mV.

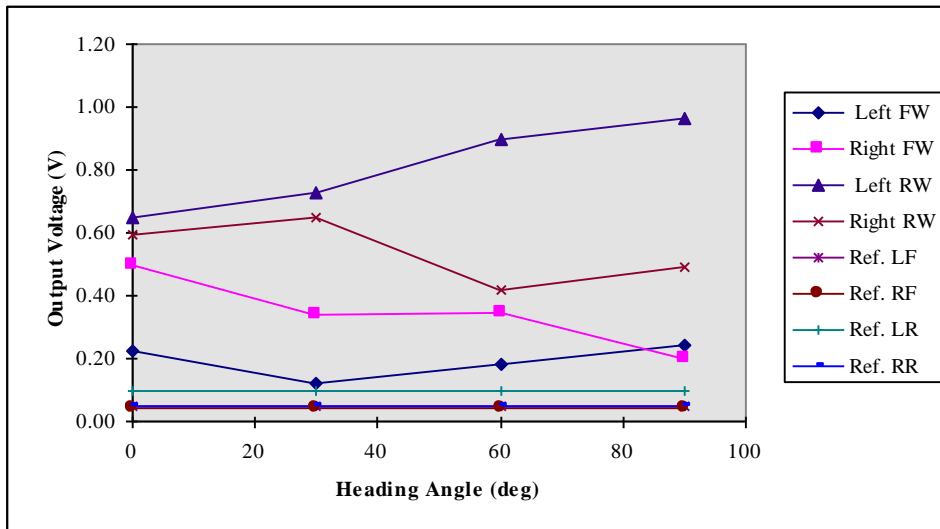

Figure 3: Testing of stability transducer in the field for 10 degrees of ground slope

Legend: Left FW = left front wheel transducer output; Ref. LF = left front wheel reference voltage; Right FW = right front wheel transducer output; Ref. RF = right front wheel reference voltage; Left RW = left rear wheel transducer output; Ref. LR = left rear wheel reference voltage; Right RW = right rear wheel transducer output; Ref. RR = right rear wheel reference voltage

CONCLUSIONS

The stability angle of the test tractor was found to be 41 degrees in the lateral direction and 52 degrees in the longitudinal direction. By additional operator weight, the position of

center of gravity and stability angle of this tractor changed. The developed tractor stability transducer unit, using strain gages as sensors, was found to work satisfactorily. The trend of the transducer output agreed with the changes in the normal load on the wheel when the heading angle as well as slope angle of the tractor was changed. Control loss occurred on the hard surface of weigh-pad before the stability angle was reached. This equipment may offer tractor manufacturers a new instrument and users an instability warning system for safety.

REFERENCES

1. HIDAYAT, I. (1996). Design and development of a four-wheel tractor stability alarm system for operator safety. M. Eng. Thesis No. AE-96-1, Asian Institute of Technology, Bangkok, Thailand (unpublished).
2. LILJEDAHN, J. B., Carleton, W. M., Turnquist, K. K. and D. W. Smith (1979). Tractors and Their Power Units. 3rd edition. John Wiley and Sons, Inc., New York.
3. SACK, H. W. (1956). Longitudinal stability of tractors. Agricultural Engineering, May, Vol. 37, p. 328-333.
4. SPENCER, H. B. (1978). Stability and control of two wheel drive tractors and machinery on sloping ground. Journal of Agricultural Engineering Research, 23(2):169-188.
5. SPENCER, H. B., OWEN, G. M. AND C. A. GLASBEY (1985). On-site measurement of the stability of agricultural machines. Journal of Agricultural Engineering Research, 31(1):81-91



VIBRACIJE PRENESENE S VOLANA TRAKTORA LPKT40 NA RUKE VOZAČA

VLADO GOGLIA*, ZLATKO GOSPODARIĆ

*Šumarski fakultet Sveučilišta u Zagrebu
Agronomski fakultet, Zagreb

SAŽETAK

U radu se iznose rezultati mjerenja razine vibracija koje se s upravljača traktora LPKT 40 prenose na ruke vozača. Za izabrane režime rada učinjena je frekvencijska analiza ubrzanja vibracija po srednjim frekvencijama terci. Izračunati su i vektori ekvivalentnih vrijednosti vrednovanih ubrzanja vibracija u sva tri smjera. Na osnovu njihovih vrijednosti određena je vrijednost rezultantnog vektora tzv. WAS – vrijednost (weighted acceleration sum). Tako dobivena WAS vrijednost unesena je u dijagram iz Annexa C međunarodne norme ISO 5349-1-2001(E). Na osnovu toga su procjenjene posljedice izloženosti vozača izmjerenoj razini vibracija.

Ključne riječi: traktor, vibracije prenesene na šaku-ruku, vrijeme izlaganja, posljedice po zdravlje

UVOD

Zaštiti rukovatelja mehaniziranim sredstvima rada se u razvijenim zemljama posvećuje sve veća pažnja. Sve su stroži kriteriji za ocjenu valjanosti pojedinog mehaniziranog sredstva sa stanovišta ergonomske značajki. Posebno mjesto pri tome zauzima odnos prema izloženosti buci i vibracijama. To se jasno može zaključiti na osnovu revidiranih vrijednosti u tzv. ergonomske check listama. Isto tako treba primjetiti da su značajni naponi uloženi u unapređenje postojećih međunarodnih normi kojima se propisuju postupci mjerenja vibracija. U posljednje su tri godine revidirane norme koje propisuju postupak mjerenja i procjene izloženosti vibracijama čitavog tijela kao i vibracija koje se prenose na ruku odnosno šaku rukovatelja. Postupak mjerenja i vrednovanja vibracija koje se prenose na čitavo tijelo propisan je normom ISO 2631-1-1997, a za one koje se prenose na sustav šaka-ruka normom ISO 5349-1-2001. Za vibracije koje se prenose na sustav šaka-ruka 1. 8. 2001. godine usvojena je posebna norma čija je zadaća da postupak mjerenja i vrednovanja

vibracija na radnome mjestu na praktičan način približi ovlaštenim mjeriteljima. Ista norma pod oznakom EN ISO 5349-2-2001 prihvaćena je od strane evropske normizacijske službe i postaje obvezujuća za sve članice EU od veljače 2002. Kako je poznato prethodna verzija iste norme iz 1986. godine je procjenu izloženosti vibracijama zasnivala na vrednovanim ubrzanjima u pojedinim osima. Nova norma procjenu izloženosti vibracijama zasniva na vektorskoj sumi vrednovanih ubrzanja u pojedinim osima. Na taj se način dopušteno izlaganje značajno smanjuje budući da je zadržan isti dijagram procjene opasnosti po zdravlje kakav je bio u starijoj verziji iste norme. Vektorska suma vrednovanih ubrzanja vibracija izračunava se prema relaciji (1):

$$a_{hv} = \sqrt{a_{hwx}^2 + a_{hwy}^2 + a_{hwz}^2}$$

gdje su:

a_{hwx} , a_{hwy} , a_{hwz} , - vrednovana ubrzanja u pojedinim osima

Druga značajna promjena je sadržana u procjeni dnevne izloženosti koja se zasniva na 8 satnoj vrijednosti energetskog ekvivalenta ubrzanja vibracija za razliku od stare norme koja je to isto zasnivala na referentnoj vrijednosti od 4 satnog dnevnog izlaganja. Da bi se pojednostavio postupak usporedbe dnevnih izlaganja različitog trajanja, treba dnevna izlaganja izraziti u 8 satnim ukupnim vrijednostima energetskih ekvivalenata vrednovanih ubrzanja vibracija prema relaciji (2):

$$A(8) = a_{hv} \cdot \sqrt{\frac{T}{T_0}}$$

gdje je:

T – ukupno dnevno trajanje izloženosti vibracijama a_{hv}

T_0 – referentno trajanje 8 satnog izlaganja (28 800 s)

Konačno, razlika je i u korekcijskom koeficijentu pomoću kojeg se izračunava vrijednost vrednovanog ubrzanja. Kako je poznato vrednovano se ubrzanje izračunava prema donjoj relaciji (3):

$$a_{h,w} = \left[\sum_{j=1}^n (W_j \cdot a_{w,j})^2 \right]^{\frac{1}{2}}$$

gdje je:

$a_{w,j}$ – ubrzanje vibracija u j-toj terci,

W_j – koeficijent za vrednovanje j-te terce dat u tablici A.2, ISO 5349-1-2001 za sva tri smjera koordinatnoga sistema.

Razlika u vrijednostima korekcijskog koeficijenta je prikazana na sl.1.

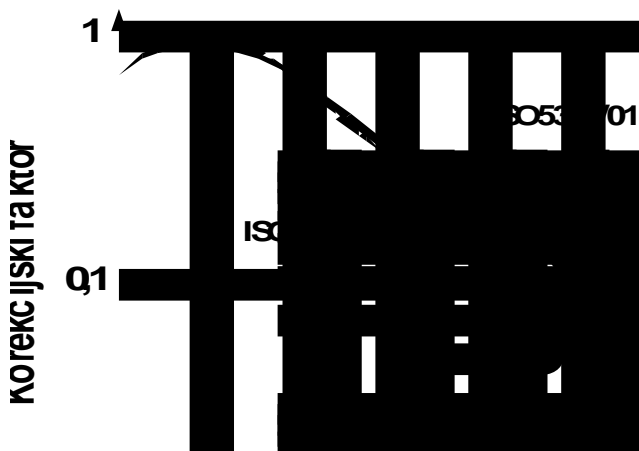

Slika 1. Korekcijski koeficijent za izračunavanje vrijednosti vrednovanih ubrzanja prema staroj i novoj verziji norme ISO 5349

Ako je posao takvoga karaktera da se sastoji od većeg broja aktivnosti različitih razina vibracija onda se dnevno izlaganje $A(8)$ treba izračunati prema relaciji (4):

$$A(8) = \sqrt{\frac{1}{T_0} \cdot \sum_{i=1}^n a_{hvi}^2 \cdot T_i}$$

gdje je:

- a_{hvi} – vektorska suma vrednovanih ubrzanja vibracija za i -tu operaciju
- n – broj pojedinačnih operacija različitih razina vibracija
- T_i – vrijeme trajanja i -te operacije

MJERENJA I REZULTATI

Mjerenja su obavljena na volanu traktora **LPKT 40**. Koordinatni sustav je bio postavljen sukladno preporukama međunarodne norme kako je to prikazano na sl.2.

Položaj akcelerometara na volanu je tijekom mjerenja bio sukladan s preporukama EN ISO 5349-2-2001 kako je to prikazano na sl 3.

Mjerenja su vršena istovremeno u sve tri koordinatne osi. Mjereno je u praznome hodu i kod približno nazivnog opterećenja. Za sva su mjerenja napravljene frekvencijske analize po srednjim frekvencijama terci. Za oba režima rada i za svaku koordinatnu os obavljeno je po pet mjerenja na osnovu kojih su izračunavane srednje vrijednosti ubrzanja vibracija po tercama. Rezultati su sadržani u tablici 1 te su grafički prikazani na sl. 4.

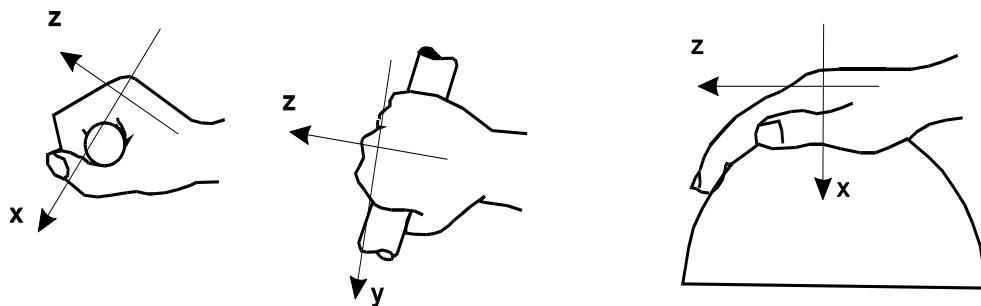

Slika 2. Položaj osi koordinatnoga sustava tijekom mjerenja

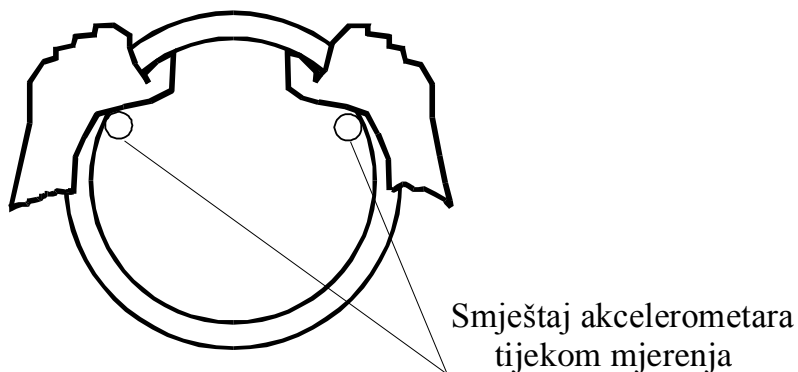

Slika 3. Položaj akcelerometra na volanu tijekom mjerenja

Tablica 1. Srednje vrijednosti razina ubrzanja vibracija po tercama, m/s^2

Os	Rezim	Frekvencija, Hz																
		6,3	8	10	12,5	16	20	25	31,5	40	50	63	80	100	125	160	200	250
x	PH	0,01	0,02	0,01	0,01	0,01	0,02	0,19	0,45	0,07	0,33	0,80	0,28	0,29	0,48	0,32	0,10	0,04
	Nomin.	0,01	0,01	0,00	0,01	0,01	0,06	0,01	0,04	0,19	0,04	0,24	1,60	0,27	0,17	0,14	0,11	0,09
y	PH	0,03	0,03	0,02	0,04	0,08	0,09	2,20	5,40	0,16	0,07	0,13	0,34	0,45	0,89	0,86	0,42	0,26
	Nomin.	0,03	0,03	0,06	0,06	0,11	0,53	0,08	0,13	0,34	0,21	1,20	8,20	1,20	0,81	1,50	0,92	0,79
z	PH	0,09	0,12	0,14	0,08	0,12	0,12	2,70	6,00	0,23	0,14	0,26	0,46	0,75	1,40	1,10	0,51	0,14
	Nomin.	0,04	0,06	0,09	0,06	0,09	0,52	0,08	0,14	0,62	0,35	2,10	14	1,90	1,10	1,80	0,97	0,65

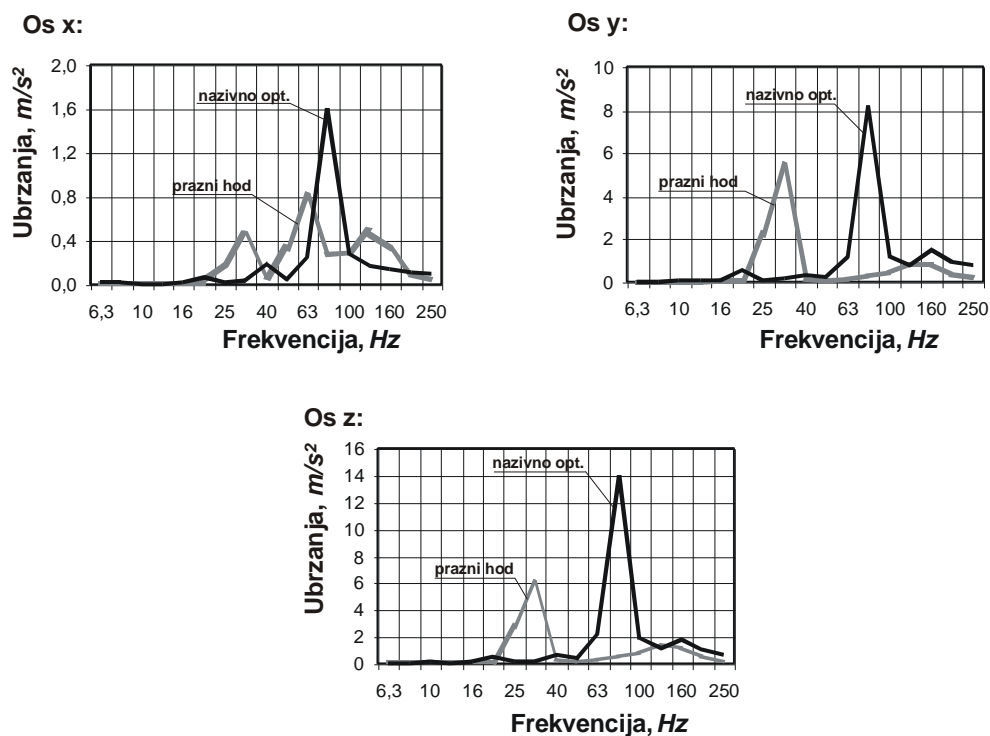

Slika 4. Grafički prikaz vrijednosti ubrzanja vibracija po tercama za sve tri osi kod oba režima rada

Na osnovu srednjih vrijednosti ubrzanja vibracija po tercama izračunate su vrijednosti vrednovanih ubrzanja vibracija za svaku os i za oba režima rada, a na osnovu tih vrijednosti izračunavani su rezultantni vektori vrednovanih ubrzanja vibracija (WAS vrijednosti – weighted acceleration sum). Rezultati su prikazani u tablici 2.

Tablica 2. Vrijednosti vrednovanih ubrzanja i WAS vrijednosti, m/s^2

Os	Režim rada	Vrednovana ubrzanja
x	PH	0.35
	Nominalno opt.	0.34
y	PH	3.04
	Nominalno opt.	1.76
z	PH	3.45
	Nominalno opt.	2.91
WAS	PH	4.61
	Nominalno opt.	3.42

Vrijednosti rezultantnih vektora vrednovanih ubrzanja su unešene u dijagram za predviđanje 10% vjerojatnosti pojave tzv. oboljenja bijelih prstiju. Dijagram je dat u Annexu C međunarodne norme ISO 5349-1-2001. Na sl. 5 dat je grafički prikaz rezultata mjerenja unešenih u spomenuti dijagram.

Uz pretpostavku da vozač tijekom radnoga dana u efektivnome radu provede 6 h odnosno 21 600 s, a u praznome hodu približno 1,5 h odnosno 5 400 s, energetski ekvivalent 8 satnog izlaganja pri nazivnom opterećenju bi prema relaciji (4) iznosio:

$$A(8) = \sqrt{\frac{1}{T_0} \cdot \sum_{i=1}^n a_{hvi}^2 \cdot T_i} = \sqrt{\frac{1}{28800} \cdot (3,42^2 \cdot 21600 + 4,61^2 \cdot 5400)} = 3,57 \text{ m/s}^2$$

Energetski ekvivalent je također unešen u dijagram na sl. 5.

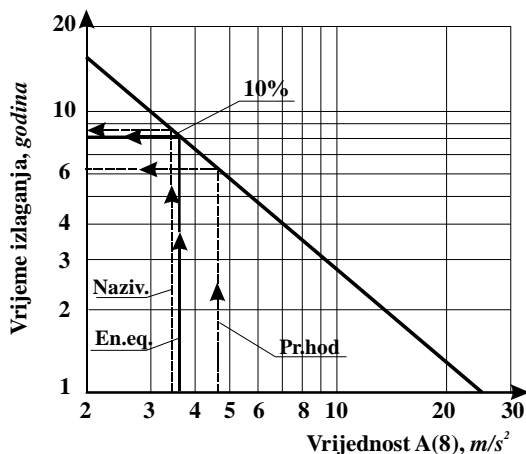

Slika 5. Dijagram za predviđanje 10% vjerojatnosti pojave oboljenja bijelih prstiju

Na osnovi provedenih mjerenja i analize može se predvidjeti da bi 10% vozača s pretpostavljenim trajanjem dnevnog izlaganja dobili bolest bijelih prstiju nakon 8 godina rada. Traktor na kojemu su mjerenja izvršena ima relativno dobro riješen sustav prigušenja mehaničkih vibracija koje se prenose na volan. Neusporedivo je lošije stanje na manjim traktorima i motokultivatorima te to zasigurno zaslužuje posebnu pozornost.

ZAKLJUČAK

Rezultati mjerenja iznijeti u ovome radu ukazuju na činjenicu da i ona mehanizirana sredstva rada koja izgledaju naoko bezopasna, sa stanovišta vibracija prenesenih na rukovatelja, mogu imati potpuno neočekivane efekte. Tako se traktor, na kojemu su

mjerenja obavljena, nalazi u redovitoj uporabi u JP Hrvatske šume već dugi niz godina. Zasigurno nije nitko očekivao da bi njegova upotreba mogla biti opasna po vozača. Treba upozoriti na to kako su mnoga mjerenja pokazala da su vibracije sa mjenjača traktora, sa ručki hidrauličkih razvodnika itd. potencijalni izvori vibracijskih bolesti. U Republici Hrvatskoj se tome posvećuje neodgovarajuća pažnja pa stoga nije čudno da vibracijske bolesti učestvuju sa 13% u ukupnom broju profesionalnih oboljenja. Također treba naglasiti da i u poljoprivredi postoje mnoga mehanizirana sredstva rada koja su potencijalni izvori takvih oboljenja. Stoga bi mjerenju vibracija, analizi i prevenciji trebalo posvetiti daleko veću pažnju od onoga što se danas čini.

LITERATURA

1. GOGLIA, V. et al. (2000) A research into the changes of ergonomic characteristics of some chain saws during their usually expected service life, IUFRO World Congress, Kuala Lumpur
2. GRIFFIN, M.J. (1996) Handbook of human vibration, Academic Press
3. REHSCHUH, D. et al. (1977) Checkliste fuer die ergonomische Beurteilung von Forstmaschinen, Mitteilungen des KWF Band XIX
4. HANSSON, J.E. (1990) An Ergonomic Checklist for Forestry Machinery, Skogsarbeten
5. (2001): ISO 5349-1- Mechanical vibration – Measurement and evaluation of human exposure to hand-transmitted vibration – Part 1: General requirements
6. (2001): EN ISO 5349-2- Mechanical vibration – Measurement and evaluation of human exposure to hand-transmitted vibration – Part 2: Practical guidance for measurement at the workplace

**TRACTOR LPKT 40 DRIVER'S EXPOSURE TO
HAND-TRANSMITTED VIBRATION
FROM THE STEERING WHEEL**

SUMMARY

The paper deals with measurement results of the vibration levels transmitted from the steering wheel of LPKT 40 tractor to the driver's hand. The vibration level on the steering wheel of tractor LPKT 40 were measured and analyzed. For chosen working conditions, the frequency spectra were obtained. The frequency-weighted acceleration, expressed in m/s^2 , were calculated. The vibration total values defined as the root-sum-of-squares of the three component values were calculated, too. The obtained values are in the paper graphically expressed in accordance with ISO5349-1-2001. The vibration exposure for predicting 10% prevalence of vibration-induced white finger in accordance with Annex C of the same standard was performed, too.

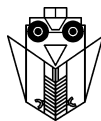

LAND USE PLANNING: A KEY TO SUSTAINABLE DEVELOPMENT

HUBERT N. VAN LIER, DANIELE DE WRACHIEN*

Department of Environmental Sciences
Wageningen University and Research Centre, The Netherlands,

*Institute of Hydraulics Agricultural
State University of Milan, Italy

SUMMARY

Sustainable use of the soil is a form of land management which retains the natural fertility of the soil and allows the production of food and fibre supplies and renewable natural resources on a long-term basis. It implies that the natural environment should be treated and managed in such a way that the cycles and energy flows among the soil, bodies of water and atmosphere are preserved or restored. To this respect, the term "sustainable land use" is more comprehensive than the term "sustainable soil use". The term "land" commonly, stands for a section of the earth's surface with all the physical, chemical and biological features that influence the use of the resource. It refers to soil, spatial variability of landscape, climate, hydrology, vegetation and fauna, and also includes improvements in land management, such as drainage schemes, terraces and other agrobiological and mechanical measures. The term "land use" encompasses not only land use for agricultural and forestry purposes, but also for settlements, industrial sites, roads and other human activities. Land use, in this meaning, can be termed sustainable only if it achieves such a spatial distribution or configuration of the different uses as to guarantee biodiversity and preserve the eco-balance of the whole system. Rational land use planning is fundamental to this process. With reference to these issues, this paper describes the main physical, social and economic features of land use planning projects, along with their environmental impacts and the constraints to sustainable development. The importance and role of institutional strengthening, sound financial and managerial frameworks, and the availability of human resources are analyzed, along with research thrust, technology transfer and networking improvement.

Key words: *Land use planning, sustainable development, networking system.*

INTRODUCTION

The world's population is expected to grow from 6 billion today to at least 8 billion in the year 2025. It is, therefore, clear that achieving food security and improving the quality of life, while preserving the environment, will continue to pose major challenges to scientists, decision-makers and technicians in the years to come. The main activity of agriculture is the production of food, so increasing agricultural development in a sustainable manner will be crucial in responding to these challenges.

In the past, growth in demand for food has been met by expanding agricultural land. Nowadays, the availability of new land is limited. Moreover, the more or less uncontrolled growth in agricultural production during the past few decades in industrial as well as developing countries, has pushed agricultural production to and, in many cases, over the edge of sustainability. This means that the traditional ways to increase production are facing a new challenge: how to find a new balance between agricultural development and the conservation of the natural resources.

Agricultural engineering has been applying scientific principles for the optimal use and management of natural resources for centuries, and its role is increasing in the new millennium. There are at least two reasons for this growing significance. First, it is well understood that the wise use of land resources will play a role of paramount importance in the provision of food for future generations. Second, the demand for different land uses is increasing tremendously, especially in the developed world. The land demands for cropping, grazing, forestry, wildlife, infrastructure, outdoor recreation, landscape as well as industrial and urban development are greater than the land resources available. Rational land use planning is an important tool to find a balance among these different demands and assure agricultural production, while conserving the natural environment.

This paper describes firstly the main physical, social and economic features of the land use planning process, along with its environmental impacts and the constraints to sustainable agricultural development. Later, the importance and role of institutional strengthening, sound financial and managerial frameworks, availability of human resources, research thrust, technology transfer and networking improvement are analyzed.

THE CONCEPT OF SUSTAINABLE LAND USE

To meet future challenges of food security, further development of agriculture is necessary. This development has to guarantee both the growth in agricultural output and the conservation of natural resources. The conservation of the natural resources is important because of the dependence of agriculture on these resources. This means that the natural environment should be treated and managed in such a way that food production is secured now and in the future. So, food security is not only a matter of quantity, but also of continuity. Agriculture is thus forced to find a balance between development and conservation. In this process the responsible use of natural resources plays a role of paramount importance. Among the basic natural resources, upon which life depends, is the soil.

The responsible use of the soil can be described in terms of sustainability or sustainable development. Sustainability has been defined in many different ways and there is no single, universally accepted definition. According to the Brundtland Commission “sustainable development is a process of change in which the exploitation of resources, the direction of investments, the orientation of technological development and institutional changes are all in harmony and enhance both current and future potential, to meet human needs and aspiration”. This process implies long-term perspective for planning and integrated policies for implementation. FAO has formulated its own definition of sustainability, specifically in the context of agriculture, forestry and fisheries: “sustainable development is the management and conservation of the natural resource base and the orientation of technological and institutional change in such a manner as to ensure the attainment and continued satisfaction of human needs for the present and future generations. Such sustainable development conserves land, water, plant and animal genetic resources, is environmentally non-degrading, technically appropriate, economically viable and socially acceptable”.

Scarcity of suitable soil is a major constraint for further agricultural development in many countries of the world. Therefore, as the demand for soil continues to increase, it is imperative that this limited resource be used efficiently for agricultural and other uses.

Sustainable use of the soil is a form of land management which retains the natural fertility of the soil and allows for the production of high quality of foodstuffs and renewable natural resources on a long-term basis. This means that the natural environment should be treated and managed in such a way, as to preserve or restore the cycles and energy flows among soil, bodies of water and atmosphere.

The phrase “sustainable land use” is more comprehensive than “sustainable soil use”. The term “land” is used to describe a section of the earth’s surface, with all the physical, chemical and biological features that influence the use of the resource. It refers to soil, spatial variability of landscape, climate, hydrology, vegetation and fauna, and also includes improvements in land management, such as drainage schemes, terraces and other agrobiological and mechanical measures. The term “land use” encompasses not only land use for agricultural and forestry purposes, but also for settlements, industrial sites, roads and so on. Land use, in this sense, can be termed sustainable if, and only if, it achieves such a spatial distribution or configuration of the different uses as to guarantee biodiversity and preserve the eco-balance of the whole system. In other words, land use that limits the interactions among soil, water and atmosphere and degrades the habitat standards vital to biological diversity of flora and fauna cannot be defined sustainable. In this respect, the term “sustainable land use” combines technology, policies and activities aimed at integrating socio-economic principles with environmental concerns. The term bears more dimensions or meanings:

- Sustainable use in the meaning of husbandry. In this meaning it is related to concepts such as continuity, durability and equity in the exploitation of natural resources over long periods of time. Husbandry refers to methods by which land is managed – crop rotation procedures, tillage systems and so on – all striving to preserve or restore the quality and fertility of the soil. This meaning is strongly related to the long-term physical and economic sustainability.

- Sustainable use in terms of interdependence. This meaning is related to the spatial dimension of sustainability. It involves such aspects as fragmentation and relations among different land uses. Many land use planning studies are currently focusing on this facet of sustainability since there are still a great uncertainty and lack of knowledge.
- Sustainable use in terms of ethical obligations to future generations. This refers to the loss and depletion of natural resources in combination with the expected increase in population. Land is not a simple commodity that can be stored and replaced, destroyed and remade, or even recycled in the same way as manufactured goods. It is a complex biological system, built up over long periods of time. The land could have lost its suitability for cropping or other uses by means of natural or anthropogenic causes. To restore its capacity for beneficial use while protecting the environment, methods of reclamation have to be tailored to the specific need. In this field much needs to be done to ensure the future of mankind.

Any assessment of sustainability would be incomplete if it did not address all the dimensions previously described.

Clearly, there are conflicts among these goals. More equity may mean less efficiency. In the short term it may not be possible to meet the needs or demands of even the present generations, let alone the future ones, if these needs or demands are greater than that which the environment can afford. Furthermore, degrading the natural resources will reduce their capacity to meet future needs, whatever those needs will be. So, demand management and the prevention of degradation play a basic role in the process of sustainable use and development of land. Decision – makers have to consider and agree upon a trade-off among different goals and, if the ecosystem as a whole is to survive, the use of natural assets must be matched by the development of human or physical assets of equal or greater worth. In this regard, good and reliable information is essential, that is, information on the people's needs, land resources and on the economic, social and environmental consequences of alternative decisions. The task of the land-use planners is to ensure that decisions are made on the basis of consensus, to avoid disagreement on the ways and directions the natural resources should be exploited. Wise land use planning will help to reduce the trade-off costs and resolve conflicts by involving the community in the decision process.

LAND USE PLANNING: A TOOL TO ACHIEVE SUSTAINABILITY

Land use planning is the systematic assessment of land and water potential, alternatives for land use and economic and social conditions in order to select and adopt the best land use options. Its purpose is to select and put into practice those land uses that will best meet the needs of the people while safeguarding resources for the future. The driving force in planning should be the need for change, the need for improved management or the need for a quite different pattern of land use dictated by changing circumstances. In the process all kinds of land use are involved: agriculture, forestry, wildlife conservation, urban and industrial expansions, tourism and amenities. Planning also provides guidance in case of conflict among the competing use by indicating which areas are most valuable for any

particular land use. Land use planning can be viewed as an iterative and continuous process, whose aim is to make the best use of land resources by:

- assessing present and future needs and evaluating the land's availability to meet them;
- identifying and resolving conflicts among competing uses and needs;
- devising alternative options and choosing those that best fit identified targets;
- learning from experience.

At every stage, as better information is available, the process may have to be changed to take account of it.

Goals are important in the planning process. They define what is meant by the best use of the land and they have to be specified at the outset of every planning project. Goals, normally, are divided into objects and targets.

Objectives are the general aims within the planning process. They allow the judging of different solutions to a specific problem in planning, and lead to suitable propositions and projects for the use of the land. Targets, on the other hand, are the detailed aims of land use planning. They lead to the design of actual measures that have to be taken and carried out in an area to solve a particular problem.

The objectives and targets identify the best use of the land. If two different forms of land use are expected to produce exactly the same profit (economically and socially), the objectives will determine which of the two land uses should be implemented, while the targets will indicate which procedures should be followed.

The goals, as a whole, may be grouped under three main headings: efficiency, equity and acceptability and sustainability.

- Efficiency refers to the economic viability of the land use plan.

The plan should yield more than it costs. So one goal of planning development is to make efficient and productive use of the land. In general terms, for any particular land use, certain areas are better suited than others. Efficiency is achieved by matching different land uses with the areas that will yield the greatest benefit at the least cost. However, it is not always clear which land use is the most profitable; this depends on the point of view. The point of view of individuals, for instance, focuses on the greatest return on capital and labour invested or on the greatest benefit from the area available. Government's point of view is more complex: it may include improving the foreign exchange situation by producing for export or for import substitution.

- Equity and acceptability represent the social features of land use planning.

The plan must be accepted by the local population, otherwise the proposed changes will not take place. Equity refers to the levelling of the living standards of the residents. People living in the planning area are expected to gain from the land use plan, even if they do not own the land. Living standards may include levels of income, food security and housing. Planning to achieve these standards then involves the allocation of land for specific uses as well as the allocation of financial and other resources.

- Sustainability, as stated before, refers to a development in land use planning that meets the needs of the present while conserving resources for future generations.

This requires a combination of production and conservation: the production of the goods needed by the people now, combined with the conservation of the natural resources on which the production depends. So, for land use to be sustainable, it has to be planned for the community as a whole, because the conservation of soil, water and other land resources is often beyond the means of individual land users.

Other goals of the planning process could be:

- Livability and Amenity. After the land use plan is implemented, the area should still be a suitable place to live for the inhabitants, as well as should include provisions for rendering life pleasant.
- Flexibility. The plan should be flexible and leave options for using the land in different ways if needed in the future;
- Public involvement. Every group or individual with an interest in the plan should be allowed to participate in the process, to keep their land use from disappearing through the plan, or to be offered a new land use, as part of the plan.

To be sustainable land use planning, should develop into an interdisciplinary, holistic approach that gives attention to all functions of the land and actively involves all land users through a participatory process of negotiation platform at national or local levels. The aim of the process is to create the conditions to achieve an environmentally sound, socially desirable and economically appropriate form of land use.

RESEARCH AND DEVELOPMENT

These days, international and national research needs to be focused more effectively than in the past on problems of land use planning and management. This is the only way to provide land users and planners with suitable and tested technologies for targeted measures to increase agricultural production while protecting natural resources. Poor efficiency of land usage, increasing environmental degradation, high costs and an absence of beneficial results are often seen as the result of a lack of research or the absence of application of research findings, or restricted access to new and advanced technology.

Successful research thrust on sustainable land use planning should include the following actions:

- Data base improvement;
- Adaptive research;
- Institutional strengthening;
- Socio-economic analysis;
- Environmental protection and conservation;
- Technology transfer and infrastructure.

Data base improvement

Availability of reliable hydro-climatic and other associated natural resource data is an essential prerequisite for sustainable land use planning development. As long as adequate and reliable data are not available, planning, design and management of land use programs will continue to remain guesswork, use of other natural resources haphazard and wasteful, and the development process unsustainable. Many land use projects were conceived and designed on a medium to long-term basis on the assumption that future climatic conditions will not be different from the past ones. This will not be so in the years to come, owing to the global warming and greenhouse effect. Therefore, land use planning designers and managers should begin a systematic re-examination of engineering design criteria, operating rules, contingency plans and land allocation policies. Demand management and adaptation are essential components for increasing project flexibility to meet uncertainties of climate change. On the whole, land use planning programmes can only be soundly formulated on the basis of adequate data on soil and its production capacity, potentially available water resources, performance of existing land use projects and other related factors.

Adaptive research

A wide variety of techniques or methods are used in land use planning. They are taken from the natural sciences (climatology, hydrology, soil science, ecology), from technology (agriculture, forestry, irrigation and drainage engineering) and from the social science (economics, sociology). Research for land use planning requires enhanced field investigations and a large variety of tools such as: Information Management, System Analysis, Decision Support Systems, Multicriteria Analysis, Geographic Information Systems, Remote Sensing, Computer Image Analysis, Sensors, Modeling Technique, Neural Network Technology, Land Evaluation. All these tools have to be considered under a broad and integrated approach related to food and other agricultural commodity production, rational land use planning, water saving, resource conservation, environmental impacts and socio-economic effects. Current research thrust needs to be reoriented by recognizing the complex role of the land resources in agricultural development, and by following a broad-based holistic approach. To this end, adaptive research programmes must be directed to investigate the actual and real problems associated with the planning, design, implementation and management of land use projects. It is important that the resulting methodology be technically feasible, environmentally and economically viable and socially acceptable.

Institutional strengthening

The importance of a functional and coherent institutional framework aiming to promote, at both national and international levels, the development of sustainable land use planning, has been fully recognized. The solution may not always require the creation of new and enlarged institutions and the establishment of larger governmental services. An important criterion in reorganizing and/or establishing new institutions should be the ability of such institutions to address successfully the multi-dimensional problems that are generally faced

by the land users at both local and national levels. Such institutions should be capable of undertaking, regulating, stimulating and facilitating the roles and the tasks carried out by the land users. These institutional frameworks need to be strengthened or restructured to meet more efficiently the land users' requirements and to promote the development of sustainable land use planning. International institutions should have effective linkages with all other national or local related frameworks, to optimize the use of physical, financial and human resources.

The necessary actions are the following:

- review, strengthen and restructure as required, existing institutions in order to enhance their capacity in land use planning activities;
- review, assess and revise if needed, existing legislation on land management within the broader framework of legislation for the development, use and conservation of land resources.

Human resource development

Successful technology and research thrust on land use planning depends on the number, orientation and quality of human resources (decision makers, professionals and research-related people) involved. They apply appropriate knowledge and skill to the solution of priority issues and emphasise the adaptation of available techniques to solve local problems. These knowledge and skill will include the ability to:

- identify local hurdles and constraints;
- formulate research strategies;
- design suitable technologies for testing, monitoring and evaluating;
- assess the technical, economic, social and institutional aspects regarding the application and adaptation of modern and advanced technology.

Moreover, this body of human resources will help national and international institutions, improve educational contents and training in land and other natural resources topics, and, in conjunction with scientific organizations, identify subjects to be further analyzed and investigated.

The necessary actions can be summarized as follows:

- assess training needs for land use planning and management;
- increase formal and informal training related activities
- develop practical training courses for improving the ability of extension services to disseminate technologies and strengthen land users' capabilities;
- enhance the capabilities of decision makers, administrators and officers at all levels, involved in land use planning programmes.

Social economic analysis

Social and economic analyses are important features of the land use planning process. A land use project, like many other projects, can be implemented only if the total benefits exceed the total costs. Therefore, sustainable land use planning should meet two basic considerations, namely economic viability and social acceptability. Comparisons of social with economic analysis can highlight the need for policy changes. A particular land use may be degrading and thus destroying other land resources. If the economic analysis shows the use to be advantageous from a land user's point of view, it is likely to continue whether the process is environmentally sound or not. Economic analysis should take account of damage to land resources and the consequent lowering of their productivity.

A great many land use planning projects in the past have failed due to the inadequate attention given to social and economic aspects in their design and implementation. Application of appropriate socio-economic analysis in all phases of the planning process is urgently required in the development of land use projects. In this regard it is recommended that:

- effort should be made to incorporate economic and social analyses in land use planning methodologies;
- governments, relevant international and national institutions and decision – makers should ensure that socio-economic analyses are adequately applied in the formulation and selection of land use planning projects for implementation.

Environmental protection

Sustainable land use planning has to find a balance between agricultural development and conservation of natural resources. Thus, development and environment are two aspects of the same process. Much agricultural land is deteriorating due to inappropriate soil and water management. Soil erosion, nutrient depletion, salinization and waterlogging all reduce productivity and jeopardize long-term sustainability. Wise management of the environment requires ability to forecast, monitor, measure and analyze environmental trends and assess the potentials of the land resources at different levels, ranging from the farm to the watershed. Adopting suitable environmental impact assessments will enable decision-makers, professionals and institutions to plan land use without irreversible environmental damage and allow sustainable natural resource use. Environmental impact assessments should be followed by monitoring and appropriate actions in order to maximize positive impacts of development and minimize environmental hazards. In this regard, environmental protection and conservation of natural resources must be made an integral part of development. It will be necessary to:

- carry out objective environmental impact assessments in order to ensure the sustainability and environmental acceptability of land use projects and programmes;
- establish environmental monitoring, evaluation and feedback systems on a long term basis;
- expand, improve and coordinate international assistance to improve the capabilities of less developed countries to assess, manage and protect their environment and natural resources.

Technology transfer and infrastructure

The success of a land use planning project is strongly influenced by the availability of technology and whether or not appropriate choices have been made to suit the local conditions. So, a framework for information transfer which includes storing, disseminating, receiving feedback and updating information is urgently needed to support sustainable land use activities. As in all economic activities, agricultural development, particularly involving the land use sector, has infrastructural requirements to ensure its success. Farmers and other land users must have appropriate funds, food supplies must be delivered on time and in adequate quantities, and proper marketing facilities and pricing structures must be assured. In addition to physical infrastructure, services such as education and health are also necessary. It will be necessary to:

- establish effective methods to facilitate the transfer of new and tested techniques and practices;
- encourage and provide facilities for the transfer of knowledge and experiences among developed and developing countries;
- enhance the development of a more effective production environment.

STRATEGIC ACTION PROGRAM

The above described themes and principles, strike at the root of the major problems encountered in the land use planning process. To be effective, they have to be translated into actions through the formulation of programs which have to take into account the actual conditions of the environment where they are expected to be implemented. These programs have to include:

- the adoption of a comprehensive approach that views land and water use and management and environment in an integrated manner;
- the promotion of regional cooperation to ensure that the concerns of all parties are factored into decisions;
- the recognition of the linkages among the different land uses;
- the encouragement of broad-based participation, including governments, professional and research institutions and non-government organizations;
- the endorsement of a phased program of action at the national and local levels.

This regional approach makes up and outlines the body of a Strategic Action Program, which is a critical measure for implementing priority actions at both national and local levels. The objectives of the Strategic Action Plan are to:

- evaluate trends;
- assess causes and implications;
- provide a cost estimate for investments;
- establish a framework for monitoring and evaluating;
- identify priority actions to address key issues.

Priority selection has to follow the criteria listed below:

- ensure selectivity, in order to concentrate resources on significant problems;
- avoid duplication and overlap;
- emphasize adaptive and cost effective solutions through adaptation and/or improvement of existing technology to specific tasks;
- select topics for investigation and research that are likely to realize the greater benefit, considering return on investment, response time, probability of success and impact on agricultural production.

This integrated approach is expected to bring forth clear benefits in environmental and economic terms, a more sustainable use of land resources in agriculture and higher yields and incomes.

CONCLUDING REMARKS

- Sustainable land use planning is a process that aims to integrate ecological with socio-economic, and political with ethical principles in the management of land, for productive and other functions, to achieve intra – and inter – generational equity.
- For formulating and implementing policies and strategies for land use planning it is essential to collect, process and disseminate timely and reliable information and utilize modern land assessment and evaluation technologies, to create sound scientific knowledge for proper decision support.
- The establishment of an effective networking system can greatly improve, enhance and speed up the process of collection, selection and exchange of information avoiding duplication and overlap.
- No detailed layout for sustainable land use planning can be drawn up for a region as a whole. A regional strategy can, at best, give a general idea of what needs to be achieved at the country level. Each country then will have to tailor its sustainable development strategy in view of its particular problems, constraints and comparative advantages.
- Regional strategies must set priorities and identify relevant projects, assess the environmental impacts of policies, investigate mechanisms to mobilize resources, enhance and encourage the participation of all concerned parties.
- The promotion and implementation of land use planning projects will not come free of cost. Major emphasis should therefore be paid on developing new sources of funds to supplement the national budget allocations. Chief among these approaches are measures that seek to mobilize local funds, in particular under the “user pays” principle.
- The challenging, but widely acceptable concept of sustainable land use planning calls for new approaches on development and therefore on land use and management. In this respect, new perspectives are required to manage the land and its associate resources. This is not only a question of allocating and controlling the use of the land, but of combining the knowledge of pressure influencing the resources themselves, with the relations among users and human and social objectives, the technologies available to

improve and enhance the land use planning process, the maintenance of biodiversity and natural equilibrium.

- The lessons learned demonstrate that it is necessary to make a decisive break from past policies to embrace a new holistic approach in land use planning and management, that is comprehensive, participatory and environmentally sustainable.
- There is an urgent need for adequately trained professionals who can work in the multisectorial environment of integrated natural resource management.
- Finally, to achieve a sustainable land use planning development, objectives and goals, policies and regulations should be based on local realities, traditions and natural resource management strategies. The environmental and socio-economic impacts of such policies and regulations should be assessed before they are implemented.

REFERENCES

The main purpose of this paper is to present the Authors' view on the role of Land Use Planning in sustainable development (primarily within the rural environment). Therefore, it was decided non to refer to the consulted literature in the text. The reference-list contains both used as well as other literature that provides important in-depth reading regarding the topic.

1. BEEK J.K., BURROUGH P.A. AND MC CORMACK E.D. (Eds) (1987) Quantitative land evaluation procedures. ITC Publication 6, Enschede, The Netherland.
2. BROUWER F.M., THOMAS A.J. AND CHADWICH M.J. (Eds) (1991) Land use changes in Europe. Processes of change, environmental transformations and future patterns. Kluwer Publisher, Dordrecht, The Netherlands.
3. BUNTING A.H. (1987) Agricultural environments. Characterization, classification and mapping. Wallingford, U.K.
4. CHISCI G. AND DE WRACHIEN D. (1999) Soil regeneration and improvement. In: CIGR Handbook of Agricultural Engineering, Vol 1, H.N. van Lier (Ed). St. Joseph, US
5. CLOKE P.J. (Ed) (1988) Rural land use planning in developed nations. Unwin Hyman Publisher. London, UK.
6. DAVIDSON D.A. (1980) Soil and land use planning. Longman Publisher. London, UK.
7. DE WRACHIEN D. (2001) Irrigation and drainage. Trends and challenges for the 21st Century. Proceedings of the 19th ICID Regional Conference on Sustainable Use of Land and Water. Brno and Prague, Czech Republic.
8. DE WRACHIEN D. (2001) Sustainable land use. The role of Agricultural Engineering. Proceedings of the International Conference on Sustainable Soil management for Environmental Protection. Soil Physical Aspects. Florence, Italy.
9. DE WRACHIEN D. AND CHISCI G. (1999) Soil reclamation. In: CIGR Handbook of Agricultural Engineering, Vol 1, N.H. van Lier (Ed). St. Joseph, US.

10. DONGEN M.W. AND VAN LIER H.N. (1999) Balancing agriculture between development and conservation. In: CIGR Handbook of Agricultural Engineering, Vol. 1, N.H. van Lier (Ed). St. Joseph, US.
11. ERVIN D., BATIE S. AND LIVINGSTON M. (1995) Developing indicators for environmental sustainability. The nuts and bolts. Proceedings of the Resource Policy Consortium Symposium. Washington D.C., US.
12. FAO (1990) An international action program on water and sustainable agricultural development. Rome, Italy.
13. FAO (1991) Guidelines on land evaluation for extensive grazing. FAO Soils Bulletin n. 58. Rome, Italy.
14. FAO (1991) Land use planning applications. Proceedings of the FAO Expert Consultation. Rome, Italy.
15. FAO (1993) Guidelines for land use planning. Rome, Italy.
16. FAO (1995) Planning for a sustainable use of land resources. Towards a new approach. Rome, Italy.
17. FLEISCHHAUER E. AND EFER H. (1998) Can sustainable land use be achieved? An introductory view on scientific and political issues. In: Towards Sustainable Land Use, Blume H.P., Eger H., Fleischhauer, Hebel H., Reij C. and Steiner K.G. (Eds). Reiskirchen, Germany.
18. FLEISCHHAUER H.E., HEBEL A. AND SOMBROEK W.G. (1998) Conclusion and Recommendations. In: Towards Sustainable Land Use, Blume H.P., Eger H., Fleischhauer, Hebel H., Reij C. and Steiner K.G. (Eds). Reiskirchen, Germany.
19. FORMAN R.T.T. AND GODRON M. (1986) Landscape ecology. Wiley Publisher. New York, US.
20. FRESCO L.O., HUIZING H.G.Y., VAN KEULEN H., LUNING H.A. AND SCHIPPER R.A. (1992) Land evaluation and farming systems analysis for land use planning. FAO/ITC. Wageningen, The Netherlands.
21. HAMDY A. AND DE WRACHIEN D. (1999) New policies and strategies on land and water development in the mediterranean region. Proceeding of the 2nd International Conference on Environment Water. Lausanne, Switzerland.
22. HERDT R. W. AND STEINER R.A. (1995) Agricultural sustainability. Concepts and conundrums. In: Agricultural Sustainability. Economic, Environmental and Statistical Consideration, Barnett V., Payne R., and Steiner R. (Eds). Chichester, UK.
23. HES M.B.A. AND VAN LIER H.N. (1999) Land and water use planning. In: CIGR Handbook of Agricultural Engineering, Vol 1, N.H. van Lier (Ed). St. Joseph, US.
24. JAARSMA C.F. (New approaches for planning of rural road networks within the frame of sustainable land use planning. Proceedings of the 2nd Workshop on Sustainable Land Use Planning with Special Regard to Central and Easter European Countries. Godollo, Hungary.
25. JAARSMA C.F. (1999) Planning of rural road networks. In: CIGR Handbook of Agricultural Engineering, Vol 1, N.H. van Lier (Ed). St. Joseph, US.
26. JURGENS C. (1992) Tools for the spatial analysis of land and for the planning of infrastructures in multiple land use situation. Proefschrift. Wageningen, The Netherlands.

27. KERKSTRA K. AND VRIJLANDT P. (1990) Landscape planning for industrial agriculture. A proposed framework for rural areas. *Landscape and Urban Planning*, n. 18.
28. KNEIB W.D. (1996) A landscape development plan as a tool for sustainable ecological planning. *Proceedings of the 2nd Workshop on Sustainable Land Use Planning with Special Regard to Central and Eastern European Countries*. Godollo, Hungary.
29. LACONTE P. AND HAIMES Y.Y. (1985) *Water resources and land use planning. A system approach*. NATO Advanced Studies Institute Series. Nijhoff, The Netherland.
30. LIER H.N. VAN (1996) Sustainable rural systems. A challenge also for land use planners. *Proceedings of the 2nd Workshop on Sustainable Land Use Planning with Special Regard to Central and Eastern European Countries*. Godollo, Hungary.
31. LINDGREN D.T. (1985) *Land use planning and remote sensing. Principles and applications*. Longman Publisher. Harlow, UK.
32. LOOMIS R.S. AND CONNOR D.J. (1997) *Crop ecology. Productivity and management in agricultural systems*. Cambridge University Press Publisher. Cambridge, UK.
33. MOLLETT J.A. (1984) *Planning for agricultural development*. Croom Helm Publisher. London, UK.
34. NCR (1991) *Towards sustainability. A plan for collaborative research on agriculture and natural resource management*. National Research Council (Ed). Washington DC, US.
35. OECD (1997) *Environmental indicators for agriculture*. Paris, France.
36. RENNINGS K. AND WIGGERING H. (1997) Steps towards indicators for sustainable development. *Linking economic and ecological concepts. Ecological Economics*. Vol. 20.
37. SCARASCIA MUGNOZZA G.T., TINELLI A. AND BENEDETTI A. (1999) *Interdisciplinary studies for the management of a sensitive natural area. Proceedings of the International Workshop on Soil Vulnerability and Sensitivity*. Florence, Italy.
38. STIGIANI W.M., BROUWER F.M., MUNN R.E. SHAW R.W. AND ANTONOSKY M. (1989) *Future environments for Europe Some implications of alternative developments paths*. Executive Report 15, IIASA Publisher. Laxenburg, Austria.
39. UN (1992) *Report of the United Nations Conference on Environment and Development United Nations (Ed)*. New York, US.
40. WCED (1987) *Our common future*. Oxford University Press. London, UK.
41. World Bank and UNDP (1990) *Irrigation and drainage research*. World Bank (Ed). Washington D.C., US.
42. YOKOI Y. (2000) *Measuring the environmental impacts of agriculture. OECD Agri-environmental indicators. Soil related issues. Proceeding of the International Workshop on Soil Vulnerability and Sensibility*. Florence, Italy.
43. YOUNG A. (1986) *Land evaluation and diagnosis and design. Towards a reconciliation of procedures*. *Soil Survey and Land Evaluation*, n. 5.10

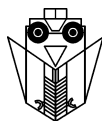

A MODELING AND ITS EXPERIMENTAL APPROACH FOR THE IMPEDANCE OF MULTI-PIN SOIL PROBES

YURUI SUN, MAOHUA WANG

Research Center for Precision Farming
China Agricultural University
Beijing China

SUMMARY

The multi-pin soil probe plays an important role in determination of soil water content with a variety of instruments, such as TDR (Time Domain Reflectometry), capacitance sensor and SWR (Standing Wave Ratio). Therefore, it is critical to calculate the impedance of the soil probe in order to improve the measurement accuracy of these instruments. However, the electromagnetic characteristics of the multi-pin probe is too complex to describe due to the hard-to-define boundary condition of Maxwell equation. Based on the theory of impedance transform of transmission line, a mathematical formula for the impedance of the soil probe was developed. By computing this formula, it was found that the impedance of the soil probe depends not only on the permittivity of soil-water-system, but also on the length of the probe-pin and frequency of its measuring signal. Especially, it is proved that the impedance and vice versa as measurement conditions change. In addition, it was confirmed that the formula for impedance of the soil probe had a series of periodical disconnected dots.

Key words: soil water, multi-pin soil probe, measurement accuracy, characteristic-impedance

INTRODUCTION

Since Topp et al. (1980) presented an equation to describe the relationship between soil moisture and permittivity of moist soil, the measurement methods based on dielectric properties of moist soil have become increasingly popular. These measurement technologies rely on the fact that the dielectric constant of water (ca. 80) is significantly greater than that of most soil matrix material (ca. 3) (Schmugge et al. 1980). The

measurement procedure of TDR is composed of two steps: (1) measuring propagation velocity of an electromagnetic pulse along a transmission line in soil and (2) converting this measurement into an estimate of soil water content through calibration. By using of TDR method one can get high accuracy results (ca. $\pm 0.5\%$) but the main problem for TDR instruments is their high cost. The TDR instrumentation needs a fast rise-time step pulse of about 100ps and light will travels a distance of 3.3cm in free space during such short time. This makes it difficult to design TDR-instrument and causes the relatively high price of the commercial products (Malichki and Skierucha 1989). Compared with TDR method, High-frequency capacitance sensor to determine soil moisture may give results with the same level of accuracy (Bell et al. 1987, Dean et al. 1987, Robinson and Dean 1993, Dean 1994, Paltineanu 1997, Gardner et al. 1998.) Unfortunately, it belongs to a kind of devastating methods for soil sample during measurement process. The geometric structure of the capacitance sensor is similar to a segment of coaxial line and actually these sensors are inappropriate for field use (Topp et al. 1980). A relatively new method, which stemmed from the principle of SWR (Standing Wave Ratio, was first reported by Gaskin and Miller (1996), Sun et al. (1999). Like TDR method, a measured value of SWR needs to be turned into an estimate of soil water content through calibration. One advantage of SWR sensor is its lower cost and another is that SWR method belongs to a kind of non-devastative method because of the probe with multi-pin structure. At present, the measurement accuracy of commercially available instruments based on SWR with $\pm 2\%$. Although measurement accuracy of SWR is slightly lower with it of TDR, the low cost would allow installation of SWR sensors in large quantities to monitor soil moisture at field scale. In fact, SWR as a valuable index depends on the change of the impedance of soil probe but how to calculate the impedance of soil probe with multi-pin structure was still a thorny problem due to its complex boundary conditions. As far as the measurement frequency is concerned, some investigations were performed (Hipp 1974, Hoekstra and Delaney 1974, Hallikainen et al. 1985, Campbell 1990). The presence of salts in soil water directly influences the dielectric behavior of soils, especially at frequencies $< 30\text{MHz}$ (Paltineanu and Starr 1997). This study attempted to establish a mathematical modeling for calculating impedance of multi-pin probe and some necessary experiments to check this modeling were conducted. At last, a prototype based on the modeling was designed.

THEORETICAL APPROACH

Figure 1 shows the field distributions of two-, three-, four-pin and an ideal coaxial cell given by Zegelin (1989). In particular, Zegelin pointed out that the field distributions of the three- and four-pin probes provide increasingly better approximations to an ideal coaxial cell in which the equipotentials are concentric circles centered on the inner conductor.

This fact means that although three and four-pin are classified as an irregular transmission line, their behaviors of the field distribution approximate to it of a coaxial line in some degree. The more pins a probe has, the closer to behavior of a coaxial line in the field distribution it is. Thus, an equation concerned with impedance transform of any regular transmission-line (Mcneil 1996), such as parallel-line and coaxial-line, can be employed.

$$Z_p(l) = Z_c \frac{Z_L + jZ_c \operatorname{tg} \beta l}{Z_c + jZ_L \operatorname{tg} \beta l} \quad (1)$$

where Z_p = transform-impedance of a segment of transmission line,
 Z_L = load-impedance of the transmission line,
 Z_o = characteristic-impedance of the transmission line,
 l = length of the transmission line
 β , called the phase coefficient of the transmission line, is defined as

$$\beta = 2\pi \frac{f}{c} \sqrt{\varepsilon} \quad (2)$$

where c = velocity of light traveling in free space (3×10^8 m/s)
 f = the frequency of the oscillator,
 ε = dielectric constant of the medium field in the transmission line.

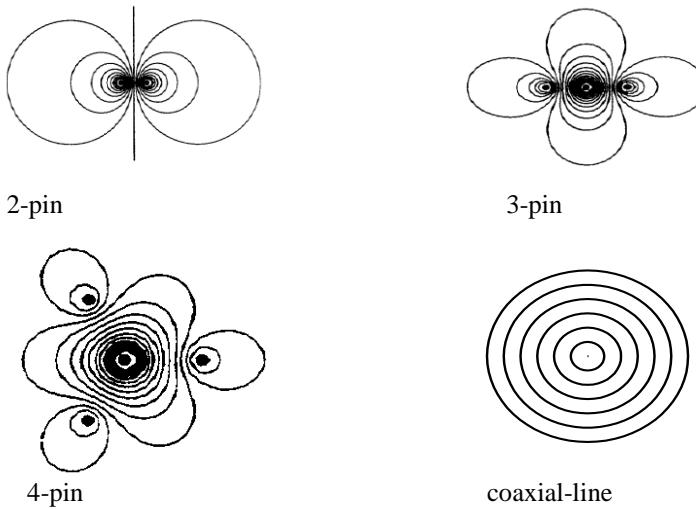

Figure 1. Dimensionless electric field distribution normal to the direction of probe insertion for a material of uniform dielectric constant

Under the assumption which multi-pin probe is equivalent to a segment of regular transmission line, Z_L should be considered as an open impedance for soil probe. Thus,

$$Z_p(l) \Big|_{Z_L=\infty} = Z_c \frac{Z_l + jZ_c \tan \beta l}{Z_c + jZ_l \tan \beta l} \Big|_{Z_L=\infty} = -jZ_c \operatorname{ctg} \frac{\omega\sqrt{\varepsilon} l}{c} \quad (3)$$

By some elementary transforms, the equation 3 can also be expressed as

$$Z_p(l) = Z_c \operatorname{coth} \left(\frac{2\pi\sqrt{\varepsilon} l}{c} j \right) \quad (4)$$

In order to calculate the impedance Z_p , the characteristic-impedance of probe should be solved in advance. It seems too difficult to calculate the impedance Z_p when the pins are more than two since Z_c is defined as

$$Z_c = \sqrt{\frac{L_d}{C_d}} \quad (5)$$

where L_d = the inductance distributed along a unit length of transmission line,

C_d = the capacitance distributed along a unit length of transmission line,

If the pins are more than two, the boundary conditions of the electromagnetic field around the probe pins will become much more complicated than them of two pins or coaxial line. Fortunately, an inequality was found to treat this thorny problem. It is known that the characteristic impedance of parallel line Z'_c can be calculated as

$$Z'_c = \frac{120}{\sqrt{\varepsilon}} \ln \frac{D_L}{d_L} \quad (6)$$

where $D_L/2$ = span of the outer and inner conductor,

d_L = diameter of the inner conductor.

Similarly, as for the characteristic impedance of coaxial line Z''_c , it can be computed by

$$Z''_c = \frac{60}{\sqrt{\varepsilon}} \ln \frac{D_C}{d_C} \quad (7)$$

where D_C = diameter of the coaxial line,

d_C = diameter of the inner conductor.

Choosing $D = D_L = D_C$ (figure 2), one can ensure

$$Z'_c \succ Z_c \succ Z''_c \quad (8)$$

and

$$Z''_c = 2Z'_c \quad (9)$$

Therefore, the characteristic-impedance of multi-pin can be safely estimated by

$$Z_c = \xi \frac{60}{\sqrt{\epsilon}} \ln \frac{D}{d} \quad (10)$$

where the dimensionless coefficient ξ should be fulfilled with

$$1 \geq \xi \geq 2 \quad (11)$$

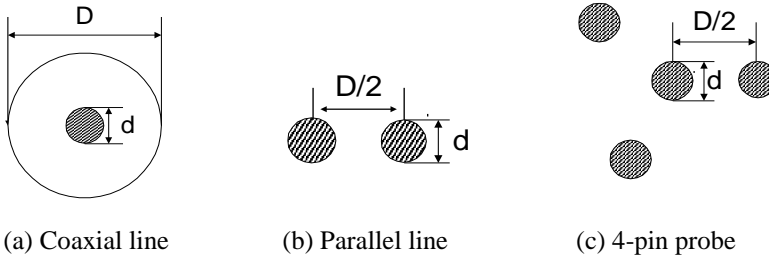

Figure 2. Geometric profiles of three types of the transmission line

Replacing Z_c in the equation 4 by the equation 10, finally one obtained

$$Z_p(l) = -j\xi \frac{60}{\sqrt{\epsilon}} \ln \frac{D}{d} \operatorname{ctg} \frac{2\pi fl\sqrt{\epsilon}}{c} \quad (12)$$

or

$$Z_p(l) = \xi \frac{60}{\sqrt{\epsilon}} \ln \frac{D}{d} \operatorname{coth} \frac{2\pi fl\sqrt{\epsilon}}{c} j \quad (13)$$

SOME ELECTROMAGNET PROPERTIES OF MULTI-PIN PROBE FROM COMPUTATION

The equation (12) or (13) shows that soil probe impedance changes not only depending on dielectric constant ϵ , but also on the l as well as the f when the geometric parameters D and d are invariable. Some computation results are presented in figure 3 under $l=10\text{cm}$, and in figure 4 under $f=100\text{MHz}$.

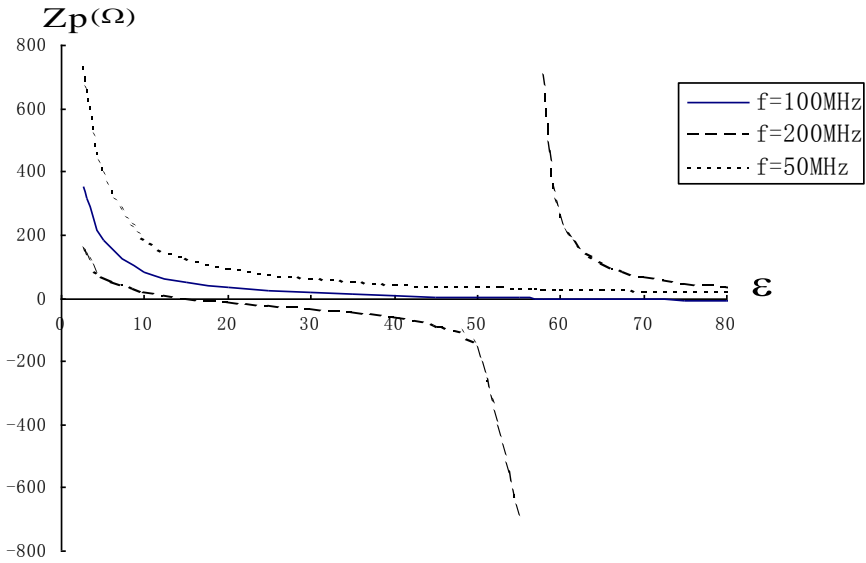

Figure 3. A cluster of curves between impedance of the probe soil and permittivity of moist soil referring to different frequencies, $L=10\text{cm}$.

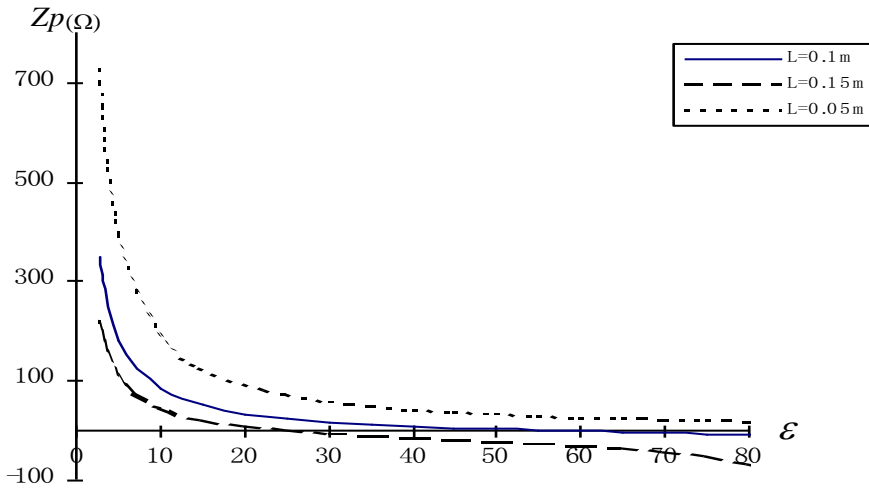

Figure 4. A cluster of curves between impedance of soil probe and permittivity of moist soil referring to different lengths of pin, $f=100\text{MHz}$.

From figure 3 and 4 some important electromagnetic properties of the probe can be drawn.

1. Above equation 12 or 13 is suitable for all types of soil probe with $1 \leq \xi \leq 2$. In case of $\xi=1$, the soil probe is just as a capacitance because its shape is similar to a segment of coaxial line. In case of $\xi=2$, the shape of soil probe is alike a segment of parallel line, i.e. a probe with 2-pin. When ξ is between 1 and 2, the pins of the soil probe will be more than two. Thus, all features generated by this computation have a broad sense for any type of soil probes.

2. In terms of multi-pin probe, ξ may be determined by calibration because of $\varepsilon \approx 1$ in air.

3. There exists a series of disconnected dots with periodical $n\pi$, $n = 1, 2, 3, \dots$. In order to avoid this unwanted case, a limitation should be added as below.

$$\frac{2\pi fl\sqrt{\varepsilon_{\max}}}{c} < \pi \Leftrightarrow fl\sqrt{\varepsilon_{\max}} < \frac{c}{2} \quad (14)$$

For example, from Topp equation, it is known $\varepsilon|_{\theta_v=50\%} \approx 32$, where θ_v is volumetric soil water content. choosing $f=100\text{MHz}$ and $c=30 \times 10^8 \text{m s}^{-1}$ in equation 14, the length of the pin should be less 0.26m.

4. Under the condition of

$$0 < \frac{2\pi fl\sqrt{\varepsilon}}{c} < \frac{\pi}{2} \Leftrightarrow 0 < fl\sqrt{\varepsilon} < \frac{c}{4} \quad (15)$$

the impedance of soil probe has the same properties as them of a capacitance. Similarly, if the condition satisfies

$$\frac{\pi}{2} < \frac{2\pi fl\sqrt{\varepsilon}}{c} < \pi \Leftrightarrow \frac{c}{4} < fl\sqrt{\varepsilon} < \frac{c}{2} \quad (16)$$

the impedance of soil probe has the same properties as them of an inductance.

EXPERIMENT AND DISCUSSION

The objective of the experiment was to check the equation 12 or 13. The used soil was clay-loam and its textural compositions were, sand 27%, clay 36% , silt 37%. Soil samples of clay-loam with different moisture contents ranging from 10.5% to about 42%. Over 40% moisture content used soil sample turned into saturated state so that homogenous status of the soil sample disappeared. The schematic diagram of the circuit to measure impedance of the soil probe is shown in figure 5. The tested probe had four pins whose profile was similar to it shown in figure 3c. The span of inner- and outer-pin was 2cm and the diameter of the pin was 0.35cm. All pins were made from copper.

In figure 5, DC means a detecting circuit. V_a or V_b stands for the output signal referring to input at each point a or b, respectively. An additional impedance Z_o was erected to offset the output impedance of the oscillator so that the value of Z_p depends only on Z_o , V_a and V_b in equation 17.

$$Z_p = \frac{Z_o}{V_a - V_b} V_b \tag{17}$$

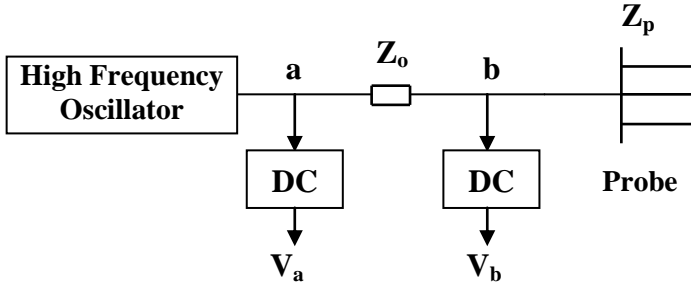

Figure 5. Schematic diagram of the circuit to measure the impedance of soil probe

Since the test aimed at checking the computation results shown in Figure 3 and 4, three different lengths of the pin were 5cm, 10cm and 15cm, respectively. The tested frequencies of the oscillator were chosen at 50MHz, 100MHz and 200MHz. The figure 6 shows the test results between the impedance of the soil probe and soil moisture referring to three different frequencies. This results confirmed that the impedance characteristics of the soil probe may be turned into an inductance from a capacitance and *vice versa* as test condition changed.

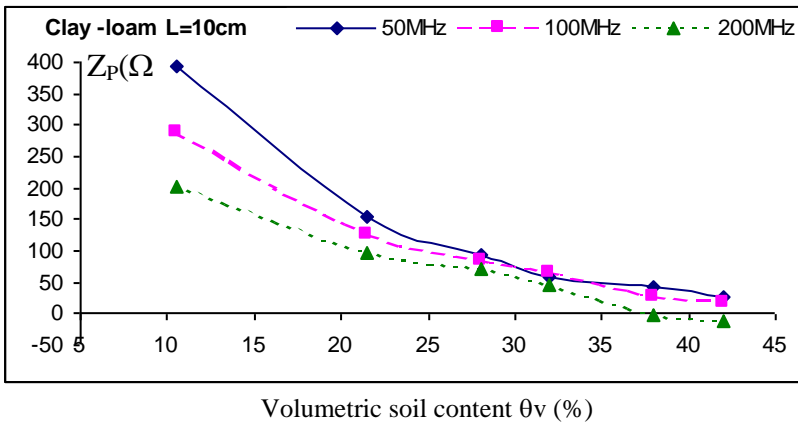

Figure 6. The measured relationship between impedance of the probe and volumetric water content referring to three different frequencies

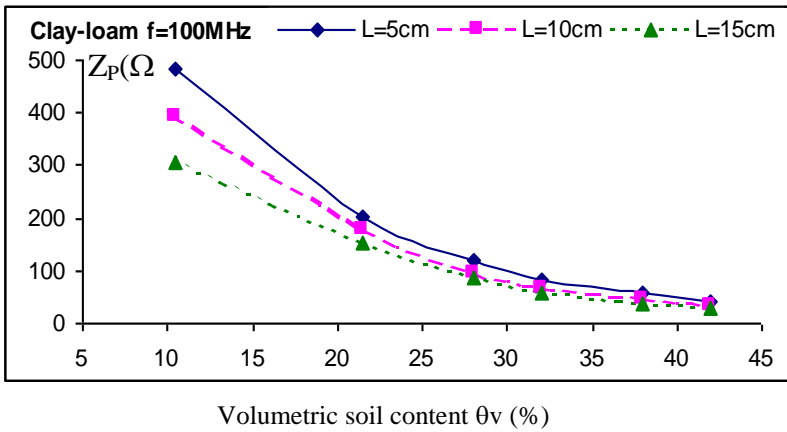

Figure 7. The measured relationship between impedance of the probes and volumetric water content referring to three different lengths of tested probes

Additionally, there exists an unwanted non-linear relationship between the impedance of soil probe and soil moisture. It should be corrected by instrument design. In order to check the relationship between dielectric constant ε and the impedance of the soil probe, Topp equation should be used

$$\varepsilon = 3.03 + 9.3\theta_v + 146\theta_v^2 - 76.7\theta_v^3 \quad (18)$$

Figure 8 shows a direct comparison between the equation 13 and tested results. The curve displayed in figure 8 came from the equation 13 and all spots from the measurement values.

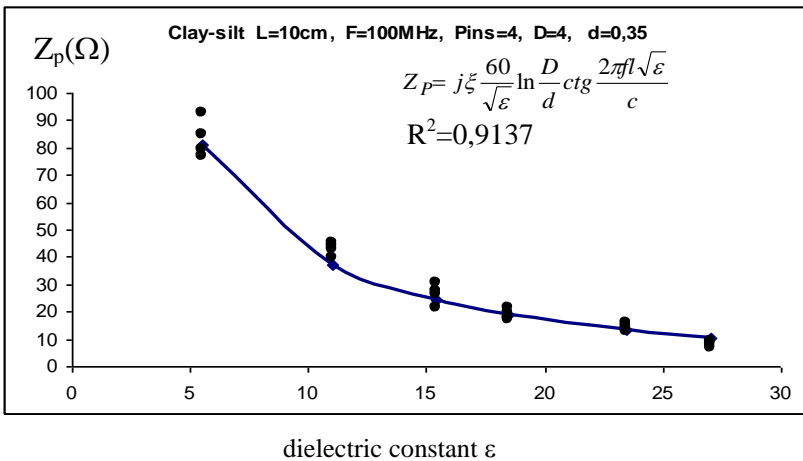

Figure 8. Comparison between the mathematical modeling and the test results

INSTRUMENT DESIGN

Based on above analysis, a prototype was developed (figure 9). The Volume of the prototype was $9.5 \times 15 \times 5 \text{ cm}^3$ and its power consumption was about 0.5W. The Schematic diagram of the prototype circuit (figure 10) was extended from it in figure 5 and two additional components Z_N , which consisted of a linearizer were parallel to inner- and outer-ends of the soil probe. The probe used in the prototype had three pins, the length of the pin was 6cm. Compared with TDR, the measurement error was limited to $\pm 3\%$ for most agricultural soils under the unsaturated case. Figure 11 shows that the linearization of the probe was considerably improved but the sensitivity of the soil probe was somewhat deteriorated after the linearizer was incorporated.



Figure 9. Prototype based on measurement of the impedance of the soil probe

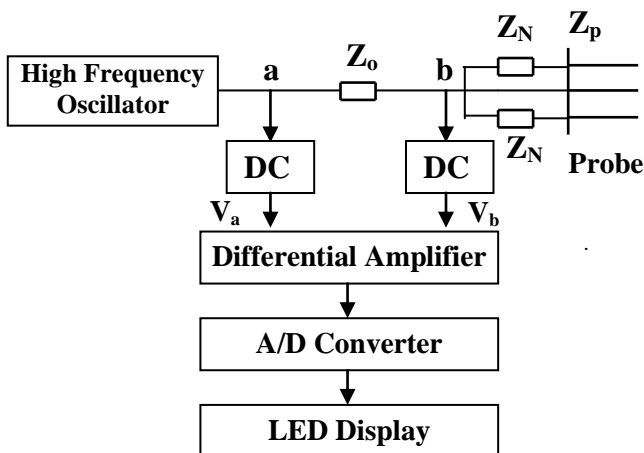

Figure 10. Schematic diagram of the prototype circuit to measure soil moisture

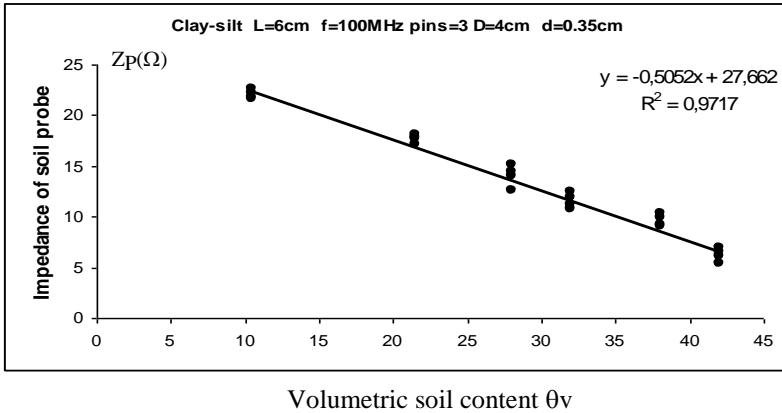

Figure 11. Linearization of the soil probe by parallel Z_N

CONCLUSION

The results of this study demonstrated that the impedance of multi-pin soil probe could be calculated by a modeling derived from the theory of the impedance-transform of transmission line. The trick to compute the characteristic-impedance of multi-pin probe was also discussed. By computation of the modeling, some important properties of the soil probe were discovered and the test results were favorite agreements with theoretical analysis. In addition, a new measurement method based on this modeling to determine soil moisture was presented and the prototype was designed. The modeling discussed in this paper has great potential to assess water content for grains and other porous media.

REFERENCE

1. BELL J. P., DEAN T. J., BATY A.J.B, (1987) Soil moisture measurement by an improved capacitance technique, Part II: field techniques, evaluation and calibration. Journal of Hydrology, 93, 79-90.
2. DEAN T. J., BELL J. P., BATY A. J. B., (1987) Soil moisture measurement by an improved capacitance technique, Part I: sensor design and performance. Journal of Hydrology, 93, 67-78.
3. DEAN T. J, (1994) The ICH Capacitance Probe for Measurement of soil water content, Institute of Hydrology Report Series, No. 125, Wallingford.
4. GARDNER, C. M. K., T.J. DEAN, J.D. COOPER, (1998) Soil Water Content Measurement with a High- Frequency capacitance Sensor, J.Agric. Res. 71 395-403.
5. GASKIN, G.J., J. D. MILLER, (1996) Measurement of soil water content using a simplified impedance measuring technique, J.Agric. Res. 63, 153-160.

6. HALLIKAINEN M. T., F. T. ULABY, M.C.DOBSON, M.A.EL-RAYES, AND L.-K. WU, (1985) Microwave dielectric behavior of wet soil, I. Empirical models and experimental observations, *IEEE, Trans. Geosci. Remote Sensor*, 23, 25-34.
7. HIPPI, J. E., (1974) Soil electromagnetic parameters as a function of frequency, soil density, and soil moisture, *Proc. IEEE*, 62, 98-103.
8. HOEKSTRA P., AND A. DELANCY, (1974) Dielectric properties of soils at UHF and microwave frequencies, *J. Geophys. Res.* 79, 1699-1708.
9. MALICKI, M. A., W. M. SKIERUCHA, (1989) A manually controlled TDR soil moisture meter operating with 300 ps rise-time needle pulse, *Irrig. Sci.* , 10, 153-163.
10. MCNEIL J.D., (1996) Lines and electromagnetic fields for engineers, New York Oxford, Oxford University Press, 132-136.
11. PALTINEANU, I. C., (1997) Real-time Soil water Dynamics Using Multi-sensor Capacitance Probes: Laboratory calibration, *Soil SCL. SOC. AM. J.*, VOL. 61. 1576-1584.
12. SCHMUGGE, T.J., T.J. JACKSON, H.L. MCKIM, (1980) Survey of Methods for Soil Moisture Determination, *Water Resour. Res.*, 16, 961-976.
13. SUN, Y., M. WANG, N. ZHANG, (1999) Measuring Soil Water Content Using the Principle of Standing-wave Ratio, ASAE presentation, paper no, 997063, Toronto, Canada.
14. TOPP, G. C., AND J. L. DAVIS, AND A. P. ANNAN, (1980) Electromagnetic Determination of Soil water Content: Measurements in Coaxial Transmission Lines, *Water Resour. Res.*, 16, 574-582.
15. ZEGELIN S. J., I. WHITE, AND D. R. JENKINS, (1989) Improved Field Probes for Soil Water Content and Electrical Conductivity Measurement Using Time Domain Reflectometry, *Water Resour. Res.*, 25, 2367-2376.

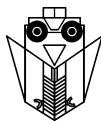

NAČINI OBRADJE TLA I SJETVA RATARSKIH KULTURA U SLAVONIJI I BARANJI

ROBERT ZIMMER¹, ZLATA MILAKOVIĆ¹, BLAŽ MILOŠ², ŽELJKO KRŽEK²,
MARTIN BRAČUN³, STJEPAN ZUZJAK³, JOSIP IPŠA⁴, MIRANDA ŠEPUT⁴

¹ Poljoprivredni fakultet Osijek; ² IPK Osijek «Ratarstvo-Stočarstvo»;
³ «HANA» d.d. Našice; ⁴ Belje d.d. Darda

UVOD

«Tlo nismo naslijedili od svojih djedova,
nego posudili od svojih unuka»

Ulaskom Republike Hrvatske 2001. godine u WTO i uključenjem Hrvatske poljoprivrede u globalizirano tržište prihvatili smo sva pravila poslovanja slobodnog svijeta. To znači, da smo spremni proizvoditi kvalitativne proizvode i uredno ih isporučivati poznatom kupcu po unaprijed dogovorenoj cijeni. Slavonija i Baranja imaju dobre uvjete da na svojim nezagađenim i ravnim površinama primjene najučinkovitiju tehniku i tehnologiju i proizvedu zdravu hranu s kojom se može ravnopravno nadmetati s ostalim naprednim zemljama na probirljivom svjetskom tržištu. Međutim, pitanje je gdje je naša ratarska proizvodnja sada i jesmo li sposobni za nekoliko godina od sadašnjeg uvoznika postati cijenjeni izvoznik hrane.

U posljednja tri desetljeća proteklog stoljeća u tehnologijama proizvodnje važnijih ratarskih kultura na velikim gospodarstvima u Slavoniji i Baranji gnojidba i zaštita bilja rješavala se skoro isključivo kemijskim putem. Zemljište je sve više siromašilo organskim tvarima i u njemu su se sve više nakupljale otrovne supstance. To je depresivno djelovalo kako na rast i razvoj biljaka, tako i na korisnu mikrofloru i faunu tla. Polako, ali konstantno se narušavao eko-sustav. Uslijed nedostatka stajnjaka plodnost tla se nadoknađivala povećanom uporabom sve skupljih mineralnih gnojiva što je još više pospješilo kvarenje njegove strukture.

Nedostatak šuma i šumaraka smanjio je životinjske asocijacije, posebno ptica čime se povećao negativni utjecaj biljnih bolesti, a naročito štetnika. Djelovanje vjetra i padalina u doba kada su s njiva skinuti usjevi izazvao je mikro i makro erozivne pojave što bitno

utječe na biljni pokrivač. Oko 40% obradivih tala sklono je mikro-makro eroziji. Monokultura narušava eko-sustav prirode, a ekonomski razvoj društva stvara sve pogubnije zagađivanje staništa. Priroda nema ni nagrade ni kazne – samo posljedice, pa prirodni raj svojom nesmotrenošću polako pretvaramo u pustoš.

Šume i šumarci su prirodni regulator podzemnih i površinskih voda, donatori kisika, umanjuju eroziju putem vode i vjetra, te reguliraju mikrofloru i faunu okoliša. Eko-sustavi su najugroženiji ljudskim djelovanjem. Danas se žele stvoriti novi biotopi što ide vrlo teško. Red se polagano uspostavlja, a brzo kvari. Samo trajan timski rad taj red može zadržati, nered smanjiti i ponovo red obnoviti.

Prije agrotehničkih mjera u agraru trebalo bi riješiti pitanje suviška nadzemnih i podzemnih voda, te izvršiti rajonizaciju proizvodnje svih važnijih poljoprivrednih kultura.

Nepovoljna klima i klimatski uvjeti nastoje se korigirati i ublažiti raznim agrotehničkim mjerama, a posebno integriranom tehnikom koja zahtjeva prethodno uređenje skoro svih sjetvenih površina u poljoprivredi (4). Prva mjera uređenja je grupiranje površina putem arondacije i komasacije. Na grupiranim površinama neophodna je izgradnja suvremene putne mreže jer na integrirani transport (unutarnji i vanjski) otpada 35% i više ukupnih radnih sati u poljoprivredi. U tu svrhu nužna je i izgradnja prihvatnih pista na određenim lokacijama koje služe kao prijemna skladišta posebno kabastih roba, a ujedno su i privremena organizirana radilišta.

Za pravovremenu kvalitetnu obradu, a time i sigurnu proizvodnju neophodni su hidro-melioracijski sustavi na većini tala koji će putem laserski postavljene drenaže odvoditi ili dovoditi potrebne količine vode u tlo.

S obzirom na vrlo mali postotak navodnjavanih površina kod nas (do 1%) tom segmentu treba se što hitnije pristupiti i riješiti ga.

Buduću pažnju posebno pridati higijeni polja i ekologiji eko-sustava gdje bi se proizvodila biološki zdrava hrana vodeći računa o «efektu susjeda» (12).

Za racionalnu proizvodnju nužno je i meliorativno ravnanje svih ratarskih površina (11). U određenim tipovima tala, gdje je potrebno miješanje i rahljenje oraničnog i podoraničnog sloja obavljati treba meliorativno rahljenje putem dubinskog aktivnog rahljača.

OPREMANJE GOSPODARSTAVA SREDSTVIMA MEHANIZACIJE

Razvijeni i u poljoprivredi uvedeni strojevi i uređaji u drugoj polovini dvadesetog stoljeća olakšali su rad i povećali učinkovitost poljoprivrednika više nego je to učinio ukupni prethodni razvoj tehnike. Sredinom šezdesetih tehničari i inženjeri postaju mehanizatori na svim kombinatima. Programiraju opremanje, traže tehnička rješenja za nove tehnologije i stručnu eksploataciju tehnike, školuju radnike prevodeći kočijaše u traktoriste. Mehanizacije se prihvaćaju agronomi skloni tehnici, sposobni za učenje i usvajanje inovacija. Unatoč tome moderniziranje proizvodnje sporo se odvijalo na velikim gospodarstvima Slavonije i Baranje.

Ozbiljnija opskrba traktorima započinje 1966. nakon usporednog ispitivanja traktora velikih snaga. Tada su to bili Schlüter 900 od 66 kW (90 KS), John Deere 4020 sa 76 kW

(104 KS) i drugi. Tek nakon toga su slijedile brojne političke aktivnosti, nakon kojih je kombinatima odobren uvoz ograničenog broja traktora. Bio je to najveći skok u produktivnosti, kakvoći obrade tla i uvođenju novih tehnologija. Istovremeno se odobrila i manjim obiteljskim gospodarstvima kupovina traktora snage motora do 29 kW (39 KS).

Od 1966. god. uvedeni su dobri berači – komušaći i berači – runjači New Idea. Uvodi se i žitni kombajn opremljen za berbu i runjenje kukuruza. Budući je takvu adaptaciju prvi napravio John Deere 1954. godine, na inovaciju nismo dugo ni čekali. Nakon 1966. god. i spomenutog ispitivanja traktora sve se u poljoprivredi Slavonije i Baranje brže mijenjalo. Nabavljeni su odlični plugovi, sjetvospremači i sijačica za preciznu sjetvu kukuruza u čemu je OLT Osijek odigrao pionirsku i važnu ulogu. Berbu kukuruza preuzeli su žitni kombajni Zmaj – Univerzal. Početkom proizvodnje kombajna «Đuro Đaković» (po licenci tvrtke Fahr) u Županji od 1982. god. tehnički su bile dobro riješene žetve strnih žitarica, kukuruza, uljarica, vršidba sjemenskih trava, sjemenske šećerne repe i dr.

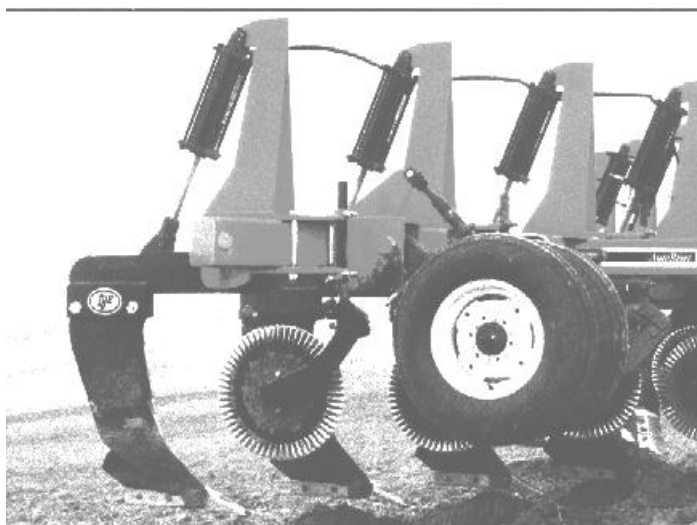

Slika 1. Dubinski aktivni rahljač

Danas posjedujemo odlične žitne univerzalne kombajne čija propusna moć doseže 20 kg/s (J.D. CTS 9780, Claas Lexion 480), a tu su i šestredni repni samokretni kombajn sa spremnikom 24 do 40 m³ (Holmer Terra Dos), opremljen kao i žitni s uređajem za mjerenje trenutnog prinosa i kartiranje plodnosti tla. Silažni kombajni (Claas Jaguar 860, John Deere) s egzaktnim rezom silažne mase na zadanu duljinu već od 4 mm među najuspješnijim su strojevima. Tržište danas nudi kao redovnu opremu (3) informatizirane i vrlo učinkovite integrirane strojeve za prskanje i gnojidbu, te za obradu i sjetvu u jednom proходу (Horsch Airseeder).

U postupku je opremanje traktorima snaga između 80 i 220 kW (110 do 300 KS). Visokog su učinka i treba ih sve manje, a to je jedan od preduvjeta racionalne poljoprivrede

(2). Radi toga gospodarstva se povećavaju, a broj im se smanjuje. Optimalna veličina gospodarstava se mora pomicati na više ili traži uvođenje intenzivnijih proizvodnji sa ciljem zaokruženja proizvodnje i dorade proizvoda. Radi toga zadaće struke postaju sve složenije, jer je krajnji cilj usavršavanje proizvodnje koja daje najveći profit i ima diferencijalnu prednost nad dosadašnjim proizvodnjama. Zbog toga, a i radi očuvanja plodnosti tla, polako ali sigurno uvodi se racionalna i konzervirajuća obrada poljoprivrednih površina. Koliko je ona zastupljena u Europi i kakve su prognoze vidljivo je iz sljedećeg grafikona.

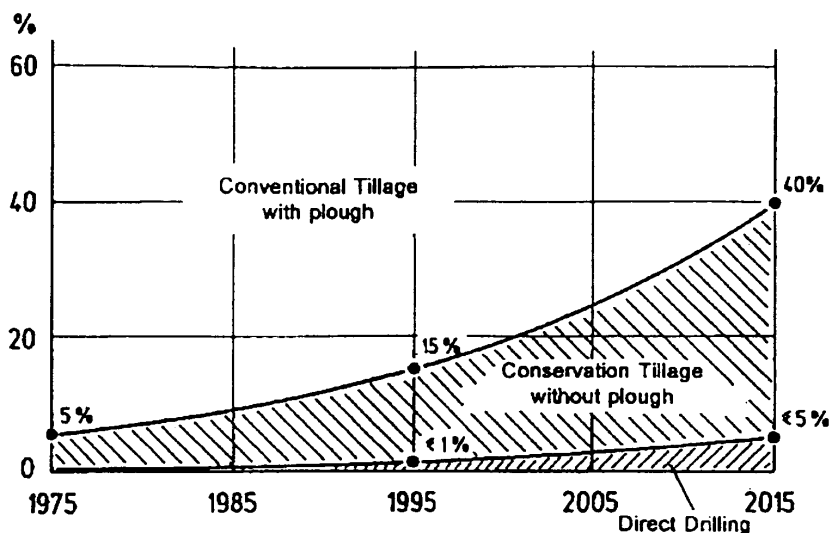

Grafikon 1. Tendencije budućeg razvoja načina obrade tla

Iz prikaza je vidljivo da je u Europi tendencija napuštanja skupe konvencionalne, te uvođenje znatno jeftinije racionalne obrade tla. Druge zemlje, a posebno SAD to su učinile daleko ranije i u znatno većem postotku, a to čine i danas. Kako se to kretalo u SAD vidljivo je po broju prodanih plugova koji su osnova konvencionalne obrade.

Lemešni plug nije potisnut s polja Slavonije i Baranje, posebno na malim obiteljski, kao i na mnogim većim gospodarstvima. Ulaskom u WTO gospodarstva će biti prisiljena na produkciju jeftinije hrane, a to znači na napuštanje konvencionalne obrade tla pri proizvodnji poljoprivrednih proizvoda.

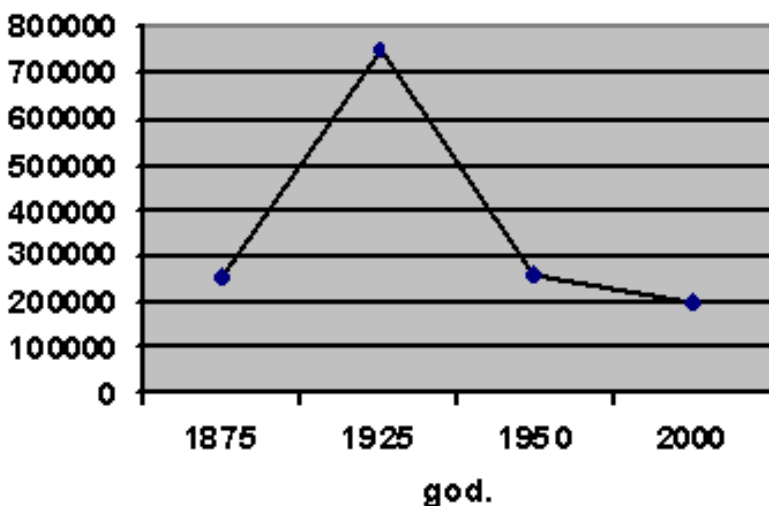

Grafikon 2. Broj prodanih plugova u SAD

NAČINI OBRADE TLA U SLAVONIJI I BARANJI

Prema Pelizzi i sur.(13) obrada tla sudjeluje s oko 40% u ukupnim troškovima, odnosno od ukupne energije potrebne za obavljanje poslova u polju oko 38% otpada na obradu tla. Znakovito je da od navedenih 38%, čak tri četvrtine troši primarna obrada, što jasno ukazuje na činjenicu da je obrada tla jedno od ključnih mjesta u agrotehnici gdje treba nastojati smanjiti utrošak energije.

Poljoprivrednicima su poznata tri temeljna načina obrade: konvencionalna, racionalna (konzervirajuća) i nulta obrada.

Konvencionalna obrada tla značajna je po tome što je prva operacija korištenje lemešnog pluga nakon kojega slijedi potreban broj (u prosjeku od 4 do 8) operacija dopunske obrade. Neosporno, to je najskuplji način obrade tla (5), koji je dominantan ne samo u Slavoniji i Baranji već i na 85% proizvodnih površina EU (14). Unutar ovog načina obrade moguće su određene modifikacije kojima se nastoji smanjiti utrošak energije, te ljudskog i strojnog rada. Modifikacije se odnose prije svega na povezivanje poslova sastavljanjem jednovalentnih strojeva u tzv. integrirani agregat, pa tada govorimo o reduciranoj obradi. U stručnoj literaturi reduciranu obradu karakterizira smanjenje dubine obrade ili smanjenje broja operacija (1). U SAD su još 1970. god. započeli s reduciranjem obrade tla uvođenjem rovila i para plugova, pa sve do danas kada se koriste različite kombinacije oruđa tipa Ecolo Tiger, Ripper i dr. U Europi poljoprivrednici nerado izostavljaju oranje i vrlo im je prihvatljiva predstajena obrada i sjetva u jednom proходу agregatom sastavljenim od zvrk drljače (cyclotiller/rototiller) i sijačice. Vrlo je prihvatljiv viši stupanj reduciranja koji u jednom proходу obavlja ukupnu obradu tla i sjetvu. Kod nas su već više od jedne decenije poznati integrirani agregati tipa RAU. Pri odabiru tehnike za obradu tla bitno je ne

zaboravit da se reduciranje obrade tla može izvoditi do mjere u kojoj se ono neće oštećivati, a ostati rahlo sa željenim odnosom krute (50%), tekuće (25%) i plinovite (25%) faze.

Racionalnu obradu karakterizira supstitucija lemešnog pluga rovilom (čizl-plugom ili gruberom), dakle primarna obrada bez okretanja oraničnog sloja tla (8, 9). U tom slučaju tlo se mora prethodno pripremiti i zatim održavati. Pod tim se podrazumijeva duboko rahljenje i razbijanje tabana pluga, ne ulaženje na oranicu nikakvim transportnim sredstvima i obavljanje žetve i berbe kombajnima po tlu normalne vlažnosti, opremljeni širokim, terra gumama ili gumenim gusjenicama.

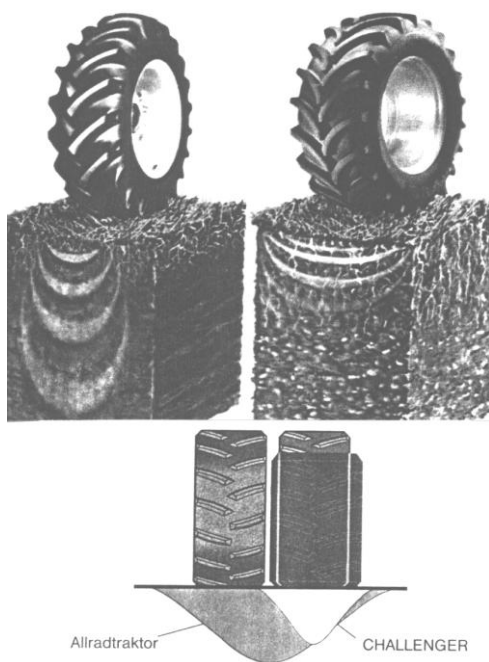

Slika 2. Usporedba specifičnog tlaka na podlogu često korištenih dimenzija stražnjih traktorskih guma izražena u g/cm^2 ($g=9,80665 \text{ N}$), te prikaz utjecaja tlaka na tlo traktora s pogonom na sve kotače i traktora s gumenim gusjenicama (PUP 4/2001.str.25)

Opis gume	Dimenzija	Relativni odnos površina nalijeganja A	Tlak g/cm^2
Radijalna	20,8 x 42	100 %	1.520
Radijalna niskotlačna	710/75 - 34	135 %	1.110
Radijalna udvojena	20,8 x 42	190 %	800
Terra guma	73 x 33,00 - 32	225 %	680
Čovjek mase 75 kg			400

Konzervirajuća obrada je prva operacija odmah nakon prolaska kombajna. Dakle, ako se doslovce odmah nakon prolaska kombajna opremljenog sa sitnilicom i uređajem za jednoličnu raspodjelu svih usitnjenih biljnih ostataka ne prođe agregatom kojim se obrađuje površinski sloj tla, miješaju biljni ostaci s tlom, te «zatvori» površina radi očuvanja vlage, nema konzervirajuće obrade (7). Može se obaviti multitillerom, rototillerom, gruberom, ali i Kombisemom RAU, odnosno Rotosemom RAU s rotorom i sijačicom radi istovremenog usijavanja međusjeva. U bliskoj budućnosti očekujemo uporabu nizozemskog tanjurastog pluga (Vario – Disk) kojemu se svaki disk podešava u svim smjerovima (6). Prema inozemnim iskustvima takvim se strojem može odlično obaviti konzervirajuća obrada («prašenje strništva») odmah nakon prolaska žitnog kombajna.



Slika 3. Multitiller RAU



Slika 4. Kombisem RAU

Izravnu sjetvu ili no-till sjetvu karakterizira izostavljanje obrade u klasičnom smislu. Sjetva se obavlja na tlu priređenom za takav sustav proizvodnje posebno izvedenim sijačicama, koje obrađuju zonu tla širine 3-5 cm stvarajući tako brazdicu u koju se ulaže sjeme. U našoj poljoprivredi već su zastupljene tipične no-till sijačice tvrtki John Deere 750 A zahvata 6 m, Great Plains zahvata 4,5 m i 6 m, Tye od 4 m, 4,5 m i 6 m, John Deere Max Emerge od 6, 8 i 12 redi i Amazone AD 453 zahvata 6 m.



Slika 5. John Deere Max Emerge 2



Slika 6. John Deere 750 A



Slika 7. Great plains no-till system 2015



Slika 8. Amazone AD

U Slavoniji i Baranji polako ali sigurno se napušta konvencionalna, a prihvaća reducirana i racionalna obrada tla. Nulta obrada je manje zastupljena radi klimatskih i drugih još neispitanih faktora. Racionalna obrada sve više ulazi u ratarska gospodarstva radi ekonomskih razloga, a i zbog očuvanja strukture tla. Problem je u tome što je to multidisciplinarni projekt (15), za koji je najbitnija promjena shvaćanja u glavama stručnjaka i izvođača operacija zbog čega ovaj projekt se negdje više, a negdje manje primjenjuje. Za izvođenje ovakvog načina obrade tla i sjetve neophodna je odgovarajuća tehnika, koja neminovno uvjetuje tehnologiju obrade. Za napomenuti je i vrlo bitna uloga kadrova jer u njih treba uložiti i do 4 puta više nego u opremu, naročito u višim fazama

razvoja tehnologije. Ovdje se ne smije zaboraviti na očuvanje ekologije i plodnosti tla, jer svako tko tlo obrađuje mora voditi računa da u budućnosti zadrži njegovu plodnost i pedofizičke osobine barem na onoj razini na kojoj je počeo s eksploatacijom.

Gledajući ekonomski primjenom racionalne obrade ostvaruje se izravna ušteda od 100 do 200 Eura/ha (17). Smanjuje se utrošak svih pesticida, te mineralnih gnojiva što je bitan ekološko-ekonomski moment. Osim toga time se smanjuje oprema, radna snaga i utrošak energije, što pojeftinjuje proizvodnju. Danas u Slavoniji i Baranji jedan djelatnik u većim gospodarstvima obrađuje 40 – 50 ha, a u razvijenim zemljama EU na jednog zaposlenog dolazi 400 – 600 ha

Da bi se primjenila bilo koja od ovih obrada bitno je znanje i iskustvo cijelog tima stručnjaka. Zakazivanjem bilo koga u timu propada cijeli projekt. Zato ga stručnjaci teže prihvaćaju i skloniji su konvencionalnoj obradi jer se učinjene greške mogu popraviti, što nije slučaj u racionalnoj obradi. Radi toga je grupa stručnjaka IPK Osijek i Poljoprivrednog fakulteta Osijek 1996. godine postavila trogodišnji makro pokus s konvencionalnom i izravnom sjetvom kukuruza u neobrađeno tlo (16,18,19). Nakon tri godine primjenom sijačice JD Max EmERGE 2 i korištenjem nove tehnologije dobivena su dragocjena iskustva i saznanja koja do tada nismo imali. Ostvareni manji prosječni prinosi na pokusnim parcelama u odnosu na kontrolnu površinu očekivani su i nisu obeshrabrujući jer se stabiliziranje i postepeno povećanje proizvodnje može očekivati u narednim godinama. Međutim, već se tada uočavalo da takva proizvodnja polučuje brojne ekonomske i ekološke efekte, što je utjecalo na promjenu razmišljanja i načina rada mnogih agronoma u Slavoniji i Baranji. Uporabom nove tehnologije uočeno je da se nakon tri godine povećala prirodna plodnost tla (10), a koja se ogledala u povećanoj populaciji kišnih glisti (simbola plodnosti tla), aktivirao rad korisnih mikroorganizama celulolizatora – razgrađivača organske tvari, što će u narednim godinama smanjiti količinu mineralnih gnojiva koja se obavezno ispiru u vodotokove i izravno djeluju na ljudsko zdravlje. Do gotovo istih ili približnih rezultata došli su i stručnjaci «HANA» Našice i Belje d.d. Darda.

Prijelaz na ratarsku proizvodnju bez pluga zahtjeva fazu prilagodbe i saznanja koja mogu trajati 3 do 5 godina tijekom kojih će se promijeniti struktura i život u tlu, te postići nova ravnoteža. No važno je zaključiti da gospodarjenje bez uporabe pluga nije neka ideologija, već samo posljedica ekološkog i gospodarskog procesa odlučivanja.

Tablica 1. prikazuje da su se predviđanja i obistinila, pa čak i premašila naša očekivanja.

Pri opremanju za izvođenje racionalne obrade krenulo se od sijačica za izravnu sjetvu – dakle odostrag. Nije nabavljena oprema za pripremu i njegu koja i danas nedostaje. Neka poljoprivredna gospodarstva nabavila su dubinske rahljače – osnovno oruđe za uvjet primjene racionalne obrade, dok ih mnoga uopće nemaju. Ovi koje posjedujemo nisu pravi izbor jer nisu aktivni pa troše i do 30% više energije, a i efekt im je kratkotrajniji.

U opremanju tehnikom vladaju različita mišljenja i uvjerenja o kvaliteti i tehnološkim karakteristikama strojeva. Rat nam je nanio puno zala pa i o promišljenom opremanju svih gospodarstava neovisno o veličini. Svi mislimo da sve znamo. No na žalost nije tako pa nam tehničko-tehnološka rješenja često nameću drugi što ima dalekosežne posljedice jer se javlja veliko šarenilo u strojevima pa onda i u tehnologijama što nam se kasnije dobro osvećuje.

Tablica 1. Načini obrade tla na gospodarstvima Slavonije i Baranje u 2001. godini

Gospodarstvo	Kultura	Konvencionalna	Racionalna	Nulta	Ukupno
		ha - %	ha - %	ha - %	ha - %
IPK Osijek	Pšenica	1.069 - 17	5.196 - 83	-	6.265 - 100
	Kukuruz	4.019 - 60	2.713 - 40	-	6.732 - 100
	Soja	1.240 - 63	736 - 37	-	1.976 - 100
	Suncokret	713 - 44	891 - 56	-	1.604 - 100
<i>Ukupno:</i>		7.041 - 42	9.536 - 58	-	16.577 - 100
Belje d.d. Darda	Pšenica	581 - 7	7.693 - 93	-	8.274 - 100
	Kukuruz	5.514 - 91,5	434 - 7	89 - 1,5	6.037 - 100
	Soja	2.983 - 100	-	-	2.983 - 100
	Suncokret	1.583 - 100	-	-	1.583 - 100
<i>Ukupno:</i>		10.661 - 56,5	8.127 - 43	89 - 0,5	18.877 - 100
«Hana» d.d. Našice	Pšenica	-	800 - 29	2.000 - 71	2.800 - 100
	Kukuruz	3.300 - 87	-	500 - 13	3.800 - 100
	Soja	400 - 50	200 - 25	200 - 25	800 - 100
	Suncokret	-	-	-	-
<i>Ukupno:</i>		3.700 - 50	1.000 - 13,5	2.700 - 36,5	7.400 - 100
Sveukupno:		21.402 - 50	18.663 - 43,5	2.789 - 6,5	42.854 - 100

Iz podataka o primjeni racionalne obrade uočava se da je ona po gospodarstvima različito prihvaćena i to od 13,5 – 43 - 58 %. To je odraz bojazni i shvaćanja pojedinaca ili timova. Jednih da zadovolje tehnologiju, a drugih koji gledaju na tehnologiju i profit da očuvaju koliko-toliko zatečenu plodnost tla. Kod izvođenja ove tehnologije vrlo smiono se napustio lemešni plug i priprema se ogledala u plitkom «ljuštenju» tla multitillerom ili kada je bilo puno biljnih ostataka na tlu (kukuruznjaka), primjenom tanjurače u jednom ili dva prohoda. Belje d.d. i OLT Osijek u izradi su rješenja kombinacije teške tanjurače ukomponirane u prednji dio multitillera s kojom se dobro «rješavaju» biljni ostaci i dobro sitni tlo za racionalnu sjetvu sijalicama posebne izvedbe. Slično rješenje izradio je IPK Osijek u suradnji s AG-Cretom.

Zakorovljenost se rješavala adekvatnim pesticidima, no na žalost ostala je prisutnost «efekta susjeda» i izostala higijena polja (rješenje korova s puteva i kanala koji su potpuno zapušteni i sada umjesto da odvede višak vode, postali su vjetro-zaštitni pojasevi. Radi njihovog zamuljenja dovedeno je u pitanje djelovanje prije rata postavljene drenaže, pa to uvjetuje poplave u najkritičnijim fazama razvoja usjeva što stvara velike nepovratne štete.

Sve u svemu postotak racionalne i nulte obrade u analiziranim gospodarstvima je izuzetno velik (43,5% + 6,5%), dakle premašuje naša i europska predviđanja. To je postalo pravilo razmišljanja, jedini put ka uštedama i racionalnoj proizvodnji, a time i jedinoj mogućnosti uključenja u europske i svjetske trendove kretanja. Nužno je potpuno

opremanje novom, za to potrebnom učinkovitom tehnikom, timskim radom stručnjaka pa uspjeh sigurno neće izostati.

ZAKLJUČAK

Na temelju naših višegodišnjih znanstveno-stručnih ispitivanja, provjeravanja učinkovitosti poljoprivredne tehnike i stečenih iskustava radom na gospodarstvima Slavonije i Baranje mogući su sljedeći zaključci:

- obrada tla i sjetva u prošlosti se obavljala isključivo na konvencionalan način uz racionalizaciju pojedinih operacija. Napredak se počeo osjećati uvođenjem traktora jačih snaga, univerzalnih kombajna i integriranih priključaka, te obrazovanjem mehanizatora i neposrednih izvođača tehničko-tehnološkog procesa.
- za primjenu racionalne i nulte obrade tla neophodno je grupiranje oraničnih površina, izrada kanalske i putne mreže uz ravnjanje, te odvodnju i navodnjavanje tih oraničnih površina.
- radi ekonomsko-ekoloških uvjeta neminovan je prijelaz na suvremeniji – jeftiniji način obrade. Izostavljanjem pluga (najvećeg potrošača energije) smanjuju se izravni troškovi, a intenziviraju mikrobiološki procesi u tlu koji povećavaju njegovu plodnost.
- umanjuju se potrebe pesticida i mineralnih gnojiva što omogućava proizvodnju zdravije hrane i očuvanje eko-sustava naših polja. Za ovo je neminovan timski rad različitih struka (multidisciplinarnost), te njihovo sigurno i provjereno iskustvo.
- rezultati s naših gospodarstava zadnjih godina su to pokazali i dokazali, pa je shodno tome moguće zaključiti da uvođenje racionalne obrade nije neka ideologija već samo posljedica ekološkog i gospodarskog procesa odlučivanja.

LITERATURA

1. BUCHNER, W., KÖLLER, K. (1990): Integrierte Bodenbearbeitung, Ulmer, Stuttgart
2. ČULJAT, M. (2001): Ako već krećeš od početka onda kreni kako treba, PUP 3/01., 6-8, PUP-intervju, Osijek
3. ČULJAT, M., ZIMMER, R. (2000): Agronomi i mehaniziranje poljoprivrede (od 1951. do 2000. godine), Monografija, DAO, Osijek
4. ČULJAT, M. (1990): Integralna poljoprivreda, Agrotehničar 9/90., 17-25, Zagreb
5. ČULJAT, M. (2001): Orati ili ne orati, PUP 3/01, 21-26, Osijek
6. ČULJAT, M. (2001): Sijačice jednosjemene, PUP 3/01. 14-18, Osijek
7. ČULJAT, M., KOŠUTIĆ, S., KRIČKA, T. (1999): Tehničke osnove preporoda hrvatske poljoprivrede, 35. znanstveni skup hrvatskih agronoma, 11-22, Opatija
8. KAHNT, G. (1995): Minimal-Bodenbearbeitung, Ulmer, Stuttgart,
9. KÖLLER, K. (1983): Mogućnosti i ograničenja obrade tla bez pluga, Agrotehničar 3/83., 10-13, prijevod, Zagreb

10. MILAKOVIĆ ,Z., ZIMMER ,R., BUKVIĆ, Ž., BRKIĆ ,S., JURIŠIĆ ,M. (1997): Microbiological soil activity caused by direct sowing in corn production. XVII Annual Meeting of ESNA jointly organised with VIR, proceedings Ghent/Belgium, 12-18, Working Group 3, Soil-Plant-relationships.
11. MILOŠ, B. (1992): Meliorativno-investicioni zahvati u tlu potrebni za primjenu ITBP, Znanost u poljoprivredi, 18-19, 8-19, Osijek
12. MILOŠ ,B., BABIĆ, M. (1989): Mehaničko uništavanje korova podrezivanjem, Agrotehničar 4/89. Zagreb
13. PELLIZZI, G., GUIDOBONO, C., LAZZARI ,A. (1988): Energy savings in agricultural machinery and mechanization, Elsevier, London, 143p.
14. STROPPEL, A. (1997): Oruđa za obradu tla u budućnosti, 25. međunarodni simpozij «Aktualni zadaci mehanizacije poljoprivrede», 125-129, Opatija
15. TEBRÜGGE, F., BÖHRNSEN, A. (1997): Utjecaj obrade različitog intenziteta na strukturu tla, biološku aktivnost u tlu, urod i profit, 25. međunarodni simpozij «Aktualni zadaci mehanizacije poljoprivrede», 129-139, Opatija
16. ZIMMER, R., MILOŠ ,B., MILAKOVIĆ, Z., KRŽEK, Ž. (1997): Usporedba konvencionalne i nulte obrade tla u proizvodnji kukuruza, 25. međunarodni simpozij «Aktualni zadaci mehanizacije poljoprivrede», 155-161, Opatija
17. ZIMMER, R., BRAČUN, M., KOŠUTIĆ, S., FILIPOVIĆ, D., POKRIVKA, A., VARGA, V. (2001): Izravna sjetva u proizvodnji soje, 29. međunarodni simpozij «Aktualni zadaci mehanizacije poljoprivrede», 171-179, Opatija
18. ZIMMER, R., MILAKOVIĆ, Z., MILOŠ, B., KRŽEK, Ž. (1999): Proizvodnja kukuruza izravnom sjetvom i razgradnja biljnih ostataka u tlu, 27. međunarodni simpozij «Aktualni zadaci mehanizacije poljoprivrede», 127-135, Opatija
19. ZIMMER, R., MILAKOVIĆ, Z., MILOŠ, B., KRŽEK, Ž., BANAJ, Đ. (2000): Izravna sjetva u proizvodnji kukuruza i razgradnja biljnih ostataka u tlu, 28. međunarodni simpozij «Aktualni zadaci mehanizacije u poljoprivredi», 159-169, Opatija

SOIL TILLAGE AND ARABLE CROPS SOWING PRACTICE IN SLAVONIA AND BARANJA

SUMMARY

The paper presents a chronological review of different soil tillage technique utilisation and efficiency on the greatest agricultural companies in Slavonia and Baranja; main arable regions in Croatia; during last 10 years. According to collected data, utilisation of conservation and no-till systems on the greatest agricultural companies has increased to 43.5%. Authors concluded that further promotion of these soil tillage techniques and implements must be continued in order to assure production costs decreasing.

Key words: *Soil tillage, conservation, no-till, arable production, Slavonia, Baranja*



PROIZVODNJA KUKURUZA RAZLIČITIM NAČINIMA OBRADE TLA

SILVIO KOŠUTIĆ, DUBRAVKO FILIPOVIĆ, *STJEPAN HUSNJAK
ĐURO BANAJ, *MARTIN BRAČUN

Agronomski fakultet, Zavod za mehanizaciju poljoprivrede

*Agronomski fakultet, Zavod za pedologiju

**Poljoprivredni fakultet Osijek

***Hana Našice d.d.

SAŽETAK

*Tri različita načina obrade tla testirano je u proizvodnji kukuruza (*Zea mays* L.) u sezoni 2000-2001. na močvarno glejno hidromelioriranom tlu središnje Slavonije. Testirani načini obrade bili su: 1. Konvencionalna obrada (plug, tanjurača, sjetvospremač), 2. Konzervacijska obrada (rovilo, tanjurača), 3. Nulta obrada (no-till sijačica). U vegetacijskom periodu 2001. godine bilo je 61.9% više oborina od prosjeka perioda 1990-2000. Najveći prosječan urod od 11.58 t ha⁻¹ postignut je konzervacijskom obradom, što je 8.4% više od konvencionalne obrade. Nultom obradom, u usporedbi s konvencionalnom obradom ostvaren je 10 % manji urod suhog zrna.*

Ključne riječi: *Obrada tla, konvencionalna, konzervacijska, nulta, kukuruz*

UVOD

U ratarskoj proizvodnji obrada tla dominira kao najveći potrošač energije. Od izravno utrošene energije za radove u polju 55-65% otpada na obradu tla, ukoliko se primjenjuje konvencionalni sustav obrade (Pellizi et al., 1988). Iako su istraživanja pokazala da se korištenjem nekonvencionalnih sustava obrade tla može uštedjeti iznimno mnogo energije i ljudskog rada, još i danas se cca 85% ratarskih površina središnje Europe obrađuje konvencionalnim sustavom obrade (Stroppel, 1997). Supstitucija konvencionalnog sustava obrade tla različitim varijantama konzervacijske obrade je danas u SAD dosegla zastupljenost na gotovo 40% ratarskih površina (Conservation Technology Information Center, 2000), a ovaj proces posljednjih godina dobiva i u Europi sve veći broj pristalica. Dva temeljna razloga koji su potaknuli ovu promjenu moguće je ponajprije obuhvatiti

ekološkim i ekonomskim razlozima. Naime, dugogodišnja primjena konvencionalne obrade u ratarstvu iskazala je značajne ekološke i ekonomske nedostatke. S ekološkog stajališta to su: povećanje zbijenosti tla izazvano prekomjernim gaženjem oranice strojevima, sustavno smanjenje sadržaja organske tvari u tlu (humusa) kao posljedicu intenzivnog i učestalog djelovanja ratila na tlo, veća podložnost konvencionalno obrađenih tala eroziji, te konačno značajna emisija CO₂ kao posljedica izgaranja velikih količina goriva nužnih za obavljanje ovog posla (Tebrügge i Düring, 1999). Višekratnim prelaženjem preko iste površine oranice, što je slučaj kod konvencionalnog sustava obrade tla, neizbježno je zbijanje oraničnog sloja kotačima traktora. Uz to, lemešni plug stvara na dnu brazde slabo propusan ili nepropusan sloj tla koji smanjuje ili čak sprječava komunikaciju rizosfere sa zrakom i oborinskim vodama. Intenzivno i učestalo mehaničko tretiranje tla ratilima, što je temeljna značajka konvencionalne obrade, narušava prirodni stabilitet strukturnih agregata tla, a zaoravanje žetvenih rezidua u dublje slojeve ostavlja površinu oranice izloženu eroziji. Nasuprot tome, inkorporacija žetvenih rezidua; što je osnovna značajka konzervacijskih sustava obrade; unutar površinskog sloja regenerira plodnost tla čineći protutežu antropogenom zbijanju tla i izloženosti tla eroziji (Weise i Bourarach, 1999). No-till sustav, kao najdrastičniji oblik odstupanja od konvencionalne obrade, pak ostavlja cjelokupne žetvene rezidue na površini. S ekonomskog stajališta nedostaci konvencionalnog sustava obrade tla su izrazito veliki utrošak energije i ljudsko-strojnog rada, veliki investicijski troškovi i troškovi održavanja strojeva, te u konačnici veći troškovi proizvodnje ratarskih usjeva (Kanisek et al. 1997, Štefanić et al. 1997).

METODE ISTRAŽIVANJA

Istraživanje je provedeno na proizvodnim površinama poljoprivrednog poduzeća Hana-Našice, pogon Lila. Pokusno polje dimenzija 300x120 m, koje je podijeljeno metodom randomiziranih blokova na 9 parcela dimenzija 100x40 m. Sustavi obrade, te strojevi i oruđa korišteni u ovom istraživanju su sljedeći:

1. Konvencionalna obrada (plug, tanjurača, sjetvospremač)
2. Konzervacijska obrada (rovilo, tanjurača)
3. Nulta obrada (no-till sijačica)

Dubina obrade lemešnog pluga bila je prosječno 30 cm, tanjurače 10 cm, a kombiniranog oruđa 6 cm. Rovilo je radilo s prosječnom dubinom 33 cm, a tanjurača 10 cm. Istraživanje je provedeno na močvarno glejnoj hidromelioriranoj tlu (Gleysols), teksturne oznake-praškasto glinasta ilovača. (Tablica 1).

Obzirom na osnovna kemijska svojstva, tlo je slabo kisele do kisele reakcije, dobro opskrbljeno fiziološki aktivnim hranjivima i srednjeg sadržaja humusa. U 2000. godini parcela je bila zasijana silaznim kukuruzom. Osnovna obrada lemešnim plugom i rovilom obavljena je tijekom mjeseca studenog 2000, dopunska obrada tanjuračom i sjetvospremačem 09.04.2001., a no-till parcele tretirane Cidokor-om. Osnovna gnojidba obavljena je 11.11.2000. sa 205 kg ha⁻¹ KCl, a startna gnojidba 05.04.2001. sa 150 kg ha⁻¹ KCl, 214 kg ha⁻¹ NPK (7:20:30) i 235 kg ha⁻¹ Uree. Sjetva hibrida Pioneer PR 37 M 34 obavljena je 14.04.2001. Tretiranje Dual-om, 1,3 l ha⁻¹ i Gesaprim-om, 2,5 l ha⁻¹ obavljeno

je neposredno iza sjetve. Kultivacija i prihrana sa 130 kg ha⁻¹ 27 %KAN-a obavljena 20.05.2001. Berba kukuruza je obavljena 16.10.2001.

Tablica 1. Mehanički sastav i teksturna oznaka tla

Table 1. Soil particle size distribution and soil type

Dubina Depth (cm)	Mehanički sastav (%) Particle size distribution (%)				Teksturna oznaka tla Soil type
	< 2 μm	2-20 μm	20-200 μm	200-2000 μm	
0-10	28.7	34.4	35.1	1.8	Prašasto glinasta ilovača Silty clay loam
10-20	29.8	35.8	33.0	1.4	Prašasto glinasta ilovača Silty clay loam
20-30	29.1	35.0	34.5	1.4	Prašasto glinasta ilovača Silty clay loam

REZULTATI ISTRAŽIVANJA

Obzirom na količinu i raspored oborina tijekom vegetacije kukuruza, 2001. godina je imala u svibnju 65.1% manje i kolovozu 68.0% manje oborina od prosjeka u periodu 1991-2000. Nasuprot tome u lipnju i rujnu je bilo 217% i 257% više oborina od prosjeka. Uzevši cijeli vegetacijski period 2001. godina je imala 61.9% više oborina od prosjeka. Usprkos dosta atipičnim klimatskim uvjetima u 2001. godini (posebice vlažan rujna), bila je to *relativno dobra godina za proizvodnju kukuruza*.

Tablica 2. Klimatski uvjeti na području Lile tijekom vegetacijske sezone kukuruza 2001. godine

Table 2. Climate conditions during maize growing season 2001. in Lila

Mjesec/ Month	Oborine/Precipitation 2001 (mm)	Oborine/Precipitation 1991-2000 (mm)	Prosječne temperature zraka Avg. air temperature (°C)
Travanj/April	55.1	55.1	9.5
Svibanj/May	28.6	81.9	15.9
Lipanj/June	308.1	97.3	17.8
Srpanj/July	61.6	83.0	21.6
Kolovoz/August	24.9	77.9	22.2
Rujan/September	295.1	82.6	14.1
Suma/Summ	773.4	477.8	

Krajem mjeseca svibnja 2001., točnije 31.05.2001. obavljena je kontrola usjeva i evidentiran sklop biljaka na pokusnim parcelama Tablica 3.

Tablica 3. Sklop biljaka po varijantama obrade tla

Table 3. Plant population according soil tillage system

Obrada tla Tillage system	Broj biljaka po ha/ Plant population per ha		
	Minimum	Maximum	Prosjeak/Average
Konvencionalna/ Conventional	66010	74877	69261
Konzervacijska/ Conservation	66995	71921	69064
Nulta/ No-till	52217	69951	62266

Prosječni sklop biljaka kukuruza u nultoj obradi je za 10.1 % manji od sklopa postignutog konvencionalnom obradom, dok je prosječni sklop u konzervacijskoj obradi neznatno manji od konvencionalnog načina obrade, (Tablica 3.). Razloga manjeg broja biljaka na parcelama s nultom obradom zasigurno ima više, ali jedan od utjecajnijih je sporije zagrijavanje tla u proljeće što utječe na sporije i neujednačeno nicanje i kasnije zaostajanje biljaka u rastu. Uz navedenu redukciju sklopa, logično je bilo očekivati i odgovarajuću depresiju uroda na parcelama s nultom obradom što se pokazalo točnim. Naime podaci u Tablici 4. podkrepljuju prethodne navode, jer je nulta obrada u usporedbi s konvencionalnom obradom ostvarila 10 % manji urod suhog zrna. Nasuprot tome, najveći prosječan urod od 11.58 t ha⁻¹ postignut je konzervacijskom obradom, što je 8.4% više od konvencionalne obrade. Treba naglasiti da su postignuti vrlo dobri urodi, gotovo dvostruko veći od 10-godišnjeg prosjeka (1985-1994) poljoprivrednih poduzeća Hrvatske, koji prema Statističkom ljetopisu (1995) iznosi 5.90 t ha⁻¹.

Tablica 4. Urod zrna (14% H₂O) po varijantama obrade tla

Table 4. Yield (14% H₂O) according soil tillage system

Obrada tla Tillage system	Urod zrna t ha ⁻¹ / Yield t ha ⁻¹		
	Minimum	Maximum	Prosjeak/Average
Konvencionalna/Conventional	8.99	11.77	10.68
Konzervacijska/Conservation	10.59	13.23	11.58
Nulta/No-till	8.19	10.39	9.61

Usporedba važnijih karakteristika (sadržaj vode u zrnu, volumna gustoća i masa 1000 zrna) kukuruza u berbi (Tablica 5.), pokazuje da je volumna gustoća zrna s nultom obradom cca 3.0% manja, a s konzervacijskom cca 1.0% manja od zrna s konvencionalnom obradom. Nadalje, masa 1000 zrna varijante s nultom obradom ima 2.8% manju masu od konvencionalne varijante, ali je masa 1000 zrna s konzervacijskom obradom 0.1% veća od konvencionalne.

Tablica 5. Sadržaj vode zrna u berbi, volumna gustoća i masa 1000 zrna

Table 5. Grain moisture content in harvest, volume density, 1000 kernal mass

Obrada tla/ Tillage system	Vlaga zrna/ Grain m.c. (%)	Volumna gustoća/ Volume density (kg m ⁻³)	Masa 1000 zrna/ 1000 kernal mass (g)
Konvencionalna/ Conventional	19.80	746.7	439.6
Konzervacijska/ Conservation	18.76	738.7	446.0
Nulta/No-till	20.70	725.2	427.3

ZAKLJUČAK

Kako je riječ o jednogodišnjim rezultatima, pretenciozno bi bilo donositi konačne zaključke. Evidentno je da je nultom obradom postignut 10% manji urod nego konvencionalnom, no činjenica je i da je sklop kukuruza s nultom obradom bio 10% manji nego onog s konvencionalnom obradom. Konzervacijskom obradom je postignut najveći prosječni urod suhog zrna kukuruza od 11.58 t ha⁻¹, što je 8.4% više od konvencionalne obrade. Daljnje istraživanje bi zasigurno trebalo usmjeriti prema detaljnom praćenju utroška energije obrade tla posebice, ali i ostalih agrotehničkih postupaka.

LITERATURA

1. CONSERVATION TECHNOLOGY INFORMATION CENTER, (2000) <http://www.ctic.purdue.edu/Core4/CT/ctsurvey/2000//GraphCTAll.html>
2. DRŽAVNI ZAVOD ZA STATISTIKU RH (1995) Statistički ljetopis. Zagreb.
3. KANISEK, J., PETRAČ, B., BUKVIĆ, Ž., ZUGEC, I., (1997) Economic efficiency of application of different soil tillage practices on winter wheat production in East-Croatia conditions. Proceedings of the 14th ISTRO Conference, Pulawy, Poland, 351-354.
4. PELLIZZI, G., GUIDOBONO CAVALCHINI, A., LAZZARI, M., (1988) Energy savings in agricultural machinery and mechanization. Elsevier Applied Science, London-New York.

5. STROPPEL, A., (1997) Soil tillage machines of the future. Proceedings of the 25th International Symposium "Actual Tasks on Agricultural Engineering", Opatija, Croatia. 125-128.
6. ŠTEFANIĆ, I., ŠTEFANIĆ, E., PETRAČ, B., (1997) Economic analysis of different tillage management in north-east Croatia. Proceedings of the 14th ISTRO Conference, Pulawy, Poland, 597-600.
7. TEBRÜGGE, F., DÜRING, R.A., (1999) Reducing tillage intensity - a review of results from a long-term study in Germany. *Soil & Tillage Research* 53: 15-28.
8. WEISE, G., BOURARACH, E.H., (1999) Tillage Machinery. In: CIGR Handbook of Agricultural Engineering, Vol. 3: Plant Production Engineering, ASAE, St. Joseph, 184-217.

MAIZE PRODUCTION BY DIFFERENT SOIL TILLAGE SYSTEMS

SUMMARY

*Three different soil tillage systems were monitored in maize (*Zea mays* L.) production during growth season of 2001. on Gleysols soil in central Slavonia. Monitored systems were: 1. Conventional soil tillage (plough, discharrow, seedbed implement), 2. Conservation tillage (chisel plough, discharrow) and 3. No-till. During growth season 2001. there were 61.9% more precipitation than 1990-2000 average. The greatest average yield of 11.58 t ha⁻¹ achieved conservation tillage system, which was 8.4% more than conventional tillage. No-till system achieved 10% lower yield than conventional tillage system.*

Key words: *Soil tillage, conservation tillage, no-till, maize*



THE RESEARCHES CONCERNING THE EXPERIMENTATION OF THE PLOUGHS REVERSIBLES IN THE AGGREGATE BY THE TRACTORS OF 65-110 HP

ȚENU IOAN

Technical University "Gh. Asachi" Iași
Faculty of Mechanics
Romania

SUMMARY

The ploughing quality influences both the agriculture output level and the total cost per obtained product unit. For optimisation these inquires, it has been assimilated in fabrication under KUHN COMPANY license, the reversible plough (in aggregate by tractors of 65, 80, 110) by 2 or 3 skimmers. For determination the exploitation parameters of the reversible ploughs, it was achieved tests on the heavy soil which are specific for agricultural land from ROMANIA.

Key words: *plough, ploughing, agrimotor, exploitation.*

INTRODUCTION

After 1990 Romanian's agriculture is finding in the continuous transformation as it passed from the state property at private property.

In the present day, and especially in the future, Romania's agriculture policy is to meet the European Union's agricultural policy directives. But, the fundamental principles of the European Union's agricultural policy stipulates: the oneness of the market, communitaire preference, the financial solidarity and free circulation of agriculture products on the competitiveness basis. The last criterion can be met by agriculture farmers from Romania only if they will have in view the following recommendations:

- the agricultural exploitations are to have optimum dimensions of 200-500 ha on the hilly areas and over 1000 ha on the field area;

- they must use only seeds of high quality species ;
- they must use advanced technologies (production of high performances, rational irrigation and the efficient use of the chemical products) .

For doing possible the use of advanced technologies it is necessary that the agricultural farms are to be equipped properly with tractors and agricultural machines. Taking in consideration these essential requirements at SC IMA SA Iasi has been assimilated under KUHN company, the reversible plough with 2+1 plough bottoms. For establishing at the technical and operating performances, it has been carried out tests, on the specific conditions of the soils from Romania.

METHODS

For establishing of the working indices and of the operating performances of the PRP 3x35 reversible plough, it has been achieved tests on the different categories of soils and into aggregate with tractors of 65, 80 and 110 HP.

The reversible plough with 2+1 plough bottoms and with the length of the one operation organ up to 35 cm is made up from the following compounds (fig.1):

- the coupling device of the plough (1) of type carried;
- the reversing mechanism of the plough frame (2), driven by a hydraulic cylinder (3);
- the frame plough (4) is made up from two dismantable section, so that, the plough can work with three plough bottom or only with two, through demounting of the last section, depending on energetical source or of the soil category.
- the body of plough(5) left and right mounted simetrically, oposite of the frame, have in their composition semihelical mouldboards (6), but the share (7) are trapezoidal with reversible chisel (8).

The mouldboards are achieved from triplex to which the active surface has a thickness of 3.3mm, has a hardness at least 40% bigger than others levels. This makes that the wearing to be a lot diminished and to increase the machinery reliability. The shares, as well as, the knives of type chisel are achieved from such a material that allows autosharpening during the work. The body of the plough is protected at overloading by calibrated bolts stressed at stretching; the body plough length=35cm:

- the skim-coulter (9) made up from the same elements as the bodies of ploughs assures an increase of the operating quality indices of the plough, respectively the covering and breakage grade; the skim-coulter length is of 15 cm;
- the supporting wheel (10) tiltable, adjustable on vertical plane allows the modification of the operation depth.

By positioning of the supporting wheel on the rear part of the plough and for a right adjustment, it assures an overloading of the live rear axle of the agrimotor. For this, it recommends to respect the condition of assembling of the plough, opposite of, agrimotor, so that, during at operating, the lateral tension rod of the agrimotor must be inclined and to form with the horizontal plane an angle of 6-7°.

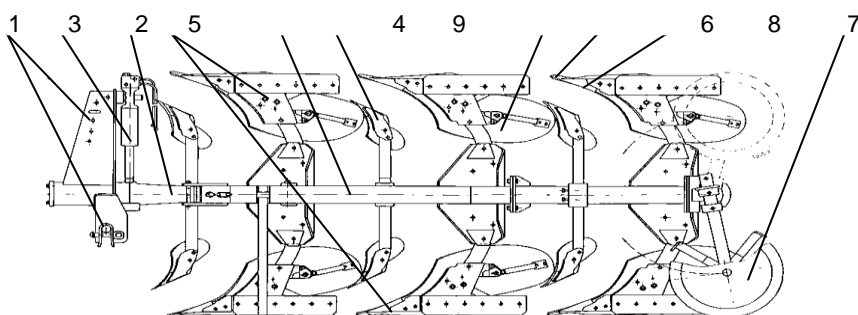

Figure 1. The reversible plough PRP 3x35 with 2+1 plough bodies; 1- the coupling device of the plough at agrimotor; 2-rotation mechanism of the plough frame; 3- the hydraulic cylinder for the action of the rotation mechanism; 4-the plough frame; 5-the left and right plough bodies; 6-mouldboards; 7-shares; 8-reversible chisel; 9- skim-coulter; 10-the supporting wheel.

For determination of the working qualitative and energetic indices of the reversible plough, it has been carried out, tests using as a energetical source: the agrimotors (U 650) of 65HP with driving simple, (U850DT) of 83 HP by double driving and (U 1010 DT) of 100HP by double driving. For the measurement of the energetical indices (strecthing resistance, fuel consumption per hour) it has been used the dynamometer and a special installation for measurement of the quantity of consumed Diesel fuel.

Depending on right conditions for achieving of the agricultural ploughings and before starting tests it must do the folowing intervention to the plough:

- the regulation of the earthwork depth;
- the regulation of the working width of the first plough body;
- the regulation of the operation lenght total of the plough;
- the regulation of the position and of the working depth of the skim-coulter;
- the regulation of the rotation mechanism of plough;
- the regulation of the horizontality of the plough frame.

The experimental tests have been effected on a soil with the following characteristics: the type: chernozem, specifical resistance at ploughing 0.65-0.68 daN/cm²; the humidity of soil 22-23%, the slope of ground by 0-3% and 12-14%; the state of soil surface – stubble after rye, with a quantity of 680 gr./m² vegetable remains.

RESULTS AND DISCUSSION

The experimental tests followed the determination of the earthwork qualitative indices: energetical and exploitation indices of the reversible plough into aggregate with agrimotors of: 65HP (U650), 83HP (U850 DT) and of 100HP (U1010 D).

As energetical and operation qualitative indices it has been in view the following : a – average depth, B – average width, Gm – breaking grade, Gac – covering grade of the vegetable residual, Ga – soil loosening grade, Rt – tension strenght; Vm – average speed,

δ - shipping, P_e – effective power, G_i – loading grade of the agrimotor and q – fuel average consumption per hour.

The values of these parameters are presented in the table (1). For the determination of exploitation indices (K07 - the usage coefficient of the working shift; K21 – the usage coefficient of the turning time; K23- technological servicing coefficient; K31 – technical maintenance coefficient; K4 – safety operation coefficient; K42 – technical safety coefficient, W_{ef} – the operation capacity at effective time, Q – specific consumption of fuel) it followed each agricultural aggregate during the achievement of ploughing at the depth of 22-25 cm, on a minimum surface of 30 ha. The results of these tests, concerning to the exploitation indices are presented in table (2).

Table 1. Energetical and earthwork qualitative indices of the reversible plough PRP-3x35 into aggregate with agrimotors 65-100 HP

Agrimotor type	a_{med} [cm]	B_{med} [cm]	G_m [%]	G_{ac} [%]	G_a [%]	R_t [daN]	V_m [km/h]	δ [%]	P_e [CP]	G_i [%]	q [l/h]
The slope of the field 0 – 2%											
U 650	20,2	98,2	68,3	91,3	23,0	1190	6,6	12,2	49,5	76,2	11,41
	25,1	99,2	67,6	93,4	22,3	1686,4	5,4	14,9	54,1	83,2	12,48
	29,8	69,4	66,1	94,3	23,6	1411,6	5,8	13,5	51,7	79,5	11,92
U850DT	20,6	101,2	77,3	92,6	26,4	1301	7,2	11,2	53,9	67,3	12,4
	24,8	103,0	74,5	94,5	26,8	1748	7,1	11,5	63,5	79,3	14,65
	29,6	103,5	73,6	95,6	27,0	2180	6,9	12,2	71,8	89,7	16,56
U1010DT	20,8	104,1	84,3	93,2	26,8	1330	7,8	10,8	56,9	56,9	13,13
	25,1	105,3	82,4	95,8	27,2	1785	7,6	11,2	67,1	67,1	15,48
	30,2	105,5	80,5	96,7	27,4	2200	7,2	12,1	74,3	74,3	17,14
The slope of the field 10 – 12%											
U 650	20	95,2	67,2	86,7	21,2	1192	6,4	13,2	49,9	76,8	11,52
	25,1	96,3	65,4	87,8	20,3	1630	5,7	15,3	55,7	85,7	12,65
	30,1	68,3	64,5	88,3	22,4	1485	5,2	14,6	50,6	77,8	11,64
U850DT	20,3	98,4	73,3	87,6	24,4	1230	6,8	11,8	51,9	64,5	11,99
	24,2	99,3	69,8	88,9	24,8	1690	6,6	12,1	60,7	75,9	14,04
	30	99,8	68,9	90,1	25,2	2090	6,4	14,8	68,6	85,7	15,87
U1010DT	20,3	101,7	77,6	89,6	25,6	1310	7,5	11,2	56,3	56,3	13,02
	24,8	103,8	76,3	90,8	26,3	1762	7,3	12,1	66,2	66,2	15,29
	30,1	104,2	74,4	91,3	26,8	2190	7,2	13,4	75,6	75,6	17,46

Analysing the experimental data presented on table 1, it results that PRP-3x35 – reversible plough into aggregate with agrimotor of 65-100 HP has a good stability on

horizontal and vertical plane. This aspect is demonstrated of the fact that the variation indices of the earthwork depth and width has not exceeded the maximum value $\pm 3\%$.

The breaking grade (G_m) has been influenced in the great part by the strong settling of the soil. But, however it finds that because of the proper geometry of the mouldboards and especially the being of the skim-coulter have allowed the achievement of the one breaking grade very well with values comprised between 61.2 – 84.5%.

The breaking grad reduces in the same time with the increasing of the depth and records upper values once with the majority of the operation speed of the aggregate. During the slope of ground increas it finds also a reduction of the breaking grade.

The incorporation grade into soil (G_{ac})of the vegetable remains has recorded high values between 86.7% and 96.7%. The values increases for the aggregate which runs with high speed and at which the operating width is bigger.

Table 2. The exploitation indices of the agricultural aggregate at the ploughing with 24 – 26 cm depth.

Indices	The slope of the field [%]	Agrimotor type from aggregate		
		U 650	U850DT	U1010DT
K07 - the usage coefficient of the working shift	0-2	0,69	0,72	0,74
	10-12	0,67	0,71	0,72
K21- the usage coefficient of the turning time	0-2	0,89	0,91	0,94
	10-12	0,86	0,89	0,93
K42 – technical safety coefficient	0-2	0,97	0,98	0,98
	10-12	0,97	0,98	0,98
K4 – safety operating coefficient	0-2	0,96	0,98	0,98
	10-12	0,95	0,98	0,98
K23- technological servicing coefficient	0-2	1,00	1,00	1,00
	10-12	1,00	1,00	1,00
K31- technical maintenance coefficient	0-2	0,96	0,97	0,98
	10-12	0,95	0,98	0,98
Wef – the operating capacity at effective time [ha/h]	0-2	0,476	0,665	0,752
	10-12	0,472	0,583	0,705
Qv – specific consumption of fuel [l/ha]	0-2	26,2	22,03	20,38
	10-12	26,8	24,08	21,68

From point of view of the specific resistance of the ploughed soil, although these values have been framed on the category of the medium soils, at tests, it has been recorded bigger values because of the setting of the soil during harvesting.

On earthwork condition at one depth of 24-26cm, the operation aggregates have achieved an effective operation capacity (W_{ef}) of 0.472-0.752 ha/h, with a (Q) fuel specific consumption of 20.38 – 26.8 l/ha, depending on the energetical source and slope of the ground.

CONCLUSIONS

From the analysis of the obtained data at tests it has resulted the following:

- ❖ PRP 3x35 plough into aggregate with agrimotors of 65 – 100 HP it has been achieved the ploughings of quality, with closed and levelled furrow, with high breaking grade of the soil and incorporation of the vegetable remains and obtaining the following qualitative and energetical indices:
 - the breaking grade of soil $G_b = 64.5 - 84.3\%$;
 - the incorporation grade into soil of the vegetable remains $G_{ac} = 86.7 - 96.7\%$;
 - the affining quality of the soil $G_a = 20.3 - 27.0\%$;
 - operation speed $V_m = 5.2 - 7.8$ km/h;
 - operation capacity at the effective time $W_{ef} = 0.472 - 0.752$ ha/h;
 - fuel consumption $Q = 20.38 - 26.8$ l/ha.
- ❖ Technological and technical safety coefficient have recorded high values, unbeing necessary times for repairing of exploitation defects, excepting the safety bolts.
- ❖ The plough PRP 3x35 into aggregate with the agrimotors of 65-100 HP has satisfied entirely the agrotechnical requirements.
- ❖ By the assimilation on fabrication of the PRP-3x35 plough and the equipping of the agricultural farmers with this machinery will be recorded the following advantage:
 - it increases the operating capacity of the agricultural aggregate with 5-30%;
 - the reduction of the fuel consumption on hectare with over 15-20%;
 - the preservation of the soil through the reduction of the settling, but on the soils in slope the ploughing is achieved with the overturning of the furrow towards upstream and the diminishes itself;
 - the elimination of the imports of such ploughs.

REFERENCES

1. SCRIPNIC V., ș.a, (1984), Mașini agricole, Ed. Ceres, București, pag.123-131;
2. TĂMAȘANU D., (1986), Mașini cu organe rotative pentru prelucrarea solului, Ed. Ceres, București, pag. 98-108;
3. ȚENU I., (1999), Mașini combinate pentru pregătirea patului germinativ, Mecanizarea agriculturii, Nr.3, Ed. Ceres, București, pag.26-31.



THE RESEARCHES CONCERNING THE EXPERIMENTATION OF THE HARROWES WITH VERTICAL ROTORS IN AGGREGATE BY THE TRACTORS OF 65-110 HP IN THE WORKING CONDITIONS FROM ROMANIA

ȚENU IOAN

Technical University "Gh. Asachi" Iași
Faculty of Mechanic
Romania

SUMMARY

The preparing of the germinating layer for sowing influences in the large part the obtained production level. For avoiding the loses of water from the soil and a reducing of the passing number by agriculture unit per surface unit, it has been assimilated under KUHN COMPANY – license harrow by vertical rotors. The experimentation of these machinery in the working conditions from ROMANIA, it was achieved on the heavy soil and different humidity.

Key words: harrow, agrimotor, exploitation, germinating layer.

INTRODUCTION

In the present day of the opened market economy and in the future, the development of the construction for technical equipment from agriculture has at the basis, legislative settlements; comercial and technical settlements properly the specific ratio – DEMAND-OFFER.

Going from this concept and analysing the mechanization technology of the earthwork, it can find that the workings for preparation of the germinating layer have a great importance for the crop, which is to be established.

For the achivement of this working complex in Romania it uses more individual aggregate, which usually performs only one technological operation such as: ploughing,

discing, fertilization, levelling, herbicidation. The use of this technology has a range of disadvantages, which the most important find in the following :

- the time period needed for the establishing of the crops is great;
- repeated crossing of the aggregates on the same surface carries out the compaction of the soil;
- the consumption of the fuel for the prepared surface unit increases a lot;
- it occurs important humidity losses by returning of the furrow during the ploughing or by transfer of the soil from very low levels towards surface during discing;
- preparing of the germinating layer by harrow with disks on dry condition, especially through more crossings, it determines a calibration of the clodearths, without being possible the breaking them.

These deficiencies can be removed totally or partially by use of the harrow with vertical rotors, instead of the harrow with disks.

Taking in consideration these problems, at the SC IMA SA Iasi, it has been assimilated on fabrication under KUHN company license, a combined machine made up from a harrow with vertical rotors, levelling blade and packer roller.

METHODS

For effecting of the experimental tests on field laboratory conditions it was used FRV-250 rotative harrow into aggregate with: universal agrimotor with a live rear axle of 65HP (U650); universal agrimotor by integrate drive of 83HP(U650 DT) and universal agrimotor by four wheel drive of 100HP(U1010 DT). The purpose of these experiments has been for establishing the exploitation optimum condition of the aggregate for preparing the germinating layer.

The rotative harrow (fig.1) is of type with vertical rotors and it is compounded from the following components:

- the coupling device of the harrow to agrimotor (1);
- the central driving mechanism (2), includes a spur gear transmission, replaceable between them and bevel gear having a role of reductor;
- driving mechanism of the active elements (3), formed from spur gears driving;
- operating organs are of type blades (4), as a “L” fixed on rotor flanges;
- the levelling blade, reglable on vertical plane it is mounted on the harrow frame; in front or rear of rotative operation element;
- packer roller (5) is mounted as on joint opposite of the harrow frame by two brackets which have the possibility to be regulated on height;
- the lateral walls (6) of the harrow limits the soil dislocation which is moved of the working parts.

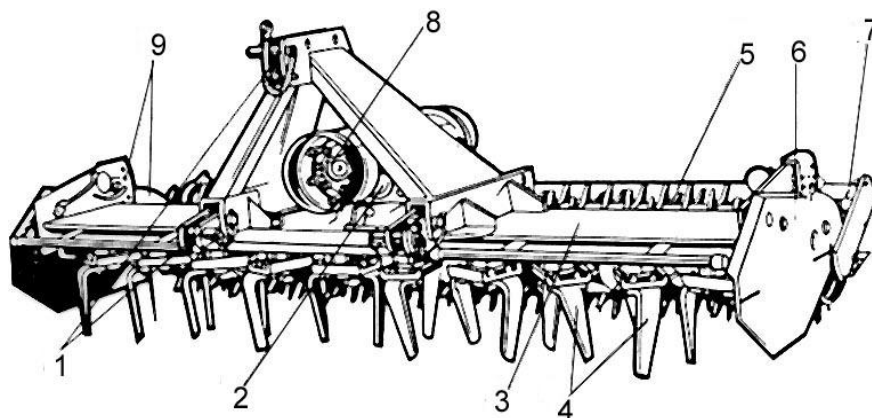

Figure 1. Rotary harrow FRV-250; 1- mechanism for the coupling of the harrow to the hydraulic jack of the agrimotor; 2- central driving mechanism; 3- the driving mechanism of the rotary organs; 4- the operating parts, type blade and as a form “L”; 5- packer roller; 6- lateral walls; 7- scraper support; 8-safety clutch; 9-mechanism for the regulation of the operating depth.

For assuring of one optimum exploitation, depending on the earthwork conditions, the harrow allows the achievement of the following adjustments:

- the harrow mounts on the hydraulic jack of the agrimotor, fixed by three points but during functioning is to assured for the cross transmission on inclination of maximum 30° , an overlapping of the telescope shaft of minimum 220mm and a distance of minimum 10mm between the halfend of the preview shaft and the fork of rear halfshaft;
- the safety clutch, positioned on the main transmission is to be regulated depending on the driving twist moment value of the operating elements, without the slipping of the clutch disks, and in the same time to assure also a protection of the operating organs in case of locking. These operation conditions are achieved by the prestress of the springs, so that, their length is to be aprox.35mm;
- the regulation of the operation regime of the harrow rotors. The central transmission allows the modification of the operation regime of the rotors, depending on the operation right conditions and the rotation of the power take off (PTO) to the energetical source (table 1);
- the regulation of the earthwork depth it makes by limiting of the running up of the fixing brackets of the packer roller. The operation depth of the active parts can be regulated on levels from 2.0 cm up to 20 cm;
- the regulation of the position of the levelling blade depending on operation conditions;
- the adjustment of position of the scrapers opposite of working surface of the roller parker. Distance between scraper and the roller parkes surface is to be of 1.5-2.5 mm.

Table 1. The ajustement of the rotors of the harrow

Rotation of the power take off [rot/min]	The erection position of the pinions					
	$z_1=21$	$z_1=24$	$z_1=19$	$z_1=26$	$z_1=17$	$z_1=28$
	$z_2=24$	$z_2=21$	$z_2=26$	$z_2=19$	$z_2=28$	$z_2=17$
540	221	289	185	346	154	417
750	307	402	257	-	214	-
1000	410	-	345	-	285	-

For the heavy and dried soils the levelling blade is mounted on rear of rotative operation parts, but for light soil the levelling blade is mounted in front of the harrow.

For the measurement of the energetical indices, it has been used the dynamometer and a special installation for the registration of the consumed fuel.

RESULTS AND DISCUSSION

The tests has been effected on the field laboratory, on a ploughing with the depth of the 25-26cm chernozem , with a specific resistance to plough of 0.6-0.65 daN/cm² and the humidity 14%.

Within the measurements it has been measured or calculated the following indices:

- qualitative indices of work: the operation width (B); the breaking grade (Gm) (the clod earth size maximum 40 mm) and the levelling grade (Gni); with maximum variation of 50mm;
- energetical indices: stretching resistance (Rf); shipping (δ); fuel average consumption per hour (g) and consumed power (Pe);
- exploitation indices: (K07 – the usage coefficient at the operation time); K21- the usage coefficient of the turning time; K4 - safety coefficient into exploitation; W_{ef} - the operation capacity of the worked effective time; Q- specific consumption of fuel.

The operation indices of the aggregate for the preparing of germinating layer have been determinated for the different operation regime of the FRV250 narrow such as: for the working depth of 10, 15 and 20cm; for the running speed of 3.8, 5.7 and 7.8km/h and for the relations of the operation part of 185, 221 and 289rot/min.

During tests, for satisfying the need of power into functioning regime, it has been used as energetical source: the agrimotors of 65, 83 and 100HP. The tests results are presented on table 2.

Table 2. Qualitative indices of work, energetic and exploitation for the FRV 250 harrow into aggregate with agrimotor of 65-100HP.

Operating speed [km/h]	Operation depth [Cm]	Rotation of rotors rot/min	G _m [%]	G _{ni} [%]	P _e [CPI]	R _r [daN]	q [l/h]	Q [l/ha]	B [cm]	Δ [%]	W _{ef} [ha/h]	K ₀₇	K ₂₁	K ₄	
3,8	10	185	93	87	46	190	8,3	9,8							
		221	95	88	54,5	185	9,6	11,4	250	8,3	0,84	0,84	0,89	1,00	
		289	97	90	63,6	186	11,5	13,7							
	15	185	91	84	59	260	10,6	12,9							
		221	94	86	66,2	256	12,1	14,7	250	11,8	0,82	0,82	0,86	1,00	
		289	96	87	72,3	252	13,1	15,9							
	20	185	88	82	63,1	390	11,5	14,3							
		221	90	83	72,8	382	13,2	16,5	250	14,1	0,8	0,80	0,85	0,99	
		289	93	85	79,5	372	14,3	17,8							
	5,7	10	185	90	85	52	232	9,4	7,3						
			221	92	87	63,2	228	11,6	9,1	250	9,6	1,28	0,83	0,90	1,00
			289	94	88	72	220	13,0	10,2						
15		185	87	83	68,1	320	12,3	9,8							
		221	89	84	79	288	14,2	11,3	250	13,1	1,25	0,82	0,88	1,00	
		289	91	85	84,3	276	15,2	12,1							
20		185	85	80	70,2	520	12,7	10,2							
		221	87	82	79,4	492	14,3	11,5	250	15,6	1,24	0,8	0,87	0,98	
		289	88	84	86,3	484	15,5	12,5							
7,8		10	185	86	84	63,1	264	11,4	6,55						
			221	88	86	67,9	255	12,2	7,0	250	9,4	1,74	0,84	0,89	1,00
			289	91	87	76,4	248	13,7	7,9						
	15	185	82	80	74,3	420	13,4	8,0							
		221	85	82	83,9	396	15,2	9,1	250	12,7	1,67	0,82	0,86	1,00	
		289	87	83	92,4	380	16,6	9,9							
	20	185	78	79	77,8	621	14,0	8,4							
		221	81	82	86,4	589	15,5	9,4	250	14,6	1,65	0,8	0,85	0,98	
		289	83	82	98,5	574	17,7	10,7							

From the analysis of the experimental tests presented in tab.2 it results that FRV250 rotary harrow into aggregate with the agrimotors of 65-100HP has a good behaviour in operation, aspect demonstrated of the fact that the qualitative indices values of work is high and the germinating layer prepared with this type of machine is properly to agrotechnical requirements.

So the breaking grade (to which the clod earth size does not exceed 40mm) at one crossing has the values comprised between 78% and 97%.

The maximum values obtains at small operation speed and high rotation for the harrow rotor. Although, we have to say that at the high rotation of the harrow rotor appears the degradation of the soil structue, especially for the soils with low humidity.

The levelling grade has values comprised into very narrow limits, respectively between 79 and 90% and it is not influenced significantly of the operating conditions of the harrow.

The energetical indices of the aggregate, the consumed power, stretching resistance and the fuel consumption per hour, depends on the operation depth of the harrow, the running speed of the agricultural aggregate and of the operation element rotation.

Analysing the energetical indices values it results that the rotary harrow can work into aggregate with the agrimotors of 65 and 83HP only for low operation depth and running speed. Regarding to the exploitation indices, it can find that, the harrow with vertical rotors works in very good conditions within aggregate with the agrimotor U1020 DT and partially with the agrimotor U850 DT. In this situation the agricultural aggregate achieves a high productivity and low specific consumption on the surface unit. During the tests the harrow has behaved quite well from point of view of the technical safety, being necessary only interventions for the regulation of clutch and change of the ratio for the driving of the rotors.

CONCLUSIONS

From the analysis of the obtained results on the laboratory field conditions it results that the agricultural aggregate for the preparing of the germinating layer, which includes the harrow with vertical rotors FRV250 achieves operation indices as follows:

- the operation depth into ploughed area: 6-20 cm;
- the breaking grade of the soil: 78-97%;
- the levelling grade of the earth: 79-90%;
- the stretching resistance of the harrow: 185-621daN;
- the fuel consumption per hour: 8.3 – 17.7 l/h;
- fuel specific consumption : 7.0 – 17.8 l/ha;
- working capacity 0.8 – 1.74 ha/h;

Concluding, taking in consideration the obtained experimental results and the analysis effected to agricultural earthwork, we can find the following aspects:

- the harrow into aggregate with the agrimotor of 100HP assures a properly preparing of the germinating layer on a depth of up to 20 cm. In the same time with the breaking and affinage of the soil it can achieve also a settling in profundity creating optimum conditions for the seeds which is to be introduced into soil;
- the earthwork qualitative indices achieved of the vertical rotary harrow are superior to those ones types of machines used for the preparing of the germinating layer (the harrow with disks, cultivators).

Assimilating into fabrication the harrow with vertical rotors, it makes a qualitative jump concerning the performance of the machines for earthwork achieved in Romania.

REFERENCES

1. SCRIPNIC V., ș.a, (1984), Mașini agricole, Ed. Ceres, București, pag.123-131;
2. TĂMAȘANU D., (1986), Mașini cu organe rotative pentru prelucrarea solului, Ed. Ceres, București, pag. 98-108;
3. ȚENU I., (1999), Mașini combinate pentru pregătirea patului germinativ, Mecanizarea agriculturii, Nr.3, Ed. Ceres, București, pag.26-31.

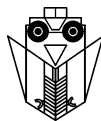

PENDULUM-METER FOR SITE SPECIFIC FARMING

DETLEF EHLERT, KARL-HEINZ DAMMER, ULLRICH VOELKER

Institute of Agricultural Engineering
Potsdam-Bornim, Germany

SUMMARY

A new sensor (pendulum-meter) was developed in past years for vehicle based measuring grown plant mass in cereal and grass. Because of positive results, this sensor was tested in the years 2000 and 2001 for real-time variable rate application of agro-chemicals in winter wheat under practical conditions. For this purpose the sensor was mounted in front of a tractor. In combination with a field sprayer and a fertiliser spreader the sensor was used for the site specific application of nitrogen fertiliser and fungicides. According the regional conditions (dry stress in the growing period) the application rates were reduced in sites with low plant mass and increased in sites with high plant mass. Field trials were carried out to compare the variable rate technology with the uniform treatment.

In the years 2000 and 2001 the results of site specific fertilising was that 19 - 48 kg ha⁻¹ Calcium-Ammonium-Nitrate could be saved and about 1 dt ha⁻¹ more yield was obtained. The grain quality was not significantly influenced by low or high fertilising rates.

In the fungicide experiments there were savings due to the site specific treatment of nearly 10 to 15 % (year 2000) and nearly 25 % (year 2001) of the spray mixture in comparison to the uniform treatment. There were no yield reduction and no higher disease occurrence.

The positive results of first operation of the pendulum-meter under practical field condition are completed by low costs and the easy handling.

Key words: *precision agriculture, nitrogen fertilising, fungicide application, sensor pedulum-meter*

INTRODUCTION

Precision farming has the potential for improvement crop production toward more efficiently and environment friendly. An important prerequisite for precision agriculture are suitable sensors for relevant soil and crop parameters.

In the last years a mechanical sensor (pendulum-meter) was developed for measuring grown plant mass (Ehlert, 2000) in plant populations (Figure 1).

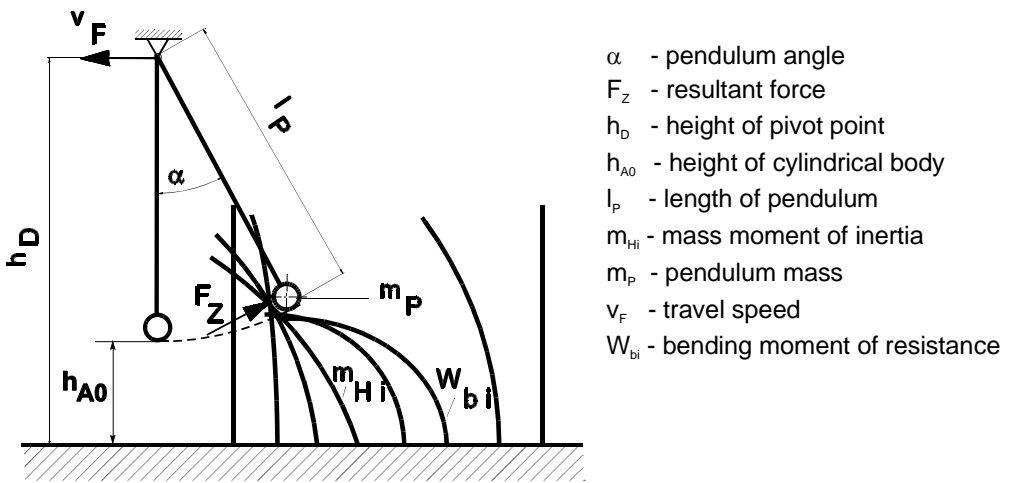

Figure 1. Measuring principle of pendulum-meter

To investigate the accuracy and to optimise parameters of pendulum-meter under defined conditions a dynamometer was developed (Figure 2).

For some stem crops (winter wheat, winter rye, rice, grass) the relations between pendulum angle and plant mass for different parameter combinations (height of pivot point, length of pendulum and specific pendulum mass) were estimated. For suitable pendulum parameters the goodness of fit is more than 0.9 (Figure 3).

Based on these good results, the possibilities for practical use of pendulum-meter in precision farming for yield mapping, plant protection and nitrogen fertilising were investigated. In this paper two year results in site specific management by the pendulum-meter are presented.

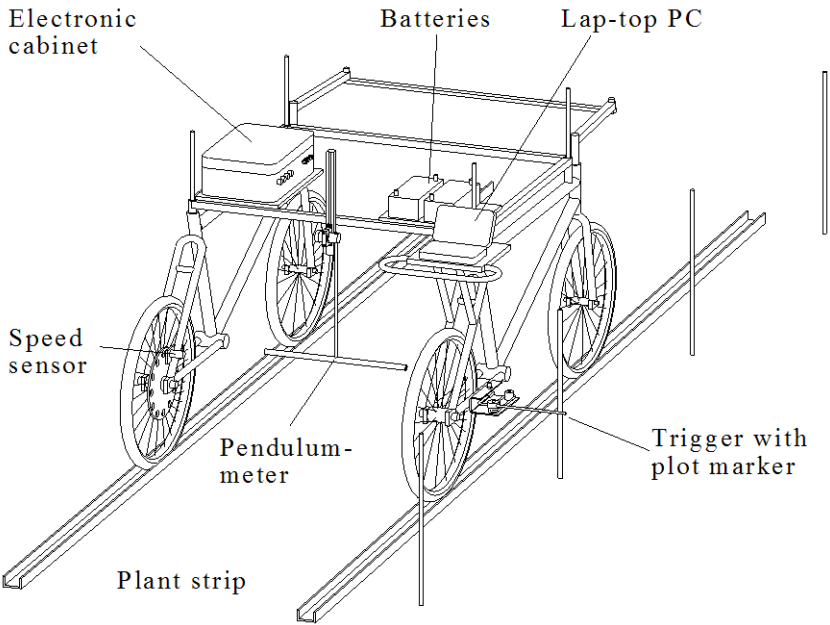

Figure 2. Dynamometer with pendulum-meter, sensory and electronic equipment.

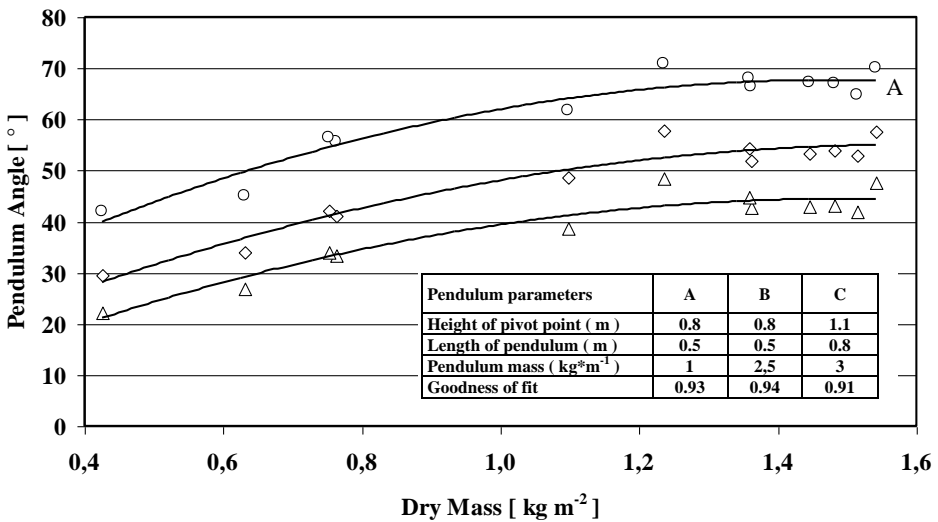

Figure 3. Example for the functional relation between plant mass and pendulum angle Nitrogen Application

Soil sample-based nitrogen application in precision farming is very expensive in cost and labour. There are a lot of no answered questions how to take the samples in the fields. Because of them the soil sample-based nitrogen application is no solution for precision agriculture under practical conditions.

The company Hydro agri offers a nitrogen sensor using spectral analyses of reflectance in plant populations for estimating the needed amount of nitrogen-fertiliser (Marquering et al. 1997, Schwaiberger, 2001).

An other method is based on the laser-induced-fluorescences for estimating the chlorophyll content in the leaves of grain plants for site specific nitrogen application (Günther et al., 1999).

The objective is the use of pendulum-meter for sensor-based 3rd application of nitrogen fertiliser in real-time under practical field conditions.

Fungicide Application

Because of a different vegetation (plant mass) of the cultivated crop in heterogeneous fields, a different plant surface has to be sprinkled by the spray mixture. On the other hand the present vegetation at a certain time is correlated with yield. A different formation of yield at certain locations in the field leads to a different marginal income. Beside the ecological aspect, these are the two economic reasons for using site-specific fungicide strategies within a field. Under European conditions, the finite fungicide application in winter wheat is often done between flag leaf stage and flowering. Because the upper three leaves and the ear have to be protected against different diseases, broad-band fungicides are commonly used.

With ear emergence, most population parameters of cereals, such as stems per m², plant height or crop coverage, do no longer grow but essentially remain constant. Small-scale differences in plant habitués are more obvious in later growth-stages than in earlier ones. Because of the high incidence of site specific differentiation of plant mass and the high costs of broad-band fungicides, the potential for optimising application rates of site-specific fungicide treatment is the highest at this late timing.

MATERIAL AND METHODS

Nitrogen Application

The sensor was tested in 2000 and 2001 for real-time 3rd nitrogen application in winter wheat in three fields at growth stage BBCH 55....65. On the site-specific treatment the amount of fertiliser (CAN, 27 % Nitrogen) was given in the range from 25 kg ha⁻¹ at minimum plant mass to 250 kg ha⁻¹ at maximum plant mass. This application rate is based on the rule, that in the parts of field with dry stress (low plant mass) the fertiliser can not be absorbed by the roots of the plants. The expected effects were to reduce the costs for fertiliser and to prevent nitrogen leaching without lost of grain quality. To indicate the effects of site specific nitrogen fertilising farm scale stripe trials were arranged with 3 to 4

replications. Based on measurements with the hand held Hydro N-tester the application rate was determined for the plots with the uniform nitrogen fertilisation.

For yield measurements both a weigh-bridge and the yield monitors in combine harvesters (New Holland) were used. For yield comparison two stripes with full working width of combine harvester in the center of each stripe were harvested. Samples were taken by hand to estimate the influence of site specific fertilising on the quality of grain in points with different levels of fertilising. The quality parameters (crude protein, protein quality, falling number, thousand kernel mass) were investigated in a special lab.

For the site specific fertilisation treatment, the pendulum-meter was mounted in front of a Case tractor. In combination with a fertiliser spreader (Amazone ZAM MAX-tronic), a modified LBS board computer (agrocom. ACT) and job calculator (Mueller-Electronic) the sensor was used for site specific nitrogen application on the winter wheat field (Figure 4).

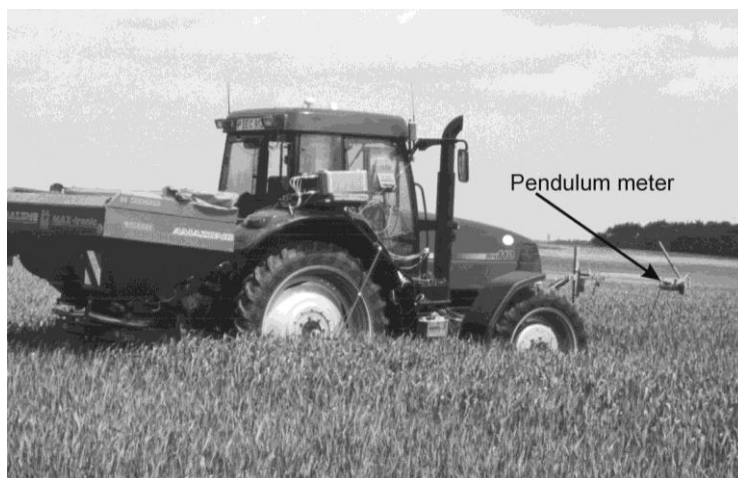

Figure 4. Equipment for site specific nitrogen fertilising

Fungicide Application

Field trials 2000 and 2001 for site specific fungicide application under practical conditions were made within commercially grown fields of winter wheat. A visual assessment by walking through the tramlines took place before spraying (2000: beginning of ear emergence, 2001: end of ear emergence). According to the visual differences in the growth habitus sampling points were selected. The position was recorded by a Global Positioning System. Plant surface was determined on the 17th of May 2000 and 5th of June 2001 using a hand-held optical sensor (2000: LAI 2000®, 2001: SunScan®). The instruments calculate the foliage amount which corresponds to the leaf area index (LAI). The index is dimensionless, but can be considered as square meter foliage area per square meter ground area. A detailed description was given among others by Welles and Norman (1991) for the LAI 2000® and by Anonym (1999) for the SunScan®. Regression analyses

were done for analysing the relationship between LAI and deviation angle of pendulum-meter at the sampling points for calibration. According to this relationship the site specific control of the sprayer was done.

In 2000 each second tram line a uniform application was performed with 1 l ha⁻¹ JuwelTop® in 300 l ha⁻¹ water on 17th of May at beginning of ear emergence (BBCH 51).

In every second tramline of the field the tractor - pendulum -sprayer-combi-nation did the site specific application according to the deviation angle of the pendulum-meter (Figure 5). So the treatment plots were located in alternation. This was done with 3 replications.



Figure 5. *Field sprayer with pendulum-meter*

In 2001 a hole field was sprayed site specifically with 1,2 l ha⁻¹ Caramba® in 300 l ha⁻¹ water on 6th of June at end of ear emergence (BBCH 59).

Disease assessment were done at milk ripeness (BBCH 75) in both years according to the generally described methods. Two stripes per plot were harvested on 4th of August 2000 by a combine harvester (New Holland) with a yield logger. A mean value of the yield measurements was calculated. For purpose of yield comparison the relative yield level (quotient yield of site specific / yield of uniform treatment) were calculated between adjacent yield values. A frequency plot was used to analyse the frequency distribution of the relative yield between the two treatments in 2000.

RESULTS

Nitrogen Application

In 2000 the mean amount of the four site specific fertilised plots was 178 kg ha⁻¹ CAN and for the uniform plots 197 kg ha⁻¹ CAN. In 2001 195 kg ha⁻¹ CAN in the site specific and 243 kg ha⁻¹ CAN in the uniform plots was fertilised. This means, that as the result of pendulum-meter supported application 19 to 48 kg ha⁻¹ CAN fertiliser was saved in the site specific fertilised plots (Table 1).

Table 1. Influence of site specific nitrogen fertilising (3rd application) with pendulum sensor on nitrogen amount and yield

	Unit	Year 2000		Year 2001	
		variable	uniform	variable	uniform
Test area	ha	13.2	13.2	32.4	32.8
Mean CAN	kg ha ⁻¹	178	197	195	243
Yield ¹⁾	dt ha ⁻¹	27.6	26.5	82.5	81.4
Yield difference	dt ha ⁻¹	+1.1	-1.1	+1.1	-1.1
Fertiliser difference	kg ha ⁻¹	- 19	+ 19	- 48	+ 48
N- reduction	%	- 9.7	+ 9.7	- 19.8	+ 19.8
N- efficiency ²⁾	kg kg ⁻¹	16	15	46	43

Stripe plot trial: winter wheat, variety: Batis and Aristos, fertilisation date: 25th of May 2000 and 13th of June 2001, location: Niedergörsdorf/Fläming ¹⁾ related to 14 % moisture ²⁾ kg corn per kg nitrogen

This fertiliser reduction of about 10 – 20 % results from the distribution of fertilising rate. The frequency distribution shows that in some field parts with high plant mass the fertiliser rate was up to 250 kg ha⁻¹. That means the site specific rate was higher than the uniform rate. On the other hand there were a lot of parts with a low level of plant mass and accordingly with a reduced fertilising rate. The reduced fertiliser rate did not effect lower yields. In the centre of the site specific fertilised plots in both years 1.1 dt ha⁻¹ more grain was harvested (Table 1). In spite of different fertilising rates from 7 to 68 kg N ha⁻¹ the grain quality was nearby equivalent in all 50 samples (Table 2). In crude protein, protein quality and falling number the values are slightly higher for low fertilisation levels. For site specific nitrogen fertilisation this tendency is very important because lower grain quality from reduced fertilisation rate would be a serious problem. Only the mass of thousand kernels was reduced in the poor parts of field.

Table 2. Influence of site specific nitrogen fertilising (3rd application) on grain quality

Year	Nitrogen amount kg/ha	Sampling points	Grain quality			
			Crude-protein %	Protein-quality ml	Falling-number s	TKM ¹⁾ g
2000	54 - 68	10	12.9	37	237	41.9
	41 - 53	8	13.2	39	241	41.2
	27 - 40	5	13.3	38	265	36.9
	7 - 26	5	13.4	40	280	36.9
uniform	53	20	13.9	50	253	35.1
2001	54 - 68	5	13.4	57	294	53.3
	41 - 53	7	13.7	58	319	52.8
	27 - 40	3	13.3	53	291	51.2
	7 - 26	7	15.1	61	352	49.4
uniform	68	15	14.3	58	327	50.1

(Stripe plot trail: winter wheat, variety: Batis und Aristos, location: Niedergörsdorf/Fläming, 2000 and 2001) ¹⁾ thousand kernel mass

Fungicide Application

Quadratic polynomials were found as function characterising the relationship between LAI and deviation angle at the sampling points. So the LAI of the winter wheat fields could be estimated site specifically by the deviation angle of the pendulum-meter. In the 3 site specific plots 2000 an application rate of 260, 265 and 270 l ha⁻¹ was applied. That means savings in average of 10...15 % of the spray mixture in comparison to the uniform treatment. In 2001 21.4 ha as hole area of the winter wheat field was treated site-specifically. The mean application rate was around 225 l ha⁻¹. Consequently 25 % of the application rate was saved compared with the conventional uniform application rate (300 l ha⁻¹). In the areas of low application rates as well as in the areas with maximum application rate there was a very low occurrence of leave and ear diseases at stage milk ripeness.

In 2000 a site-specifically yield reduction as well as a yield increase were obtained. The 210 relative yield levels reached from 0.75 to 1.63 (Figure 5). But in average there was nearly the same yield in the uniform and site specific plots (median of the relative yield level: 1.01).

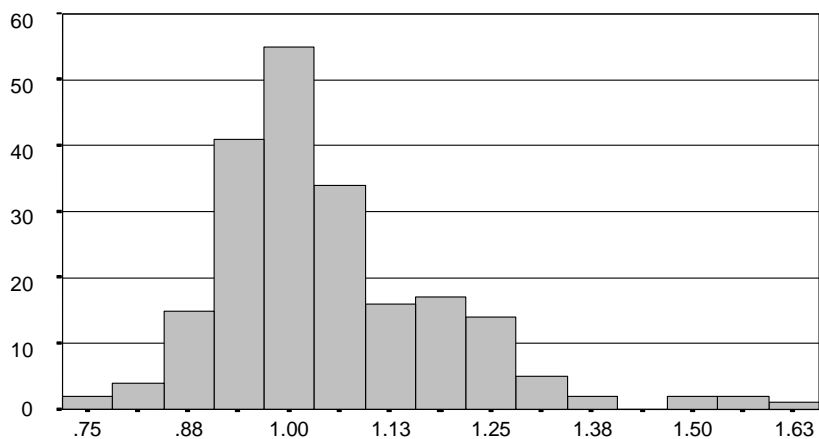

Figure 6. Frequency plot of the site specific relative yield levels (n=210)

CONCLUSIONS

Mechanical sensor pendulum-meter is suitable for indirect measurement of grown plant mass in standing plant populations. Because of this feature it can be used for site specific nitrogen application after BBCH 40 and for site specific fungicide and growth regulator after growth stage BBCH 35 (shooting). The method is especially profitable for late applications when moisture is the growth limiting factor mainly. Under these conditions for instance the fertilising rate can be reduced in poor parts of a field. This saves money for the farmer and reduces the pollution of ground water. The presented results are derived from two year of investigations with different weather conditions in the growth period. For sure validation further test under different soil and weather conditions in the next years are planned.

ACKNOWLEDGEMENTS

Particular thanks for the work in preparing, implementing and evaluating the tests go to the management team of “Nuthequelle GmbH, Niedergörsdorf” and the ATB staff members R. Adamek, U. Frank and H. Schmidt.

This study was additional funded by the ministry BMBF of Germany.

REFERENCES

1. ANONYM (1999) SunScan User Manual, Delta-T Devices, Cambridge
2. EHLERT, D. (2000) Pflanzenmasseerfassung mit mechanischen Sensoren, In: *Proceedings Tagung Landtechnik 2000*, p. 289-294

3. GÜNTHER, H., DAHN, H.G., LÜDEKER, W. (1999) Laser-induced-fluorescences new method for precision farming, In: *Proceedings "Sensorsysteme im Precision Farming"*, Universität Rostock, p 133-144
4. MARQUERING, J., REUSCH, S. (1997) Online-Düngung: Sensor und Ausbringtechnik für eine teilflächenspezifische Stickstoffdüngung, *VDI Berichte 1356*, Düsseldorf, p. 93-96
5. SCHWAIBERGER, R. (2001) "Hydro N-Sensorsysteme im praktischen Einsatz-Satus Quo 2001, In *Proceedings "Tagung Landtechnik 2001"*, p 297-302
6. WELLES J.M., NORMAN J.M. (1991) Instrument for indirect measurement of canopy architecture. *Agronomy Journal* 83, p. 818-825



MASSFLOW-CONTROL ON HYDRAULICALLY DRIVEN DISC-SPREADERS

HORST HESSE, GERHARD KEUPER*

Ingenieurbüro für Hydraulik

Stuttgart, Germany

*Robert Bosch GmbH

Stuttgart, Germany

SUMMARY

The following statements give a brief summary of the benefits of this new mass-flow control-system for disc-spreaders:

- *high precision closed-loop massflow control*
- *no need of preadjusting at the farm*
- *individual mass-flow control for each disc*
- *easy boundary fertilizing*
- *quick reaction after changing set-values*
- *area-specific fertilizing with high precision*
- *contribution to money saving*
- *help to protect environment*
- *"Precision Farming" with low investment-cost.*

INTRODUCTION

Mineral fertilizer is one of the most expensive production-material in modern agriculture. It has even a very strong influence on the environment especially on the ground-water. That means there is a need for a precise measuring of the amount of fertilizer, which is brought out on the field. The same is true for salt-spreaders on roads in the wintertime. Today technical solutions are used, which do not have a real mass-flow measuring-solution and work without feedback.

With this open loop systems the adjusted mass-flow has great variations and cannot full-fill the today precision-farming requirements. A different solution was developed by Bosch, using an electronic weighing-system for the tractor-hitch. With this system the weight-reduction of the attached spreader can be controlled during fieldwork. This solution was presented last year on this conference. The system described here uses a physical effect which is an inherent relationship on the discs of spreaders.

THE BASIC PHYSICAL RELATIONS

There are different technical solutions for spreader systems, one solution is the disc-spreader, **Figure 1**. These disc-spreaders give us a new possibility for massflow measuring. On a disc of a spreader the torque depends on the mass-flow. **Figure 2** shows a disc and what is physically happening there. If the rotating disc would be free of friction and rotates with constant revolution there would be a simple and clear linear relation between the massflow and the torque of the disc.



Disc Spreader for Mineral-Fertilizer

IB/HY

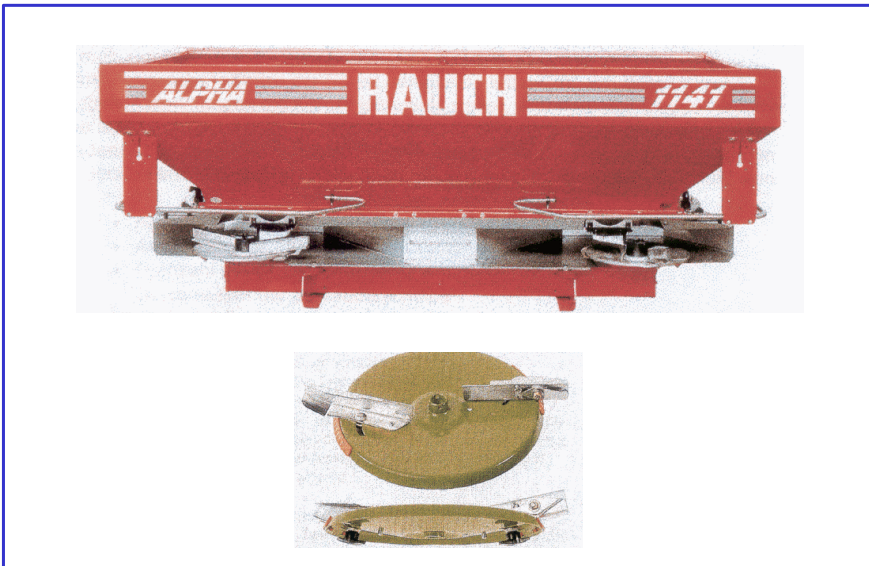

Figure 1: Two-disc fertilizer-spreader

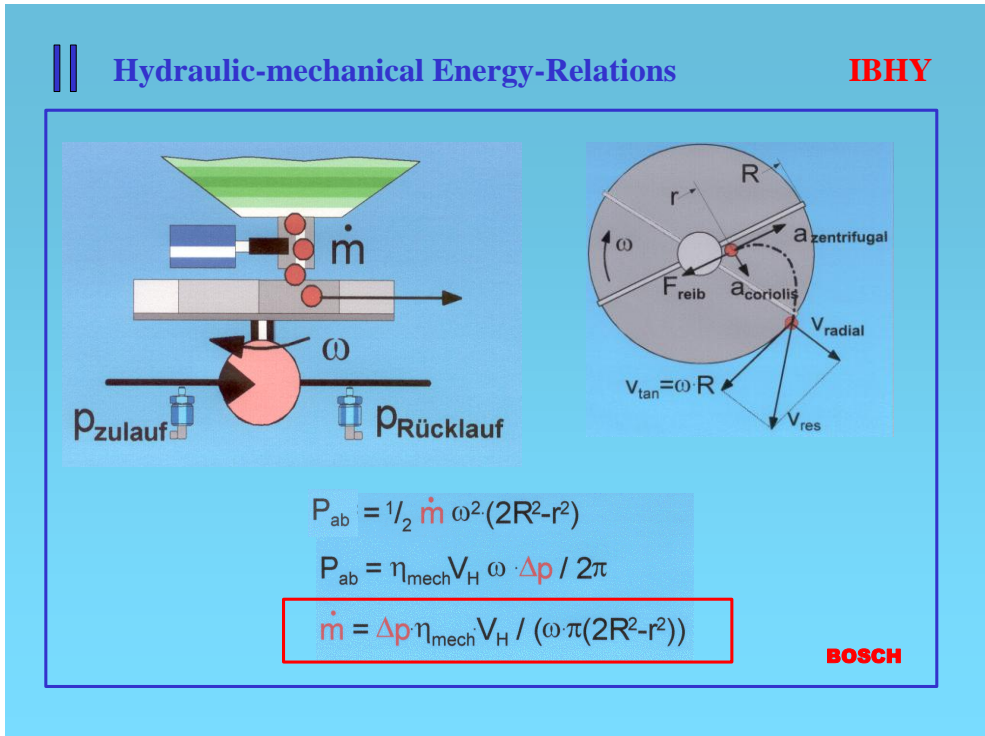

Figure 2: Physical processes on a disc

The energy which is fed in the discs-drive must be equal to the kinetic energy of the spread fertilizer. If the discs is driven hydraulically the theoretical hydraulic power is:

$$P = Q \cdot \Delta p$$

The kinetic power of the fertilizer must be:

$$P = 0.5 \cdot m \cdot v^2$$

The result is that the pressure-drop on the hydraulic motor must be proportional to the massflow:

$$\Delta p \approx m$$

Figure 3 shows the calculated theoretical, frictionfree relationship of the pressure-drop and the massflow for different revolutions of the disc.

|| Theoretical Relation Massflow-Pressure-Drop

IB/HY

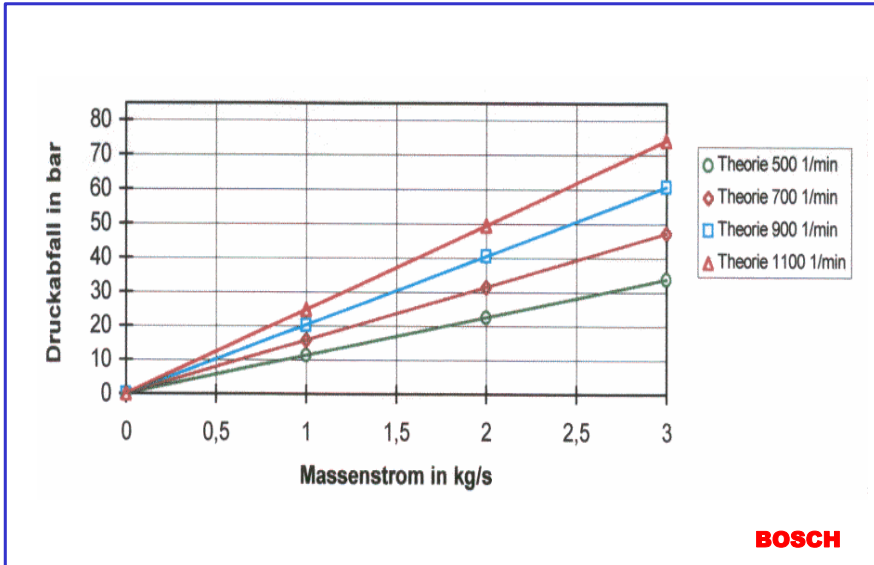

Figure 3: Theoretical relation between mass-flow and pressure-drop

In reality this systems are not free from friction. There are two main frictional influences:

- friction in the hydraulic motor
- ventilator losses of the disc

Under real conditions when the disc is driven with **constant revolution** both influences are constant. That means the influence of friction and ventilator losses can be measured and eliminated.

THE MOST IMPORTANT RESULTS

This was investigated with a system which is shows in **Figure 4**. With two pressure-sensors the input- and the output-pressure of the hydraulic-motor, which is driving the disc is measured.

Figure 5 shows the relation between the pressure-drop Δp and the revolution of the disc with zero massflow.

The Differential Pressure-Measuring

IB/HY

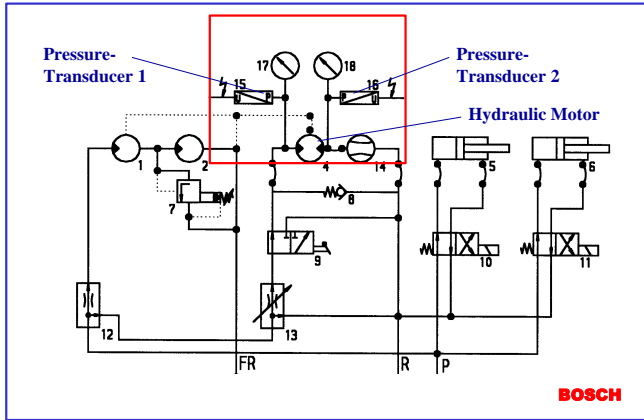

Figure 4: The measuring of the differential-pressure

Pressure-Drop with Zero Massflow

IB/HY

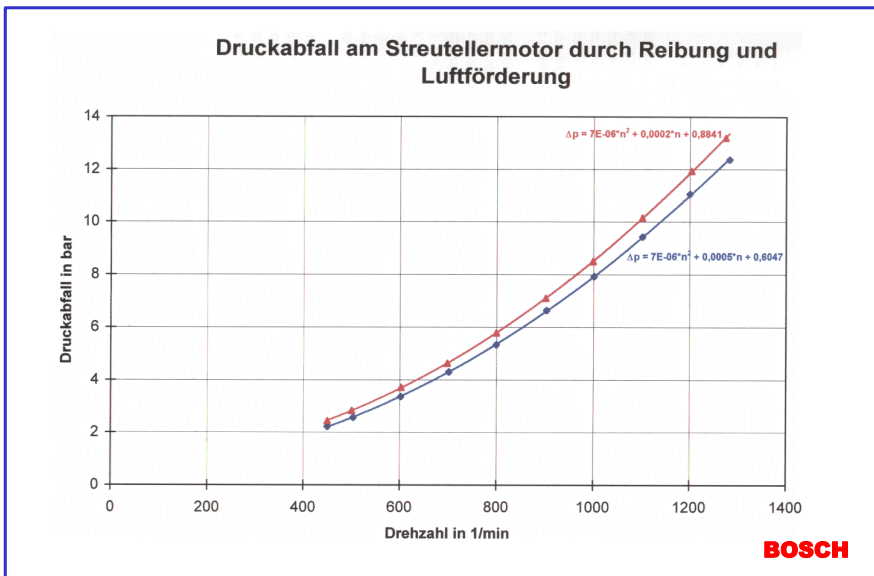

Figure 5: Pressure-drop with zero mass-flow

From this curve for each value of the disc-revolution the “friction-loss- Δp ” can be estimated and used for the electronically calculated real “mass-flow- Δp ”. **Figure 6** shows the measured relation between Δp and mass-flow for different disc-revolutions and different material. The most important results are the linear relation between mass-flow and pressure-drop and its independence from the material structure.

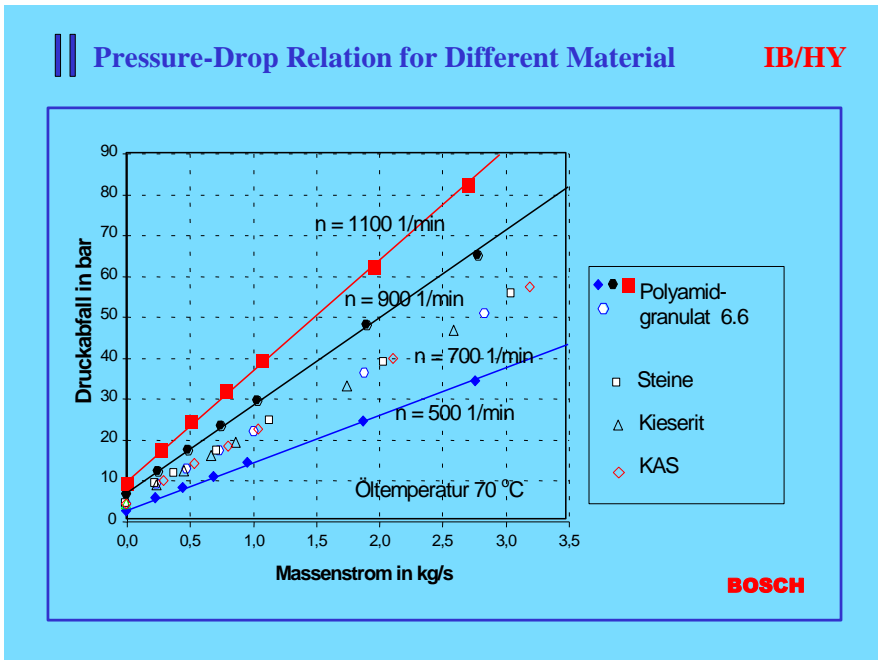

Figure 6: Measured relation for different materials

Figure 7 shows the relation with real fertilizer. The zero-offset can easily be calculated by measuring the pressure-drop with zero mass-flow.

An important question is the precision of this closed loop mass-flow control. In Germany the Deutsche Landwirtschafts-Gesellschaft **DLG** is the authorized institution for agricultural machinery testing. **Figure 8** shows the test results of the DLG - Prüfstelle, which were measured in a testshop.

Measured Relation Massflow - Pressure-Drop

IB/HY

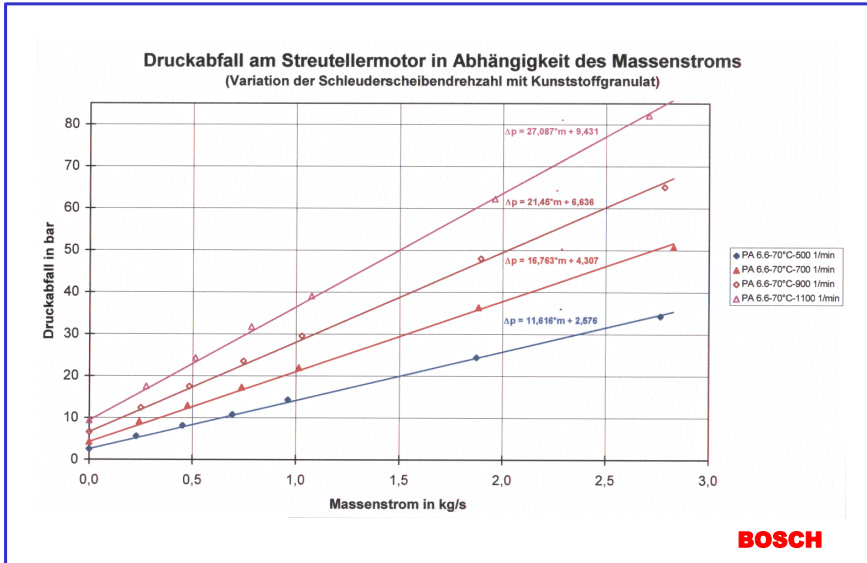

Figure 7: Massflow and pressure-drop with fertilizer

Tabelle 1: Automatisches Abdrehen nach Handbuch

Düngertyp / Beabsichtigte Ausbringung [kg/ha]	beabsichtigter Massenstrom (Soll) [kg/min]	Mittlerer tatsächlicher Massenstrom (Ist)		Soll – Ist Abweichung [%]
		[kg/min]	[kg/ha]	
A / 300	144	142,4	296,7	- 1,1
B / 163	78,24	77,3	161,0	- 1,2
C / 357	171,36	167,5	349,0	- 2,3

Arbeitsbreite: 24 m, 12 km/h

Figure 8: Test-results of the DLG

Under real field conditions this precision will not be achieved, but the absolute failure will be lower than 5 % of the desired value. **Figure 9** shows the principle of the width- and mass-flow control system and **Figure 10** the components for a tractor connected spreader.

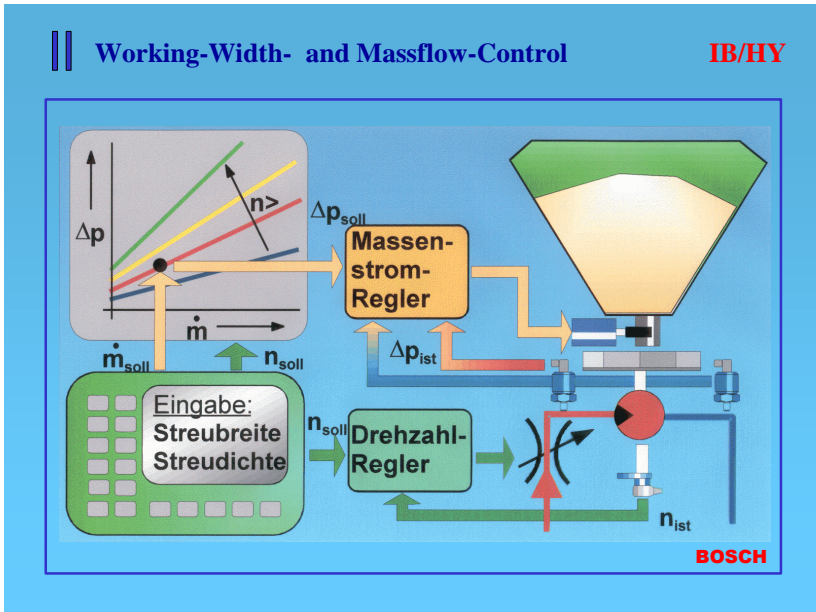

Figure 9: Principle of working-width and mass-flow control

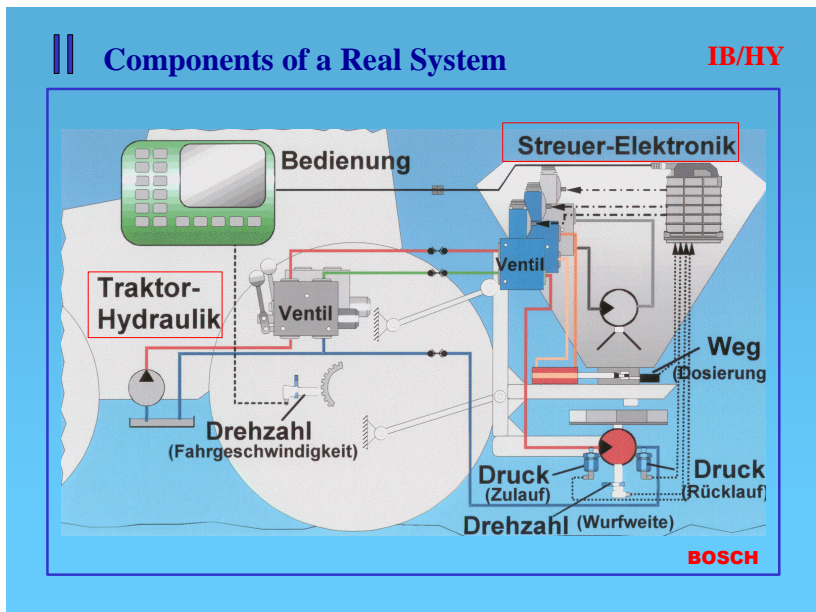
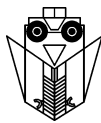

Figure 10: Components of a tractor attached control-system



COMPARISON OF SPINNING DISC AND OSCILLATING SPOUT FERTILIZER SPREADERS PERFORMANCE

TONE PLOJ, BOGOMIR MURŠEC

University of Maribor
Faculty of Agriculture
Maribor, Slovenia

SUMMARY

The paper demonstrates how different levels of shaft revolutions affect the performance of spinning single-disc and oscillating spout fertilizer spreaders widely used by Slovenian farmers. Tests have been conducted on a spinning single-disc spreader manufactured by the Italian company AGREX, and on a oscillating spout fertilizer spreaders manufactured by the Slovenian company CREINA from Kranj. To establish the impact of different revolution levels on the transverse spread - dispersion, spread width and flow of a fertilizer, both types of fertilizer spreaders have been submitted to testing at different RPM levels of the tractor drive shaft: at 290 RPM, 410 RPM, and 540 RPM. It has been established that the different RPM levels have stronger impact on the oscillating spout spreader than on the spinning single-disc fertilizer spreader. The oscillating spout spreader performance at the rated speed has proved better than that of the spinning single-disc fertilizer spreader.

Key words: mineral fertilizer spreader, spinning disc spreader, oscillating spout spreader, transverse spread - dispersion, spread width

INTRODUCTION

Fertilization means adding substances to improve crop productivity [9]. Recently, the use of mineral fertilizers has gone up considerably.

There are two types of fertilization: elementary fertilization and additional fertilization [5].

Mineral fertilizers have been extensively used over the years (Table 1).

The fertilization has been done without any prior soil analysis required for determining the content of individual nutrients in the soil.

Table 1: Trend in use of nutrients over the last years [1]

	1990	1995	1996	1997	1998	1999
Use (kg/ha)	183	354	360	383	411	392
N (t)	19433	27112	26657	27764	29282	29682
P ₂ O ₅ (t)	9906	15148	14658	13770	15602	16867
K ₂ O (t)	10359	18277	17586	17283	18610	20508

Such practice proved bad as it affected the soil structure, damaged plants and washed surplus nutrients not utilized by plants into the ground water, which is unacceptable from the ecological and economic point of view.

We have reached the stage, when the nutrient input must be limited, and fertilizers used cautiously and in appropriate quantities. It is necessary to make soil analyses and prepare fertilization plans thereby taking into consideration the expected crop and through vegetation utilized nutrients.

Fertilizers may be applied manually or by fertilizer spreaders of various types [8].

Modern mineral fertilizer spreaders feature electronic regulation [2]. It is necessary that a fertilizer is accurately distributed in both transverse and longitudinal directions (directions of forward travel), and that a prescribed dosage is achieved.

Present-day mineral fertilizer spreaders are designed to cover in one pass as large working area as possible.

SPINNING DISC FERTILIZER SPREADERS

Spinning disc spreaders apply fertilizers by means of a (quickly) spinning disc with a 50 cm diameter and the circumferential velocity from 12 to 20 m/sec. Due to the centrifugal force the spinning disc spreaders throw the material in a curving fan-type pattern over a distance to the right, front, and to the left (within the range of 120° to 180°), with the swath spread from 6 to 18 m with spinning single-disc spreaders. Spinning twin-disc spreaders may reach the swath spread up to 36 m in one pass. The spinning disc spreader provides the application pattern not symmetrically behind the machine, and a certain level of skewing is present since the direction of the grain movement deviates from the radial direction.

To achieve more uniform distribution and coverage the use of spreaders with two or four discs has become enhanced [7].

OSCILLATING SPOUT FERTILIZER SPREADERS

Instead of a spinning disc, this type of spreaders is equipped with an oscillating tube (Figure 1). While oscillating, the tube in a way imitates manual spreading of the fertilizer. Nowadays, there are models available that achieve the swath width up to 24 m.

At each swing the centrifugal force is interrupted and changes the direction of movement. The result is a more uniform distribution of the fertilizer than with the spreaders furnished with spinning single-disc without interruption in one direction only, and throwing in this direction larger quantity of the fertilizer. The fertilizer does not get crushed, which due to too high circumferential velocity of the mixer is not the case with the standard spinning disc spreaders [7].

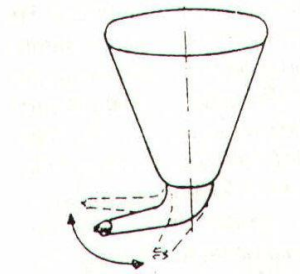

Figure 1: Oscillating spout fertilizer spreader

SPREADERS TESTING

We have tested the spinning single-disc spreader manufactured by AGREX, and the oscillating spout spreader of the Slovenian make. Both spreaders were equipped with a 400 l hopper; the oscillating spout spreader was furnished with the units made by the well-known French company VICON [6]. The spreaders were tested at different RPM levels of the tractor drive shaft (at 290 RPM, 410 RPM and 540 RPM) to establish the impact on the transverse spread - dispersion, spread width and flow of the fertilizer.

For this purpose we have used 3 m long and 1,1 m wide Eternit corrugated plates, which were laid one beside the other, with corrugations marked from 0 to 40 (the corrugation number increasing with the distance). As the test was performed with the tractor in motion, the plates were placed in a way, which allows that the left tractor wheel was driving very close to the first plate, and that the fertilizer was applied to the left.

Since the driving at the edge of the plates could be repeated at the same speed, only the levels of the shaft RPM changed. We have chosen the travelling speed of 1 km/h to allow as much fertilizer as possible to drop on the plates.

Both spreaders operated at the medium setting (about half open). The flow of the spinning disc spreader was set to 5 of 10 possible settings (0 - 10), with the bolt screwed to

a desired mark ensuring always the same setting (opening) and preventing the shutoff lever to be too open.

The flow of the oscillating spout spreader was set to 24. Other possible settings are 12, 18, 24, 30, 36, 42, 48, 54, and 60.

SPINNING DISC SPREADER TESTING

To perform the testing we have used the AGREX model XA 400 (Figure 2) with single-disc featuring 4 blades with variable angles (5 possible settings). The position 3 was chosen. The bottom of the hopper is fitted a mixer and the shutoff featuring two openings. The material can be applied either only to the left or only to the right depending on the openings chosen. The RPM levels and the direction of the blender rotation are always that of the impeller-type disk. The spreader weighed 50 kg and the 24 kW tractor was required to start the spreader.



Figure 2: AGREX fertilizer spreader coupled to tractor

Spinning disc spreader transverse spread - dispersion measurement

To establish transverse spread - dispersion of the spinning disc spreader, we have used Eternit corrugated plates (300 x 110 cm) laid one beside the other in a way that only application pattern to the left was possible.

To establish the spreading performance, the tractor at a constant speed of 1 km/h and at certain PTO revolutions passed the plates. The fertilizer that dropped on the plates gathered in the corrugations. When the tractor was far enough that the fertilizer no longer dropped on the plates, it stopped and the drive shaft was disconnected.

The procedure was repeated three times, at 290 RPM, at 410 RPM, and at 540 RPM, with the spreader disc 45 cm above the ground. The test was performed with KAN 27 % N small-grained mineral fertilizer, manufactured by Petrokemija Kutina. Each time the test was repeated, the fertilizer was swept from the corrugations, and each pattern from a single corrugation was weighed on an accurate scale onto the gram exactly. The corrugations were marked from 0 to 40, the corrugation 0 being at the tractor wheel. The testing was performed in a covered warehouse to exclude any influence of wind.

Spinning disc spreader spread width measurement

A measuring tape was used to measure the spread width during the operation of the tractor standing still. Two men, one at each end, supervised the procedure, which was repeated three times at different shaft RPM levels (Table 2). With the performed measurement the maximum spread width was established.

Table 2: Spinning disc spreader spread width values obtained

	290 RPM	410 RPM	540 RPM
1	13,2 m	14,6 m	15,3 m
2	13,1 m	14,6 m	15,4 m
3	13,0 m	14,4 m	15,3 m
AVERAGE	13,1 m	14,5 m	15,3 m

Spinning disc spreader flow measurement

The measurement was taken with the spreader covered from all sides with plastic wrap. The tractor was set at certain RPM levels, the shutoff lever was opened, and the stopwatch activated. After two minutes we closed the shutoff. The fertilizer collected in the wrap was put in a vessel and weighed.

We repeated the procedure three times always adjusting the spreader to the setting 5 (Table 3). The spreader fitted with an attachment screw to determine the setting (0 - 10), allowed us to always select the same setting.

The hopper contained 50 kg of the fertilizer. After each repetition, the weighed fertilizer was put back to the hopper so as to obtain each time the starting 50 kg.

Table 3: Spinning disc spreader flow values obtained

	290 RPM	410 RPM	540 RPM
1	20,88 kg	21,76 kg	22,32 kg
2	20,44 kg	21,64 kg	25,56 kg
3	23,0 kg	21,48 kg	23,1 kg
AVERAGE	21,44 kg	21,62 kg	23,66 kg
FLOW kg/min	10,72	10,81	11,83

OSCILLATING SPOUT SPREADER TESTING

To perform the testing we have used the CREINA product featuring a hopper made of synthetic material with the capacity of 400 l (Figure 3). The spreading mechanism made by VICON features three angle settings: 76°, 96°, and 112°. We have chosen the angle of 76°.

A 35 kW tractor drove the spreader. At the bottom of the hopper there is the shutoff with three openings, which allow the material to flow. During the operation the mixer only oscillates from the left to the right. Adjusting the fertilizer flow is done by means of a setting screw spindle opened to the set position with a shutoff lever.



Figure 3: CREINA oscillating spout spreader coupled to tractor

Oscillating spout spreader transverse spread - dispersion measurement

To establish the transverse spread - dispersion we used the same procedure as when establishing the transverse spread - dispersion of the spinning disc spreader. The spreader was set to the same height, with the tube 45 cm above the ground, the flow set to 24, the travelling speed of the tractor at 1 km/h, and with different tractor drive shaft RPM levels. The procedure was repeated three times: at 290 RPM, at 410 RPM, and at 540 RPM. Again the tractor started driving before the plates, the spreader open to allow the fertilizer dropped normally only to the left. When the tractor was far enough that the fertilizer no longer dropped on the plates, we stopped the tractor and the material application. Each repetition was performed under the same conditions.

Oscillating spout spreader spread width measurement

The spread width was measured by using exactly the same procedure as with the spinning disc spreader: with a measuring tape during the operation of the tractor standing still. The procedure was repeated three times, each time at different shaft RPM levels. The obtained values were entered in Table 4.

Table 4: Oscillating spout spreader spread width values obtained

	290 RPM	410 RPM	540 RPM
1	7,5 m	11,0 m	14,6 m
2	7,4 m	11,2 m	14,4 m
3	7,4 m	11,1 m	14,5 m
AVERAGE	7,4 m	11,1 m	14,5 m

Oscillating spout spreader flow measurement

We have used the same procedure as with the spinning disc spreader. The spreader, set to the fixed flow, and with the spindle set to the position 24, was covered from all sides with a plastic wrap. When the tractor was set at certain RPM levels, we opened the shutoff lever and activated the stopwatch. After two minutes we closed the shutoff, and disconnected the drive shaft. The fertilizer collected in the wrap was put in a vessel and weighed. We repeated the procedure three times, each time at different RPM levels (Table 5).

Table 5: Oscillating spout spreader flow values obtained

	290 RPM	410 RPM	540 RPM
1	41,76 kg	45,68 kg	45,96 kg
2	40,1 kg	45,36 kg	47,2 kg
3	40,7 kg	45,56 kg	47,1 kg
AVERAGE	40,8 kg	45,56 kg	46,7 kg
FLOW (kg/min)	20,4	22,78	23,4

TEST RESULTS

The aim of the testing was to find out how different shaft RPM levels would influence the machine performance. We have used two machines widely used by our farmers: a spinning single-disc spreader, and a tractor-portable oscillating spout spreader. Both spreaders feature factory setting of the shaft RPM levels at 540. We wanted to find out whether the performance of the machines would be affected at lower RPM levels.

To ensure the same conditions throughout the testing, the testing was performed on an even concrete surface of a large covered warehouse. The tractor used was fitted with a shaft revolution counter.

The latter showed the revolutions at a particular moment, which allowed us to ensure the exact number of revolutions during each repetition.

Spinning disc spreader

When examining the machine, we first established that its design has become obsolete. A spinning single-disc spreader is a very old model, yet easy to use and maintain. The gear wheel, protected and placed in a housing, is permanently greased and does not require any special maintenance.

The machine metal parts require a lot of cleaning to avoid the problem of rusting of the parts of which the protection layer has been damaged.

The trial spreading showed a strong distribution of the mineral fertilizer in all directions. When conducting a transverse test, the spread pattern was uneven and more fertilizer was applied towards the center and less at the edges.

The calculation of the mean weight of the mineral fertilizer in the corrugations of the working area (that is smaller than the spread width), and the comparison of this weight to the weight of the fertilizer found in the corrugations, indicate as follows: at 290 RPM the far edges received much less fertilizer than the center area. The most uniform pattern with the least skewing was achieved at 410 RPM. At 540 RPM the fertilizer was dispersed in a big curve with the fertilizer turning into dust due to the impact power of the blades.

In the center area, there was a major surplus of the fertilizer noted with regard to the mean value (110 %).

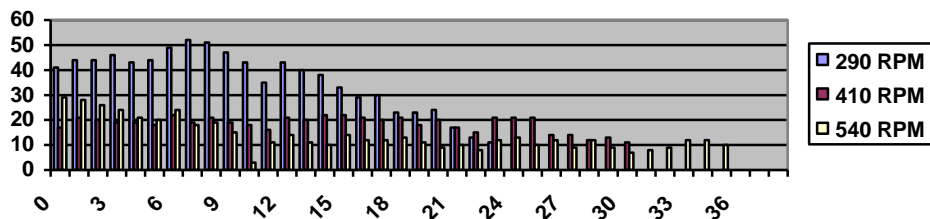

Diagram 1: Fertilizer spread pattern at different RPM levels

When measuring the spread width, we expected the width to increase at higher RPM levels. Although the test confirmed our expectations, it was interesting to find out that the spread width actually only to a smaller extent depends on the change of RPM levels.

At 290 RPM, the spread width was reduced only by 14 % although the revolutions were reduced by 46 % if compared to 540 RPM, and at 410 RPM the spread width was reduced only by 5,2 % although the revolutions were reduced by 24 % if compared to 540 RPM.

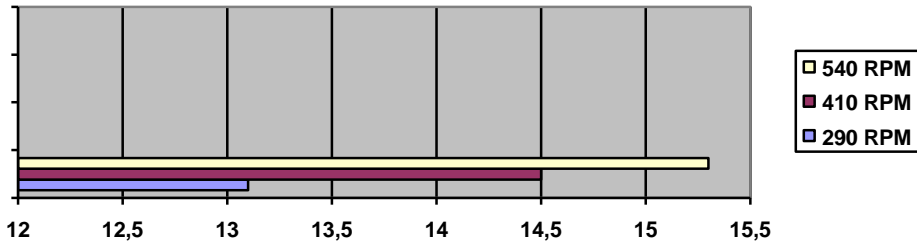

Diagram 2: Spinning disc spreader spread width at different RPM levels

The findings of the flow measurement were very similar. At 290 RPM, the flow was reduced by only 9,4 %, and by 8,6 % at 410 RPM. It can therefore be concluded that the flow does not much depend on different RPM levels.

Oscillating spout spreader

The design of this type of spreader has improved but requires more complex maintenance. The oscillation mechanism being under constant load needs regular checking and greasing. The mechanism, enabling the tube to oscillate from the left to the right during the machine operation, is submitted to the forces generated by the constant acceleration and deceleration from one extreme position to another. Both the hopper and the tube are made of synthetic material and thus independent of corrosion. After each use the oscillation mechanism and the shutoff must be rinsed and blown out by compressed air to prevent rust formation.

At 290 RPM, the spread width measurement showed rather small dispersion, an uneven pattern with the majority of the material applied in the center (if compared to the mean value) and much less at the outermost edges. At 410 RPM, the spreader had a wider distribution pattern, but the uniform coverage was still not achieved. The best results were obtained at 540 RPM, i.e. at prescribed revolutions. There was still a surplus of the material at the center area, which diminished with the distance. The shortage of the material was still noted at the outermost edges.

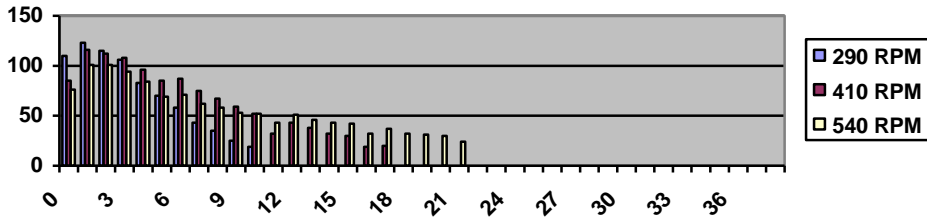

Diagram 3: Left spread pattern width of oscillating spout spreader

The dispersion test demonstrated that the spread pattern quality greatly depends on the number of revolutions, and the measurement of the spread width confirmed that. At 290 RPM, the spread width was reduced only by 49 % although the revolutions were reduced by 46 % if compared to 540 RPM, and at 410 RPM the spread width was reduced only by 23 % although the revolutions were reduced by 24 % if compared to 540 RPM.

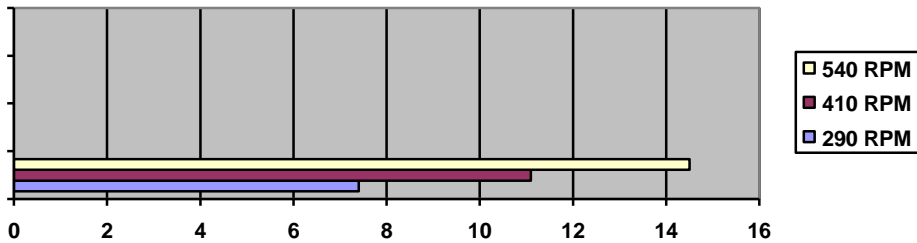

Diagram 4: Oscillating spout spreader spread width

As for the flow, the test results obtained showed that at 290 RPM the flow was reduced by 12,8 %, whereas at 410 RPM it was reduced only by 2,6 %.

CONCLUSIONS

In this article we were dealing with mineral fertilizer spreaders, the area which has become more and more interesting from the viewpoints of economy and ecology. With the aim to reduce to minimum the environmental load and cultivation costs, it is vital to ensure a uniform coverage for which special knowledge and machines are required.

The tests, made on the AGREX spinning single-disc fertilizer spreader and CREINA oscillating spout fertilizer spreader, have demonstrated the impact of different RPM levels on the performance of the spreaders. To establish the impact, three parameters were chosen: transverse spread, spread width and flow.

The results obtained indicated that different RPM levels had stronger impact on the oscillating spout fertilizer spreader. The performance of the oscillating spout fertilizer spreader at rated revolutions was better than that of the spinning single-disc fertilizer spreader.

The development of oscillating spout fertilizer spreader along with the technical solutions has increased the fodder production even up to 300 %. In the context of the biomass pedological and nutrient requirements, these spreaders allow additional fertilization in very small but adequate amounts throughout the year. And this is also the reason why cultivation of grasses and crops on relatively small areas has been tripled.

REFERENCES

1. BANOVEC T. in sodelavci: (2000) Statistični letopis RS 2000; Ljubljana: 294.
2. BRČIĆ J.: (1981) Mehanizacija u biljnoj proizvodnji, Zagreb: 75 - 85.
3. GLIGORIJE P.: (1976) Poznavanje i korištenje poljoprivrednih mašina, Beograd: 123 - 132.
4. JENČIČ R.: (1982) Kmetijski stroji, Ljubljana: 74 – 78.
5. KLOBUČAR B., GRAČAN R., TODORIĆ I.: (1982) Splošno poljedelstvo, Ljubljana: 3 - 6, 109 - 121.
6. KREPFL F.: (2001) Vpliv spremembe vrtljajev na delovanje centrifugalnega in nihalnega trosilnika, Diplomsko delo, Maribor.
7. MRHAR M.: (1997) Kmetijski stroji in naprave, ČZD Kmečki glas: 94.
8. NOVAK M.: (1990) Razsipalniki za gnojila, Ljubljana.
9. ŠESTIĆ S.: (1985) Gnojidba pšenice i kukuruza, INA.



VARIABLE RATE OF MINERAL FERTILIZERS APPLICATION OPTIMIZATION

GENNADI I. LITCHMAN, VASSILI M. DRINCHA*

Laboratory of Mechanization of Fertilizers Application
All-Russian Institute of Mechanization of Agriculture
Moscow, Russia

*Russian Academy of Agricultural Sciences
Moscow, Russia;

SUMMARY

The use of technology to spatially vary the application rate of fertilizer within a field may help to increase effectiveness of fertilizers and considerably reduce pollution of environment. This paper develops a method of substantiating the optimum application rates of fertilizer within a field. Method will help to evaluate whether managing nutrients within a field is cost effective or not. We used a grid that divides a field with area S into n small, more uniform plots, with area S_1, S_2, \dots, S_n , respectively. It was assumed that for every plot relations among yield response, soil test levels and applied fertilizer are given. These relations can be described by nonlinear (quadratic) functions. Optimal rate of fertilizer application for every plot was found by using the Lagrangian method. Proposed algorithm would be most useful in determining the optimal rates of fertilizer application in site-specific management for agricultural systems, and may be used for predetermining which parameters may make the greatest contribution to the total yield from the given field.

Key words: yield response, Lagrangian method, optimal rates

INTRODUCTION

It is well known that soil nutrient availability may significantly vary within fields. In spite of that one fertilizer grade is prepared and spread over one or several similar fields. The net result is that some areas within a field receive more nutrients than are required, while in other areas nutrients may remain limiting to crop production. Neither situation is economically or environmentally desirable. Alongside there are variations in soil texture,

color and/or productivity within fields. Soil type variations affect crop production and the amount of nutrients removed from each area of the field.

The use of technology to spatially vary the application rate of fertilizer within a field may help to solve this problem. Thus it is a subject of much current interest to develop a method of substantiating the optimum application rates of fertilizer within a field. This method will help us to evaluate whether managing nutrients within a field is cost effective or not.

METHODS

In the paper a grid that divides a field with area S into n small, more uniform plots, with area S_1, S_2, \dots, S_n , respectively was considered [2]. It was assumed that we have for every plot relations among yield response, soil test levels and applied fertilizer. These relations can be described by nonlinear (quadratic) functions [1].

$$y_i = y_i(D_i + x_i) \quad (1)$$

where: y_i is a yield (productivity) of i -th plot; D_i is an amount of nutrients in the soil available to the crop; x_i is an application rate of fertilizer for i -th plot.

There is a possibility to apply M kg of a particular fertilizer, for which we have functions (1). It is required to find such application rates of fertilizer for every i -th plot x_1, x_2, \dots, x_n , which bring to the following result:

$$\begin{aligned} \sum_{i=1}^{i=n} y_i(D_i + x_i) * S_i \rightarrow \max \\ x_1 + x_2, \dots, + x_n = M \end{aligned} \quad (2)$$

To these equations the environmental or other constraints may be added.

We assume that functions (1) are known

$$y_i = a_{0i} + a_{1i}(D_i + x_i) + a_{2i}(D_i + x_i)^2 \quad (3)$$

Equation (3) is an empirical function, which increases with increase of x_i up to a certain y_{\max} and then decreases. The function has been applied successfully in a number of previous studies.

Further we have considered that field is divided into plots equal in area $S_1 = S_2 = \dots = S_n = 1$ ha. To solve the problem (2), the Lagrangian method was used. For this purpose was introduced an auxiliary function

$$\varphi = \sum_{i=1}^{i=n} y_i(D_i + x_i) + \lambda \sum_{i=1}^{i=n} x_i, \quad (4)$$

where: λ is Lagrangian multiplier.

After having taken first derivative from (4) by x_i and equate it with zero we shall get a system of $n+1$ linear algebraic equations for finding $n+1$ unknowns x_1, x_2, \dots, x_n and λ .

Table

№ of plot	1	2	3	4	5	6	7	8	9	10	Tot
M=800kg											
x_{aver} , kg/ha	80	80	80	80	80	80	80	80	80	80	800
y, cw/ha	15.5	17.3	19.4	21.4	21.4	24.6	23.9	24.9	25.9	26.9	221
x_{opt} , kg/ha	27.6	30.6	34.2	42.8	86.2	63.8	128.7	128.7	128.7	128.7	800
y, cw/ha	14.0	15.4	17.7	19.9	21.7	23.9	26.4	27.4	28.4	29.4.	224

ACKNOWLEDGEMENT

We thank V. Skotnikov and J. Lowenberg-DeBoer who helped this note through discussion and valuable comments on drafts.

REFERENCES

1. BONGIOVANNI R., LOWENBERG-DEBOER J. (1998) "Economics of Variable Rate Lime in Indiana", Precision Agriculture: Proceedings of the 4th International Conference, ASA/CSSA/SSSA, St. Paul, MN, p. 1653-1665, July, 19-22,
2. WOLLENHAUPT, N., C., WOLKOWSKI, R.P. AND REETZ JR., H.F., (1997) Variable rate fertilizer application: update and economics. R.M. Vander Hewel (ed), Information Gathering: Precision Agriculture and Intensive Soil_Sampling. Cenex Land O Lakes, Agronomy Technical Services/Agrisource Laboratories. Inner Grove Heights, MN.



INCREASE OF EFFICIENCY OF SEED SEPARATION IN GRAVITY SEPARATOR

V.M. DRINTCHA, S.A. PAVLOV*

Russian Academy of Agricultural Sciences
Moscow, Russia

*Filial of All Russian Institute of Agricultural Mechanization
Moscow, Russia

SUMMARY

Experiments were conducted to study the opportunity of increase of efficiency of seed separation in gravity separator. A complex of physical characteristics of cereal grain sorted by a gravity separator has been studied. The attributes (physical properties of seed) of gravity separation in fluidized bed were found by using the mathematical method of pattern recognition. The sorted fraction differed significantly in seed specific gravity as well as in seed size. No significant differences in seed kinetic coefficient of friction were found. These data were used for development of fractional technologies used for separation of difficult divided grain mixture. The dividing of an initial grain mixture by indented cylinder in two fractions and processing of each fraction on gravity separator enables to increase efficiency of seed separation on 10...15 %. These results were used for development of separation technologies of cereal grain as well as for grass seed mixture. Rational technological and design parameters of gravity separators were substantiated on the basis of carried out results of researches.

Key words: gravity separator, physical properties of seed, fluidized bed.

INTRODUCTION

Gravity separation is a process that utilizes a fluidized bed for cleaning and sorting granular materials. This technique was first used by the mineral industry for ore reclamation and has since been adapted for use in many others areas. Gravity Separator has a wide field of application in the final cleaning of all types of seed for the removal of weed seeds, impurities and seed of low germination, etc. which cannot be satisfactory separated

by air, screen, or indents. The seed industry also utilizes gravity separators to upgrade quality of seed lots by removing diseased, damaged or other undesirable seeds that are somewhat lighter than the remaining good quality seeds. Removal of low quality seed can sometimes permit recovery and sale of a portion of a seed lot which would otherwise not meet quality requirements for seed usage. This practice has become popular in the industry since seed quality standards are normally high.

Because of the inherent nature of the machine and the close separation required, proper adjustment of a gravity separator is difficult and requires a skilled operator. This difficulty is compounded in some high quality seed lots because there often is no discernible visual difference between high and low quality fraction. Since discarding a large portion of a valuable crop is costly, some other rapid means of quality determination must be employed when adjusting the gravity separator for such crops. Test weight (bulk density) is frequently used in the seed industry to distinguish among various quality fractions in gravity separated crops. Low quality seed usually is lower in test weight than good seed. By making test weight measurements at intervals along the discharge, it is easier to determine the correct discard percentage. Experience with soybean separation has shown that only small test weight differences exist between fraction of a typical soybean lot [2]. No information was found in the literature on variation of test weight and other physical properties of cereals seed along the discharge edge of a gravity separator.

Research data pertaining directly to gravity is somewhat limited. Mississippi State University [1] lists three general rules for gravity separation. According to this source, mixtures of seeds of similar size and shape but with different seed densities will be split into fractions of different specific gravity. Seeds with uniform seed density but differing in size can be separated by size. Mixtures containing wide variations in both seed density and size cannot be separated properly.

Some information is available to describe types of separations possible on gravity table for cereals seed. Misra found [4] that the gravity separator also successfully removed splits that were produced during movements of seeds one location to another in a seed conditioning plant. A few reports of research on density characteristics was also found [5].

A better understanding of gravity separator phenomena would aid in operation and machine design. To understand the process by which particles are separated to use this knowledge to develop more effective process of separation, it is necessary to study variable physical properties of seeds in initial and sorted materials on gravity separator.

The objectives of this work were:

- to quantify the variation of basic physical characteristics in fraction of various seedlots sorted by gravity separation;
- to increase efficiency of seed separation in gravity separator.

PROCEDURE

The four types of seeds: oats, field pea, rye and winter wheat were chosen for this experiment. Three replications were used. Replications consisted of the same seed variety obtained from different seed enterprises. Prior to gravity separation, all seed lots were screened and aspirated using a screen cleaner model PC-0.5 (developed in All Russian Institute of Agricultural Mechanization, Moscow) to remove broken seed and foreign material. Seed was then passed through a Petkus (Germany) model K – 293 to remove light components. The gravity separator used for the test was a Voronezh (Russia) model ПСС-2.5 equipped with 1.2 m² deck and an adjustable feed gate. The essential parts of this machine (fig. 1) are a porous deck 1, the oscillation assemblies 2, a fan 3 that forces air through the deck 1, and air control arrangement 4 over the deck 1. No dust hood was provided over the deck, and no attempt to recycle a middling fraction was made. In machine operation, the seed mixture is introduced uniformly at the back of the deck (A), which is inclined downward from back to front, and also upward from the light side to the right side. Material to be sorted on a gravity separator is placed in a thin layer 4 to 20 seeds deep on the deck. Low pressure air forced up through the deck permeates the seed mass and forms a shallow, fluidized bed. The lighter particles tend to float and form a layer at the top of the bed (B), and the heavier particles sink to a bottom layer (D) where they contact the deck. Fraction of intermediates physical properties of seeds (C) assume intermediate positions in the stratification. The oscillation motion of the deck moves the heavier seeds laterally toward the uphill side of the deck. At the same time, the floating, the lighter material moves laterally downhill by gravity. As the seed mixture travels from the feed point to the discharge edge of the deck, a continuous gradation of seeds takes place ranging from the lighter ones at the lower side of the deck, to the heavier ones at the upper side. Simple movable dividers were used to separate various fractions of the material. To assure operating conditions for each lot, all seed discharged from the gravity deck was recycled manually for several minutes after start up to provide time for machine adjustment. Care was taken to provide uniform deck coverage and air velocities over the deck at a capacity of about 2100...2200 kg/h for all lots. Feed rate was kept as constant as possible because even small changes in rate affect result. Experiments were carried out under carefully controlled parameters.

One sample of each seed lot was drawn at the seed inlet to the gravity separator and also at each of seven (six) locations across the discharge edge. All samples weighed about 1 kg and were drawn by hand in a random order.

Physical properties of individual kernels: main dimensions (thickness, width, length), mass, specific gravity, volume, terminal velocity, kinetic frictional coefficient and volume shape factor were determined.

Dimensions of kernels were carefully measured along three perpendicular axes using a micrometer. Each kernel was weighed by an electronic balance capable of reading to 0.0001 g. A specific gravity gradient column containing a mixture of liquid carbon tetrachloride-cyclohexane to determine the density range of individual kernels within given seed samples was used. Seed kernel mass and specific gravity of kernels were used to calculate the volume values of kernels. Terminal velocities were measured by placing kernels in the duct, while the fan discharge was increased until the kernels, seen through the

transparent wall, floated in the central area of the air stream. The samples from each group were tested and each kernel was tested three times. The average values of terminal velocities were recorded. The kinetic frictional coefficients of kernels were determined by using the test unit which include a rotating disk and a stationary sample container with its support shaft [6]. Volume shape factor is a criterion for describing the shape of particles and it was estimated from the following equation [3]:

$$z = \frac{\pi}{6} \left(\frac{d_g}{d_e} \right)^3 \quad (1)$$

where: d_g – geometric diameter, mm; d_e – diameter of equivalent sphere, mm.

The mathematical method of pattern recognition was used for determining of an complex physical properties of seeds in the process of gravity separation.

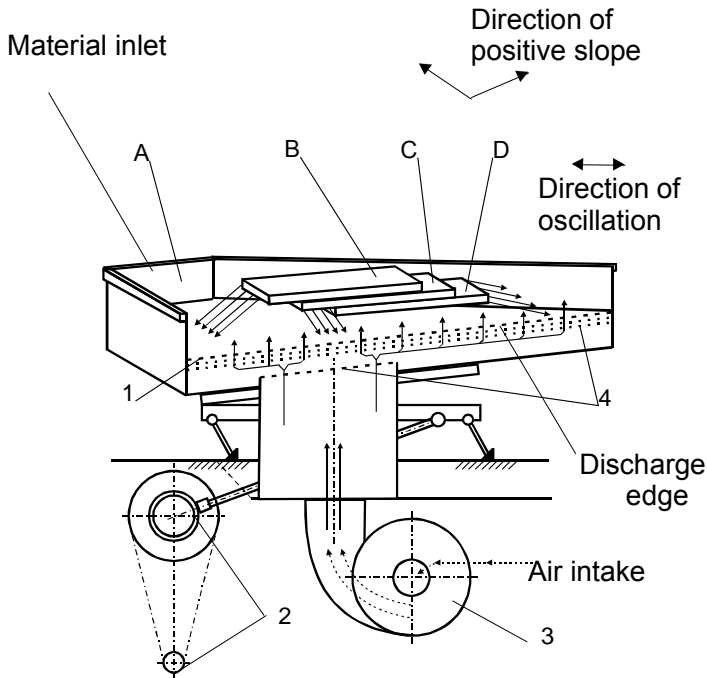

Figure 1. Isometric scheme of gravity separator used for this study

RESULTS AND DISCUSSION

Data were analyzed by using an ANOVA procedure.

Table 1. Effect of sampling location on physical properties of seeds

Location p.c.	Specific gravity, g/cm ³	Mass, g/1000	Volume, cm ³ /1000	Test weight, kg/m ³	Terminal velocity, m/s	Thickness, mm
Oats						
1/11.4 (Heavy)	1.10	41.80	38.00	608	8.00	2.42
2/16.4	1.08	40.73	37.71	596	8.02	2.44
3/22.4	1.04	39.85	38.32	579	7.87	2.41
4/20.7	1.02	36.35	35.64	563	7.59	2.36
5/9.3	0.99	33.90	33.90	536	7.48	2.31
6/15.8	0.90	29.90	33.22	457	6.88	2.21
7/4.0 (Light)	0.89	23.70	26.63	357	6.44	2.07
Initial	1.03	37.00	35.92	555	7.7	2.37
Field pea						
1/8.64 (Heavy)	1.37	204	148.91	781	15.44	6.17
2/24.92	1.37	208	151.82	775	15.34	6.08
3/23.94	1.35	214	158.52	773	15.16	6.11
4/15.55	1.33	200	150.38	768	15.03	6.00
5/10.75	1.32	192.4	145.76	757	14.20	5.90
6/16.20 (Light)	1.28	165.4	129.22	731	13.26	5.87
Initial	1.35	197.4	146.22	770	15.05	6.01
Rye						
1/1.5 (Heavy)	1.32	33.8	25.6	601	8.40	2.41
2/10.8	1.32	30.5	23.11	585	8.22	2.41
3/20.6	1.31	31.1	23.74	554	8.27	2.38
4/16.5	1.30	28.4	21.84	532	8.10	2.35
5/14.4	1.26	23.8	18.89	501	7.73	2.22
6/31.1	1.23	19.4	15.77	483	7.50	2.11
7/4.8 (Light)	1.24	16.7	13.47	409	7.30	2.08
Initial	1.28	25.2	19.69	559	7.90	2.36

Table 1 lists values of physical properties for oats, field pea and rye at each locations. The correct discard percentage for each culture was determined by making test weight measurements at intervals along the discharge edge (the percentage is shown in the first column in denominator and a fraction number in numerator in the first column of table 1). A summary of results for each property considered follows.

Specific gravity across locations, varied significantly ($P \leq 0.5$) over a range from 0.89 to 1.10 g/cm^3 for oats, from 1.28 to 1.37 g/cm^3 for field pea and from 1.24 to 1.32 g/cm^3 for rye. Seed mass varied significantly over a range from 23.70 to 41.80 $\text{g}/1000$ oats seeds, from 197.4 to 214 $\text{g}/1000$ field pea seeds and from 16.7 to 33.8 $\text{g}/1000$ rye seeds. A consistent trend toward lower seed mass in samples closer to the light end (location 6 and 7) was noted, with an average value location 6 and 7 mass 1000 seeds lower than the samples at the heavy end (location 1). The average seed mass at the light end (location 6 and 7) was lower on average 22 per cent than the input samples.

Samples collected from location 6 and 7 were also significantly lower in test weight, terminal velocity and thickness than initial samples (table 1). The significant difference between test weights of the other fraction was found. A very high correlation ($r=0.99$) between seed volume and seed mass was found for all seedlots. For this reason, the same trends discussed for seed mass also hold for seed volume.

Relationships between physical properties of separated seeds and their quantities are very important for all practical purposes. Seed mass can be easily measured in comparison with other seed physical properties. Very high correlation ($r=0.95$) between seed mass and seed specific gravity was found. Therefore the seed mass is a very convenient property for estimating seed sorting on gravity separator. On the basis of experimental data (table 1) the relationships between mass of 1000 seeds and quantities of divided materials were obtained (Fig. 2).

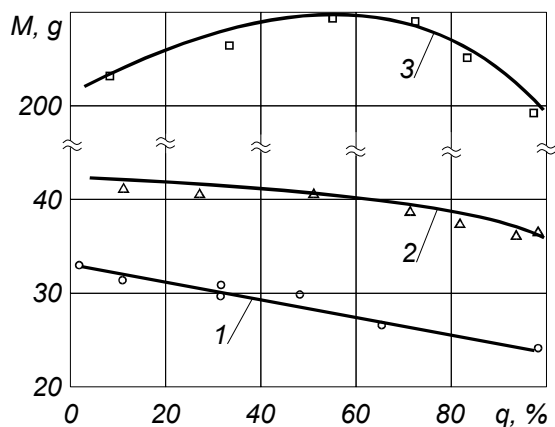

Figure 2. Relation between mass of 1000 seeds and quantities of the sorted materials (from the lower end of discharge edge to its higher end): 1 - rye; 2 - oats; 3 - field pea

The regression equations and their constants were evaluated by means of computer-calculated graphs (table 2). These relationships and regressions equations are of immediate interests for the practical estimating of seed sorting on gravity separator.

The influence of the complex of seed properties on the separation effectiveness was evaluated by means of using the mathematical method of pattern recognition. Because of the necessary of high labor input for measuring of seed properties the equation of separation was determined only for wheat seed:

$$y = -0.791\rho - 0.099 a - 0.067 b - 0.033 c + 0.014\varphi - 0.005 v + 0.599 z \quad (2)$$

where: ρ - seed specific gravity; a, b and c are the respective seed sizes length, width and thickness; φ - kinetic frictional coefficient; v - terminal velocity; z - volume shape factor.

Table 2. Relationships between mass of 1000 seeds and quantities of the sorted materials (from the lower end of discharge edge to its higher end).

Model	Coefficients				Std. dev.	Coef. of correl.
	a	b	c	d		
rye a+b*q	33.33	-0.078	-	-	0.80	0.97
field pea a*exp((-b-x)^2/(2*c^2))	209.6	49.28	164.0	-	1.33	0.96
oats a/(1+exp(b-cx)^(1-d))	45.52	-2.69	-0.026	4.55	0.12	0.99

Analysis of this equation (2) showed that seed specific gravity, volume shape factor and seed sizes have a dramatic effect on the separation effectiveness.

From conducted investigations we inferred that it is appropriate to grade seeds according to seed length and seed thickness before treatment on gravity separators. Experimentally, we confirmed that dividing seed on different fractions on indented cylinder and screens with slotted holes before separation on gravity separators allows to increase efficiency of separation. For example, wheat seeds were divided with indented cylinder (the diameter of pocket of inner surface of indented cylinder was \varnothing 6.5 mm) in two fractions and then each fraction was separately treatment on gravity separator. It gave enable to increase the effectiveness separation on the average, about 12...15 %.

The experimental tests have been carried out to determine the separation effectiveness of the mountain bluet (weed seed, difficult separated) from alfalfa seeds. These tests allowed us to obtain new more effective technological scheme (Fig. 3). According to this scheme initial material has been divided in two fractions then each fraction (4 and 5) was treated separately on the gravity separator. This fractional scheme allow to increase the effectiveness separation of alfalfa seeds on the average, above 13...15 %.

The optimum technological parameters of gravity separators were obtained for cereals and for grass seeds. For cereals: amplitude of deck oscillation – 8...9 mm; frequency of deck oscillation – 8...9 s⁻¹; air velocity over deck – 1.1...1.3 m/s; longitudinal angle of deck – 6...8°; transversal angle – 3...4°. For grass land: amplitude of deck oscillation – 4...7 mm; frequency of deck oscillation – 6...7 s⁻¹; air velocity over deck – 0.8...1.1 m/s; longitudinal angle of deck – 5...6°; transversal angle – 1...2°.

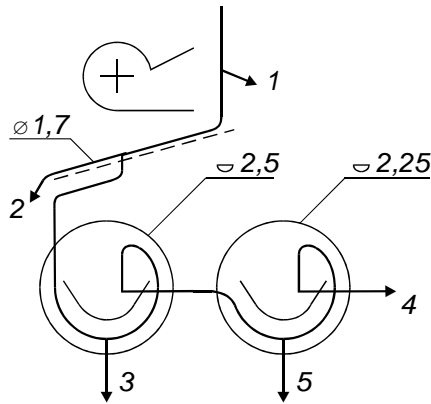

Figure 3. Fractional processing scheme alfalfa seed cleaning with dividing initial materials in two fractions: 1 – lights impurities; 2 – large impurities; 3 – long impurities; 4 – short particles fraction; 5 – long particles fraction, (gravity separator on this scheme is not shown)

CONCLUSIONS

- The gravity separator produce a specific gravity separation and also a definite size separation, as measured by the volume of 1000 seeds, when used to sort rye seed, field pea and oats seeds.
- For proper stratification of different density fractions, the seed mixture must be screened or/and divided on indent cylinders beforehand so that all particles are of the same size.
- Amplitude (a) and frequency (ω) oscillation of deck of gravity separator are related in their effect on the separation effectiveness and an optimum combination is required to obtain maximum separation effectiveness. These values can be obtained from equation $c=a\cdot\omega^2$, c – constant for definite conditions of separation.

ACKNOWLEDGMENTS

The authors would like to thank the collaborators of the seed cleaning and sorting laboratory of All Russian Institute of Agricultural mechanization for their cooperation and assistance for measurements of seed physical properties and for help in performing the tests.

REFERENCES

1. BRADENBURG N.R. (1977) The principles and practice of seed cleaning: separation with equipment that senses dimensions, shape, density and terminal velocity of seeds. *Seed science and technology*. № 5; 173-186.
2. GAUL A.D., MISRA M.K., BERN C.J. AND HURBURG C.R. (1986) Variation of Physical Properties in Gravity Separated Soybeans. *Transactions of the ASAE*. 29 (4); 1146-1149.
3. GORIAL B.Y., O'CALLAGHAN J.R. (1990) Aerodynamic Properties of Grain/Straw Materials. *Joyrnal of agricultural engineering research*. 46 (4), 275-290.
4. MISRA M.K., GAUL A.D. AND KAYODE O. (1985) Soybean seed quality during condition. *Transactions of the ASAE*. 28 (2); 576-579.
5. TSANG-MUI-CHUNG M., VERMA L.R. AND WRIGHT M.E. (1984) A device for friction measurement of Grains. *Transactions of the ASAE*. 27 (4); 1938-1944.

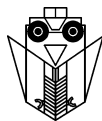

RACIONALIZACIJA BROJA KOMBAJNA NA PODRUČJU SIROVINSKE SLUŽBE “SLADORANA D. D. ŽUPANJA”

ZLATKO MENALO¹, LUKA ŠUMANOVAC², DUŠAN BRKIĆ²,
TOMISLAV JURIĆ², MLADEN JURIŠIĆ², DARIO KNEŽEVIĆ²

Obrtničko industrijska škola, Županja¹
Poljoprivredni fakultet Osijek, Osijek²

SAŽETAK

Racionalizacijom broja kombajna za sređivanje korijena šećerne repe značajno utječemo na smanjivanje troškova uporabe poljoprivredne mehanizacije i inih troškova tijekom proizvodnje šećerne repe. Proizvodnja šećerne repe koju prerađuje “Sladorana d. d. Županja” locirana je u radijusu od 165 km, s velikim brojem raznovrsnih kombajna i linija različite tehničko-tehnološke razine, što rezultira visokim stupnjem neracionalnosti uporabe.

Ključne riječi: racionalizacija, šećerna repa, optimalizacija, kombajn.

UVOD

Pred kombajne za vađenje korijena šećerne repe postavljeni su točno definirani agrotehnički zahtjevi kojima isti moraju udovoljiti, a da se pri tome vodi računa o zadovoljavanju postojećih kapaciteta sladorane. Kako bi minimalizirali troškove vađenja, a da pri tom udovoljimo oba zahtjeva moramo utvrditi, tj. optimalizirati strukturu i broj kombajna.

Cilj rada je doprinos otklanjanju ili smanjivanju ove neracionalnosti i optimalizacija broja kombajna s minimalizacijom troškova proizvodnje šećerne repe. Naime veći broj strojeva za vađenje korijena šećerne repe iziskuje veću nabavnu cijenu, veće troškove održavanja, amortizacije, itd., što ima za posljedicu veću proizvođačku cijenu šećera. Istodobno manji broj kombajna od optimalnog rezultira nedovoljno izvađenim količinama šećerne repe, što pak utječe na smanjenje kapaciteta sladorane odnosno povećanje troškova proizvodnje šećera.

METODE ISTRAŽIVANJA

Istraživanje je obavljeno u sirovinskoj službi sladorane, a uzeti su podaci iz trogodišnjeg razdoblja (1997.-1999.). Analiziran je intenzitet vađenja tijekom navedenog razdoblja i temeljem podataka utvrdili smo da za približno iste površine koje su bile zasijane pod šećernom repom nisu uporabljavani istobrojni kombajni.

REZULTATI ISTRAŽIVANJA

Temeljem podataka dobivenih iz trogodišnjeg istraživanog razdoblja provedena je raščlamba čiji su rezultati prikazani grafički i tabelarno.

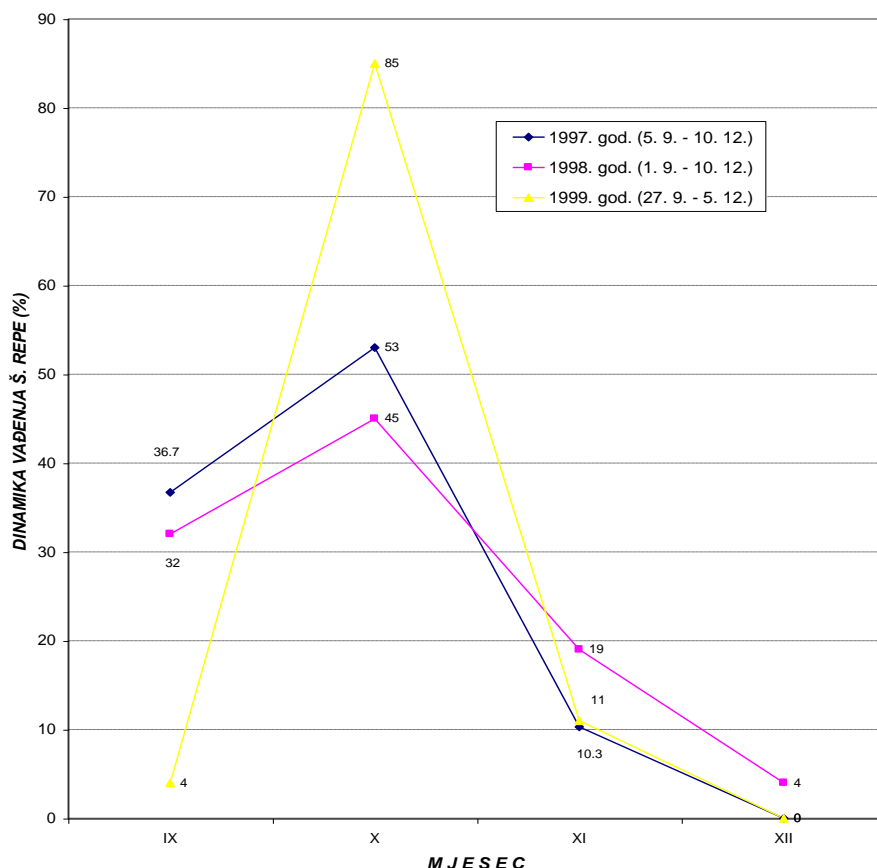

Slika 1. Dinamika vađenja korijena šećerne repe za razdoblje 1997. – 1999. godine na području sirovinske službe “Sladorana d. d. Županja”

Tablica 1. Postojeća struktura strojeva uporabljivanih tijekom 1998. godine

Vlasništvo	VRSTA, TIP I BROJ STROJEVA		
	"Lectra"	"Barigeli"	Linije
Sladorane	2	7	0
Privatno	30	32	4

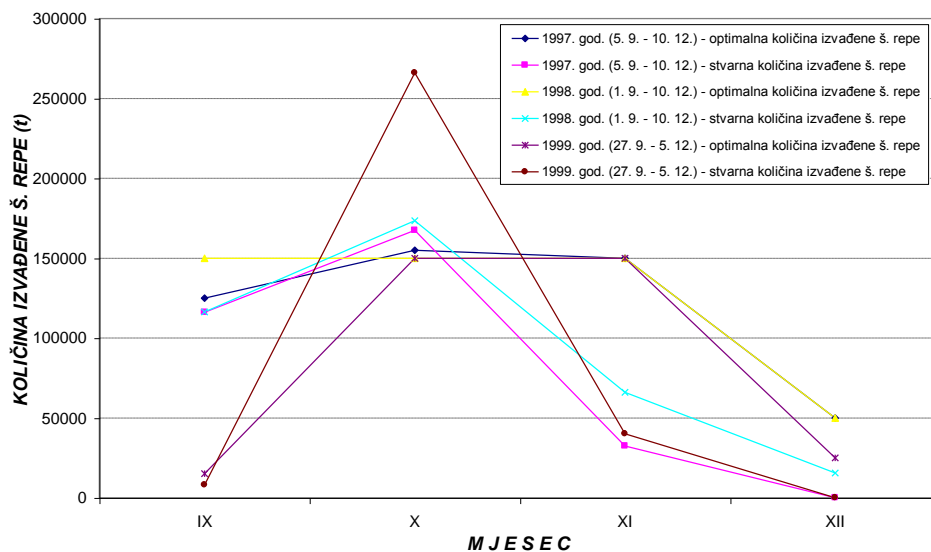

Slika 2. Optimalna i stvarna količina izvađenog korijena šećerne repe za razdoblje 1997. – 1999. godine na području sirovinke službe "Sladorana d. d. Županja"

Temeljem podataka o izvađenoj količini šećerne repe ostvarenih u trogodišnjem razdoblju izračunate su optimalne količine koje je potrebno izvaditi kako bi stupanj racionalnosti kombajna bio što veći, odnosno kako bi minimalizirali troškove vađenja, a time i smanjili troškove proizvodnje šećera.

Raščlambom podataka i kompariranjem krivulja optimalne i stvarne količine izvađenog korijena šećerne repe prezentiranih na slici 2 dolazimo do saznanja da je najmanje odstupanje istih realizirano tijekom 1998. godine. Ostvarene količine u inim godinama dalje se kompariraju sa rezultatima ostvarenim tijekom 1998. godine. Tijekom sezone vađenja korijena šećerne repe u 1999. godini odstupanje optimalne od stvarne količine izvađenog korijena je najveće, što implicira i uporabu većeg broja kombajna za vađenje, no međutim i ovaj povećani broj je znatno manji od stvarno upotrebljenog broja na sirovinskom području sladorane.

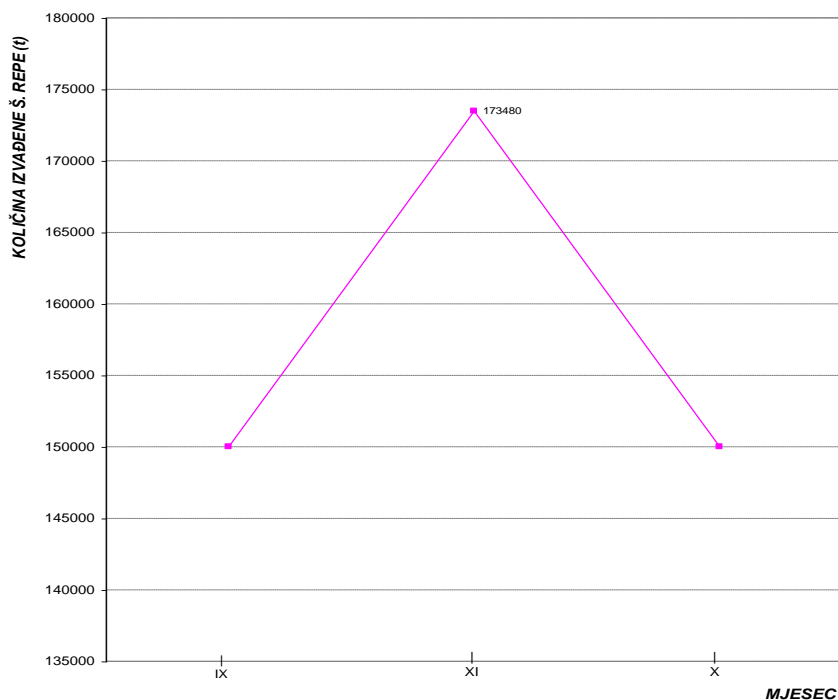

Slika 3. Najmanje odstupanje stvarne i optimalne količine izvađenog korijena šećerne repe

Ako pretpostavimo da 6 – redni kombajn za vađenje korijena šećerne repe ima učinak od 1 ha/h, pri urodu od 40 t/ha korijena šećerne repe, možemo izračunati potreban, odnosno racionalan broj kombajna, uz pretpostavku da se njihov broj uveća za 20 % u odnosu na racionalan zbog mogućih organizacijsko – tehničkih razloga.

$$W_{\text{Kombajna/danu}} = 8 * (1 - 20 \%) = 6,4 \text{ (ha/dan) ;}$$

$$W_{\text{izvađene mase/danu}} = W_{\text{Kombajna/danu}} * Q \text{ (prosječan urod)} = 6,4 * 40 = 256 \text{ (t/dan) ;}$$

$$W_{\text{tona/mjesecu}} = W_{\text{izvađene mase/danu}} * 30 \text{ (broj dana u mjesecu)} = 256 * 30 = 7680 \text{ (t/mjesec) ;}$$

$$N_{\text{kombajna}} = \frac{Q_{\text{max}} \cdot \text{mjesec}}{W_{\text{tona/mjesecu}}} = \frac{173480}{7680} = 22,58 \text{ kombajna za 1998. godinu}$$

$$N_{\text{kombajna}} = \frac{Q_{\text{max}} \cdot \text{mjesec}}{W_{\text{tona/mjesecu}}} = \frac{265920}{7680} = 34,62 \text{ kombajna za 1999. godinu}$$

ZAKLJUČAK

Na području sirovinke službe "Sladorana d. d. Županja" ustanovljeno je da tvornica zajedno sa privatnim vlasnicima neracionalno raspolaže sa većim brojem kombajna i to u iznosu od 75, dok bi u našem proračunu tijekom istraživanog razdoblja i u najekstremnijim uvjetima (1999. godina) bilo dovoljno raspolagati sa 35 strojeva. Ukoliko bi se postojeća struktura kombajna koja je dosta tehničko – tehnološki i konceptijski zastarjela smanjila na optimalan odnosno racionalan broj, troškovi vađenja korijena šećerne repe bi se na taj način mogli minimalizirati.

LITERATURA

1. BLAŽINKOV S.: (1980) Važniji pokazatelji iz proizvodnje i prerade šećerne repe 1979/90. Godine, Županja.
2. KRLJANOVIĆ M.: (1983/84) Analiza pokazatelja efikasnosti korišćenja železničkog transporta u prevozu korena šećerne repe, "Savremena poljoprivredna tehnika" br. 1-2 i br. 4, Novi Sad.
3. KOVAČIĆ A.: (1988) Kombinirani prijevoz šećerne repe iz NR Mađarske s naročitim osvrtom na racionalizaciju transporta u PIK-u "Belje" (magistarski rad), Fakultet za saobraćaj, Rijeka.
4. MENALO Z., ŠUMANOVAC L., BRKIĆ D., JURIĆ T., JURIŠIĆ M., KNEŽEVIĆ D.: (2001) Izbor racionalnog transporta korijena šećerne repe, zbornik radova 29. Međunarodnog simpozija iz područja mehanizacije poljoprivrede, Opatija.
5. PETROVIĆ M.: (1982) Primena traktora u transportu korena šećerne repe, "Savremena poljoprivredna tehnika" br. 3, Novi Sad.
6. PETROVIĆ M.: (1990) Troškovi koji nastaju zbog neusklađenosti istovarnih i transportnih kapaciteta u prevozu korena šećerne repe drumskim vozilima, "Savremena poljoprivredna tehnika" br. 3, Novi Sad.
7. ŠUMANOVAC L.: (1998) Racionalno korištenje sredstava poljoprivredne mehanizacije na obiteljskim gospodarstvima, "Poljoprivredna znanstvena smotra", Vol. 63, broj 1-2, Zagreb.
8. ŠUMANOVAC L., MENALO Z., BUKVIĆ Ž., JURIĆ T., BRKIĆ D., KIŠ D.: (2000) Utjecaj vrste transportnih sredstava na racionalizaciju transporta korijena šećerne repe, 36 znanstveni skup hrvatskih agronoma s međunarodnim sudjelovanjem "Postignuća i perspektive hrvatskog poljodjelstva" (zbornik sažetaka), Opatija.
9. ***: (1999) Izvještaj o proizvodnji šećerne repe za 1998. godinu u "Sladorani d.d.Županja", Županja.

RATIONALIZATION OF COMBINE NUMBER IN THE AREA OF RAW MATERIAL SECTION OF “SLADORANA P.L.C. ŽUPANJA”

SUMMARY

Rationalization of a combine number prepared for sugar beet root operation considerably affect costs reduction of agricultural mechanization use as well as other expenditures in sugar beet production. Production of sugar beet processed by “Sladorana p.l.c. Županja” is located within radius of 165 km with a larger number of diverse combines and lines of different technical-technological levels resulting in lack of cost effectiveness in their use.

This paper aimed to remove or reduce these cost effectiveness shortage but optimize combines number with minimum sugar beet production costs. Namely, a large number of machines for lifting sugar beet root requires higher purchase price, higher costs of maintenance, depreciation etc. leading to higher production sugar price. At the same time not enough combines brings about less lifted sugar beet amount which in turns affect reduction of sugar factory capacity i.e. sugar production costs increase.

Key words: *rationalization, sugar beet, optimization, combine*



SPREMANJE SJENAŽE I SILAŽE KOMBAJNOM CLAAS JAGUAR 860

RUŽICA ŠIMUNIĆ, JOSIP IPŠA, ROBERT ZIMMER, IVICA MARTINIĆ

Belje d.d. Poljoprivreda Brestovac
Belje d.d. Darda
Poljoprivredni fakultet Osijek

SAŽETAK

Na proizvodnim poljima Belje d.d. Poljoprivreda Brestovac u 2001. godini provedeno je ispitivanje učinkovitosti silažnog kombajna Claas Jaguar 860 pri košnji silažnog kukuruza hederom tipa RU i pri skupljanju provenute zelene mase krmne mješavine i lucerne za sjenažu uporabom Pick-upa.

Kod spremanja sjenaže pri prosječnoj radnoj brzini od 13,63 km/h i ostvarenom prirodnu od 9,96 t/ha silažni kombajn Claas Jaguar ostvario je najveći protok zelene mase od 55,60 t/h. Kod žetve silažnog kukuruza prosječnog prinosa zelene mase od 31,22 t/ha i prosječnog sadržaja suhe tvari od 36,23 % ostvaren je najveći protok zelene mase 100,61 t/h.

Ukupno je pokošeno i spremljeno 166 ha krmne mješavine i lucerne za sjenažu i silažnog kukuruza sa ostvarenim učinkom kombajna u sjenaži 2,63 ha/h, (uz prethodnu košnju zelene mase i nakon provenuća grabljanja u zbojeve), dok je u silaži ostvaren učinak kombajna 1,22 ha/h.

Ključne riječi: *sjenaža, silaža, silažni kombajn, propusna moć, prinos, suha tvar, utrošak goriva*



UVOD

Višegodišnja proizvodna iskustva na farmi Belje d.d. Poljoprivreda Brestovac pokazuju da je pri proizvodnji mlijeka i tovu junadi najekonomičnije kada se ishrana pretežno zasniva na zelenoj krmu, zatim sjenaži i silaži.

Dobra strana silaže je, što jednom napravljena može se upotrebljavati i duže od godinu dana. Njena je prednost u tome što se može koristiti dugo, bez obzira na vremenske prilike koje mogu ometati snabdjevanje zelenom krmom s njive, što je vrlo važno za postizanje visoke proizvodnje mlijeka (Mišković B.1983.).

Hrvatska (1995.) sa proizvodnjom 1818 litara mlijeka po kravi godišnje na razini je od 40 % u odnosu na Europu i zaostaje za svjetskim prosjekom u proizvodnji i mlijeka i mesa!

Kakvoća silaže ovisi o njenom sadržaju, energetske vrijednosti i uspješnosti fermentacije tvrdi Thajsen (1996.). Isti autor tvrdi da kakvoća silaže u znatnoj mjeri ovisi o vremenu košnje, duljini sječke i načinu spremanja silaže, odnosno uporabi odgovarajuće poljoprivredne tehnike.

U ovom su radu iznijeti neki rezultati ispitivanja rada silažnog kombajna Claas Jaguar 860 s hederom tipa RU za košnju silažnog kukuruza i s pick-up uređajem za sakupljanje pokošene zelene mase, te njihovo spremanje u horizontalne silose.

ZADATAK ISPITIVANJA

Zadatak ispitivanja je da se utvrdi protok svježe zelene mase i suhe tvari pri košnji silažnog kukuruza te spremanja zelene mase za sjenažu kombajnom Claas Jaguar 860 opremljenim hederom RU 450 i pick-up uređajem. Mjerenje prinosa silažnog kukuruza, lucerne i krmne mješavine, utvrde utrošak goriva i učinak kombajna. Da se prikaže način punjenja i «zatvaranja» horizontalnog silosa na farmi Mitrovac.

MATERIJAL I METODE

Ispitivanje eksploatacijskih pokazatelja rada silažnog kombajna (radna brzina, propusna moć, protok suhe tvari i potrošnja goriva) provedeno je na proizvodnim površinama Belje d.d. Poljoprivreda Brestovac u 2001. godini.

Radna brzina utvrđena je nakon višekratnih snimanja prolaznih vremena kombajna na putu od 100 m. Prinos zelene mase dobiven je nakon precizne odvage krme u svim transportnim jednoosovinskim prikolicama i mjerenja ukupno požete površine. Gorivo je u kombajn ulijevano putem mjernog protočnog uređaja koji je satavni dio mobilne cisterne za opskrbu gorivom. Učinak kombajna dobiven je nakon mjerenja požete površine mjernom trakom i evidentiranja stvarno utrošenog vremena. Sadržaj suhe tvari određivan je svaki dan u laboratoriju ZIK – a Belje d.d. Darda. Žetva silažnog kukuruza i sakupljanje zelene mase za sjenažu obavljeno je silažnim kombajnom čiji su podaci u tablici 1.

Tablica 1. Osnovni tehnički podaci kombajna Claas Jaguar 860

Motor	Mercedec Benz OM 400 LA
Raspored i broj cilindara	V - 8
Snaga motora (kW/KS)	320/435
Broj okretaja motora (min^{-1})	2100
Spremnik goriva (l)	815
Transmisija	Hidrostatska
Uvlačno kućište, širina (mm)	730
Valjci za uvlačenje i predprešanje (kom)	4
Bubanj s noževima	
širina (mm)	750
promjer (mm)	630
Broj okretaja bubnja (min^{-1})	1100
Raspored noževa	V – razmaknut
Broj polunoževa (komada)	24
Duljina sječke, teoretska (mm)	4; 5,5; 7; 9; 14 i 17
Ubrzivač s lopaticama «V» oblika, širina (mm)	680
Mogućnost zakretanja izlazne cijevi (stupnjeva)	180
Osnovni stroj; transportna duljina (mm)	6430
širina (mm)	2999/3294
visina (mm)	2999/3294
Radna duljina (mm)	5721
Visina (mm)	5100
Masa (kg)	10200

Kraći opis pick-up uređaja

Pick-up uređaj sastoji se od svinutih elastičnih zubaca, valjaka pritiskivača i uvlačne pužnice. Sakupljački uređaj ili pick-up sa strane je otvoren, tako da može skupljati i nejednake zbojeve. Tijekom ispitivanja rada kombajna broj okretaja uvlačnih valjaka bio je podešen na 270 min^{-1} . Podešena duljina sječenja 17 mm.

Kraći opis hedera RU 450

Heder tipa RU 450 namijenjen je za košnju visoke silaže. Radni zahvat je 4,5 m i na toj širini reže i uvlači sve stabljike. U transportu širina sklopivog hedera je 3 m. Heder čine dva mehanički pogonjena bočna razdjeljivača koji omogućuju sigurno uvlačenje zelene mase i tri velika zahvatna bubnja. Svaki se bubanj sastoji od horizontalno segmentiranih ploča koje prihvaćaju, režu i usmjeravaju masu k prihvatnoj pužnici. Tijekom ispitivanja rada

kombajna broj okretaja bubnja iznosio je 320 min^{-1} , a razmak između segmentiranih ploča bio je 10 cm. Podešena duljina sječenja 5,5 mm.

REZULTATI I RASPRAVA

Ispitivanje kombajna Claas Jaguar 860 pri spremanju sjenaže i silaže na Belju d.d. Poljoprivreda Brestovac provedeno je u 2001.godini.

Rezultati ispitivanja kombajna Claas Jaguar 860 pri skupljanju provenute zelene mase iz zboja (pokošene krmne mješavine i lucerne pograbljane u zbojeve nakon provenuća) i košnje silažnog kukuruza na proizvodnim površinama Poljoprivrede Brestovac prikazane su u tablicama 2 i 3.

Prilikom sakupljanja zelene mase za sjenažu pri prosječnoj radnoj brzini od 13,63 km/h i najvećem prosječnom prinosu jare krmne mješavine od 9,96 t/ha ispitivani kombajn Claas Jaguar 860 postigao je najveći prosječni protok (propusnu moć) svježe zelene mase od 55,60 t/h. Isti kombajn pri košnjoj silažnog kukuruza kod prosječne radne brzine od 8,57 km/h i prosječnog prinosa od 31,22 t/ha zelene mase kukuruza i sadržaja suhe tvari od 36,23 % ostvario je najveći protok zelene mase od 100,61 t/h, odnosno 36,45 t/h suhe tvari.

Tablica 2. Prosječna radna brzina, prinos svježe zelene mase, sadržaj suhe tvari, protok svježe zelene mase i protok suhe tvari pri skupljanju provenute zelene mase krmne mješavine i lucerne

<i>Kultura</i>	<i>Prosječna radna brzina</i> km/h	<i>Prosječan prinos svježe zelene mase</i> t/ha	<i>Prosjek suhe tvari</i> %	<i>Protok svježe zelene mase</i> t/h	<i>Protok suhe tvari</i> t/h
<i>Jara krmna mješavina</i>	13,63	9,96	34,11	55,60	26,94
<i>Jara krmna mješavina</i>	13,84	9,96	38,43	33,72	12,96
<i>Jara krmna mješavina</i>	10,27	9,96	46,31	32,60	15,09
<i>Lucerna</i>	12,97	9,07	42,31	40,43	17,10
<i>Lucerna</i>	15,37	9,07	40,37	42,53	17,17

Tablica 3. Radna brzina, protok zelene mase i suhe tvari pri košnji silažnog kukuruza prosječnog prinosa 31,22 t/ha zelene mase i sadržaja suhe tvari 36,23 %

Prosječna radna brzina	Protok zelene mase	Protok suhe tvari
km/h	t/h	t/h
8,80	85,48	30,97
8,15	90,83	32,91
7,23	81,60	29,56
8,19	89,59	32,46
7,30	81,60	29,56
7,96	89,59	32,46
8,23	97,80	35,43
7,70	81,51	29,53
8,02	89,07	32,27
8,57	100,61	36,45
7,78	82,06	29,73
7,84	90,65	32,84
7,78	82,67	29,95
Prosjek: 8,64	Prosjek: 87,93	Prosjek: 31,86

Tijekom sakupljanja zelene mase za sjenazu i košnje silažnog kukuruza u 2001. godini bilježeni su podaci koji su se odnosili na ukupno pokošenu površinu i odveženu zelenu masu u horizontalni silos, stvarno utrošeni sati rada kombajna i utrošak goriva za rad silažnog kombajna Claas Jaguar 860 (tablice 4 i 5).

Tablica 4. Utrošak goriva i učinak silažnog kombajna Claas Jaguar 860 pri spremanju sjenaze od krmne mješavine i lucerne na farmi Mitrovac

Ukupno pokošena zelena masa (t)	1193,80
Pokošena površina (ha)	166,00
Efektivni sati rada kombajna (h)	63,00
Ukupna potrošnja goriva (l)	1534,00
Potrošnja goriva D-2 : (l/ha)	9,24
(l/h)	24,35
(l/t)	1,28
Učinak kombajna (ha/h)	2,63

Tablica 5. Utrošak goriva i učinak silažnog kombajna pri spremanju silažnog kukuruza na farmi Mitrovac

Ukupno pokošena zelena masa (t)	5260,70
Pokošena površina (ha)	166,00
Efektivni sati kombajna (h)	136,00
Ukupna potrošnja goriva D-2 (l)	5124,00
Potrošnja goriva D-2: (l/ha)	30,86
(l/h)	37,68
(l/t)	0,97
Učinak kombajna (ha/h)	1,22

S obzirom na učinak kombajna prilikom skupljanja zelene mase za sjenažu od 2,63 ha/h i 1,22 ha/h pri košnji silažnog kukuruza, te utroška goriva 24,35 l/h u sjenaži, odnosno 37,68 l/h u silaži, ispitivani kombajn je dobro eksploatiran. Ukoliko se analizira utrošak goriva po toni zelene mase (1,28 l/t i 0,97 l/t) stoji primjedba da nije dovoljno eksploatiran (prema lit. 1).

Spremanje mase krmne mješavine i lucerne za sjenažu i kukuruzne silaže obavljeno je u horizontalni silos s tim da je iskorišten samo dio ukupnog volumena betonskog silosa. U 2001. godini sjenažom je ispunjeno 2025 m³, a kukuruznom silažom 1290 m³.

Dopremljena masa pomoću traktora gusjeničara sa ugrađenom daskom raširivana je na debljinu sloja 30 cm i zatim gažena s dva traktora (snage 155 kW) s udvojenim pneumaticima. Punjenje silosa sjenažom i silažom trajalo je pet radnih dana s tim da je tokom spremanja kukuruzne silaže u isto vrijeme punjen u blizini farme i tzv. zemljani silos.

U betonskom horizontalnom silosu spremljeno je 1 023 670 kg svježe zelene mase silažnog kukuruza, prosječne suhe tvari 36,23 %. Volumna gustoća svježe zelene mase silažnog kukuruza iznosila je 794 kg/m³, a suhe tvari 288 kg/m³. U horizontalnom silosu volumna gustoća svježe zelene krmne mješavine i lucerne iznosila je 581,77 kg/m³ a suhe tvari 234,51 kg/m³.

U Poljoprivredi Brestovac nakon ispunjenja silosa na zelenu masu kukuruzne silaže po cijeloj površini posijan je merkantilni ozimi ječam koji prorastanjem (10-15 cm) površinskog sloja spremljene mase proizvodi «zeleni pokrivač» i na taj način djelomično štiti silažu od nepovoljnih klimatskih uvjeta. Takav način pokrivanja silosa stvara određene gubitke, ali su oni prema našim višegodišnjim iskustvima relativno mali. Za pokrivanje sjenaže korištena je crna folija debljine 1 mm i na nju su složene male četvrtaste bale slame.

ZAKLJUČAK

Na osnovu ispitivanja rada kombajna Claas Jaguar 860 opremljenog pick-up uređajem za sakupljanje zelene mase iz zboja, te hederom tipa RU u košnji visoke silaže i dobivenih rezultata mogući su sljedeći zaključci:

- najveća propusna moć silažnog kombajna od 55,60 t/h dostignuta je pri prosječnoj radnoj brzini od 13,22 km/h i pri prosječnom prinosu krmne mješavine 9,96 t/ha prilikom skupljanja zelene mase iz zboja;
- u usporedbi sa sjenažom pri košnji visoke silaže ostvarena je za 55,26 % veća propusna moć kombajna, odnosno 100,61 t/ha;
- za sakupljanje sjenaže ukupno je pokošeno 166 ha jare krmne mješavine i lucerne, uz učinak kombajna 2,63 ha/h i utrošak goriva po toni pokošene zelene mase 1,28 l/t;
- za spremanje silaže pokošeno je 166 ha silažnog kukuruza, uz učinak kombajna od 1,22 ha/h i utrošak goriva po toni pokošene zelene mase 0,97 l/t.

LITERATURA

1. ČULJAT, M., BARČIĆ, J.(1997.): Poljoprivredni kombajni, Poljoprivredni institut Osijek, Osijek.
2. HEINRICHSMAYER, F. (1996.): Krmni kombajn može se bolje ikoristiti, Agrotehničar,4,4, Zagreb.
3. THAJSEN, J. (1996.): Silaža željene kakvoće, Agrotehničar 3,12-14, Zagreb.
4. ŠIMUNIĆ, R., ZIMMER, R., MARTINIĆ, I., JURIŠIĆ, M. (2001.): Žetva silažnog kukuruza kombajnom Claas Jaguar 840, Savjetovanje, Aktualni zadaci mehanizacije poljoprivrede, Opatija, 227-233.
5. Uputstvo za rad silažnog kombajna Claas Jaguar 860, tvornički materijal.

HAYLAGE AND SILAGE STORING BY CLAAS JAGUAR 860

SUMMARY

Investigation of silage combine Claas Jaguar 860 efficiency at silage maize mowing by RU type header as well as at collecting wilted forage mixture green mass and haylage alfalfa by Pick-up device was conducted on production fields of Belje p.l.c. Poljoprivreda Brestovac in 2001.

The highest green mass flow of 55,60 t/h was accomplished by a silage combine Claas Jaguar during the haylage storing at average work speed of 13,63 km/h attained yield of 9,96 t/ha. Harvest of the silage maize having average green mass yield of 31,22 t/ha and average dry matter content of 36,23 % was known for the highest green mass flow being 100,61 t/h.

Total of 166 ha of forage mixture, haylage alfalfa and silage maize was mowed and stored with haylage combine effect of 2,63 ha/h (preceded by green mass mowing and post wilting windrow rakinag). However, the silage combine effect was 1,22 ha/h.

Key words: *haylage, silage, field ensilage harvester, permeability, yield, dry matter, fuel consumption*



STANJE APARATA ZA ZAŠTITU BILJA POSLIJE PROVJERAVANJA U 2000. I 2001. GODINAMI I NAJČEŠĆI KVAROVI

BRANKO ŠKET, MARTIN ŠKET

Kmetijska in gospodinjska šola
Šentjur, Slovenija

SAŽETAK

Rad obuhvaća provjeravanje aparata za zaštitu bilja u 2000. i 2001. godini u celjskoj regiji i istraživanje kvarova kroz cijelo vrijeme provjeravanja.

U 2000. i 2001. godini provjeravanje je izvedeno na 177 aparata za zaštitu bilja. Primjenom obaveznog provjeravanja, stanje aparata za zaštitu bilja se znatno poboljšalo i stabiliziralo.

Kvarova je sve manje i tako je ispravnost aparata za zaštitu bilja koji su na provjeravanju u 2000. godini 96,91 % a u 2001 godini 100 % po provjeravanju i servisiranju.

Prosječno u cijelom vremenu provjeravanja najviše kvarova je na manometrima, poslije sapnicama, pipama, protukapnom mehanizmu, regulatorima i ostalih kvarova a manje na pumpama i armaturama.

Ključne riječi: zaštita bilja, provjeravanje, kvarovi, stanje aparata

UVOD

Pravi izbor strojeva za zaštitu bilja i izvođenje redovitih pregleda, jedini su način, koji može pripomoći kvalitetnijem i zdravijem prirodo. Temeljna namjera je, utvrditi stanje parametara eksploatacijskog potencijala aparata, tehničkih mana ili nedostataka, otkloniti ih i dati potrošaču aparata posebne stručne upute za pravilno vođenje radnog procesa i tehničkog održavanja. Kod pumpi aparata za zaštitu bilja važan je pravilno postavljen tlak, pravilno protjecanje, odgovarajuća kapaciteta pumpe i radna sigurnost. Sve te parametre možemo provjeriti slijedećim napravama:

- manotest

- dositest
- mjerač protoka
- mjerač okretaja

Svi ti parametri utječu na stanje strojeva za zaštitu bilja, što je posebno naglašeno u tom kratkom zadatku.

Uvođenjem zakonsko obaveznog testiranja aparata za zaštitu bilja, stanje tih aparata značajno se promijenilo, što omogućuje kvalitetnije nanošenje pripravaka, manje oštećenje pripravaka na pod, kao i racionalnija potrošnja pripravaka.

U radu »Poboljšanje eksploatacijskih karakteristika aparata za zaštitu bilja primjenom zakonsko obaveznog provjeravanja« (Zbornik radova 28. Međunarodnog simpozija iz područja mehanizacije poljoprivrede u Opatiji – B. Šket, M. Šket) utvrđeno je da je bilo stanje aparata za zaštitu u celjskoj regiji vrlo loše iako se poboljšavalo. U godinama provjeravanja 1989. – 1994. bilo je prosječno 19,32 % aparata za zaštitu ispravnih, a 80,68 % neispravnih.

U godinama zakonskog obaveznog provjeravanja 1995. – 1999. se je stanje znatno poboljšalo, bilo je prosječno 92 % ispravnih, a 8% neispravnih.

U ovom radu obradjeno je stanje aparata za zaštitu bilja u celjskoj regiji u 2000. i 2001. godini i usporedba kvarova kroz cijelo vrijeme provjeravanja.

METODE RADA

Postupak terenskog provjeravanja ispravnosti aparata odvija se u nekoliko odvojenih cjelina:

- vajnski vizuelni pregled aparata za zaštitu i pripremni radovi za mjerenje,
- mjerenje osnovnih tehničkih parametara, koji osiguravaju pravilan rad aparata za zaštitu.

U cilju provodjenja objektivne i egzaktne provjere eksploatacijskih parametara potrebno je izmjeriti i utvrditi vrijednosti određenih tehničkih parametara o kojima ovisi pravilan rad aparata za zaštitu. U tu svrhu provode se slijedeća mjerenja:

- mjerenja broja okretaja priključnog vratila
Mjerenja broja okretaja priključnog vratila vršena su elektronskim brojačem okretaja, što je značajno radi moguće provjere opterećenja pumpe u momentu uključivanja svih potrošača.
- provjera tlaka zraka u tlačnoj komori pumpe
- provjera točnosti djelovanja instrumenata za mjerenje i pokazivanje radnog tlaka (manometri, quantometri)
- mjerenje parametara eksploatacijskog potencijala

Nakon obavljenog vizuelnog pregleda aparata za zaštitu, te izmjerenih tehničkih parametara koji osiguravaju pravilan rad aparata za zaštitu, pristupa se mjerenju parametara eksploatacijskog potencijala.

Postupak obuhvaća slijedeće:

- mjerenje ukupnog protoka (kapaciteta) pumpe $Q_p(l/min.)$
- mjerenje protoka na svim potrošačima aparata za zaštitu i utvrđivanje njihove međusobne uskladenosti

Postupak obuhvaća mjerenje slijedećih parametara: ukupni protok svih sapnica, protok pojedinačnih segmenata armature za prskanje, protok namjenjen za hidrauličko miješanje zaštitnog sredstva i pojedinačni protok sapnica.

Sva mjerenja količine protoka, pri testiranju provedena su elektronskim mjerачima protoka.

- Mjerenje količine povratne tekućine (l/min) u svrhu hidrauličkog miješanja.
- Mjerenje ravnomjernosti poprečne raspodjele zaštitnog sredstva.

REZULTATI MJERENJA

Opći podaci o ispitivanim agregatima i osnovna zapažanja

Glavne podatke o strukturi ispitivanja strojeva prikazuju tabele. Ispitivanjem je obuhvaćeno 177 pojedinačnih traktorskih agregata. Ispitani agregati pretežno su proizvodi domaće industrije. Prevladaju aparati tvornice Agromehanika iz Kranja – 68,4%, zatim Metalna Rau – 19,8% i ostale 11,8%.

Pregled ispitanih aparata po godinama testiranja

Tablica 1. Pregled ispitanih aparata po tipovima i godinama testiranja

Godina ispitivanja	Agromehan		Rau		Ostale	
	kom. %		Kom. %		Kom. %	
2000	66	68	18	18,6	13	13,4
2001	55	68,75	17	21,25	8	10
Ukupno	121	68,4	35	19,8	21	11,8

Terenskim provjeravanjem aparata za primjenu pesticida, može se ustanoviti stanje aparata za primjenu pesticida na nekom području. O stanju aparata ovisi zatrovanost tla i biljaka odnosno plodova. Terenskim provjeravanjem aparata poboljšava se stanje aparata čime se dolazi do zdravije hrane i manjeg zagađivanja okoline. Poslije zakonsko obaveznog provjeravanja, a pogotovo zadnje tri godine puno je bolje stanje prskalica u celjskoj regiji.

Tablica 2. Stanje aparata

Godina testiranja	Testirani agreg.		Ispravnih		Neispravnih	
	Kom %		Kom %		Kom %	
2000	97	100	94	96,9	3	3.1
2001	80	100	80	100	0	0
Ukupno	177	100	174	98,3	3	1,7

Tablica 3. Kvarovi u 2000. i 2001. godini

Godina testiranja	2000	2001	Ukupno
KVAROVI			
Svih kvarova, kom.-%	92-100	65-100	157-100
Manometri, kom.-%	31-38,7	18-27,7	49-31,2
Pumpe, kom.-%	5-5,4	6-9,2	11-7
Regulatori kom.-%	8-8,7	6-9,2	14-8,9
Sapnice, kom.-%	17-18,4	10-15,4	27-17,2
Armature kom.-%	1-1,1	0-0	1-0,6
Pipe, zasuni, kom.-%	9-9,8	10-15,4	19-12,1
Protukapni mehanizam, kom.-%	10-10,9	9-13,9	19-12,1
Ostalo, kom.-%	11-12	6-9,2	17-10,9

Tablica 4. Kvarovi za vrijeme prostovoljnog provjeravanja 1989 i 1994 godine

Godina testiranja	Svih kvarova kom.	Manometri kom.	Pumpe kom.	Regulatori kom.	Sapnice kom.	Armature kom.
1989	262	72	26	82	76	6
1994	195	80	26	37	44	8
Ukupno	457	152	52	119	120	14

Tablica 5. Kvarovi – zakonsko obavezno provjeravanje 1995-2001 godine

Godina testiranja	1995	1996	1997	1998	1999	2000	2001	Ukupno
KVAROVI								
Svih kvarova, kom.	174	293	301	108	100	92	65	1133
Manometri, kom.	28	56	62	16	26	31	18	237
Pumpe, kom.	9	4	13	11	5	5	6	53
Regulatori kom.	20	48	47	15	12	8	6	156
Sapnice, kom.	27	54	39	22	21	17	10	190
Armature kom.	4	3	2	3	1	1	0	14
Pipe, zasuni, kom.	30	51	56	14	12	9	10	182
Protukapni mehanizam, kom.	26	52	37	14	13	10	9	161
Ostalo, kom.-%	30	25	45	13	10	11	6	140

DISKUSIJA REZULTATA ISTRAŽIVANJA

Iz izložene problematike i rezultata istraživanja vidljivo je da se tehničkim provjeravanjem aparata za zaštitu poboljšalo stanje i s time poboljšalo se iskorištenost njihovog eksploatacijskog potencijala, a time se povećala kvaliteta i preciznost aplikacije pesticida.

Ispitivanjem aparata za zaštitu u uvjetima eksploatacije, utvrđeno je da je stanje aparata u zadnje dvije godine bolje i stabilnije.

Na provjeravanju koje izvodi naša škola bilo je najviše aparata za zaštitu bilja proizvodnje tvornice Agromehanika i to 68,4%, zatim RAU sa 19,8 % a ostale 11,8%.

U godinama provjeravanja 2000 i 2001 bilo je prosječno 98,45 % aparata za zaštitu ispravnih, a 1,55 % neispravnih po provjeravanju i servisiranju.

Kvarovi:

- 31,2 % kvarova na manometrima
- 17,2 % kvarova na sapnicama
- 12,1 % kvarova pipama, zasunima
- 12,1 % kvarova na protikapnom mehanizmu
- 10,9 % ostalih kvarova
- 8,9 % kvarova na regulatorima
- 7 % kvarova na pumpama
- 0,6 % kvarova na armaturama

Iz tablice 4 vidljivo je, da je prvo godinu provjeravanja 1989 bilo najviše kvarova na regulatorima odnosno nisu bili pravi ugrađeni, sapnicama, manometrima, a manje na

pumpama i armaturama. Zadnju godinu prostovoljnog provjeravanja bilo je najviše kvarova na manometrima a manje na sapnicama, regulatorima, pumpama i armaturama. Ukupno za vrijeme prostovoljnog provjeravanja bilo je najviše kvarova na manometrima poslije sapnicama, regulatorima a manje na pumpama i armaturama.

Iz tablice 5vidljivo je, da je za vrijeme obaveznog provjeravanja od 1995 – 2001 ukupno najviše kvarova na manometrima, poslije sapnicama, pipama, protukapnom mehanizmima, regulatorima, ostalih kvarova a manje na pumpama i armaturama.

ZAKLJUČAK

Osnovni cilj proučavanja utjecaja tehničkog provjeravanja aparata za zaštitu u zadnje dvije godine, bilo je utvrđivanje stanja aparata u godinama 2000. i 2001., utjecaj provjeravanja zadnji dvije godine na stanje i poboljšanje eksploatacijskih parametara i utvrđivanje najčešćih kvarova u cijelom vremenu provjeravanja. Ispitivanjem najznačajnijih tehničkih parametara aparata za zaštitu utvrđeno je da je stanje aparata u zadnje dvije godine bolje i stabilnije.

Na osnovu rezultata terenskog provjeravanja provedenih u godinama 2000 i 2001 moguće je istaknuti neke osnovne zaključke:

- Poboljšava i stabilizira se stanje aparata za zaštitu
- Smanjuje se broj kvarova,
- Poboljšava se iskorištenost eksploatacijskog potencijala
- Poboljšava se kvaliteta i preciznost aplikacije pesticida

Na osnovu rezultata terenskog provjeravanja i utvrđivanja kvarova provedenih za cijelo vrijeme provjeravanja moguće je utvrditi, da je najviše kvarova na manometrima poslije sapnicama, pipama, protikapnom mehanizama, regulatorima, ostalih kvarova a manje na pumpama i armaturama. Postavlja se pitanje, zašto je najviše kvarova na manometrima?? – Vjerovatno zbog nepravilnog skladištenja - zima i neprimjereno mjerno područje i upotreba aparata u više namjena u kojima se manometar preoptereti.

Proučavanje tehničkog provjeravanja aparata za zaštitu bilja potvrđuje da zakonsko obaveznim provjeravanjem aparata za zaštitu bilja brzo se poboljšava stanje aparata, što ima vrlo značajnu ulogu u proizvodnji zdrave hrane.

LITERATURA

1. DUVNJAK V., (1989): Prilog proučavanju nekih tehničkih parametara prskalica, Magistarski rad, Fakultet poljoprivrednih znanosti, Zagreb.
2. MACELJSKI M., (1992): Metode i aparati za primjenu pesticida, Agronomski Fakultet Zagreb
3. NOVAK M., MAČEK J., (1990): Tehnike nanašanja pesticidov, ČZP Kmečki Glas, Ljubljana
4. ŠKET B., (1995): Utjecaj provjeravanja aparata za zaštitu bilja na poboljšanje eksploatacijskih potencijala, Magistarski rad, Agronomski Fakultet Zagreb

5. ŠKET B., ŠKET M., (2000): Poboljšanje eksploatacijskih karakteristika aparata za zaštitu bilja primjenom zakonsko obaveznog testiranja, *Aktuani zadaci mehanizacije poljoprivrede, Opatija*, S. 211 - 217
6. ŠKET B., ŠKET M., (2001): Vpliv testiranja na korišćenje eksploatacijskega potencijala strojev za varstvo rastlin z uvedbo zakonsko obveznega testiranja, *Trendi v razvoju kmetijske tehnike, Radenci*, S. 205 - 211
7. Pravilnik o uslovima, koje moraju ispunjevati ovlaštene organizacije za redovite preglede naprava za rasporedjivanje fitofarmaceutskih sredstava *Službeni list Republike Slovenije*, 12/2000
8. Pravilnik o sadržaju i načinu vođenja registra (aparata) naprava certificiranih tipova, koji su uspješno donosno neuspješno izdržali redoviti pregled, *Službeni list Republike Slovenije*, 68/1995

**REVIEW OF PLANT PROTECTION EQUIPMENT CONDITION AND
THE MOST FREQUENT FAILURES AFTER COMPULSORY
CHECKING IN THE YEAR 2000 AND 2001**

SUMMARY

The paper presents results of plant protection equipment compulsory checking in Celje region during last two years period. During the two years 177 plant protection devices were checked. Results analysis showed that in 2000. there were 96.91% correct devices, while in 2001. percentage of correct devices increased to 100%. The most frequent failures were detected at pressure gauge, nozzles, shut-off valves and control valves, while at pumps and booms less failures were detected.

Key words: *Plant protection equipment, obligatory checking, failures*



ENERGY FROM BIOMASS IN ITALIAN AGRICULTURE: STATE OF THE ART

LUIGI PARI, MAURIZIO CUTINI

ISMA (Istituto Sperimentale per la Meccanizzazione Agricola)
Rome, Italy

SUMMARY

The paper reports the result of olive pruning combustion test.

The pruning chemical composition and the thermotechnical characteristics are reported.

The environmental performance were evaluated following the Externè Project methodology with the aim to compare the environmental costs (mEuro/MJth) of different fuels, both fossils and biomass.

It was pointed out that a biomass commercial boiler can be used without any adaptations with olive pruning as the test reported an efficiency of 67% and emissions in the low range.

It was finally found that olive pruning has an environmental cost equal to methane combustion.

Key words: *biomass, olive pruning, combustion, environmental impact*

INTRODUCTION

Italy has a great foreign energetic dependence (more than 80%).

In 1999 the internal consumption has been 183 Mtep.

The energetic sources utilized have been the petroleum for the 50,7%, methane for the 30,6% and the 7,4% of renewable.

So there is a problem of security and diversification of energy supply.

In south Italy farmers usually burn stubbles and pruning on the fields with strong environmental impact.

To verify the possibility to increase the energetic value of those pruning that actually are burned, the Italian Agricultural Ministry and the European Union, has financed the research project POM B14 on the Calabria and Sicilia regions to achieve the following objectives:

Action 1 – Evaluation of the pruning quantity

Action 2 – Study and definition of the machines more suitable to harvest biomass from the field

Action 3 – Study the logistic problems of the biomass transport and the pre-treatment: drying and storage.



Figure 1. Olive pruning

Strategic objective: start bio-energetic chain economically and environmentally sustainable.

In the two regions pruning annually produced is 2 Mt (tab.1) and the cost of harvesting and transport out of the field has been evaluated with tests of several harvester, in about 25 €/t

This work reports the achievements of the combustion test of olive pruning to verify:

1. if the commercial biomass boiler are suitable for pruning combustion: adaptation of the feeding system, evaluation of the thermodynamic performance...
2. thermochemical pruning properties: gas evaluation, ashes analysis...
3. the environmental impact of fossil fuel substitution with pruning

Table 1. Annual pruning production in Calabria and Sicily

Specie	Sicily		Calabria	
	ha	t	ha	t
Peach	5.785	21.781	3.377	16.940
Citrus	106.944	374.304	42.554	148.939
Olive	158.252	633.008	185.481	741.924
Grapes	17.299	60.547	491	2.701
Tot.	288.280	1.089.640	231.903	910.504
Tot. biomass			2.000.144	

MATERIALS AND METHODS

The test plant

A boiler of the D'Alessandro Termomeccanica of 400.000 kcal has been used for the test.

The plant has a primary air coming from the screw feeder of the burner and a secondary air to complete the combustion at about thirty centimetres above the flame.

Fuel properties

The fuel used has been harvested by a machine developed from ISMA.

Before the combustion test biomass has been analysed to identify humidity, calorific value and chemical composition all physical characteristic important for storage, feeding and combustion.

Olive pruning had a humidity at the harvest, after one month from the cut, of 37%, after the harvesting and chipping has been left two weeks to dry at the air and was burned at a value of 12%.

As shown in tab. 2, the carbon value was lower than the other biomasses, 41,2% against an average of the 45%.

Anyway the hydrogen value was of the 9,28%, much more than the 6% of the wooden products, so that the pruning had a good calorific value: 4007 kcal/kg.

The nitrogen value was 1,12%, as the other biomasses.

Not easy the evaluation of the influence of the nitrogen oxides “fuel”, because the most share remains in the “thermal”, that originate from the large air excess utilized in combustion.

As the other wooden product, was very low the value of the Si (21,9 mg/kg), instead, was remarkable the K value (10.365) mg/kg, important for the ashes melting point.

Table 2. Olive pruning chemical composition

Parameters	Unit	Results
Humidity at 105 °C	%	12,0
Low calorific value	Kcal/kg	4.007
C	%	41,2
H	%	9,28
N	%	1,12
S	%	0,02
Si	mg/kg	21,9
Al	mg/kg	57,9
Fe	mg/kg	59,8
Ca	mg/kg	11.145
Mg	mg/kg	371
Na	mg/kg	75,7
K	mg/kg	10.365
Ti	mg/kg	1,1
P	mg/kg	1.276



Figure 2. Fuel sample

In this way are good the values of the Ca (11.145 mg/kg) and of the Mg (371 mg/kg).

Though these values, the ashes melting point was of 975°C, very good for thermic use in each kind of boiler, lower than the biomass standard values, usually characterized from a good performance at high temperatures.

The value of the Fe (59,8 mg/kg), Al (57,9 mg/kg) and Ti (1,1 mg/kg), were very low compare to forestry long rotation turn wood.

The complete absence of Cl and chloride and the concentration of S (0,02%), don't have to give problems of acid.

TESTS RESULTS

Combustion phase and emissions analysis.

The boiler has been considered at speed after half hour of function.

Values of the gases (such as CO or NOx) aren't been registered very high not even in the first phase of the test.

After few minutes from the start, the carbon monoxide was already under the 1.000 mg/Nm³, to reach slowly stables values.

The most important data are reported in tab. 3.

Table 3. Test data

Parameters	Unit	Results
Emission height	m	5
Relief height	m	1,5
Emission section	m ²	0,096
Emission temperature	°C	85
Flow speed	m/s	4,9
Real flow	m ³ /h	1.693
Normal flow	Nm ³ /h	1.291
Furnace temperature	°C	94

The flow at the chimney was of 1.693 m³/h (normalized 1.291 Nm³/h) with a speed of 4,9 m/s.

The smoke temperature was only 85 °C.



Figure 3. The boiler's furnace

This value is so low not only for the heat exchanger, an hot air fan of 18.000 m³/h, but especially for the very low temperature in the furnace, only 94 °C, due to the high air excess ($e = 11,297$) of the secondary air.

In fact the chimney smoke presented 19,3% of oxygen, that well explains the high flow of fresh air utilized for the combustion.

Thus NO_x value, 511 mg/Nm³ (with O₂ at 11%) was positively influenced.

Carbon monoxide was 718 mg/Nm³ (O₂ at 11%), that's surely a good value for the low temperature of the furnace.

An Excel sheet was implemented to evaluate mass balance.

So has been possible to make a simulation of the stationary conditions of combustion.

The following code gave the efficiency of combustion and the mass and volumetric balance of the air and of the fuel before and after the combustion.

The sheet has been planned on the generic reaction:

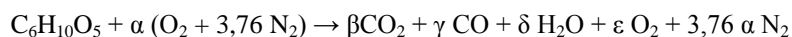

Known the value of the CO and of the O₂, has been possible find the β, ε and, as difference, the value of γ. The furnace appears on the reaction:

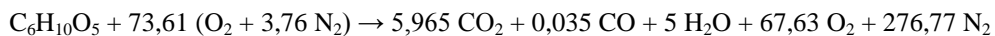

That gives a good evaluation of the combustion process.

We neglect the parameters of low interest and the formation of the NOx.

In tab. 4 are shown the values obtained at the chimney.

Table 4. Emissions analysis

Parameter	Relief value	Law limit	Mass flow
Dust	19,7 mg/Nmc	50 mg/Nmc	25,4 g/h
SOV	25 mg/Nmc	50 mg/Nmc	32,3 g/h
NOx	511 mg/Nmc	650 mg/Nmc	659,7 g/h
SOx	absent	2.000 mg/Nmc	-
Fluoride	0,17 mg/Nmc		
Chloride	0,06 mg/Nmc		
Nitrate	0,09 mg/Nmc		
CO	718 mg/Nmc	-	927 g/h
O ₂	19,3 %	-	-

Ashes analysis

Ashes residue was 3,9% at 600 °C (tab.5).

Table 5. Ashes analysis

Parameter	Unit	Relief value
P ₂ O ₅	%	6,98
Chloride	%	< 0,005
Si Oxide	%	0,03
Al Oxide	%	0,47
Fe Oxide	%	0,22
Ca Oxide	%	41,6
Mg Oxide	%	2,35
Na Oxide	%	0,41
K Oxide	%	32,8
Ti Oxide	%	0,01
Melting point	°C	975

There aren't values of particular importance but, as we expected, the K oxide are 32,8%, share that, as shown, is important for the melting point.

At the opposite there is the Ca oxide with 41,6%.

Thermodinamic plant performance.

The thermic energy produced is utilized to heat a civil user and a gym by an air fan, with a nominal flow of 18.000 m³/h.

For the short and particular shape at S of the air pipe, it wasn't possible to find the real plant flow with an acceptable error so, for the evaluation further reported was considered the nominal value.

Table 6. Border data

Parameter	Temperature / °C
Outdoor air	24,4
Boiler room	23,6
User	25,0
Going water	60
Back water	37
Fan air	34
Boiler shell	26 – 27,5
Boiler door	51,8 – 53,1
Smoke	85

Table 7. Thermotechnics performance

Parameter	Unit	Thermic power
Fuel power	kcal/h	71.124
Process water power	kcal/h	49.250
User available power	kcal/h	48.108
Unburned losses	kcal/h	241
Ashes losses	kcal/h	384
Boiler shell losses	kcal/h	595
Smoke losses	kcal/h	20.654

For our test has been used only the fan, with an exchanger air-water heating the gym and for the short test period and the gym volume, we'll consider the user as a well at 25 °C.

The condition of the test are shown in tab. 6. The thermic performance are reported in tab. 7.

Environmental performance.

Last years a project financed from the European Community has been concluded.

It wanted evaluate the external cost in our society due to transport, civil and energy.

Using the achievements of this project, called Externé, and the values of the emissions of the different fuels, we'll offer an estimation of the environmental impact of each parameter of interest.

We'll try to estimate the environmental impact from the values obtained at the chimney.

We compare the biomass cycle with others boilers that use fossil fuel showing the pollution. The values are shown in fig. 4.

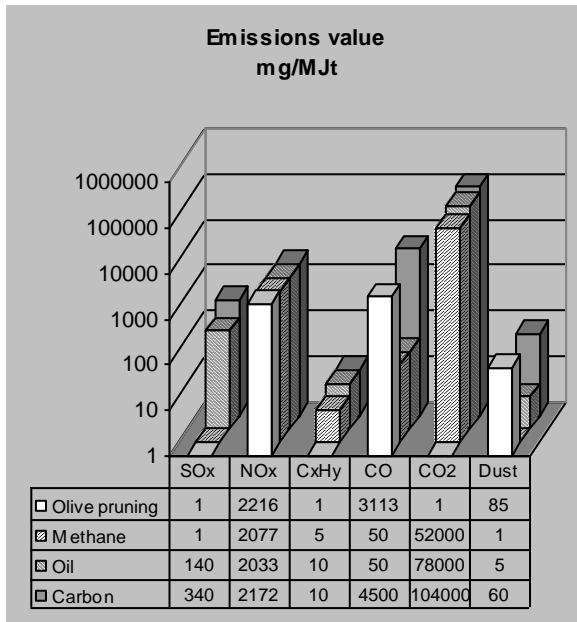

Figure 4. Emissions analysis

CONCLUSION

Economically, heating with pruning instead LPG seems to save about 40% of the heating cost especially when pruning are self produced.

The thermic efficiency was 67,65%, that is very good considering the low power utilized (70.000 instead of 400.000 kcal) of the boiler and the high outdoor temperature.

In fig. 5 the performance of the boiler, the percentage useful and lost are reported.

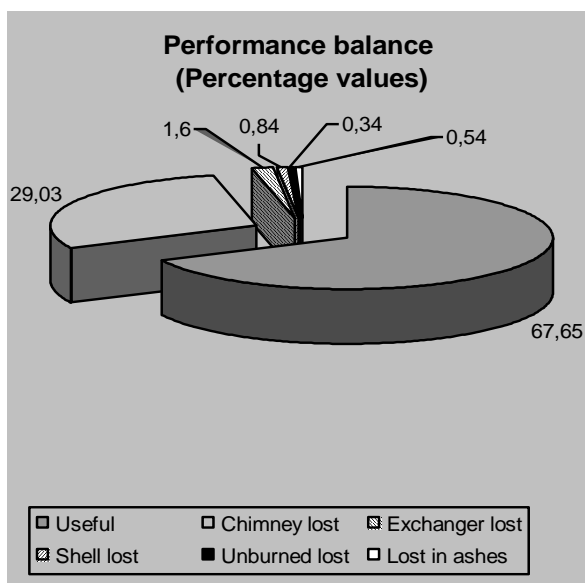

Figure 5. Efficiency analysis

Then, using the Externe methodology the environmental cost was evaluated and the result has some surprise.

Fig. 6 shows as the share of damage of the CO₂, strongly penalizing the power generation plant, is soothed from the high efficiency of the thermic cycles and doesn't seem to pay the damage of the CO, that is better for the methane and the oil.

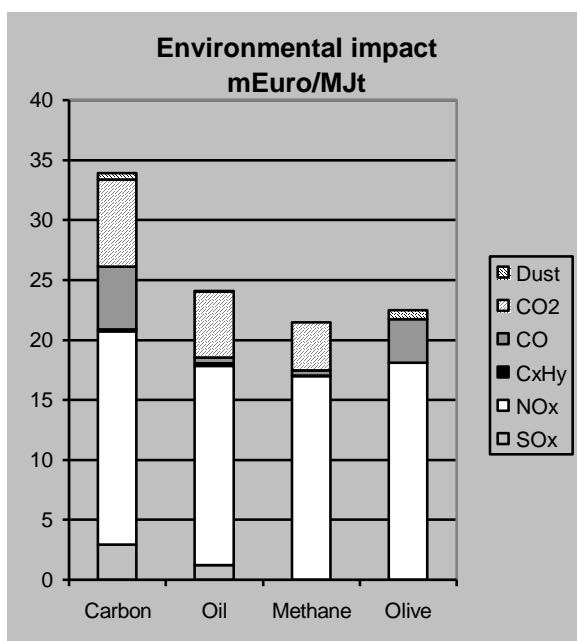

Figure 6. Environmental damage

Very high, also for the fossil fuel, the share of the NOx for the high excess of air.

Very low the relief of the dust.

In conclusion, the biomass plant seems to have an environmental impact between the methane and the oil plant and it seems that a little improvement is possible for the CO level with a better combustion.

REFERENCES

1. BABIC L., BABIC M. (1999): "The kinetic of prismatic straw bale combustion"; Energy and Agriculture towards the Third Millennium – Athens, Greece, 2-5 June 1999
2. LARS N. (1988): Straw for Energy Production; Danish Energy Agency, 1998
3. LOZZA G. (1997): Turbine a gas e cicli combinati; ed. Progetto Leonardo
4. Energy from biomass: Thermochemical conversion, Gent, Belgium, 29 – 31 October 1991
5. European Commission DGXII Externe, Externalities of Energy (1995)
6. CUTINI M. (2000): Analisi ed ottimizzazione dei costi ambientali dei sistemi di generazione di potenza,



FIRST TEST ON PRUNING HARVESTING

LUIGI PARI, MAURIZIO CUTINI

ISMA (Istituto Sperimentale per la Meccanizzazione Agricola)
Rome, Italy

SUMMARY

Agriculture is probably the main biomass producer in Italy, basically made of pruning coming out from fruit and citrus orchards, vineyards and olive grounds. At present, most of this material is burned in open fields or ploughed down into the soil. This because there is no market for this biomass and there are no equipment able to harvest it at low costs. The paper briefly shows the result of an experimentation in the South of Italy, aiming at agricultural prunings collection (from peach, vine grape and olive trees). Several machines were tested (based on on-field chipping and on-field compacting) and proper adjustments were suggested to the manufacturers, in order to keep costs as low as possible. Some remarks about biomass sustainable supply costs are reported as conclusions.

Key words: *pruning harvest mechanisation, biomass cost*

INTRODUCTION

Power plants of 10-20 MWe, need biomass with specific physical and chemical characteristics. There are two main sources of biomass affecting plants' technology and related investments: cellulose or ligneous.

There are several biomass sources all over Italy, ranging from straw to forest residues, agricultural residues and waste wood. In Italy, the emission limits and the content in chlorine make straw power plants be considered as less attractive than woody ones, while the most of waste and urban wood is used in panelboard industry.

Main EU biomass producer is agriculture. Fruit, olive and grape trees pruning are produced every year in a large amount, but this kind of biomass is actually burned at the orchard border or ploughed down into the soil.

The first step in order to let farmers be involved in biomass energy business is to give them equipment suitable to collect pruning at low cost.

In order to evaluate the effectiveness of pruning residues utilization for energy production, the Italian Ministry of Agriculture and the European Union have financed the following research: “Study for the energetic valorization of pruning residues in Calabria and Sicily Regions” in the frame of Multiregional Operative Programme – Activities of Support to the Services for Agriculture”.

ORCHARDS CHARACTERISTICS

Equipment was tested in peach orchards, vineyards and olive groves.

In Southern Italy, peach and grape vine grow respectively as Y training system and trellised vines. These training systems affect the maximum machines height, length and width. A statistical evaluation of the useful space inside the orchards was done (Table I and Figures 1 and 2). Nevertheless, peach is trained as palmetta too.

Table I. Plant distance and useful space for machines.

	Plant distance (m)	Max useful height (m)	Space for machines (m)
Trellised vines	2.5 x 2.5	1.8	1.7 x 1.2
Trellised vines	3.0 x 3.0	1.8	1.7 x 1.2
Y training peach	4.5 x 1.5	3.0	2.0 x 1.5

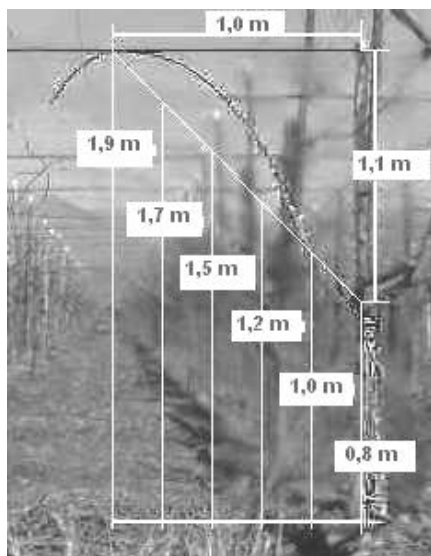

Figure 1. spaces into trellised vines

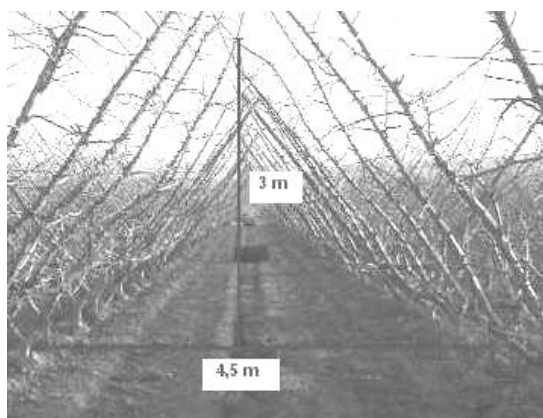

Figure 2. spaces in Y training peach

On the contrary, in olive grounds the restricting issue is not equipment size (the distance between trees of over 8 m), but the branch size. Olive trees are generally around 100 years old. Even if workers generally take out the wood of 50-80 mm in diameter for household use, the diameter and the length of branches affect the mechanisation of pruning collection.

Biomass yields varies with species and training system (Table II). The summer pruning is very widespread all over the South of Italy and effect very much the yield of wood obtained in winter from peach and grape wine, if compared to the one of 4-5 t/ha obtained in Northern Italy. Water shoot removal, two leaf removal and a heavy summer pruning were done on trellised vines, while three summer prunings were done on Y training system peach. Only a summer pruning was done on Palmetta peach, while one severe pruning after five years was done on olive trees.

Table II. yield in fresh biomass

	Density (trees/ha)	Age (years)	Yield (t/ha)	Moisture (% w.b.)
Trellised vines	1,601	6	3.7	50.2
Trellised vines	1,112	12	2.6	50.4
Y peach	1,482	6	1.3	44.6
Palmetta peach	741	12	4.8	44.2
Palmetta peach	889	7	4.8	44.6
Olive ground	139	150	19.0	41.3

MATERIALS AND METHODS

Generally speaking, two techniques can be applied for pruning harvesting: on-field chipping and on-field compacting. The former generally derives from common shredders, adjusted for the on-field management of the biomass. The latter derives from forages equipment (square and round balers machine).

As for balers machine, we adapted existing standard models and we used specific prototype as well.

On-field chipping and on-field compacting are subsidiary. The physical characteristics of the final product affect the next steps of the biomass energy chain: storage, transport and management inside the power plant.

Both methods were tested and, on the basis of the obtained results, some equipment producers are going to adjust their machines in order to optimise performances.

As for on-field chipping, two OMARV machines were tested: the TE 140 R and the TR 190 (Figure 3 and 4). Their technical characteristics are shown in Table III. They are based on a hammer-mill rotor which aims at crushing and creating the air flow for biomass transfer to the loading bin. When the loading bin is full, biomass is unloaded into a trail.

The two models change in working width (respectively 1.60 m and 2,35 m) and in loading bin capacity (respectively 2,70 m³ and 6,50 m³).



Figure 3. OMARV TE 140 R



Figure 4. Arbor RS 170

Table III. OMARV machines' technical characteristics

	Unit	TE 140 R	TR 190
Size:			
- width	m	1.60	2.35
- height	m	0.80	
- length	m	1.10	
Weight	kg	410	2,480
Minimum power	kW	30	40
Rotor diameter	m	325	325
Hammer-mill	n°	24	32
Bin capacity	m ³	2.7	6.5
Height of unload	m	2.0	2.6

The TE 140 R worked on trellised vines. Working capacity is about 0.45 hectares/hour. Thus, hourly production is 1.2 tons/hour. Time needed for bin unloading is 40% of the total. Biomass is, in theory, ready to be burned.

The TR 190 performances in peach orchard is very different if compared to olive ground. On peach we obtained 0.8 hectares/hour. The 3.7 tons/hour of hourly production are in general terms interesting, while time used for the bin unload is 15% of the total.

Due the multi-year pruning, the higher yield per hectare and the higher diameter of wood, working speed in olive grounds is really lower. But, even if working capacity is only of 0.25 hectares/hour, the high amount of processed biomass (around 19 tons/hectare) takes hourly production up to 4.7 tons/hour.

So, the amount of biomass on the ground plays a key role in machines performance.

TESTS RESULTS

In these trials, compacting interested only baling. On palmetta training system (peach) a Welger RP 320 was tested (Table IV). The machine is provided with a rotary feeder and knives, but only three knives were left in order to help branches enter the baler' compression chamber. Capacity is 0.5 hectares/hour (waste times included), even if effective capacity (no waste time considered) is 1.2 hectares/hour. Production is 2,4 tons/hour: the orchard structure affects the machine performances very much. Anyway, a roller roundbaler provided with a rotary feeder properly adjusted is interesting, even if farmers have to consider the bales (1.2-1.5 m in diameter) compatibility respect the plant chipping equipment.

Table IV. Welger RP 320 technical characteristics

	Unit	Value
Size:		
- width	m	2.48
- height	m	2.70
- length	m	4.75
Weight	kg	3,260
Minimum power	kW	33
Bale diameter	m	1.5
Bale width	m	1.2
Pick-up width	m	2.25
Height of unload	m	2.0

In olive grounds the point is different: even if working capacity is 0.2 hectares/hour and, due to the high yield in biomass, the hourly production is 2.3 tons/hour, a common

roundbaler is not to be trusted for olive pruning collection. This because mechanical stress resistance: in the South of Italy and in real operations, wood length and diameter causes frequent pick-up breaking-off. We were not able to check damages on transmissions.

The other tested roundbaler is Arbor RS 170, produced by the TiGiEffe (Italy). It is a prototype prepared for Northern Italy viticulture conditions. It has some specific characteristics that, with some adjustments, make it interesting for Southern Italy operations and matches energy industry needs.

Arbor RS 170 is a small roundbaler (2.10 m long, 1.70 m large and 1.40 m high; Figure 4 and Table V) very suitable for pruning harvesting where training systems have few space for equipment operation.

Table V. Arbor RS 170 technical characteristics

	Unit	Value
Bale diameter	m	0.50
Bale width	m	1.00
Pick-up width	m	1.30
Minimum power	kW	25
Size:		
- length	m	2.10
- width	m	1.67
- height	m	1.40
Weight	kg	760

This machine was tried on trellised vines and on Y training system peach. More interesting results were obtained on vine grapes, where we obtained 0.2 hectares/hour and 0.7 tons/hour. These values are very low compared to the ones obtained in Northern Italy. Anyway they are acceptable for household biomass use. On the base of the these trials, the manufacturer has already begun to apply the proper adjustments, in order to make this machine useful in Southern Italy too, in the frame of the industrial energy use of prunings.

Table VI and Table VII show performances of tested equipment.

Table VI. speed and capacity of the tested equipment

	Machine	Real speed (km/h)	Capacity (ha/h)
Trellised vines	Omarv 140	2.29	0.44
Palmetta peach	Omarv 190	1.52	0.77
Olive ground	Omarv 190	0.56	0.25
Palmetta peach	Welger	5.01	0.50
Olive ground	Welger	1.80	0.19
Trellised vines	Arbor	1.31	0.20
Y peach	Arbor	2.34	0.42

Table VII. productivity of the tested equipment

	Machine	Biomass losses (tons/ha)	Hourly production (t/h)
Trellised vines	Omarv 140	1.34	1.2
Palmetta peach	Omarv 190	1.32	3.7
Olive ground	Omarv 190	0.16	4.7
Palmetta peach	Welger	1.43	2.4
Olive ground	Welger	n.d.	2.3
Trellised vines	Arbor	1.43	0.7
Y peach	Arbor	0.99	0.5

BIOMASS COST: THE INDUSTRY POINT OF VIEW

Pruning harvesting costs are different in each country and, inside this, in each local scenario. For this reason, instead of a bare calculation of the costs based on the situations we operated on, we prefer to give some guidelines about the industry point of view.

To get a good economic yield, biomass cost cannot be higher than a certain limit.

In fact, the biomass supply costs that energy use can sustain depend on:

- social environment of the plant site;
- power and heat price;
- investments.

As regards the first point, we can underline that, especially when a public institution is a partner of the plant management company, biomass sources with higher cost could be

selected. In fact, among the targets of a public institution there are job creation, environment maintenance and other social issues. These situations can justify the use of more expensive biomass sources.

Power and heat prices are settled in different way in each country. In Italy, in the near past biomass power price was around 0.150 Euro/kWh. In the near future, biomass power price will be free and settled by market laws. So, heat use will be very important to get good economic results in the plant management.

Investments level changes with the technology (basically imposed by emission limits) and the plant size. Increasing plant's size, the specific investment is low, but development cost are higher. Moreover, biomass supply and bureaucratic process are more complicated.

Especially in the free market of biomass power, public grants are very important for plant feasibility.

In conclusion, each plant has its characteristics and can sustain his own biomass supply cost.

RESULTS AND CONCLUSIONS

Pruning harvest mechanisation is a new interesting market for agricultural equipment. There are several solutions proposed by machines manufacturers. Anyway, further experimentation is needed, in order to get the technical maturity able to low the costs. In fact, operative conditions affect very much performances of machines. That means that biomass costs are not interesting for energy industry needs. For instance, the collection of pruning in large volume and high size is still not optimised, as olive pruning in the south of Italy. So, the cooperation between the several actors (manufacturers, farmers and biomass energy industry) is the main issue for the development of this sector.

This research is the first step and allows:

- farmers to have the technical know-how to get more income and use by-products actually burned or ploughed down (if residues are ploughed down, they have a high cost and pests/fertility troubles);
- equipment producers to have new products to be proposed in the saturated market of agricultural equipment;
- energy industry to get good quality fuel at good price;
- EU energy policy to have tools to increase the use of renewable energy sources.



EKSPLOATACIJSKE KARAKTERISTIKE SITNILICE DRVNOG ODPADA CHROMCOM

TOMAŽ POJE

Kmetijski inštitut Slovenije
Oddelek za kmetijsko tehniko
Ljubljana, Slovenija

SAŽETAK

Kod sitnilice drvnog otpada Chromcom Lignatec Z190 ustanovljena je potrebna snaga za pogon preko priključnog vratila. Mjerenjem zakretnog momenta i broja okretaja na priključnom vratilu izračunata je potrebna snaga za pogon neopterećene sitnilice i za pogon različito opterećene sitnilice. Ustanovljeno je, da je maksimalno potrebna snaga na priključnom vratilu 34,5 kW. Razina buke je zavisna od opterećenja sitnilice i iznosi maksimalno 111,2 dB(A).

***Ključne riječi:** sitnilica drvnog otpada, zakretni moment, snaga za pogon, buka*

UVOD

Sitnilica drvnog otpada sječe (sitni) drvenu biomasu. Usitnjen materijal zovemo sječka. Ta se može upotrijebiti u različite svrhe: za kompost, za zastirku, koja čuva ukrasne rastline pred korovima i pred prevelikim osušenjem tla. Takva zastirka upotrebljava se i za čuvanje tla pred vodenom erozijom (odnošenjem tla). Kod čišćenja komunalnih površina bolje se iskoristi volumen prikolica sa kojima se sječku odvozi. Drvna sječka može se koristiti i kao gorivo u specijalnim pećima, što se sada najviše koristi u Austriji, a uvodi i u Sloveniji. Izvor drvene mase su šume, poljoprivredne i urbane (komunalne) površine. Prema radu, sitnilice drvnog otpada su slične silokombajnima ali su građene robustnije. Poznati su različiti radni elementi (bubanj, disk, puž). Sitnilice mogu biti kao traktorski priključak, nošen ili vučen, dok pogon dobivaju preko priključnog vratila traktora. A mogu biti i sitnilice sa vlastitim pogonom (motorom) na nekom podvozju. Male se pune sa drvom ručno, dok veće sa utovarivačem, koji može biti montiran na sitnilicu ili pak samostalan.

U svrhu uvođenja takvih strojeva i postupaka kao i potrebe proizvođača izveli smo neka eksploatacijska ispitivanja sitnilica, koje se proizvode u Sloveniji.

METODIKA ISTRAŽIVANJA

Za određivanje eksploatacijskih karakteristika sitnilice drvnog otpada upotrijebili smo sitnilicu slovenskog proizvođača Chromcom Lignatec Z190, koji ima pogon preko priključnog vratila traktora. Debljina drva koje se sjecka može biti do 190 mm. Lijevak je širok 1150 mm i visok 900 mm. Širina valjaka za dovođenje je 260 mm, a pogon mu je pomoću hidromotora. Ugrađenu ima elektronsku regulaciju pogona valjaka za dovođenje (kod preopterećenja se valjci za dovođenje automatski okreću unazad). Radni element - disk sa dva noža okreće se sa brzinom 1000 okretaja na minut. Veličina sječke regulira se sa brzinom vrtnje valjka za dovođenje (pomoću proporcionalnog ventila) i iznosi od 0,4 do 2 cm. Izlazna cijev okreće se za 360 stupnjeva.

Za pogon sitnilice Chromcom upotrijebljen je traktor snage motora 100 kW.

Tabela 1: Glavni tehnički podaci za sitnilicu drvnog otpada Chromcom Lignatec Z190

Table 1: Major technical data for the wood chipping machine Chromcom Lignatec Z190

Model	LIGNATEC Z190
Širina	1,42 m
Dužina	2,35 m (2,07 m sa zatvorenim lijevkom)
Promjer ulaznog materijala	190 mm
Dužina dodavajućih valjaka	260 mm
Dimenzije lijevaka	1150 x 900 mm
Debljina sječke	0,4 – 2 cm
Okretaji priključnog vratila	1000 okr./min
Promjer diska sa noževima	800 mm
Debljina diska	30 mm
Broj noževa	2
Visina izlazne cijevi	2,54 m
Izlazna cijev okretljiva za	360 stupnjeva
Težina stroja	850 kg
Pogon	Preko priključnog vratila



Slika 1: Sitnilica Chromcom Lignatec Z190 nošene je izvedbe, a pogon ima preko priključnog vratila traktora

Figure 1: Mounted wood chipping machine Chromcom Lignatec Z190 is driven by the PTO

Mjerene veličine:

Zakretni moment na priključnom vratilu.

Broj okretaja priključnog vratila

Proračun:

Iz rezultata mjerenja izračunata je snaga za pogon iz jednadžbe (1).

Snaga za pogon:

$$P_p = M\omega \quad (1)$$

$$P_p = M\pi \frac{n}{30} \quad (2)$$

Značenje oznaka:

P_p - potrebna snaga za pogon priključaka preko priključnog vratila, W

M - zakretni moment na priključnom vratilu, Nm

ω – kutna brzina, rad

n - broj okretaja priključnog vratila, min^{-1}

Mjerni sustav

Mjerni sustav sastavljen je iz tri dijela: a) davač (senzor), b) mjerno pojačalo, c) PC računalo. Frekvencija uzimanja podataka bila je 10 Hz.

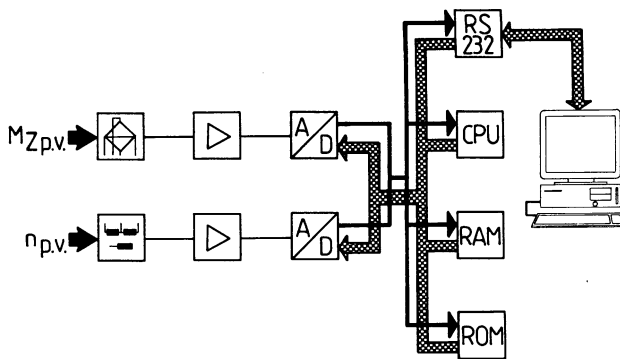

Slika 2: Shema mjernog sustava

Figure 2: Scheme of measurement system

REZULTATI I DISKUSIJA

Sitnilica drvnog otpada Chromcom Lignatec Z190 bila je agregatirana sa traktorom snage 100 kW (136 KS). Za pogon sitnilice upotrebjeno je priključno vratilo sa 1000 okretaja na minut. Sitnili smo grane i stabla graba, koji ima vrlo tvrdo drvo.

Potrebna snaga za pogon sitnilice drvnog otpada

Kod sitnilice drvnog otpada mjerili smo zakretni moment i broj okretaja priključnog vratila. Mjerenja smo izveli kod rada sitnilice bez opterećenja i sa opterećenjem (sa drvnom

masom). Na osnovi izmerjenog momenta i broja okretaja na priključnom vratilu izračunata je potrebna snaga za pogon sitnilice bez opterećenja i sa opterećenjem.

Kod pogona sitnilice Chromcom bez opterećenja bio je na priključnom vratilu izmjeren prosječni moment 29,7 Nm, dok je maksimalni iznosio 42,8 Nm. Izračunata prosječna snaga za pogon sitnilice iznosila je kod neopterećene sitnilice 3,089 kW. Maksimalna potrebna snaga za pogon neopterećene sitnilice bila je 4,467 kW. Prosječni okretaji priključnog vratila bili su 993 okr./min.

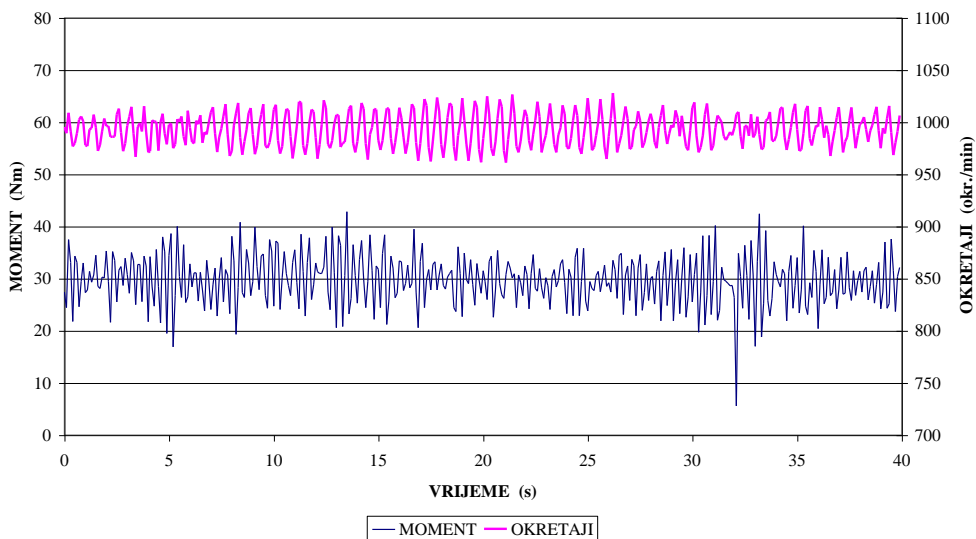

Slika 3: Moment i broji okretaja priključnog vratila traktora kada sitnilica nije bila opterećena. Mjerenje je bilo dugo 40 s.

Figure 3: The measured torque and number of revolutions of the shaft of the unloaded wood chipping machine. Measurement lasted 40 seconds.

Izmjereni moment i izračunata potrebna snaga za pogon sitnilice vrlo je zavisna od njenog opterećenja. Na slikama 5 i 6 vrlo se dobro vidi porast momenta kod dodavanja različito debelog drva u stroj. Na slici 5 prikazan je tok zakretnog momenta kod dodavanja (sitnjenja) grana graba, dok je na slici 6 izmjereni moment kod sitnjenja debelih stabala graba. Zbog velikog opterećenja istovremeno se javlja smanjenje broja okretaja priključnog vratila (aktivira se naprava za preopterećenje).

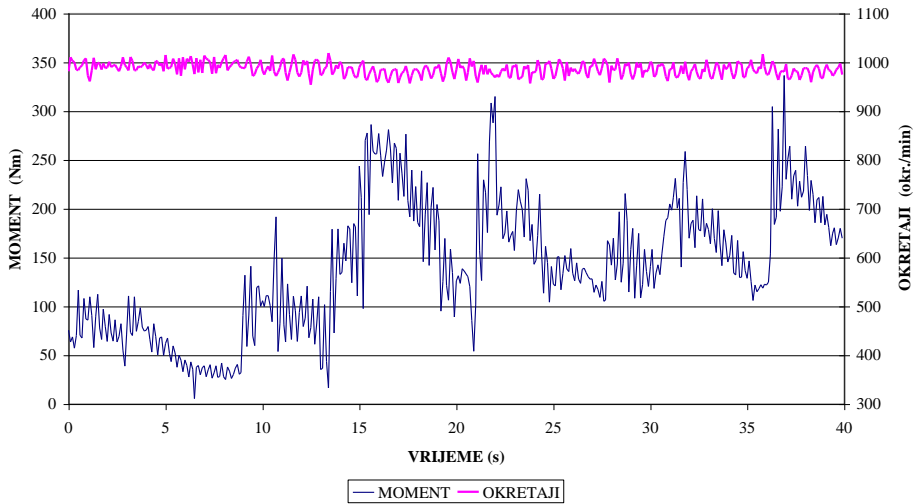

Slika 5: Izmerjeni zakretni moment i broji okretaja na priključnom vratilu traktora, kad smo sitnili grane graba

Figure 5: The measured torque and number of revolutions of the shaft when the machine was used to chip the branches of the beech tree.

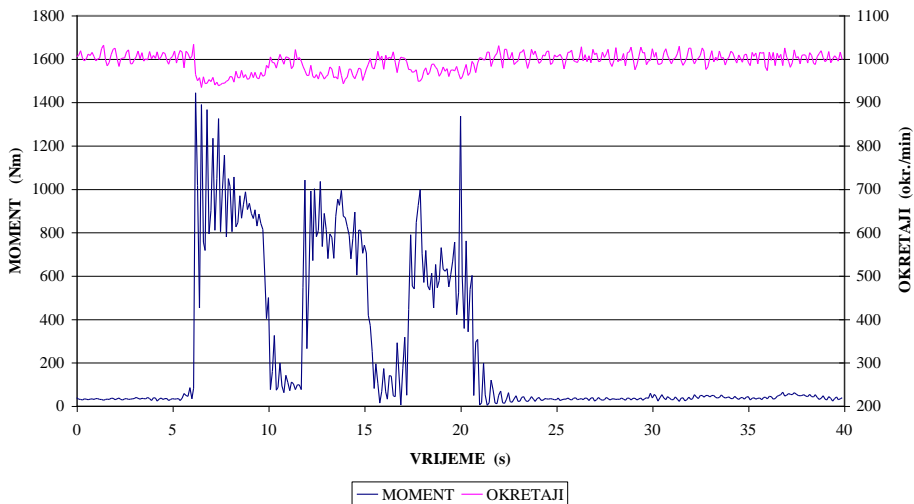

Slika 6: Izmerjeni moment i broji okretaja priključnog vratila kad smo u sitnilicu dodavali stabla graba

Figure 6: The measured torque and number of revolutions of the shaft when the machine was used to chip the trunk of the beech tree.

Slika 7 prikazuje potrebnu snagu kod neopterećene sitnilice i kod opterećene sitnilice sa nekom proječnom biomasom (granama) graba. Prosječna potrebna snaga bila je kod sjeckanja 14,4 kW, dok je maksimalna bila 34,5 kW.

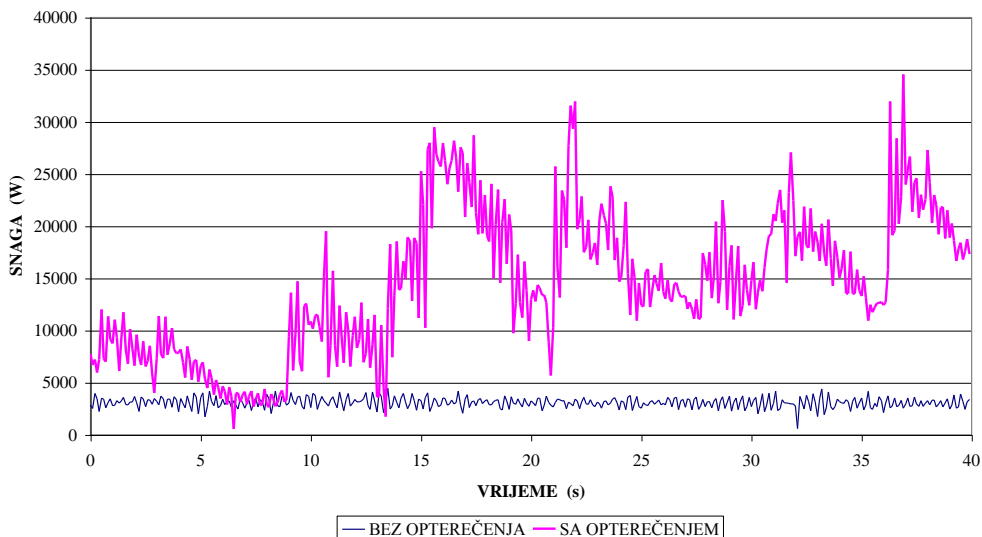

Slika 7: Angažirana snaga na priključnom vratilu traktora za pogon sitnilice sa i bez opterećenja. Mjerenje je trajalo 40 s.

Figure 7: Engaged power on the PTO for driving of the unloaded and loaded wood-chipping machine. Measurement lasted 40 seconds.

Poslije sitnjenja izmjerili smu vlagu i dužinu sječke, koja se inače može podešavati. Drvna sječka imala je 42,4 % vlage, dok je njena prosječna dužina iznosila 15,8 mm.

Razina buke

Kod rada sa sitnilicom radnik je izložen buci, zbok koje je normalno da je zaštićen sa štitnicima za uši. Razina buke je zavisna o opterećenju sitnilice. Kod rukovatelja sitnilice izmjerili smo kod neopterećene sitnilice 85,8 dB(A), kod sitnjenja grana izmjerena je buka od 105 do 107 dB(A), a najviša razina buke bila je 111,2 dB(A) kod najvećeg opterećenja.

ZAKLJUČAK

Sitnilice drvnog otpada značajne su u komunalnoj djelatnosti a u zadnje vrijeme pridobivaju vrijednost kao strojevi za pripremu sječke u energetske svrhe. Zbog nedostatka tehničkih i eksploatacijskih karakteristika izveli smo određena ispitivanja domaćih sitnilica. Ustanovili smo, da je potrebna snaga za pogon sitnilice Chromcom preko priključnog vratila traktora zavisna od vrste i debljine ulaznog drva. Kod naših mjerenja ustanovili smo, da je maksimalna potrebna snaga za pogon 34,5 kW, dok maksimalna buka iznosi 111,2 dB(A).

LITERATURA

1. DOLENŠEK M., (1999) Sekalniki. Energija iz lesne biomase, Kmetovalčev priročnik, Kmetijska založba Slovenj Gradec, s. 22 - 25
2. KRAJNC N., DOLENŠEK M., (2001) Sodobna raba lesne biomase (potenciali in tehnologije). Zbornik simpozija Trendi v razvoju kmetijske tehnike, Radenci 14.-15.6.2001, Društvo kmetijske tehnike Slovenije, s. 113 - 121
3. POJE T. (2000) Sekalnik Tehnos 14/22 TR. Tehnika in Narava, IV, 4, ČZD Kmečki glas, s. 15 - 17
4. POJE T. (2001) Sekalnik Chromcom Lignatec Z190. Tehnika in Narava, V, 2, ČZD Kmečki glas, s. 13 - 14
5.Navodila za uporabo Chromcom Lignatec

EXPLOITATION CHARACTERISTICS OF CHROMCOM WOOD CHIPPING MACHINE

SUMMARY

Engaged power required for the driving of the wood-chipping machine by PTO is described. Measurements of the torque and the number of revolutions at the shaft for the driving of the unloaded and loaded wood-chipping machine were carried out. The results were used to calculate the machine power. It was found that the maximal engaged power that is necessary for driving equals 34,5 kW. The level of noise that depends on the load level of the machine peaked at 111.2 dB(A).

Key words: wood chipping machine, torque, power, noise

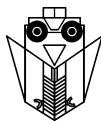

PROBLEMATIKA ODRŽAVANJA PLODNOSTI TLA U VOĆNJAKU

STJEPAN SITO, JOSIP BARČIĆ, GORAN FABIJANIĆ

Agronomski fakultet
Zavod za mehanizaciju poljoprivrede
Zagreb, Hrvatska

SAŽETAK

Kao posljedica neprimjerenog načina održavanja tla je narušavanje strukture tla, pojačan gubitak organske tvari-humusa u tlu, izražena pojava erozije, gubici hranjivih tvari iz tla, zbijanje površinskog sloja, smanjena životna aktivnost u tlu (mikroorganizmi), pojačan gubitak vode iz tla, smanjena izmjena plinova u zoni korijenovog sustava, slab porast, neredovita rodnost, nerazvijenost korijenovog sustava, povećana sklonost prema bolestima (posebno gljivične), pojačana osjetljivost na kasnoproljetne mrazeve i dr. Ovakvo stanje u voćnjaku izravno utječe na povećanje troškova za zaštitu i gnojidbu, slabu iskorištenost mehanizacije, smanjenje prirodne kvalitete plodova, odnosno na značajno umanjenje ekonomičnosti proizvodnje voćnjaka.

Ključne riječi: voćnjak, održavanje tla, plodnost, oborine

UVOD

Pod pojmom "održavanje" tla podrazumijeva se primjena različitih agrotehničkih mjera u voćnjaku koji utječu na biološka, kemijska i fizikalna svojstva tla, odnosno na plodnost tla.

Sve do nedavno kod nas, a i u Europi, tlo u voćnjacima se uglavnom održavalo klasičnom obradom, korištenjem plugova, tanjurača ili rovilica-freza. Danas s ekološkog aspekta održavanje tla treba omogućiti povećanje plodnosti tla. Pored neophodnih zahvata strojevima, prisutno je zastiranje organskim tvarima i uzgoj kultura u međuredovima voćnjaka za zelenu gnojidbu (Bauer, 1996). U suvremenom održavanju voćnjaka može se kombinirati organska i mineralna gnojidba, uz povremenu primjenu herbicida. Kombiniranim načinima održavanja tla u voćnjacima izravno se utječe na biološka,

kemijska i fizikalna svojstva tla. Već prema načinu održavanja tla djelovanje na tlo može biti pozitivno ili negativno.

U kontinentalnom dijelu Hrvatske u voćnjacima na malim poljoprivrednim obiteljskim gospodarstvima se najčešće primjenjuje permanentna obrada tla oranjem a često i rotirajućim oruđima (rovilicama), što je rezultiralo određenim nedostacima. Optimalan sustav održavanja tla u voćnjaku treba djelovati na: povećanja i čuvanje organske tvari u tlu (humusa), kojeg bi u površinskom sloju trebalo biti između 1,5-4,0 %, uravnoteženje toplinskih i vodozračnih odnosa u tlu. Nadalje, treba onemogućiti eroziju čestica tla, poboljšati opskrbu hranjivima i povećati kapacitet tla za vodu, izbjeći izravno djelovanje sunca na tlo i gubitak hranjivih tvari (posebno dušika) tijekom cijele godine, omogućiti odgovarajuću mobilnost i dostupnost hranjivih tvari u važnim fazama vegetacije biljke, te dobru prohodnost strojeva tijekom zaštite voćnjaka i drugih operacija, stvoriti optimalne uvjete za život tla (makro i mikroorganizmi), omogućiti razvoj raznovrsne flore odnosno faune tla (raznovrsnost biljaka i insekata) i regulaciju korova, izbjeći efekt monokulture, popravljavanje i zadržavanje strukture tla, uključivanje i pospješivanje raznovrsja (raznolikost biljnih vrsti, sorti) i stabilizaciju ekosistema u voćnjaku (Sinclair i Gardner, 2001., Strauss i Novak, 1998). Pri optimalnom održavanju tla u voćnjaku neophodno je različite postupke održavanja međusobno uskladiti. Mehanička obrada tla, zatravnjivanje, zastiranje tla organskim ostacima i gnojidba se moraju međusobno dopunjavati. Negativni utjecaji na tlo moraju se čim prije otkloniti (zbijenost tla, česti prohodni strojevima, obrada u nepovoljnim uvjetima tla, primjena zaštitnih sredstava i dr.), jer narušavaju (ugrožavaju) život u tlu (M. Estler i H. Knittel, 1996).

PROBLEMATIKA

Kombiniranim sustavima održavanja plodnosti tla u nasadu značajno se utječe na smanjenje antropološkog zbijanja tla a time i na očuvanje i poboljšanje svojstava tla, naročito rizosfere, kao supstrata za uspješan uzgoj voćarskih kultura. Intenzivnim podizanjem malih voćnjaka na poljoprivrednim obiteljskim gospodarstvima unazad nekoliko godina teži se povećanju životnog standarda u područjima, gdje je poljoprivreda glavni poslodavac i izvor prihoda. Suvremena voćarska proizvodnja zahtjeva čitav niz specijalnih strojeva kojima se želi postići visoka proizvodnost rada i maksimalni mogući prirodni. Osnova suvremenog sistema intenzivnog uzgoja voćaka su stabla na nisko bujnim podlogama, koje omogućuju gusti sklop sadnje, raniji početak rodnosti i raniji dolazak u puni rod iz čega proizlazi veći početni prirod, a što skraćuje razdoblje investicijskog održavanja nasada i relativno brzo vraćanje uložениh sredstava. Način održavanja plodnosti tla ovisi od sorte i podloge, oblika krošnje i sistema uzgoja, tipa tla i reljefa, klime, vremenskih prilika i starosti nasada. U praksi se primjenjuju različiti načini održavanja tla: trajna obrada tla, obrada za privremenu sjetvu biljaka za zelenu gnojidbu, prirodno zatravljivanje u stanju ledine ili tratine, zatravljivanje s odabranim travama i leguminozama, malčiranje i nastiranje tla ispod voćaka, nastiranje tla neorganskim tvarima i uzgoj potkultura u voćnjaku. Optimalni sustav održavanja plodnosti tla u voćnjacima je kombinacija pojedinih, gore navedenih sustava, odnosno poželjno je primijeniti i zatravljivanje tla s djetelinsko-travnim i leguminoznim kulturama, koje putem bakterija razmnoženih na kvržicama korijenovog sustava vežu dušik, te tlo opskrbljuju dušikom

neophodnim za rast i rodost voćaka. U međuredu voćnjaka trava se intenzivno usitnjava strojem za usitnjavanje biljnih ostataka tzv. malčermom, a potom se brzo razgrađuje (uslijed intenzivne mikrobiološke aktivnosti) i ostaje na površini tla. Nedostatak ovog sustava su veći utrošak vode i hranjiva koje možemo izbjeći razvojem i primjenom posebnog stroja za površinsko prorahljivanje. Ovom agrotehničkom mjerom bi se sačuvala povoljna i popravila nepovoljna svojstva tla, te se osigurala poželjna rodost i visoka kvaliteta plodova.

Primjenom reduciranog načina održavanja tla, a s obzirom na agroekološke uvjete, cilj je poboljšati biološka, kemijska i fizikalna svojstva tla, radi postizanja optimalnih uvjeta za razvoj korijenovog sustava, te povećanja rodosti i kvalitete plodova. Smanjenjem broja prohoda strojevima između redova nasada značajnije umanjiti zbijenost tla. Zatravnjivanjem travno-leguminoznim kulturama nakon malčiranja umanjiti negativno djelovanje pneumatika stroja na tlo i omogućiti prohod strojevima nakon obilnih oborina (npr. zaštita). Uvođenjem reduciranog načina održavanja plodnosti tla umjesto permanentne (čiste) obrade, smanjiti troškove proizvodnje odnosno umanjiti upotrebu zaštitnih sredstava i mineralnog gnojiva, te na taj način povećati ekonomičnost voćnjaka.

Način održavanja tla u voćnjaku ovisi od sorte i podloge, oblika krošnje i sistema uzgoja, tipa tla i reljefa, klime, vremenskih prilika i starosti nasada. Zatravnjivanjem uz uzgoj travnih smjesa i leguminoznih kultura te primjenom površinskog prorahljivača postiglo bi se sljedeće; manji broj prohoda strojeva u voćnjaku, dobra prohodnost strojeva u međuredu nasada i u lošijim uvjetima tla nakon obilnih oborina (za potrebe tretiranja zaštitnim sredstvima i manipulacije tijekom berbe plodova), značajne uštede u obradi tla, manja sklonost voćaka bolestima i štetnicima, bolje iskorištenje već postojeće mehanizacije, izbjegnuta erozija čestica tla, intenzivna mikrobiološka aktivnost (koja je najveća na površini tla), poticanje raznovrsnosti bilja i insekata, umanjeno razvojem korovskih biljaka, poboljšani toplinski i vodozračni odnos u tlu, izbjegnuta pojava pokorice na površini tla, umanjeno izravno djelovanje sunca na tlo, i dr. Uvođenjem jesenskog uzgoja kultura za zelenu gnojidbu dobrim dijelom se može uštedjeti na mineralnim gnojivima i zaštitnim sredstvima i dr., te na taj način smanjiti troškove proizvodnje po jedinici proizvoda (npr. po kilogramu ploda).

U suvremenim intenzivnim voćnjacima, gdje padne godišnje preko 800 mm oborina s povoljnom raspodjelom tijekom vegetacije, tlo se u međurednim prostorima zatravnjuje travnim i leguminoznim kulturama. Međutim, ako su godišnje oborine manje neophodno je navodnjavanje. Sjetva djetelinsko-travnih smjesa se obavlja sijačicom u neobrađeno tlo voćnjaka, koje pomoću bakterija razvijenih na kvržicama korijena voćke, obogaćuju tlo dušikom potrebnim za rast i rodost voćaka. Trave svojim gustim korijenjem dobro popune tlo, čine zeleni tepih, a razvijaju i dosta zelene mase. Trava usitnjena malčermom uz intenzivnu mikrobiološku aktivnost, postupno trune i razgrađuje se, a hranjiva se oslobađaju. Kao jedan od najvažnijih nedostataka zatravnjivanja voćnjaka je slaba zračna propusnost. Taj nedostatak se može izbjeći primjenom razvijenog oruđa za površinsko prorahljivanje, koji tlo neće obrađivati, već svojom težinom i posebno izrađenim radnim organima-zupcima, razbiti površinski sloj debljine 8-10 cm. Primjenom malčera i površinskog prorahljivača (bez obrade) će se popraviti struktura tla, a time i bolje nakupljanje i čuvanje vlage u tlu (nakon oborina). Disanje tla je bolje, brži je i bolji razvitak mikroorganizama, koji obavljaju važnu ulogu u pretvorbi hranjiva iz teže u lakše pristupačne oblike. Kao rezultat toga je povećana produktivnost rada tijekom održavanja

tla, očuvanje povoljnih i popravljane nepovoljnih svojstva tla, te osiguranje poželjne rodnosti i visoke kvalitete plodova.

Najveću potrebu za vodom tijekom vegetacije imaju jabuke i šljive dok kruške, višnje, orah, breskve i marelice zahtijevaju manje vode tijekom vegetacije. Povoljni uvjeti za uspješan uzgoj većine voćnih vrsta su oni koji omogućuju da voda u tlu zauzima 65 do 85% poljskog vodnog kapaciteta (količina vode koju tlo u prirodnim uvjetima nakon oborina može maksimalno zadržati) u razdoblju od početka vegetacije do sazrijevanja plodova. Voćne sorte kraće vegetacije zahtijevaju manje vode tijekom vegetacije u odnosu na kasne sorte. Da bi voćka raspolagala potrebnom količinom vode, potrebno je voćnjak navodnjavati i to lakša tla zalijevati češće, ali manjim obrocima navodnjavanja u odnosu na voćnjake na srednje teškim i teškim tlima.

Prosječne potrebe oborina tijekom vegetacije, npr. kod jabuke i šljive, ovise od prosječnih dnevnih temperatura u vegetacijskom razdoblju svibanj-rujan u području u kojem se uzgaja. Pri prosječnoj dnevnoj temperaturi zraka (svibanj-rujan) od 16°C potrebno je oko 700 mm oborina, za svaki stupanj povećanja prosječne dnevne temperature za to razdoblje potreba za vodom se povećava za 80 mm. To je u određenom temperaturnom rasponu linearna ovisnost.

Preobilne oborine ili navodnjavanje može imati katastrofalne posljedice kako za život voćke tako i za strukturu tla.

Voćkama treba konstantno osigurati određene količine vode, putem oborina ili navodnjavanja, posebno tijekom tzv. kritičnih fenofaza, npr. kod šljive, zametanje plodova (12-14 dana nakon cvatnje), formiranja koštice (20-30 dana nakon cvatnje), početka formiranja cvjetnih pupova i 15 do 20 dana prije nastupanja fiziološke zrelosti plodova.

U području kontinentalne Hrvatske u 2000. i 2001. godini vrlo je izražen nedostatak oborine u ljetnom razdoblju, što se može vidjeti u priloženim tablicama.

Na prikazanim grafikonima može se vidjeti da je u 2000. godini u svibnju, lipnju, srpnju i kolovozu bilo razdoblje praktički bez oborina, što se vrlo negativno odrazilo na prinos i kvalitetu plodova. U 2001. godini osim nedovoljnih količina oborina izražena je i vrlo nejednolična raspodjela oborina tijekom vegetacije. U ovakvim (nepovoljnim) uvjetima primjena sustava za navodnjavanje je neophodna ukoliko se želi postići poželjna rodnost i visoka kvaliteta plodova.

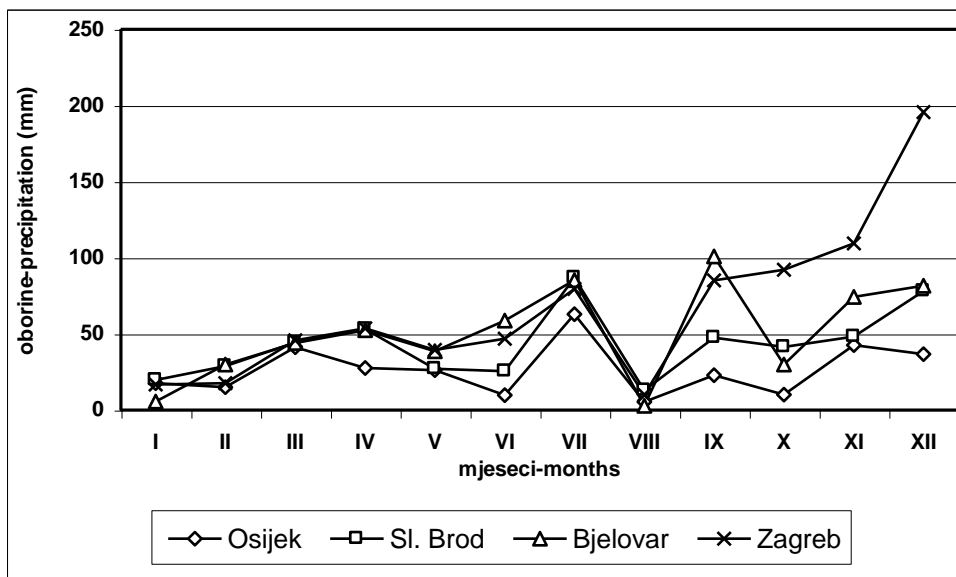

Grafikon 1. Raspodjela oborina u 2000. godini.

Figure 1. Precipitation distribution in 2000.

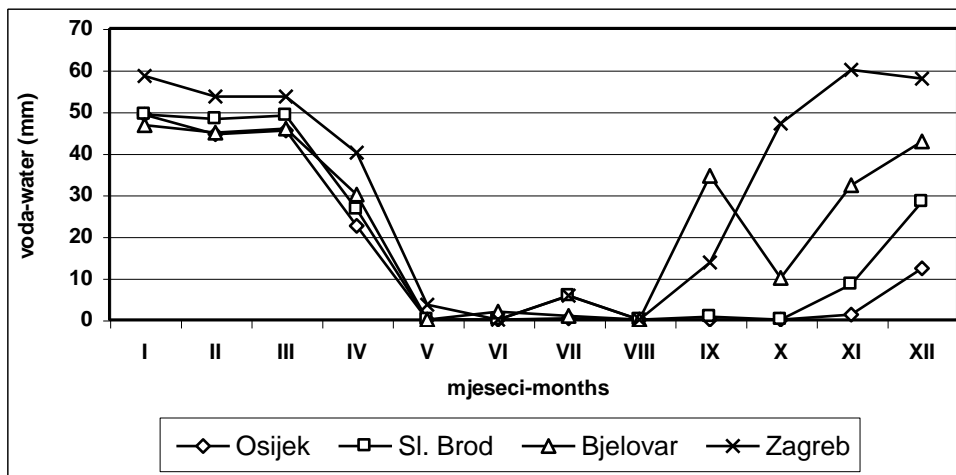

Grafikon 2. Sadržaj vode u sloju tla od 20 cm u 2000.godini.

Figure 2. Soil water content in the 20 cm soil layer in 2000.

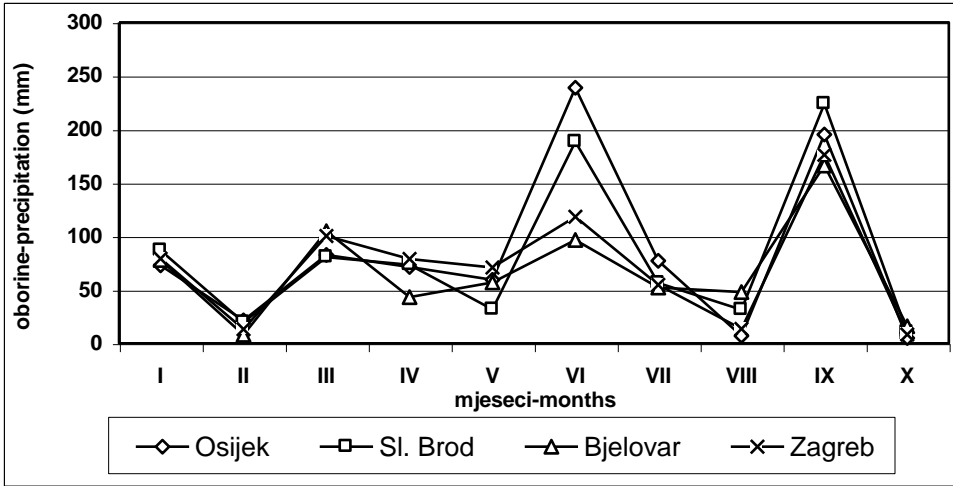

Grafikon 3. Raspodjela oborina u 2001. godini.

Figure 3. Precipitation distribution in 2001.

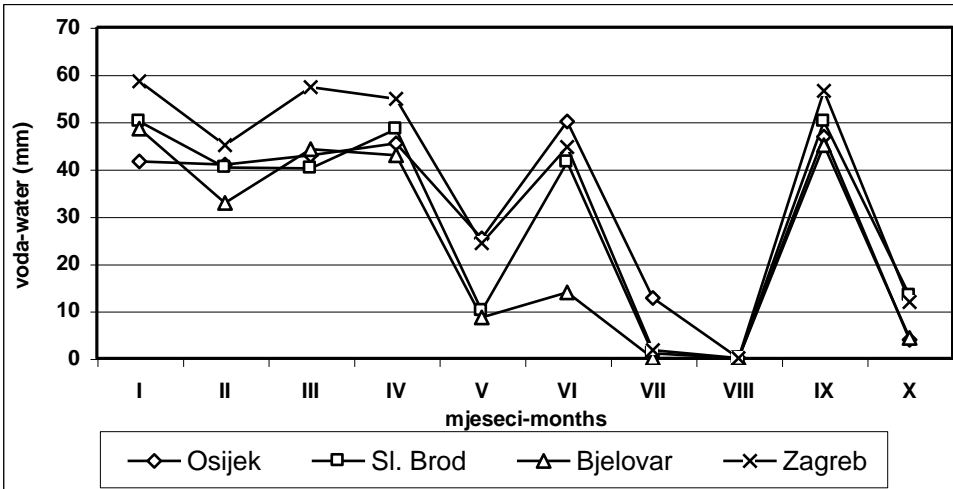

Grafikon 4. Sadržaj vode u tlu debljine 20 cm u 2001. godini

Figure 4. Soil water content in the 20 cm soil layer in 2001.

ZAKLJUČAK

Primjenom reduciranog načina održavanja tla, a s obzirom na agroekološke uvjete, se poboljšavaju biološka, kemijska i fizikalna svojstva tla, čime se postižu optimalni uvjeti za razvoj korijenovog sustava, te se povećava rodnost i kvaliteta plodova.

Odgovarajućim kombiniranjem malčiranja i površinskog prorahljivanja značajno se smanjuje gubitak vode iz tla u ljetnom razdoblju kada je inače vode u tlu najmanje a potreba voćke za vodom najveća.

Smanjenjem broja prohoda strojevima između redova nasada se značajnije umanjuje zbijenost tla. Zatravnjivanjem travno-leguminoznim kulturama nakon malčiranja se umanjuje negativno djelovanje pneumatika stroja na tlo i omogućuje se prohod strojevima nakon obilnih oborina (npr. zaštita). Uvođenjem reduciranog načina održavanja plodnosti tla umjesto permanentne (čiste) obrade, se smanjuju troškovi proizvodnje odnosno umanjuje se upotreba zaštitnih sredstava i mineralnog gnojiva, te se na taj način povećava ekonomičnost voćnjaka.

LITERATURA

1. BAUER K., (1996): Weinbau. Österreichischer Agrarverlag, Klosterneuburg.
2. Državni hidrometeorološki zavod: Podaci-komponente vodne bilance za 2000. i 2001. godinu.
3. ESTLER M. AND H. KNITTEL, (1996): Praktische Bodenbearbeitung. Österreichischer Agrarverlag, Klosterneuburg.
4. SINCLAIR T. R. AND F. P. GARDNER, (2001): Principles of Ecology in Plant Production. University of Florida, Institute of Food and Agricultural Sciences, Agronomy Department, Gainesville, Florida, USA.
5. STRAUSS E. AND R. NOVAK, (1998): Obstbau Praxis. Österreichischer Agrarverlag.

PROBLEMS OF MAINTENANCE OF SOIL FERTILITY IN ORCHARD

SUMMARY

Consequences of inadequate soil maintenance are impaired soil structure, intensive loss of organic matter-humus, high erosion, loss of nutrients, surface layer compaction, reduced life activity in soil (microorganisms), increased water loss, reduced exchange of gases in the root zone, poor growth, irregular fruition, underdeveloped roots, higher susceptibility to diseases (notably fungous), increased sensitivity to late spring frosts, etc. Such conditions have a direct influence on the increase of protection and fertilisation costs, poor exploitation of machinery, decrease of yield and fruit quality, i.e., considerably reduced cost-effectiveness of orchard production.

Key words: orchard, maintenance of soil, fertility, precipitation



PRIMJENA BLOB ANALIZE SLIKE ZA PRAĆENJE RASTA I RAZVOJA PLODOVA JABUKA SORTE 'GALA'

DENIS STAJNKO, MIRAN LAKOTA

Univerza v Mariboru, Fakulteta za kmetijstvo
Maribor, Slovenija

SAŽETAK

U voćnjaku zasađenom 4 godina starim jabukama sorte "gala" na podlozi M9, tijekom juna i augusta 2001, snimljeni su plodovi u različitim razvojnim fazama zbog proučavanja mogućnosti primjene slike za potrebe ocjenjivanja trenutačnog promjera odnosno uroda. Od dobijenih RGB slika najprije se odbrojila crvena slika, a zatim izvršila "blob analize" slika čiji rezultat su bili broj jabuka te njihov promjer po stablu. Ustanovljena je velika korelacija između ručnog i kompjutorskog brojanja jabuka, pa tako R^2 varira od 0,83 na kraju juna do 0,89 na kraju augusta. Promjer plodova dobijen ručnim mjerenjem te "blob analizom" iskazuje nižu korelaciju R^2 (0,65-0,69) što se prvenstveno pripisuje malom uzorku kod ručnog mjerenja. Slični korelacioni koeficijenti dobijeni su i kod ocjene trenutačnog uroda jabuka što je također posljedica dobijenih promjera. Ukazuje se velika mogućnost primjene "blob analize" slike za izgradnju modela za prethodno prognoziranje uroda jabuka u vrijeme ubiranja plodova, ako bi se u njega uključili elementi rodnog potencijala sorte, sistema sadnje te voćarskog rajona.

Ključne riječi: RGB slika, blob analiza, jabuka, promjer, urod

UVOD

U suvremenim voćarskim traktorima i strojevima sve se više uvažava kompjuterska tehnologija koja uz pomoć mikroprocesora omogućuje brzu obradu podataka potrebnih za neometan rad suvremenih motora, pumpi, hidraulike te mnogih drugih. Poseban dio kompjuterske tehnologije predstavlja razvoj umjetnog vida te postupci analize slike koji su ugrađeni u suvremene poljoprivredne i voćarske robote a također i sortirne i pakirne linije

za voće, te predstavljaju značajan dio sustava umjetne inteligencije koja odlučuje o načinu rada određenog robota ili stroja.

Peterson i suradnici (1999) ustanovili su određene manjkavosti odnosno smetnje prilikom procesiranja slika kod robota berača jabuka prouzrokovane promjenljivošću vanjske svjetlosti pa su koristili posebna platna te izvore umjetne svjetlosti kako bi omogućili konstantne uvjete rada. Do sličnih rezultata došao je i Kondo sa suradnicima (1998) kod robota berača jagoda.

Naime, puno lakše je odrediti uvjete svjetlosti prilikom detekcije boja, oblika te skladišnih bolesti plodova kod sortirnih linija. No još uvijek se istražuju novi kvalitetniji načini sortiranja pa su tako Yang i suradnici (1996) istraživali mogućnost upotrebe različitih algoritama za detekciju defekata i bolesti plodova jabuka, Currie sa suradnicima (2000) kontrolu pravilnih oblika jabuka, Paulus i suradnici (2000) razvrstavanje plodova prema traženim bojama, a Stenmetz sa saradnicima (1999) mjerio je količine šećera u plodovima jabuka pomoću metoda analize slike.

No vrlo malo se radilo na praćenju rasta jabuka te prognozi trenutačnog uroda pomoću metoda analize slike u uvjetima voćnjaka, čime se bavi ova rasprava. Razlozi za takvo stanje proizlaze iz velike varijabilnosti boja, oblika i svjetlosti prouzrokovane prirodnim uvjetima u voćnjaku te habitusa drveća koji dijelomice onemogućava ekzaktna snimanja.

METODE RADA

Plan snimanja u voćnjaku

Sve snimke napravljene su digitalnim fotoaparatom OLYMPUS C3030 na fakultetskom dobru UKC Pohorski dvor u voćnjaku zasađenim jabukom sorte "Gala" na podlozi M9, zasađenom 1998 godine uzgajanom u obliku vrlo vitkog vretena. Rezolucijom 1600x1200 pixela snimilo se dvadeset slučajnim izborom odabranih stabala u tri vremenska razdoblja:

1. put - nakon lipanjskog opadanja plodića 28.06.2001
2. put - mjesec dana kasnije 21.07.2001
3. put – za vrijeme berbe 20.08.2001
4. ubiranje plodova – vaganje i mjerenje promjera 28.08.2001

Fotografiranje se je izvršilo sa udaljenosti 3 m uz upotrebu umjetne svjetlosti (flash), jer smo u našim dosadašnjim istraživanjima Stajanko et al. (2001a, 2001b, 2001c) ustanovili da jedino kontrolirana svjetlost obezbjeđuje konstantne uslove za objektivnu ocjenu analize slika. Slikanje drveća sa svjetlije strane, odnosno okrenute ka suncu, izvršilo se je automatskim programom, dok se je za snimanje protiv sunca, odnosno dijelova drveća okrenutih od sunca, koristio manualni program kojim se je vršila korekcija dužine osvjjetljenja pomoću otvorenosti blende (zaslona), te vremena osvjjetljenja.

Ručno brojanje

Na svakom odabranom stablu prilikom svakog termina fotografiranja ručno smo prebrojali sve plodiće te izmjerili promjer deset slučajno odabranih plodova pomoću ručnog mjerila odnosno šublera. Taj postupak smo ponavljali i prilikom ubiranja plodova, kada smo urod i izvagali elektronskom vagom.

Obrada slika

Na fotografijama dobijenim u voćnjaku miješao se cijeli niz boja, oblika i inteziteta svjetlosti koje je sačinjavalo lišće, plodovi, grane i okoliš pa smo zbog toga morali najprije pripremiti za daljnju obradu upotrebom RGB palete koja je izvršila razradu originalne fotografije u njezine tri osnovne boje odnosno slike crvenu (R), zelenu (G) te plavu (B). Nakon toga od originalne fotografije odbrojila se crvena slika, kako bi se dobila tzv. SUBTRACT slika (slika 1).



Slika 1. Odbrajanjem crvene slike od RGB slike dobija se "subtract"

Tako dobijena slika pretvorila se u sivu sliku na kojoj se je izradio histogram i analiziralo područje traženih objekata, a nakon definiranja ciljnog područja, slika se pomoću 'thresholding-a' razdvojila na bitni i nebitni dio, pa se tako dobila binarna slika (slika 2).



Slika 2. Binarna slika nakon izvedenog thresholdinga

Pročišćavanje binarnih slika izvodilo se algoritmom connectivity-4 kojim se je razgraničilo objekte prema raspodjeli pixela po dijagonali.

Na pročišćenoj binarnoj slici kreiran je cilj odnosno 'template' pomoću kojeg se je izvršila blob analiza slike koja nam je iznesla broj objekata te njihov ekvatorijalni promjer (slika 3).



Slika 3: Jabuke te njihovi ekvatorijalni promjeri dobijeni nakon pročišćavanja binarne slike te traženja označenih uzoraka

Svi izračunati rezultati pretvorili su se iz pixela u realne mjerne jedinice pomoću kvocijenta pixel/mjerilo koji se je empirički definirao uz pomoć mjerenih krugova koje su se namjestili na slikana stabla jabuka.

Obrada slika pa i daljnje analize izvele su se pomoću vlastito izrađenih programa GALASEARCH, GALAPROGNOSE koji su razvijeni pomoću programa IMAQ Vision, Version 4.1.1 firme National Instruments, USA, koji predstavlja dio šireg programa LABVIEW Version 6.0 istog proizvođača.

Praćenje razvoja plodova i izračun uroda

Razvoj plodova odnosno prirast plodova ustanovili smo mjerenjem promjera plodova na slikama snimljenih u različitim razvojnim fazama odnosno dobima također uz pomoć blob analize. Naime, kao što se vidi iz jednadžbe 1, prirast promjera plodova jabuka tijekom vegetacije prema Mitchell-u citirano po Welte-u (1990), u vrlo je dobroj korelaciji sa prirastom težine plodova, pa se kao takav može upotrijebiti za izračun trenutačne težine plodova.

$$m_p = a \cdot r^b \quad (1)$$

gdje je m_p prosječna masa jednog ploda (g), a r promjer plodova (mm)

S druge strane, teoretički urod jabuka po stablu može se izračunati poznavanjem broja jabuka dobijenim pomoću analize slike, te izračunate prosječne mase jednog ploda kao što se vidi iz jednačbe 2.

$$m_d = n \cdot m_p \quad (2)$$

ako je m_d masa uroda na jednom stablu (g), n broj plodova izmeren analizom slike, a m_p prosječna masa jednog ploda (g).

REZULTATI RADA

Broj plodova na drveću

Broj plodova po drveću tijekom tri analizirana perioda neznajno opada što se može pripisati fiziološkim utjecajima vrlo vrućeg i sušnog ljeta, pa je dio plodova otpao iako su bili voćnjaci navodnjavani. Isti trend ustanovljen je i blob analizom slike, ali je broj jabuka u sva tri termina statistički neznajno manji. Kao što se vidi s tabele 1, korelacioni koeficijenti između ručnog brojanja plodova te blob analize povećavaju se dužinom vegetacije i mogu se pripisati bojanjem plodova na crveno tijekom zriobe, što omogućava precizniju i efikasniju analizu.

Tabela 1. Izračunati korelacioni koeficijenti između ručnog brojanja (r.b.) plodova te blob analize (b.a.) u različitim razdobljima

Datum	Broj jabuka po stablu - prosjek r.b.	Broj jabuka po stablu – prosjek b.a.	R ²
28.06.2001	28,3	25,8	0,83
21.07.2001	27,6	25,7	0,87
20.08.2001	26,8	25,2	0,88
28.08.2001-berba	25,5	-	-

Promjer plodova jabuka

Plodovi jabuka tijekom vegetacije konstantno su se debljali sve do svoje tehnološke zrelosti kada su bili obrani (tabela 2). Taj trend ustanovljen je kod oba načina mjerenja, ali za razliku od statističkog vrednovanja broja jabuka, korelacioni koeficijenti R² su manji nego kod broja plodova. Dodatnim provjeravanjima t-testom dokazali smo da su uzorci po deset jabuka bili premali za postizanje bolje korelacije, ali stvarno predstavljaju dio cijele populacije jabuka koje smo izmjerili blob analizom.

Tabela 2. Vrijednosti t-testa za ručno mjerenje (r.m.) te blob analizu (b.a.) promjera jabuka u različitim razdobljima vegetacije

Datum	Prosjeck promjera po stablu (mm) r.m.	Prosjeck promjera po stablu (mm) b.a.	R ²	t-test
28.06.2001	40,11	40,12	0,63	0,01
21.07.2001	55,45	55,46	0,64	0,01
20.08.2001	70,90	70,85	0,69	0,01
28.08.2001-berba	77,17	-	-	-

Urod plodova jabuka

Polazeći od jednadžbi 1 i 2 koje baziraju na broju i promjeru jabuka, ustanovili smo porast uroda u zavisnosti od duljine vegetacije. Kao što se vidi s tabele 3, ocijenjeni urod jabuka pomoću blob analize statistički neznačajno je manji kod svih analiziranih termina, što proizlazi iz prosječnog broja jabuka po stablu, kao što je već zapisano u tabeli 1. Korelacioni koeficijenti R² zauzimaju vrijednosti slične onima kod primjera, ali t-testom također smo dokazali da su uzorci po deset jabuka te njihov urod stvarno dio cijele populacije jabuka koje smo izmjerili blob analizom.

Tabela 3. Ocijenjeni trenutačni urod plodova jabuka izračunat na temelju ručnog mjerenja te blob analizom u različitim razdobljima vegetacije

Datum	Prosječan urod po stablu r.m. (kg)	Prosječan urod po stablu b.a. (kg)	R ²	t-test
28.06.2001	2,09	1,91	0,63	0,05
21.07.2001	2,81	2,62	0,65	0,05
20.08.2001	3,49	3,28	0,69	0,05
28.08.2001-berba	3,81	-	-	-

ZAKLJUČAK

Na fakultetskom dobru "Pohorski dvor" u razdoblju nakon opadanja plodova od juna do augusta 2001. godine digitalnim fotoaparatom snimljeno je dvadesetak stabala jabuka sorte "gala" kako bi se ustanovila mogućnost upotrebe blob analize slike za ocjenjivanje trenutačnog uroda te komparaciju prirasta od prethodnog termina. Ustanovili smo veliku preciznost uporabe blob analize za ocjenjivanje broja plodova pa tako korelacioni koeficijent R² koji opisuje korelaciju u usporedbi sa ručnim brojanjem iznosi od 0,83 krajem juna do 0,89 krajem augusta. Nešto slabiji korelacioni koeficijenti R² (od 0,65-0,69) postignuti su kod mjerenja promjera jabuka te izračuna trenutačne mase uroda koja i bazira na promjeru. Detaljnijom analizom rezultata pomoću t-testa ustanovljeno je da je prosjek deset uzetih uzoraka kod ručnog mjerenja stvarno dio svih plodova na stablu. Naime kod analize slike za kalkulacije se uzimao prosjek svih prebrojanih plodova, a kod ručnog samo deset što je i vodilo do različitih rezultata te manje korelacije.

Postignuti rezultati veliki su podsticaj za daljnji razvoj modela kako bi došli do programa koji bi nam omogućio prognoziranje uroda za vrijeme berbe na temelju junskih odnosno julskih snimki. Da bi se to postiglo potrebno je uključiti više faktora koji opisuju kapacitet sorte, urod, mogućnost podloge, sistem sadnje, starost voćnjaka, dužina vegetacije te mnogi drugi.

LITERATURA

1. IMAQ Vision for G Reference Manual, National Instruments Corporate Headquarters, 1997, 345.
2. CURRIE, AJ., GANESHANANDAM, S., NOITON, DA, GARRICK, D., SHELBORNE, CJA., ORAGUZIE, N., (2000) Quantitative evaluation of apple (*Malus x domestica* Borkh.) fruit shape by principal component analysis of Fourier descriptors, *Euphytica*, 111(3) 219-229
3. GRAND D'ESNON, A., RABATEL, G., PELLENE, R., JOURNEAU, A., (1987) Magali-A self propelled robot to pick apples. ASAE Paper No.87-1037. St. Joseph, Mich.:ASAE
4. HARRELL, R., (1987) Economic analysis of a robot citrus harvester in Florida. *Transactions of the ASAE* 30(2): 298-304

5. KONDO, N. et al. (1998) Development of Strawberry Harvesting Robotic Hand, ASAE Paper No.983117, , 7 s. MI.:ASAE
6. KOLLENBURG-CRISSAN, L.M., et al. (1998) Machatronic system for automatic harvesting of Cucumberis, IFAC Control Application and Ergonomics in Agriculture, June, Athens, p-289-293
7. PAULUS, I., COPPENOLLE, H., SCHREVEENS, E., (2000) Modelling the consensus and differences between assessors inspecting the colour quantity of apples by 'tree-base modelling', *Journal of the Science of Food & Agriculture*, 80(13): 1953-1963
8. PETERSON, D.L.et al. (1999) A System Approach to Robotic Bulk Harvesting of Apples, ASAE Paper, 6 s. MI.:ASAE
9. STAJNKO, D., LAKOTA, M., (2001a) Using image processing and analysis techniques for counting apple fruits in the orchard, *Horticultural Science (Prague)* 28, 2001(3), p. 95-99
10. STAJNKO, D., LAKOTA, M., (2001b) Primjena metoda procesiranja i analiziranja slika za brojanje plodova jabuka. *Proceedings of the 29. Int'l symposium "Actual Tasks on Agricultural Engineering; Opatija, Croatia, 281-287.*
11. STAJNKO, D., LAKOTA, M., (2001c) Štetje plodičev jabolk s pomočjo 'blob analize' slike. *Zbornik simpozija Trendi v razvoju kmetijske tehnike, Radenci, 14. in 15. junij 2001.* Ljubljana: Društvo kmetijske tehnike Slovenije, [2001], str. 227-232.
12. STEINMETZ, V., ROGER, JM., MOLTO, E., BLASCO, J., (1999) On-line fusion of colour camera and spectrophotometer for sugar content prediction of apples, *Journal of Agricultural Engeneering Research*, 73(2) p. 207-216
13. Wen, Z. et al. (1998) Rule-based Decision-making for Apple Defect Detection and Removal, ASAE Paper No. 986107, 13 s. MI.:ASAE
14. WELTE, H.F., (1990) Forecasting harvesting fruit size during the growth season, *Acta Horticulturae*, 276, p.275-282
15. YANQ QS., MARCHAND JA., (1996) Accurate blemish detection with active contour models, *Computers & Electronics in Agriculture*, 14(1) p.77-89

THE IMPLEMENTATION OF BLOB ANALYSIS FOR PREDICTING THE DEVELOPMENT AND YIELD OF APPLE VARIETY "GALA"

SUMMARY

During the vegetation period June-August 2001, digital pictures from twenty 4-years old apple trees, variety 'gala', was captured every month by applying CCD camera. Every RGB picture was transformed by subtracting the red image before being proceeded by blob analysis technique which resulted the number and diameter of apple fruits. A very strong correlation was calculated between manually counted number of apple fruits and the blob analysis. R^2 increased from 0,83 at the end of June to 0,89 at the end of August due to the colour development during the ripening. The correlation between manually measured and computed diameter of apple fruits indicated lower correlation R^2 i.e. 0,65-0,69 due to number of fruit samples taken per tree by measuring procedure, instead of all samples being observed in the blob analysis. The same results and reasons for them appeared by calculating the correlation for the yield in each observed period. By using blob analysis, a model for forecasting the yield at the harvesting time could be developed by implementing more data concerning potential yield capacity of apple variety.

Key words: RGB image, blob analysis, apple, diameter, yield



COOL-SIMU: A CFD SOFTWARE FOR SIMULATING AIRFLOW AND HEAT TRANSFER PROCESSES IN VENTILATED PACKAGING SYSTEMS

QIAN ZOU*, LINUS U. OPARA*, ROBERT MCKIBBIN[†]

*Institute of Technology and Engineering
Massey University
Wellington, New Zealand

[†]Institute of Information and Mathematical Sciences
College of Sciences
Massey University
Albany, New Zealand

SUMMARY

This paper outlines the development and structure of a CFD-based software for simulating airflow patterns and heat transfer in packaging systems during cooling of fresh produce. The software is made up of five components, namely the airflow solver, heat solver, system designer (enables the user to specify the product properties, packaging system, and airflow conditions), solution monitor (allows the user to monitor and control the solution processes of the airflow and heat transfer models), and the visualisation tool (which enables the user to visualize the predicted airflow patterns and temperature profiles).

Each software component has been developed to provide a user-friendly interaction for data input and analysis, and also integrated into the overall modelling system, thereby facilitating wider applicability of the software for research, teaching and extension service. Results from a case study of precooling apples inside ventilated corrugated paperboard packaging is used to demonstrate the application of the software for packaging design and performance testing.

Key words: CFD, mathematical modeling, airflow, heat transfer, simulation, visualization, packaging design, precooling, fresh foods, storage

INTRODUCTION

Airflow patterns impact on many thermodynamic and transport processes in agriculture and horticulture. In protected cultivation structures such as greenhouses (Lamrani et al., 2001), livestock housing (Phillips et al., 2001) and mushroom houses (Lomax et al., 1995), airflow and heat transfer are important factors affecting plant and animal performance and emission rates of environmental pollutants.

In postharvest operations including cooling of fresh produce and drying of grains, appropriate airflow and distribution inside the handling and processing equipment such as dryers, packaging, and storage structures is important for heat and mass transport to permit the desired effects of maintaining the cool-chain or removing moisture from the product. During drying, air velocity is only next to air temperature in influencing drying performance (Sarsavadia et al., 1999; Syarief et al., 1984). During fresh produce cooling and storage, inadequate airflow rates can lead to difficulties in maintaining a cool-chain. On the other hand, excessive airflow results in high water loss, which manifests in quality loss such as shriveling, softening and reduction of crispness (Willis et al., 1989; Hackett et al., 1987.).

Ventilated packaging is widely used for handling fresh fruit and vegetables. The extent of ventilation on the package affects produce cooling rate and maintenance of a cool-chain. For instance, Ladaniya and Singh (2000) showed that increasing ventilation on the sides of cartons of fresh mandarins from 2% to 6% reduced the required cooling time of produce from 12.5 to 8 hours. Airflow patterns and heat transfer processes inside such ventilated packaging containing fresh produce are rather complex, and experiment-based methods for packaging design are laborious, time-consuming and expensive. For such complex structures and fluid dynamic process, computational fluid dynamics (CFD) modeling offers an innovative numerical tool to assist in their design and performance evaluation. Existing commercial CFD codes often require considerable adaptation to be suitable for such specific applications, thereby incurring substantial investment in local institutional research and development time and resources.

A research programme was instigated to develop prediction tools for the design and performance assessment of ventilated packaging systems used in the fresh produce industry. In addition to reducing the cost and development cycle for new packaging by minimizing extensive experimental testing, an immediate benefit of such innovative tools is in predicting product cooling rates, quality changes and packaging thermal stability during postharvest handling and storage. The objective of this paper is to describe the structure of a new CFD-based software for simulating airflow patterns and heat transfer in ventilated produce containers. Results from the analysis of fresh apples undergoing precooling inside ventilated corrugated paperboard packaging is used to demonstrate the application of the software. Key features of the software are user-friendliness and quasi-real-time visualization of the simulation process and results.

COMPUTATIONAL FLUID DYNAMICS MODELLING

CFD modelling is the process of representing a fluid flow problem by mathematical equations based on the fundamental laws of physics, and then solving those equations using computer to predict the variation of the relevant parameters within the flow field (Jones and Whittle, 1992). The use of CFD in research and solution of industrial problems involves three main steps: the definition of problem, its solution, and analysis of the results (Scott and Richardson, 1997). The definition of a CFD problem includes setting the boundary and/or initial conditions of a fluid field, and then analyzing the flow characteristics. Based on the analysis, proper differential and auxiliary algebraic equations are chosen to formulate the transport phenomena of interest.

After formulating the governing equations for the transport processes, the process of CFD solution consists of four additional steps that are illustrated in Figure 1. The first step is discretisation in which the continuous partial differential equations and auxiliary (boundary and initial) conditions are converted into a discrete system of algebraic equations. The next step in the solution process applies an equation solver to provide the solution of the system of algebraic equations (Fletcher, 1988). While analysing a CFD prediction, the output data are usually presented in graphic forms that are easily interpreted. Experimental validation is considered essential for final application of simulation results.

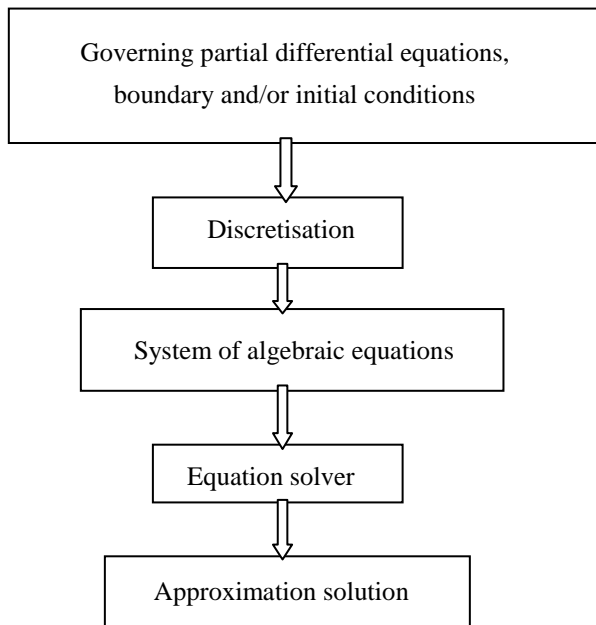

Figure 1. Overview of the computational solution procedure in CFD (Fletcher, 1988)

DEVELOPMENT OF MATHEMATICAL MODELS

General transport equations

Models were developed to characterize the airflow and heat transfer in ventilated packaging based on the fundamental conservation laws of fluid dynamics that describe the transport phenomena. The general equations directly related to fluid velocity and pressure, are: (1) the Navier-Stokes equations, which are derived from conservation of fluid momentum, and (2) the continuity equation, which represents the conservation of mass. By solving these equations the fluid velocity can be predicted. For temperature prediction, an equation for the conservation of energy has to be solved. If an additional variable, for instance, water vapour concentration in air, is to be calculated, the solution of an additional equation must be obtained for this variable (Peyret and Taylor, 1983).

The conservation equations, also known as field equations, represent the variation of solution variables in space and time. These basic equations for incompressible, viscous flow are presented as follows in Cartesian form:

1. Continuity equations (mass conservation equation)

$$\frac{\partial u_i}{\partial x_i} = 0 \quad (1)$$

where u_i is the component of velocity in x_i direction ($\text{m}\cdot\text{s}^{-1}$).

2. Navier-Stokes equations (momentum conservation equations) for fluid with constant viscosity

$$\rho_f \frac{\partial u_i}{\partial t} + \rho_f u_j \frac{\partial u_i}{\partial x_j} = \rho_f g_i - \frac{\partial p}{\partial x_i} + \mu \frac{\partial^2 u_i}{\partial x_j^2} \quad (2)$$

where:

t = time (s).

ρ_f = fluid density (kg m^{-3}).

g = gravitational constant (m s^{-2}).

g_i = components of gravitational constant (m s^{-2}).

p = fluid pressure (N m^{-2}).

μ = fluid dynamic viscosity (N s m^{-2}).

3. Equation for energy conservation

$$\rho_f C_p \frac{\partial T_f}{\partial t} + \rho_f C_p u_j \frac{\partial T_f}{\partial x_j} = \frac{\partial}{\partial x_j} \left(K_f \frac{\partial T_f}{\partial x_j} \right) \quad (3)$$

where:

T_f = fluid temperature (T).

C_p = fluid constant-pressure specific heat capacity ($J K^{-1} kg^{-1}$).

k_f = fluid thermal conductivity ($W K^{-1} m^{-1}$).

Auxiliary equations are generally necessary to describe the boundary and initial conditions of the fluid flow problem. For unsteady flows as commonly occurs inside complex structures like fresh food packaging, the initial conditions include initial values of velocity components, temperature, turbulence quantities for turbulent flows and any other quantities that are solved-for. The boundary conditions that are commonly encountered are the inflows, outflows, and wall functions (Zou, 2002).

Analysis and modeling of airflow and heat transfer inside ventilated packaging for fresh produce

Ventilated packages used for fresh produce are either layered packages (Fig. 2) in which products are placed in several trays, and then the trays are stacked into a package, or bulk packages in which products are directly put in a large package. Wooden or plastic bulk bins used to collect fruit and vegetables during harvesting and /or storage are the most common types of ventilated bulk packaging.



Figure 2. A ventilated layered apple carton

Based on the principles of the fundamental transport equations described earlier in Equations 1-3, numerical models of airflow and heat transfer in both bulk packaging and layered cartons were formulated. The airflow patterns were modeled by mathematically characterizing the conservation of air mass and momentum inside the package. Auxiliary equations (for porosity, permeability and empirical constants) and boundary conditions were also formulated. Heat transfer in both bulk packaging and layered packaging was described mathematically by the conservation of energy in (I) plain air region, (II) solid regions (package walls, trays, and produce), and (III) produce-air regions. Relevant auxiliary equations and boundary conditions were also formulated. Details of the general

modeling concept, overall model development and solution procedure for the ventilated packaging model are described elsewhere by Zou (2002).

SOFTWARE DEVELOPMENT

A user-friendly software package called ‘CoolSimu’ was developed to integrate the solution procedures of the airflow and heat transfer models. The airflow and heat transfer solvers were first written as collections of MATLAB functions, and then translated into C libraries that are dynamically linked to the MATLAB functions. The overall structure of the software enables users who do not have prior knowledge of CFD and thermodynamics to simulate airflow and heat transfer processes in bulk and layered packaging systems by relying on the interactive software interfaces. Users of CoolSimu interact with the software via three components, namely:

- System designer: allows the user to define product geometric and physical properties, packaging system (geometry, shape and orientation, vent dimension, location and shape, and stacking arrangement of packages) and airflow conditions (directions, air properties);
- Solution monitor: used to specify the solution settings, start the airflow or heat solver, monitor the solution progress, and to abort the solution process);
- Visualization tool: used to display the predicted velocity, pressure and temperature results.

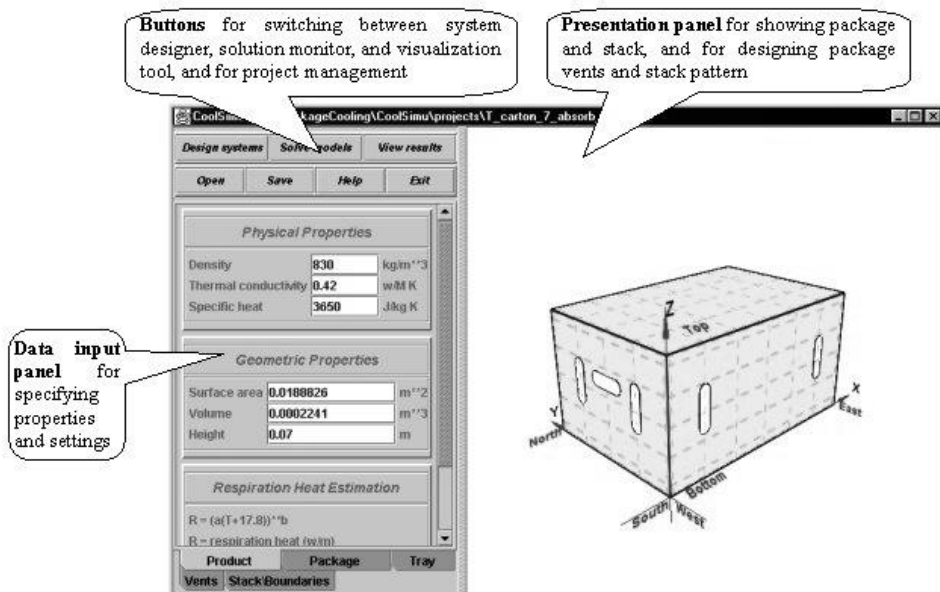

Figure 3. Simulation environment interface of the software ‘CoolSimu’

Figure 3 shows the layout of the overall simulation interface environment, while Figure 4 shows a typical interface for defining the vent characteristics.

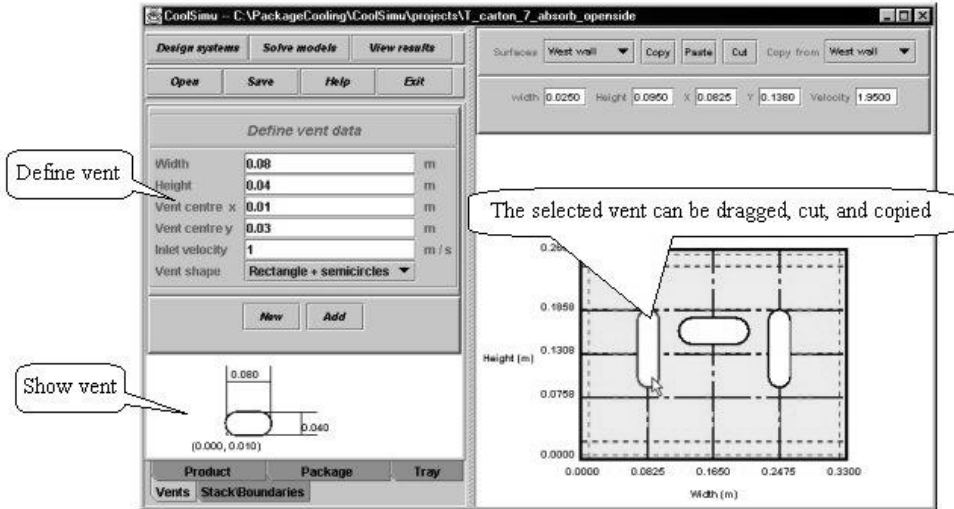

Figure 4. Simulation interface for defining vent characteristics

SOFTWARE APPLICATION TO VENTILATED PACKAGING FOR FRESH FRUIT

The software developed was used to simulate the airflow and heat transfer inside a standard apple carton (Figure 2) with four layers undergoing precooling. Experiments were carried out in a pre-cooler to measure fruit center temperature and air velocity inside the carton using data-logged temperature sensors and hot-wire anemometers. Simulation results included detailed airflow patterns, pressure and temperature profiles along each layer of fruits. In this paper, only a comparison of predicted and measured fruit cooling rates is presented to demonstrate model accuracy against experimental data.

Overall, good agreements were obtained between model predictions and measured data. Discrepancies noted at the beginning of cooling were attributable to the time needed for the temperature of the data-logger to equilibrate with the precooling conditions. Figure 5 shows the comparison of the predicted and measured fruit center-temperatures in the top layer of the ventilated apple carton. In general, the location the vents on the packaging affected airflow patterns and produce cooling rates between the fruit layers. Correspondingly, fruit near the inlet vents and those in the middle layer cooled much faster than those at the top and bottom layers. The effects of the intra- and inter-tray variations in airflow patterns and product cooling rates on fruit storage life and sensory quality attributes warrant further research.

CONCLUSIONS

Ventilated packaging and precooling are common postharvest handling practices in the fresh food industry to facilitate rapid removal of field heat and subsequent maintenance of the coolchain. Ventilated packaging design is currently more of an art than engineering design as exemplified by the multitude of vent shapes, sizes and orientations found on fresh produce packages in the market.

A new software ‘CoolSimu’ has been developed for simulating airflow patterns and heat transfer processes inside ventilated containers based on computational fluid dynamics. The overall structure of the numerical models and software enables the user to input design data for the packaging material and structure, product, and the fluid handling environment using relevant interfaces. This feature makes the software relevant in agricultural and biosystems engineering research, teaching and extension, and also ensures its wider application to a range of packaging systems and food products undergoing heating or cooling. Case study application of the software to ventilated packaging of fresh apples during precooling gave good agreement between model predictions and experimental results. The results also highlighted the existence of micro-climates inside the carton which contributes to variations in product cooling rates and potentially, variations in quality of otherwise good quality produce. Further refinement of the software is ongoing to include a mass transfer component for simulating moisture transfer and mass loss of stored produce.

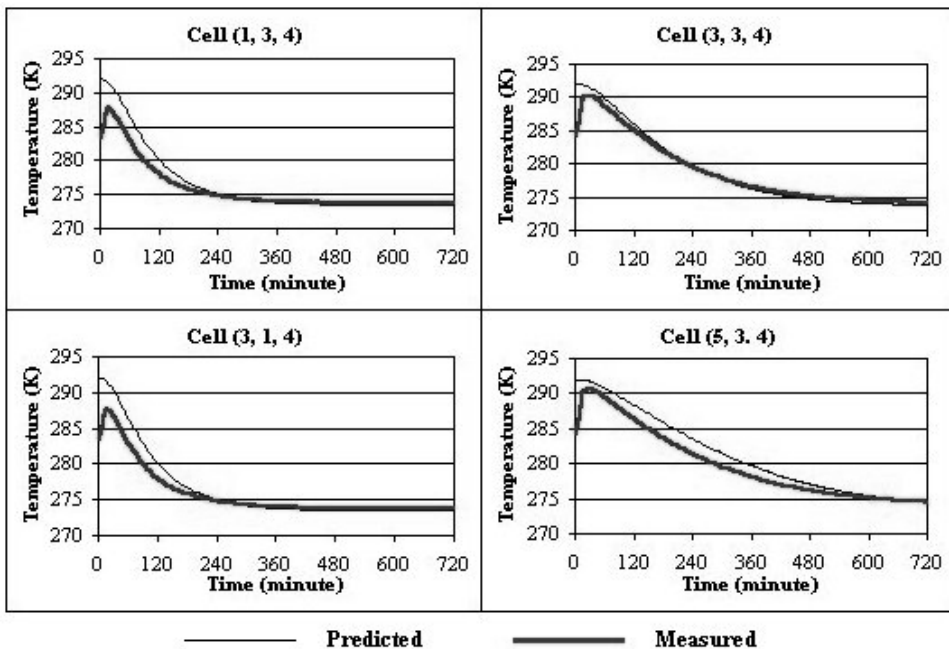

Figure 5. Predicted and measured fruit center-temperature in top layer of ventilated apple carton during forced-air precooling.

ACKNOWLEDGEMENTS

This research was financially supported by a research grant “Collis Blake Research Award” at Massey University received by Dr L.U. Opara. The authors are grateful to the donor and for this financial contribution and encouragement.

REFERENCES

1. FLETCHER, C.A. (1988.) *Computational Techniques for Fluid Dynamics. Volume I, Fundamental and General Techniques.* Springer-Verlag Berlin Heidelberg, New York.
2. HACKETT, J.M., MORESY, R.V. AND THOMPSON, D.R. (1987.) Precooling of fresh market Broccoli. *Transaction of the A.S.A.E.*, 30 (5): 1489-1493.
3. JONES, P.J. AND WHITTLE, G.E. (1992.) Computational fluid dynamics for building air flow prediction-current status and capabilities. *Building and Environment*, 27: 321-338.
4. LADANIYA, M.S. AND SINGH, S. (2000.) Influence of ventilation and stacking patterns of corrugated fibre board container on force-air pre-cooling of ‘Nagpur’ Mandarins. *Journal of Food Science and Technology*, 37(3): 233-237.
5. LAMRANI, M.A., T. BOULARD, J.C. ROY AND A. JAFFRIN. (2001.) Airflow and temperature patterns induced in a confined greenhouse. *Journal of Agricultural Engineering Research*, 28(1): 75-88.
6. LOMAX, S. GOTTFRIED AND H. LAVELLE. (1995.) Airflow indicators for mushroom houses. *Journal of Agricultural Engineering Research*, 60(1): 43-48.
7. PEYRET, R. & TAYLOR, T.D. (1983.) *Computational Methods for Fluid Flow.* Springer-Verlag New York Inc. New York.
8. PHILLIPS, V.R., D.S. LEE, R. SCHOLTENS, J.A. GARLAND AND R.W. SNEATH. (2001.) A review of methods for measuring emission rates of ammonia from livestock buildings and slurry or manure stores, part 2: monitoring flux rates, concentrations and airflow rates. *Journal of Agricultural Engineering Research*, 28(1): 1-14.
9. SARSAVADIA, P.N., SAWHNEY, R.L., PANGAVHANE, D.R. AND SINGH, S.P. (1999.) Drying behaviour of brined onion slices. *Journal of Food Engineering*, 40: 219-226.
10. SCOTT, G. AND RICHARDSON, P. (1997.) The application of computational fluid dynamics in the food industry. *Trends in Food Science & Technology*, 8: 119-124.
11. SYARIEF, A.M., MOREY, R.V. AND GUSTAFSON, R.J. (1984.) Thin-layer drying rate of sunflower seed. *Transaction of the A.S.A.E.*, 27(1): 195-200.
12. WILLS, R.B.H., MCGASSON, W.B., GRAHAM, D., LEE, T. H. AND HALL, E.G. (1989.) *Postharvest: An introduction to the physiology and handling of fruit and vegetables.* NSWU Press.
13. ZOU, Q. (2002.) A CFD modeling system for airflow and heat transfer in ventilated packing systems during forced-air cooling of fresh produce. Unpublished PhD thesis, Massey University, New Zealand.



PHYSICAL AND MECHANICAL PROPERTIES OF ALMOND AND ITS KERNEL RELATED TO CRACKING AND PEELING

KHAZAEI. J., A. M. BORGHEI, M. RASEKH, H. RABANI

University of Tehran
Faculty of Agriculture, Department of Agricultural Machinery
Karaj, Iran

SUMMARY

This study investigated the effects of loading rate, loading direction and almond size on the cracking characteristics of almond nuts. Almond cracking force, absorbed energy, and required power were in the range 139-1526 N, 70-2093 mJ, and 0.015-5.121W, respectively. Loading rate had a significant effect on cracking force and required power; however, its effect on absorbed energy was not statistically significant ($P=0.01$). Both almond size and loading direction had significant effects on cracking force, absorbed energy and required power.

Water immersion studies showed that the rate of water uptake was maximum during the initial phase of soaking, with the moisture content of kernel increasing from 6.46% to 20.24% (dry basis) following 1 hour of soaking. Empirical models were developed to characterise the moisture content of kernels over soaking time and between physical properties of almond and kernels.

Almond thickness had the highest kurtosis coefficient with average 1.71, but its mean skewness coefficient was near to zero. Conversely, kernel width had the highest coefficient of kurtosis (mean value 4.4), and the least value for skewness coefficient (mean 0.28). Empirical models were developed between dimensions of almond and kernels.

Key words: *physical and mechanical, almond, mechanical strength, water absorption, dimension, absorbed energy*

INTRODUCTION

The annual production of almond in Iran is equivalent to 80,000 tons. Some of the most important processing steps after almond harvesting are separation of kernel from the shell, wetting the kernels in water for about 13 hours, peeling the wet kernel, and drying the peelings. Determining the physical and mechanical properties of almond and its kernel are necessary for the design of an almond cracker, peeler machine and peeling dryer. Therefore, the objectives of this research were to: (a) determine the physical properties of almond and the kernel; (b) quantify the force, absorbed energy and required power for cracking the almond, and (c) characterise the hydration characteristics of almond kernels.

BACKGROUND

Oloso and Clark (1993) studied the effect of moisture content, pre-damage type, and direction of loading on cracking force, cracking deformation and absorbed energy up to the cracking point of roasted cashew nut under quasi-static loading. They found that all the factors examined significantly affected on the measured parameters and also on the pattern of cracking of the nut shell. Liang et. al (1984) carried out similar investigation on walnuts and found that the difference between kernel and walnut cracking deformation appeared to be a dependable indicator for predicting the effect of moisture content and compression magnitude on kernel damage.

The effect of direction of applied loading and nut dimension has been investigated by other researchers. For walnuts at 6% moisture content (wet basis), Borghei et. al. (2000) reported that mean cracking force and relative deformation¹ were 110-800 N and 0.01-0.045, respectively. The study also showed that large sized walnuts required higher cracking force and experienced more deformation than small ones.

Singh and Kulshrestha (1987) determined the water uptake of soybeans during soaking by recording the weight increase in bean with respect to time. The following simple models were suggested to express the variation of moisture content with time:

$$\frac{M_e - M}{M_e - M_0} = \frac{1}{kt - 1} \quad (1)$$

where: M_0 , M_e and k are initial moisture content, equilibrium moisture content and constant coefficient, respectively; and

$$\frac{M - M_0}{M_e - M_0} = \frac{Kt}{Kt + 1} \quad (2)$$

¹ -Relative deformation was equal to the walnut deformation divided by that almond dimension in direction which the load was applied.

MATERIALS AND METHODS

In this study the effects of the following factors on almond cracking force, absorbed energy, and required power were studied: loading direction (side and front), almond dimension (small, medium, large), and loading rate (5 mm/min, 100mm/min, 200 mm/min, 500 mm/min). All the tests were conducted using an Instron Testing Machine. Fifteen replications were used for each treatment. The average thickness for small, medium and large almonds was 11.5 mm, 13.5mm, and 16.5mm, respectively. Fig 1 shows the shape and orientations of almond and the kernel.

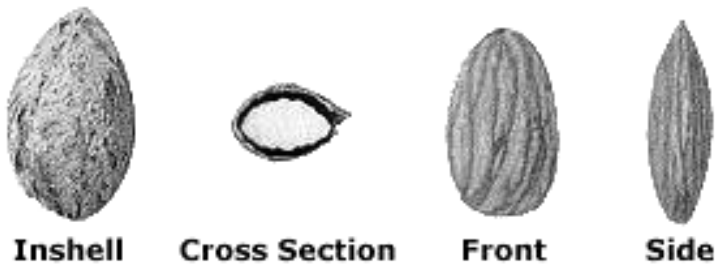

Figure 1. Shape and orientations of almond and its kernel

The absorbed energy was calculated by measuring the surface area under the force-deformation curve. The required power was calculated as follows:

$$P = \frac{E \times V}{60000 \times \Delta \ell} \quad (3)$$

where: P = Required power for cracking, W

E = Absorbed energy, mJ

V = Loading rate, mm/min

$\Delta \ell$ = Deformation upto cracking point, mm

Water uptake of kernel during soaking was determined by placing 3 samples (10 g each, moisture content 6.46% d.b) of kernels in water. At hourly intervals, the kernels were removed from water, dried using facial tissue, and then weighted. The moisture content of the samples at each measurement interval hours was determined from the relationship:

$$MC_t = \frac{m_t - m_o}{m_o}$$

where: MC_t = Moisture content of the sample t hours after immersion, d.b

m_t = weight of sample at t time, g

m_o = dry weight of the sample, g

The rate of variation of weight increase samples at any hours after immersion calculated as shown below:

$$\frac{dm}{dt} = at^k$$

where: $\frac{dm}{dt}$ = variation rate of weight increase (g/hr), and a and k are constant coefficients.

Measurements were carried out over 18 hours, the water uptake data over time was modelled empirically. Empirical models were also developed expressing relationships among the three dimensions (length, width and thickness) of almond as well as its kernel. For each dimension of almond and kernel the parameters of central tendency namely mean, maximum, minimum, standard deviation, mode, median and coefficients of skewness and kurtosis were also quantified.

RESULTS

Force, absorbed energy and required power for cracking almond

Results of the variance analysis and values of cracking force, absorbed energy and required power are presented in Tables 1 and 2. Tables 3 and 4 shows the results of Duncan's Multiple Tange Test at 0.01 significance level for a comparison of the parameters' average at different loading rates, direction of loading, and almond dimension, respectively. Figs 2 and 3 show that increasing loading rate for both loading directions reduces the amount of force required to crack the almond.

Table 1. Summary of results from analyses of variance

Source	df	Cracking force	Absorbed energy	Required power
Replication	23	7757360**	8772434**	132**
Loading rate(L)	3	5287905**	411741ns	100**
Almond dimension(A)	2	1216163**	4860511**	14.4**
Loading direction(D)	1	707560**	1855455**	4.66**
AD	2	71791ns	1051163**	1.9*
DL	3	26815ns	134966ns	3.5*
LA	6	92321ns	346933ns	6.8**
LAD	6	354803ns	111661ns	0.68ns
Error	336	14951492	20178050	102.5

**significant at 1% significance level, * significant at 5% level and ns not significant.

Table 2. Cracking force, absorbed energy and required power for cracking almond.

	Mean	Max	Min	Std
Cracking Force, N	600	1526	139	251
Absorbed Energy, mJ	496	2093	70	283
Required Power, W	0.864	5.121	0.015	0.809

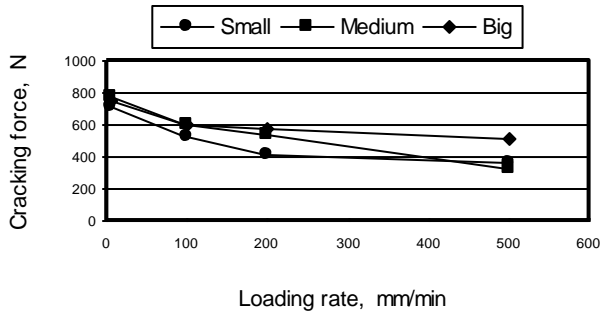

Figure 2. Effect of loading rate and almond dimension on cracking force; Direction of loading from front

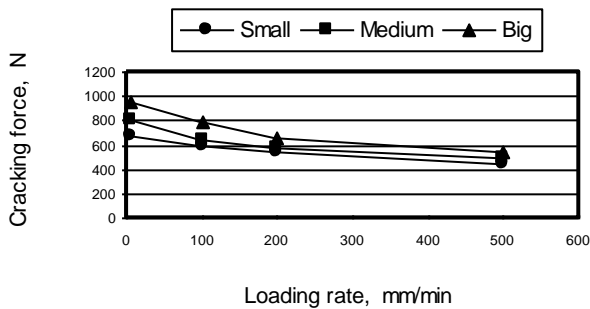

Figure 3. Effect of loading rate and almond dimension on cracking force; Direction of loading from side

The difference between cracking force at 100mm/min and 200mm/min loading was not significant but the effects at other loading rates differed significantly. The average cracking force at the loading rates of 5 mm/min and 500 mm/min were 778 N and 446 N, respectively. Figs 2 and 3 show that the cracking force increased with increasing almond dimension. The mean cracking force for large and small almonds were 647N and 533 N, respectively. Table 4 shows that the difference between cracking force for small and

medium almonds was not significant at $P=0.01$. The higher cracking force for large almonds may be explained by their thicker shell.

Table 3. Effects of loading rate on force and power required to crack almond.

Loading Rate mm/min	Cracking Force N	Absorbed Energy mJ	Required power W
5	778a	540a	0.041d
100	626b	482a	0.806c
200	549b	450a	1.148b
500	446c	514a	1.459a

Table 4. Effects of almond size on force and energy required for cracking.

Almond Dimension	Cracking Force N	Absorbed Energy mJ	Required power W
Small	533b	338b	0.593b
Medium	592b	538a	0.925a
Large	674a	613a	1.073a

The direction of force loading significantly affected ($P=0.01$) the amount of force required to crack almonds. The average cracking force for loading in side and front directions were 644 N and 555N, respectively. Figs 4 and 5 show that the absorbed energy for cracking almond was reduced with increase in the loading rate. However, the effect of loading rate on absorbed energy was not significant at $P=0.01$.

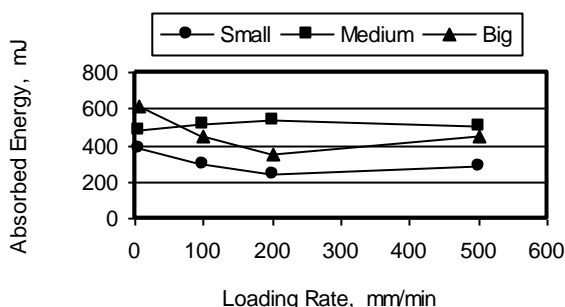

Figure 4. Effect of loading rate and almond dimension on absorbed energy for cracking; Direction of loading from front

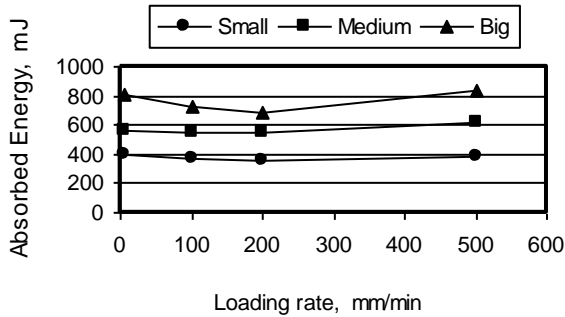

Figure 5. Effect of loading rate and almond dimension on absorbed energy for cracking; Direction of loading from side

The absorbed energy for cracking of almond was maximum at loading rate 5 mm/min, with average 540 mJ, and minimum at loading rate 200 mm/min, with average 450 mJ. Almond dimensions as well as direction of loading significantly affect the amount of energy absorbed during cracking. Large almonds absorbed more prior to cracking. However, the difference between absorbed energy for large and medium size almonds was not significant at $P=0.01$. The absorbed energy for loading from side direction, with an average of 568 mJ, was higher than that for loading from front direction with an average of 424 mJ. Figs 6 and 7 show that with an increase in the loading rate and almond dimension the required power for cracking almond was increased. The difference between the four levels of loading rates studied was statistically significant at $P=0.01$. As shown in Table 4 large and medium almonds did not differ in the amount of power required crack; however, the effect of the direction of load applied was significant for this parameter.

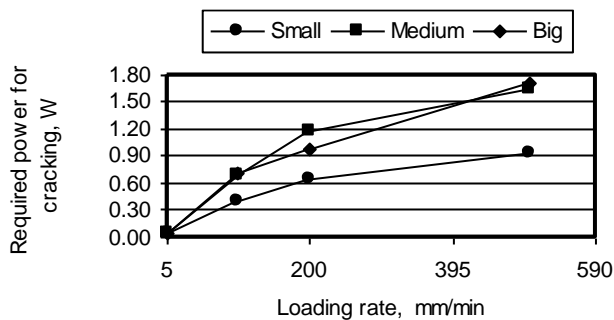

Figure 6. Effect of loading rate and almond dimension on required power for cracking; Direction of loading from front

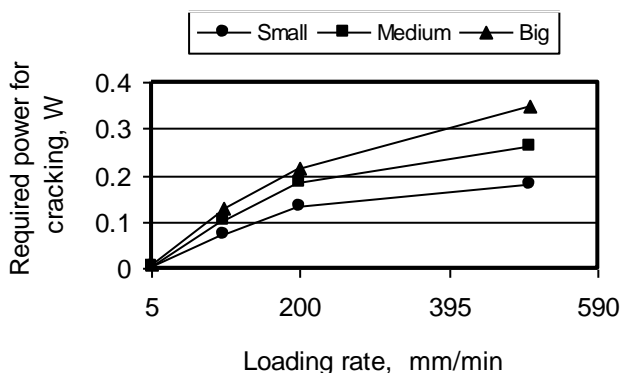

Figure 7. Effect of loading rate and almond dimension on required power for cracking; Direction of loading from side

MATHEMATICAL MODELS FOR WATER ABSORPTION OF THE ALMOND KERNELS

The variation of moisture content of kernel with time is shown in Fig 8. It is evident that immersed kernel had rapid moisture uptake at the start of immersion. Moisture content increased from 6.46% to 20.24% following 1 hour of soaking. Thereafter, the rate of water uptake declined gradually (Fig. 9). Versavel and Muir (1988) reported similar result for wheat grains.

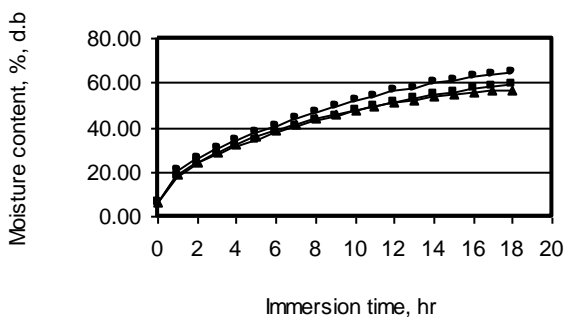

Figure 8. Relationship between moisture content of kernel with immersion time in water

The mathematical model for describing the variation of moisture content of kernels over time is as follows:

$$MC_t = 14.942 \ln t + 13.561 \dots \dots \dots R^2 = 0.99$$

where: MC_t = Moisture content, %, d.b
 t = Immersion time, hr

According to Fig. 9 the mathematical model for describing the variation rate of weight increase in samples for every hours after immersion, is as follows:

$$\frac{dm}{dt} = 11.23 t^{-0.8049} \dots \dots \dots R^2 = 0.94$$



Figure 9. Rate of water uptake in kernel with time

RELATIONSHIP AMONG THE THREE DIMENSIONS IN ALMOND AND IN ITS KERNEL

Figs 10 and 11 show the relationship among the three dimensions in almond and in its kernel, respectively.

Mathematical expressions for relationship among Three dimensions in almond and in kernel are as follows:

$$W_A = 0.172L_A + 0.839T_A + 2.258 \dots \dots \dots R^2 = 0.75$$

$$W_K = 0.206L_K - 0.198T_K + 8.282 \dots \dots \dots R^2 = 0.40$$

Where: T_A , L_A , W_A = Thickness, length and width of almond respectively, mm

T_k , L_k , W_k = Thickness, length and width of almond kernel respectively, mm

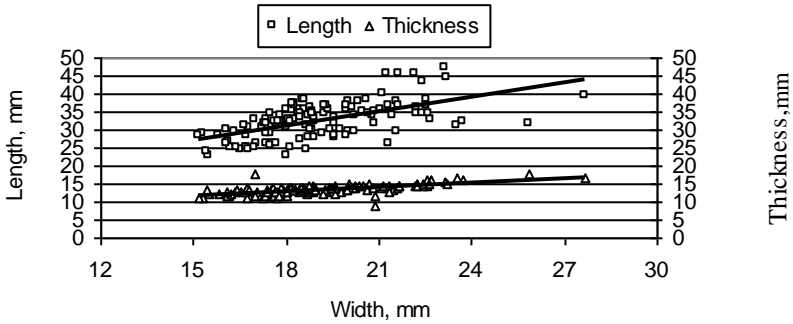

Figure 10. Relationship among three dimensions of almond

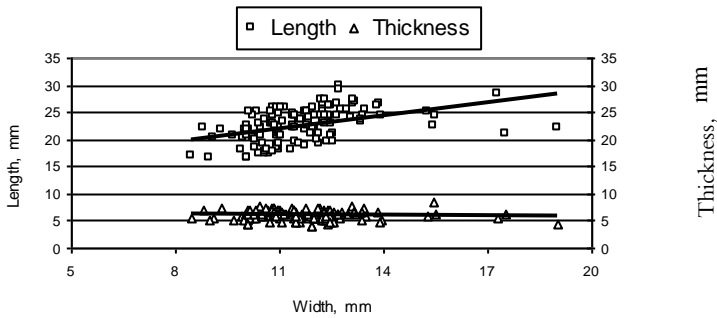

Figure 11. Relationship among three dimensions of almond kernel

Mathematical expressions for relationship between each almond dimension with its equivalent dimension in kernel are as follows:

$$L_K = 0.537L_A + 5.214 \dots \dots \dots R^2 = 0.90$$

$$W_K = 0.529W_A + 1.535 \dots \dots \dots R^2 = 0.79$$

$$T_K = 0.183T_A + 3.658 \dots \dots \dots R^2 = 0.28$$

The size characteristics of almond as well as kernel are shown in Table 5. The results shown that the distribution of data in an interval ($\mu \pm 1\sigma$) for width, thickness, and length were 67%, 72.6% and 71%, respectively. These results indicate that almond thickness had

the highest kurtosis coefficient, indicating that data compaction around the mean thickness was highest as compared with other dimensions. However, the length dimension had the least values for kurtosis and skewness coefficient (Fig. 12).

Table 5. The value of central tendency parameters for dimensions of almond and its kernel

		Mean mm	Min mm	Max mm	Mode mm	Median mm	Std mm	Skewness	Kurtosis
Almond	Width	19.11	18.77	18.85	15.2	27.65	2.21	0.46	1.05
	Thickness	13.44	13.42	13.6	9.15	18.05	1.31	0.045	1.71
	Length	32.43	32.5	32.5	22.85	47.15	5	-0.042	0.31
Kernel	Width	11.72	11.57	11	8.45	19	1.6	0.28	4.4
	Thickness	6.12	6.2	6.4	3.95	8.35	0.87	-0.27	-0.43
	Length	22.61	23	24.45	15.2	29.7	2.99	-0.39	-0.79

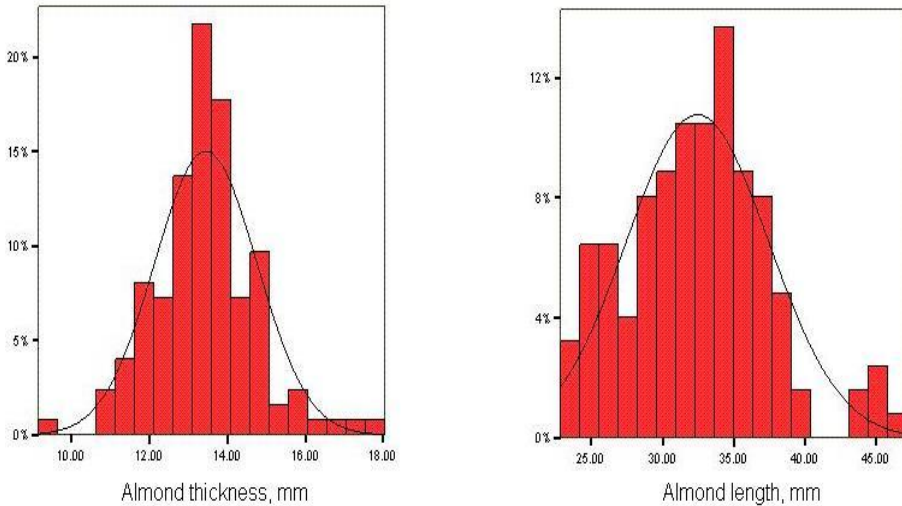
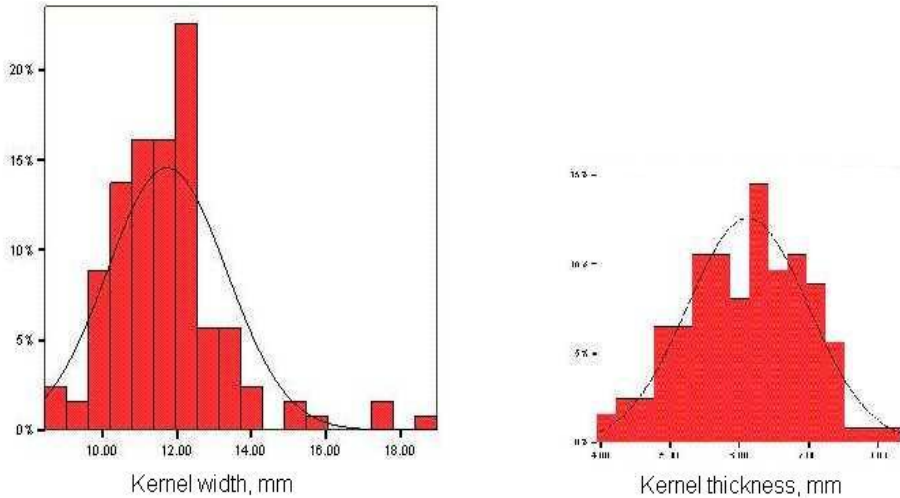

Figure 12. Frequency curves for dimensions of thickness and length of almond

The distribution of data for width, thickness and length of kernel were 78.2%, 65.4% and 62.9%, respectively. The kernel width had the highest kurtosis coefficient with average 4.4 (Fig13). The thickness dimension had the least value for koutosis and skewness coefficient.



Figur 13. Frequency curves for dimensions of width and thickness of kernel

CONCLUSIONS

The physical and mechanical properties of almonds and kernels in relation to cracking were quantified. Results obtained from force-deformation tests showed that almond size, force loading rate and direction of loading on the almond affected the amount of force and energy required to crack the almond. Using data from hydration studies, empirical models were also developed to describe the rate of water uptake of kernels. The results showed that maximum water uptake occurred during the first hour of immersion and the rate of uptake declined gradually afterwards. These results should facilitate improvements in design for almond handling and processing.

REFERENCES

1. BORGHEI. A. M , J. KHAZAEI AND T. TAVAKOLI. (2000) Design, construction and testing of walnut cracker. AgEng Conference. Paper No: 00-PH-029.
2. BRUSEWITZ. G. H. 1975. Density of rewetted high moisture grains. Trans. ASAE. Vol (18) :935 – 938
3. HSU. K. H , C. J.KIN & L. A. WILSON. (1983). Factors Affecting Water Uptake of Soybeans During Soaking. Cereal Chem. Vol 57 : 208 – 211
4. OLOSO. A. O & B. CLARKE. (1993). Some Aspect of Strength Properties of Cashew Nuts. J. Agric. Engng. Res. Vol 55 : 27 – 43
5. SINGH.B. P. N. (1989). Model for Absorption of Liquid Water by Grains. Trans. ASAE. Vol (32) : 2067 – 2071

6. SINGH. B. P. N & S. P. KULSHRESTHA. (1987). Kinetics of Water Sorption by Soybean and Pigeonpea Grains. J. Food Sci. 1538 – 1544
7. SILBERESTAIN. D .A & V. N. M. RAO. (1977). Mechanical Properties of Peanuts at Various Temperatures and Relative Humidities. Trans.ASAE. Vol (20) : 746 – 748
8. TUNG LIANG , LOREN CHIN & JOHN B. MITCHELL. (1984). Modelling Moisture Influence on Macadamia nut Kernel Recovery. Trans. ASAE . Vol (28) :1538 – 1541
9. VERSAVEL. P. A & W. E. MUIR. (1988). Moisture Absorbtion by Wheat Spikes. Trans. ASAE. Vol (31) :1255 – 1259

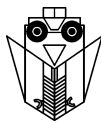

INFLUENCE OF THREE DIFFERENT RIDGERS ON YIELD OF POTATO AND RIDGE QUALITIES

FILIP VUČAJNK, TONE GODEŠA

University of Ljubljana
Biotechnical Faculty
Agronomy Department
Agricultural Engineering
Ljubljana, Slovenija

SUMMARY

Influence of three different ridgers on yield structure and ridge qualities was closely examined in our block experiment. We compared intra row rotary ridger "Grimme" driven by P.T.O., traction ridger "Hatzenbichler" with toothed rotating discs and "Bf" ridger with classical ridging bodies. Yield was the highest on plots where ridges were made by "Grimme" ridger (28,7 t/ha), then by "Hatzenbichler" (27,0 t/ha) and the lowest yield was on plots made by "Bf" ridger. Percentage of market tubers (45-65 mm, > 65 mm) is similar by "Grimme" (41,7 %) and by "Hatzenbichler" (41,8 %) and much lower by "Bf" (34,4 %). Weight of all market tubers per plant was 648 g by "Grimme", 562 g by "Hatzenbichler" and 542 g by "Bf". "Grimme" showed best results also in individual market tuber weight (100 g), in number of tubers per plant (7). Ridge area before harvest was 861 cm² (Grimme), 631 cm² (Bf), 478 cm² (Hatzenbichler) and it decreased on average for 14 % with regard to the first measuring date. Soil penetration resistance on the area of tractor trails because of spraying was significantly higher (30-40 %) in comparison with the area of no tractor trails because of spraying. Penetration resistance in soil layers in ridges also increased.

Key words: ridger, yield, ridge area, penetration resistance, potato, *Solanum tuberosum L.*

INTRODUCTION

New potato varieties achieve highest yields and the percentage of longer tubers is greater. Especially varieties of French fried potatoes are characterized by higher yields, by larger clusters and by greater number of tubers. That is why they produce too much green tubers. So ridge qualities should be adapted to the requirements of new French fried cultivars. To prevent greening of tubers, the thickness of the soil cover on the tubers should be improved. This might be done by changing the shape of the ridge or by the increase of ridge size by deeper plant bed preparation and planting, or by an increase of the row spacing to 90 cm. Farmer Klompe tried to increase the size of the ridges by deeper planting i.e. some cm below the surface of an at least 8 cm deeper plant bed and changed the shape by widening the top from 15 to 25 cm at the cost of the height of the ridge. The sides were compressed to angles of 45 °C. Therefore, size and shape of those ridges were largely maintained during the whole growing season (Kouwenhoven & Perdok, 2000).

Since the fifties up to present, ridge size could grow because furrow width is reduced to zero by early final ridging in one operation with a rotary cultivator. When ridges are made in more than one operation, e.g. for weed control on organic farms, furrow width is important to prevent penetration resistance of the sides of the ridges. Sufficiently wide furrows are easier made with a row spacing of 90 cm instead of 75 cm (Kouwenhoven & Perdok, 2000).

Larger ridges are not required for the reason that the volume of the tubers might not be accommodated in the ridge. A yield of 60 t/ha occupies only about 10 % of the space in the ridge of 700 cm². But as the tubers are concentrated around the seed tuber they are able to push the top and the sides of the ridges outwards, often followed by cracking.

METHODS

We made the block experiment with 5 replications using three different ridgers and one potato variety Carlingford on heavy soil. The entire experimental area measured 600 m². The size of one experimental plot was 10 m x 1,5 m. The first ridger was intra row rotary cultivator “Grimme 1500” driven by P.T.O. for two rows. It loosened soil very good and then it pushed the soil over the area above seed tuber. The second traction ridger was “Hatzenbichler” for two rows, which had two toothed rotating discs on each side of the row. Third one was traction two row ridger with classical ridging bodies, called Bf. It did not loosen the soil but it pushed the soil over the area above the seed tuber. The row spacing was 75 cm. Ridging was done just before emergence. With Grimme the final ridge was done in one pass, with “Bf” in three passes and with Hatzenbichler in four passes, because of very hard clay soil conditions.

Then we started to measure the ridge size on each experimental plot with device, which we developed. Measuring dates were 25.05., 05.06., 14.06., 26.06., 06.07., 26.07. and 29.08. Ridge size was measured also on ridges depressed by tractor wheels on account of fungicide spraying against potato mould.

We examined also soil penetration resistance using penetrometer with 60° nib angle. The measuring points were: the middle of the row left, the middle of the left ridge side, the

middle of the ridge, the middle of the right ridge size and the middle of the row right. Measuring of soil penetration resistance was done also on the area of tractor trails made by spraying on the left side, in the middle and on the right side of the trail.

After harvest we analysed yield and yield qualities, (yield structure, number of green, cracked, deformed tubers, starch units, dry weight, etc.) in Agricultural Institute of Slovenia.

RESULTS AND DISCUSSION

The highest yield was achieved by “Grimme” (28,7 t/ha) and it was 5,3 t higher then by “BF” ridger (23,4 t/ha). Yields were not so high as we expected because of drought in June, July and August. Starch units and dry weight are not in correlation with different ridgers (table 1).

Table 1. Yield (t/ha), starch units and dry weight (%)

Ridger	Yield (t/ha)	Starch units	Dry weight (%)
BF	23,4	14,5	22,1
HATZENBICHLER	27,0	15,4	22,5
GRIMME	28,7	15,0	22,1

Percentage of long tubers (> 65 mm) and short tubers (<25 mm) was very small, but the difference was seen by tubers 45-65 mm and by tubers 25-45 mm. Nearly the same percentage of tubers 45-65 mm was by “Grimme” and “Hatzenbichler” (41 %), but by “BF” it was 7 % lower. Very similar percentage was by tubers 25-45 mm; “Grimme” and “Hatzenbichler” (55 %) and “BF” (62,5 %) (table 2). Likely differences in yield appeared owing to ridge size and conditions in ridge, such as soil thickness above tubers, soil moisture, soil temperature, soil penetration resistance, etc. The ridge made by “Grimme” had all these conditions better than the other two; “Hatzenbichler” and “BF”.

Table 2. Percentage of yield by different tuber dimensions

Ridger	> 65 mm	45-65 mm	25-45 mm	< 25 mm
BF	0	34,4	62,5	3,1
HATZENBICHLER	0,7	41,1	55,2	3,0
GRIMME	1,0	40,7	55,9	2,4

Similar differences as by yield and yield structure were shown at weight of all market tubers per plant, individual market tuber weight per plant and number of market tubers per

plant. Weight of all market tubers per plant was in range from 542 g (Bf), 562 g (Hatzenbichler) and 648 g (Grimme). Also individual market tuber weight per plant was the highest by “Grimme” (100 g) and the lowest by “Bf” (92 g). In ridges made by “Grimme” were in average 7 market tubers per plant in contrast to ridges made by “Bf” and “Hatzenbichler” with 6 market tubers per plant (table 3).

Table 3. Weight of all market tubers per plant (g), individual market tuber weight (g) and number of market tubers per plant

Ridger	Weight of all market tubers per plant(g)	Individual market tuber weight (g)	Number of market tubers per plant
BF	542	92	5,9
HATZENBICHLER	562	93	6,0
GRIMME	648	100	6,5

Ridge area was reduced from the end of May to the end of August owing to climatic conditions (rainfall, drought). Also cracks appeared on ridges and soil was collapsed. Differences in ridge area were 116 cm² (Grimme), 108 cm² (Hatzenbichler) and 80 cm² (Bf) (table 4, figures 1, 2, 3) in comparison to first measuring date. The ridge shape was at the beginning (25.05.) rough with small clods, at the end before harvest (29.08.) however smoother.

Table 4. Ridge area (cm²)

Date	GRIMME	HATZENBICHLER	BF
25.05.	977	586	711
05.06.	956	568	683
14.06.	939	591	715
26.06.	926	580	702
06.07.	890	543	676
26.07.	876	509	651
29.08.	861	478	631

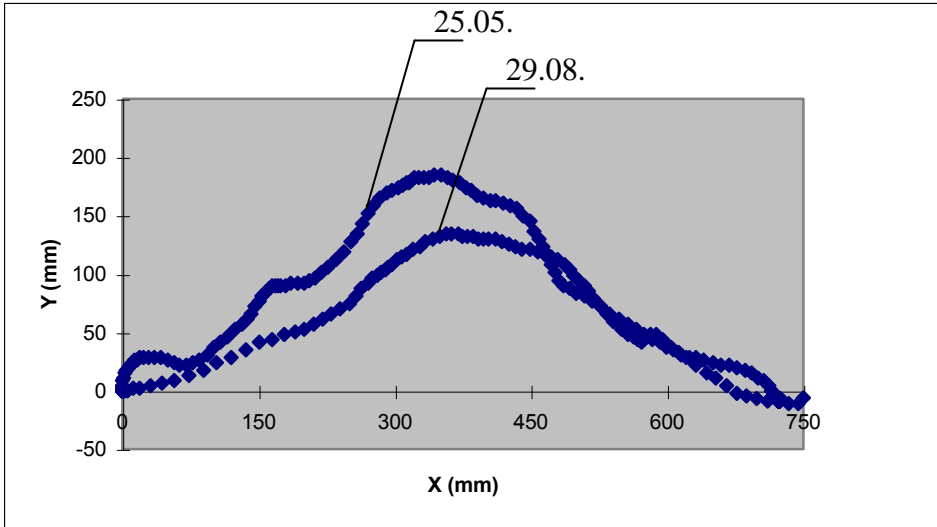

Figure 1. Ridge shape (Hatzenbichler) on experimental plot 103a

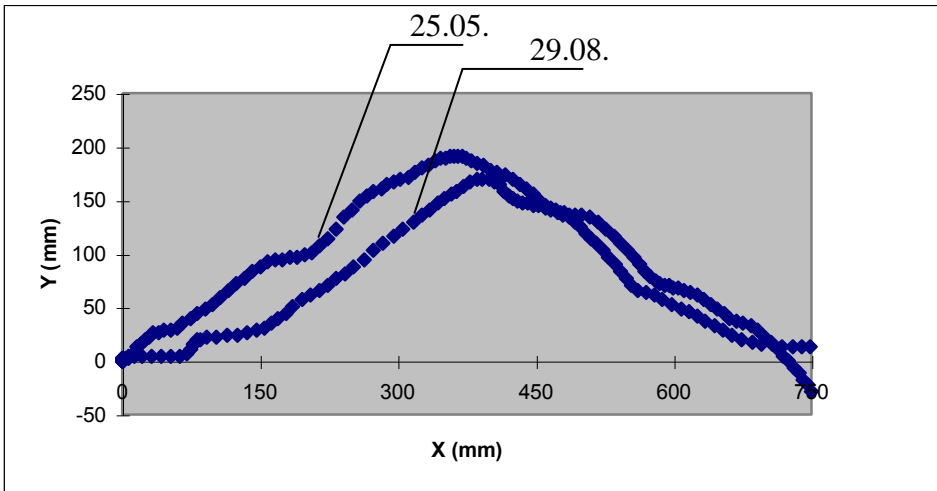

Figure 2. Ridge shape (Bf) on experimental plot 102a

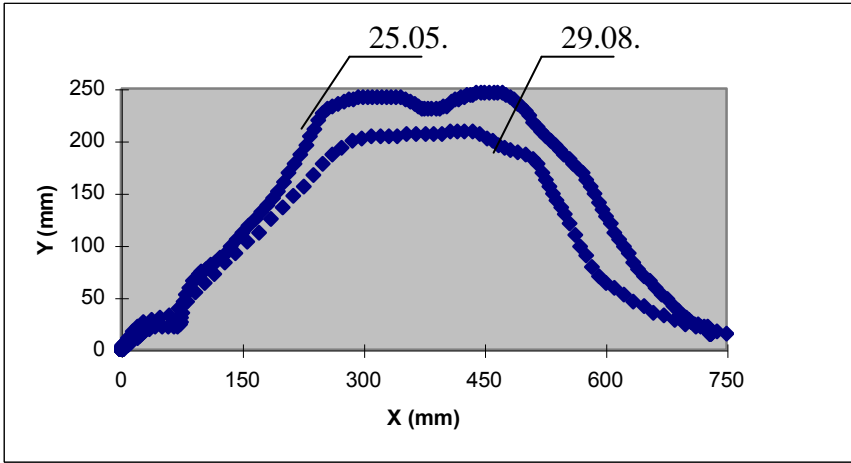

Figure 3. Ridge shape (Grimme) on experimental plot 109b

Soil penetration resistance (N/cm^2) on the area of tractor trails because of spraying was significantly enlarged from 26.06. to 29.08. Penetration resistance in upper soil layer (3,5 cm) increased from 25 N/cm^2 (15.06.) to 123 N/cm^2 (28.6.). The difference of penetration resistance started to grow from 15 N/cm^2 (3,5 cm) to 241 N/cm^2 (17,5 cm) after four fungicide sprayings (figure 4). By inter row place where there was no tractor trail because of spraying were the differences significantly lower, they ranged from 20 N/cm^2 to 164 N/cm^2 (figure 5).

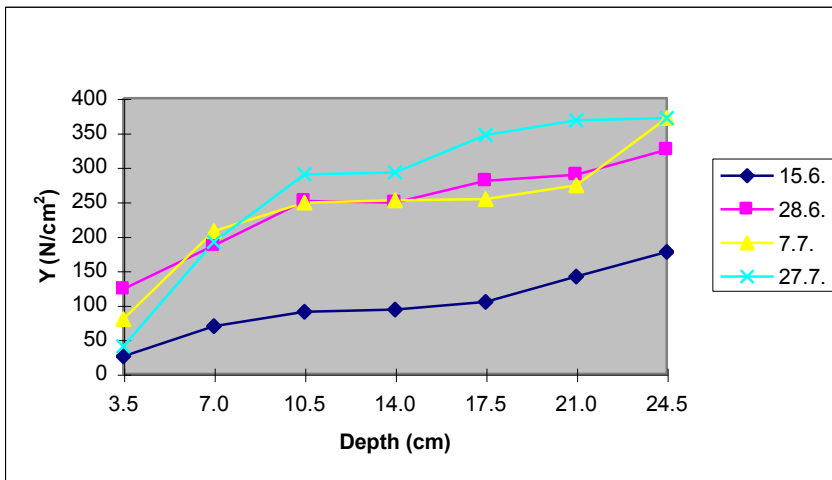

Figure 4: Soil penetration resistance (N/cm^2) on the area of tractor trails because of spraying

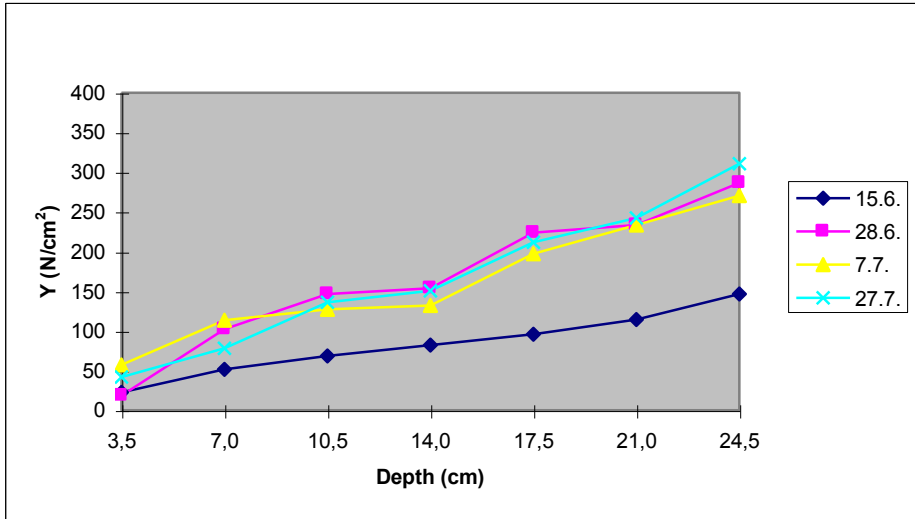

Figure 5: Soil penetration resistance (N/cm²) on the area of no tractor trails because of spraying

Interesting difference was noticed in soil penetration resistance on ridges in the middle of left and right ridge side. Grimme cultivated the soil between rows very deep and very good and that is why the soil on the ridge sides was loose and the penetration resistance was the lowest. It ranged from 52 to 271 N/cm² "Grimme" ridges (from 3,5 to 24,5 cm), from 49 to 375 N/cm² in "Hatzenbichler" ridges (from 3,5 to 24,5 cm) and from 49 to 410 N/cm² in "Bf" ridges (from 3,5 to 24,5 cm) (figure 6).

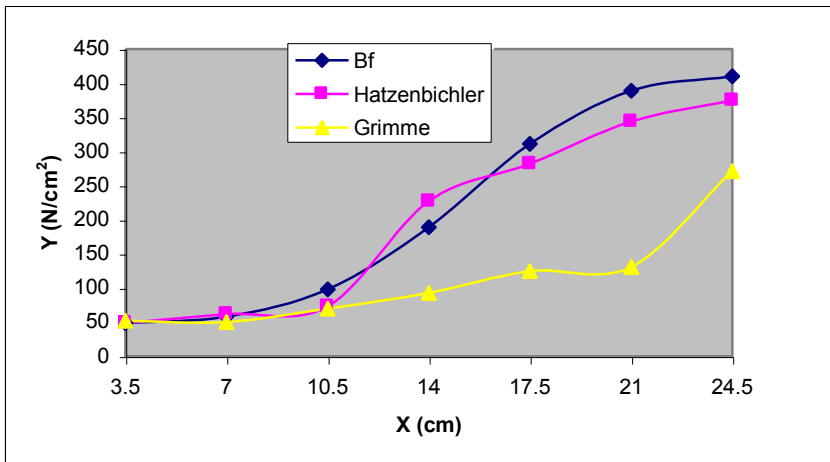

Figure 6: Soil penetration resistance (N/cm²) on ridges in the middle of left and right ridge side

Also the soil layers in ridge hardened during the growing season. The changes in soil penetration resistance were seen in the middle of the “Grimme” ridge from 14 cm and lower. It ranged from 44 to 245 N/cm² (figure 7) between 15.06. and 30.08. (before harvest).

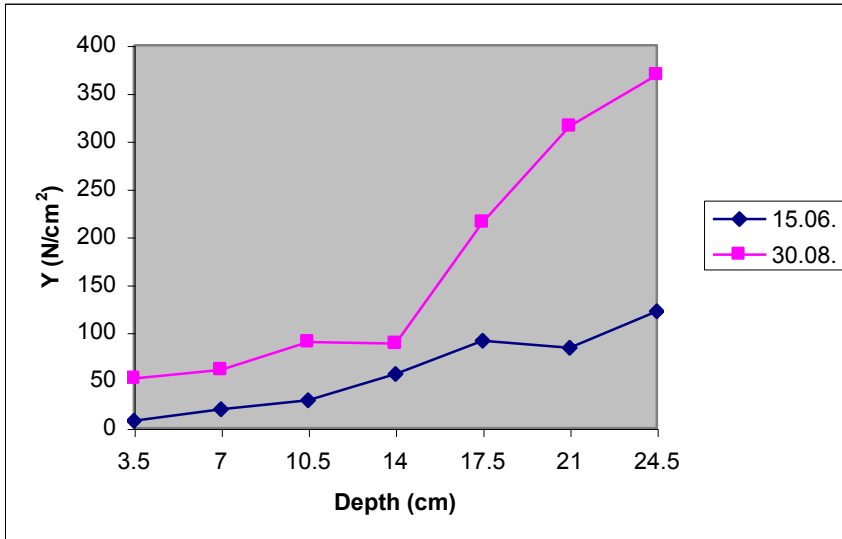

Figure 7. Soil penetration resistance (N/cm²) on ridges in the middle of the “Grimme” ridge

CONCLUSIONS

Yield of potato depends to a large extent on ridger, ridge characteristics and soil conditions in the ridge. Ridges made by “Grimme” showed the best results as we expected. Yield, yield structure, number of market tubers per plant, weight of market tuber were significantly higher as by other two ridgers. Reasons for better results are especially in great ridge area, better soil conditions in ridge and soil layers in the ridge are without clods and very loose. It must be said that growing conditions in year 2001 were bad for potato production (drought) and we will continue with trials next years. Our results show that intra row ridgers driven by P.T.O. such as Grimme are the most convenient for potato production on heavy clay soil with many clods in account of good loosening of soil. Tractorial ridger “Hatzenbichler” is better than “Bf” ridger in account of rotating toothed discs, which loose the clods and thus restores good conditions for growth and development of potato. “Bf” ridger only pushes the soil on the seed tuber. Generally ridges should be about 25 cm high and tubers should be covered by 10 to 15 cm of soil. Ridge area during the season decreases about 14 % and that is also the reason why ridge should be enough large at the beginning. The penetration resistance of soil in the ridge increases in accordance to depth during

growing season. To achieve highest yield is also important ridge area on ridges depressed by tractor wheels on account of spraying. It decreases for 27 % during growing season. The penetration resistance of soil on the area of tractor trails because of spraying is 30 to 40 % higher as on the area of no tractor trails.

REFERENCES

1. BOUMAN, A. (1998) Reihenabstand 75 oder 90 cm? – Kartoffelbau (4): s. 130-133.
2. KOUWENHOVEN, J.K., PERDOK, U.D. (2000) Ridges for new potato varieties in the Netherlands. – Wageningen University: p. 1-9.

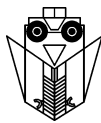

OŠTEĆENJA SJEMENA KOD RAZLIČITIH BRZINA SJETVE

STJEPAN IVANČAN, STJEPAN SITO, GORAN FABIJANIĆ

Agronomski fakultet, Zagreb
Zavod za mehanizaciju poljoprivrede

SAŽETAK

Povećanjem brzine kretanja sijačice postotak oštećenog sjemena se povećava. Najveća oštećenja 3.5 % su utvrđena kod sjetve graha pri brzini kretanja 6,0 km/h. Ova oštećenja mogu utjecati na klijavost sjemena, posebno u lošim klimatskim i zemljišnim uvjetima. Brzina kretanja do 4,0 km/h neznatno utječe na oštećenja sjemena kod sve tri istraživane kulture. Pri sjetvi kupusa oštećenja sjemena su manja nego pri sjetvi salate. Najmanja oštećenja sjemena utvrđena su kod istraživanja sijačice sa sjemenom kupusa. Do brzine kretanja 4,1 km/h oštećenja sjemena kupusa iznosila su 2.1 %, da bi kod brzine 6,0 km/h porasla na 2,5 %.

Ključne riječi: sjetva, oštećenje sjemena, grah, salata, kupus

UVOD

Proizvodnja povrća na velikim površinama zahtijeva primjenu precizne i pouzdane tehnologije, koja se može ostvariti jedino uz korištenje visokoproduktivnih strojeva, kod kojih je istodobno moguće ostvarivanje visoke razine kvalitete rada. Ovo dolazi do izražaja kod sjetve sjetve većine povrćarskih kultura. Sijačice za sjetvu povrćarskih kultura predstavljaju jednu od osnovnih točki u procesu mehaniziranja proizvodnje povrća, jer kvalitetno obavljena sjetva omogućuje široku primjenu mehanizacije kod ostalih proizvodnih procesa.

Sjetva povrća je specifična u odnosu na ratarske kulture zbog oblika, krupnoće i stranih primjesa u sjemenu, tako da se od sijačice za sjetvu povrća traži da udovolji slijedećim zahtjevima:

- mijenjanje razmaka unutar reda tj. mijenjanje gustoće sklopa, te mijenjanje razmaka redova mora biti jednostavno kako bi sijačica uspješno mogla sijati različite vrste povrća,

- oštećivanje sjemena treba biti u dozvoljenim granicama,
- put sjemena od sijačeg aparata do ulagača sjemena treba biti što kraći čime se postiže ujednačeniji razmak sjemena u redu,
- svaka sijača baterija mora biti samostalno, paralelogramski pričvršćena za okvir sijačice radi boljeg prilagođavanja neravninama terena i održavanja zadane dubine sjetve,
- sjeme treba biti zatrpano i pritisnuto rahlim tlom,
- sijačica mora omogućiti da se površinski sloj iznad sjemenki malo razrahli kako bi se prekinulo brzo isparavanje vlage iz tla.

Za udovoljavanje navedenim zahtjevima postoje tri vrste sijačica, a prema načinu transporta sjemena podijeljene su na mehaničke, centrifugalne i pneumatske. Pneumatske sijačice za sjetvu povrćarskih kultura nisu pogodne za sjetvu sjemena u kojemu ima laganih primjesa. Osim toga one su kompliciranije izvedbe, a time i skuplje.

Za naše prilike gdje sijačica treba biti univerzalna za sjetvu različitog sjemenja s obzirom na veličinu, oblik i doradu sjemenja, te jeftiniju izradu, najprikladnije su sijačice s mehaničkim sijačim aparatom. Mehaničke sijačice razlikujemo prema izvedbi uređaja za izuzimanje sjemena iz spremnika, pa postoji sijaći aparat s trakom i kolutom. Budući da za obje vrste sijačica broj i promjer rupa mora odgovarati sjetvi dotičnog sjemena, to univerzalnost sijačice ovisi o broju različitih veličina i broja rupa na traci i kolutu. S obzirom na to, lakše je i jeftinije sijačicu opremiti većim brojem traka nego kolutova, jer su trake jeftinije i lakše ih je izbušiti odgovarajućim rupama, nego takve rupe ubušiti u kolutove. Za preciznu sjetvu i kolut i traku treba izbušiti rupama prema veličini sjemena, a broj rupa prema gustoći sklopa, što sijačicu s trakom čini univerzalnijom, a time i prihvatljivijom u našim uvjetima dorade sjemenja i sjetve različitih vrsta sjemenja.

MATERIJAL I METODE RADA

Istraživanja su obavljena sijačicom Stanhay S-870. To je sijačica koja ima mehanički sijaći aparat s perforiranom trakom. Namijenjena je za sjetvu sitnog sjemena, ali se uspješno koristi i za sjetvu krupnijeg sjemena. Sijačica se sastoji od okvira, donjeg postroja, baterija za sijanje i pogonskih kotača. Na okvir je pričvršćena piramida sa svornjacima za priključke kategorije I i II, tako da je sijačica nošenog tipa. Donji stroj sijačice se sastoji od prednjeg kotača, rala ili ulagača, zagrtča sjemena, zadnjeg pritisknog kotača i uređaja za podešavanje dubine rada.

Za istraživanje je odabrano sjeme graha, salate i kupusa. Istraživanja su obavljena sjemenom navedenih kultura zato što se njihovo sjeme međusobno razlikuje po krupnoći i obliku. Sjeme graha bilo je najveće, a sjeme kupusa najmanje. Kod svake vrste sjemena istraživanja su vršena s dvije sorte sjemena različitog oblika. Utvrđivanje oštećenja sjemena pri sjetvi različitim brzinama obavljeno je na ispitnom stolu. Istraživanja su obavljena na taj način što se je za svaku ispitivanu kulturu sekcija sijačice postavila na ispitni stol gdje se je mogla mijenjati brzina izbacivanja sjemena. Brzine izbacivanja sjemena bile su podešene prema potrebi za brzinu kretanja pojedine kulture do kritične brzine gdje se bitno narušava raspored sjemena. Izbačeno sjeme je hvatano u posudu koja je bila postavljena ispod

sijaćeg rala. Trajanje pokusa bilo je od 30 do 60 sekundi, prema podešenoj brzini, odnosno kod većih brzina hvatano je sjeme u trajanju od 30 sekundi, a kod manjih brzina u trajanju od 60 sekundi. Veličina oštećenja sjemena vršena je vizuelnim putem uz pomoć povećala, a sva oštećenja sjemena podijeljena su u četiri kategorije.

1. Prva kategorija - jako oštećeno sjeme, gdje nedostaje preko 1/4 sjemena.
2. Druga kategorija - manje oštećeno sjeme, gdje nedostaje do 1/4 sjemena.
3. Treća kategorija - ogrebano sjeme.
4. Četvrta kategorija - napuknuto sjeme.

Brzine kretanja su utvrđene prema rezultatima rada sijačice u prethodnim istraživanjima, te na bazi preporuke proizvođača sijačice. Brzine kretanja bile su iste za sve istraživane kulture, kako bi se moglo utvrditi kako brzina kretanja utječe na oštećenja sjemena pojedine kulture.

REZULTATI ISTRAŽIVANJA

Najveća oštećenja zrna su utvrđena kod sjetve graha ovalnog oblika zrna i to kod brzine 6.0 km/h, a iznosila su 3.5%. Od tih ukupnih oštećenja ogrebenih zrna bilo je 1.3 %, napuknutih 1.2 %, manje oštećenih 0.6 % i jako oštećenih zrna 0.4 %. Rezultati prikazani u tablici 1 pokazuju da ima razlika u oštećenjima između okruglog i ovalnog zrna graha. Veća oštećenja zrna utvrđena su kod sjetve graha ovalnog zrna i to posebno kod povećanih radnih brzina. Najmanja oštećenja zrna su utvrđena kod sjetve graha okruglog zrna i to kod brzine 3.2 km/h, a iznosila su svega 1.6 %.

Tablica 1. Utjecaj brzine kretanja sijačice na oštećenja sjemena graha
Table 1. Effect of drill speed upon bean seed damage

Oblik sjemena Seed shape	Brzina kretanja Sowing velocity km/h	Kategorije oštećenja sjemena Seed damage category				Ukupno oštećenje Total seed damage %
		1. (%)	2. (%)	3. (%)	4. (%)	
Okruglo Spheric	3.2	0.2	0.2	0.7	0.5	1.6
	4.1	0.2	0.4	0.9	0.6	2.1
	6.0	0.5	0.3	1.2	0.9	2.9
Ovalno Flat	3.2	0.2	0.3	0.8	0.6	1.9
	4.1	0.2	0.5	1.0	0.8	2.5
	6.0	0.4	0.6	1.3	1.2	3.5

Iz prikazanih podataka u tablici 2. vidljivo je da se sjeme kod sjetve salate malo oštećuje. Nešto veća oštećenja sjemena 2.3 % i 3.1 % utvrđena su pri sjetvi kod povećanih radnih brzina i kod sjetve ovalnog sjemena. Kod sjetve salate okruglog sjemena najveća oštećenja

sjemena utvrđena su kod brzine 6.0 km/h, a najmanja 1.4 % kod brzine 4.1 km/h. Kada se usporede oštećenja sjemena po kategorijama vidljivo je da ima najviše ogrebenih i napuknutih sjemenki.

Tablica 2. Utjecaj brzine kretanja sijačice na oštećenja sjemena salate
Table 2. Effect of drill speed upon lettuce seed damage

Oblik sjemena Seed shape	Brzina kretanja Sowing velocity km/h	Kategorije oštećenja sjemena Seed damage category				Ukupno oštećenje Total seed damage %
		1. (%)	2. (%)	3. (%)	4. (%)	
Okruglo Spheric	3.2	0.2	0.2	0.5	0.8	1.7
	4.1	0.1	0.2	0.6	0.5	1.4
	6.0	0.4	0.3	0.8	0.6	2.1
Ovalno Flat	3.2	0.3	0.3	0.6	0.5	1.7
	4.1	0.2	0.2	1.1	0.8	2.3
	6.0	0.4	0.4	1.2	1.0	3.1

Navedeni podaci u tablici 3. pokazuju da povećanje brzine kretanja utječe na povećanje broja oštećenja sjemena. Najveća oštećenja sjemena utvrđena su kod sjetve kupusa ovalnog sjemena i iznosila su 2.4 % kod brzine 4.1 km/h, a 2.9 % kod brzine 6.0 km/h. Pri radu s ovom sijačicom brzina kretanja do 4.0 km/h neznatno utječe na oštećenja sjemena kupusa, dok je pri radu s većim brzinama taj utjecaj izraženiji.

Tablica 3. Utjecaj brzine kretanja sijačice na oštećenja sjemena kupusa
Table 3. Effect of drill speed upon cabbage seed damage

Oblik sjemena Seed shape	Brzina kretanja Sowing velocity km/h	Kategorije oštećenja sjemena Seed damage category				Ukupno oštećenje Total seed damage %
		1. (%)	2. (%)	3. (%)	4. (%)	
Okruglo Spheric	3.2	0.2	0.2	0.5	0.8	1.7
	4.1	0.1	0.2	0.6	0.5	1.4
	6.0	0.4	0.3	0.8	0.6	2.1
Ovalno Flat	3.2	0.3	0.3	0.6	0.5	1.7
	4.1	0.2	0.2	1.1	0.8	2.3
	6.0	0.4	0.4	1.2	1.0	3.1

ZAKLJUČAK

1. S povećanjem brzine kretanja sijačice dolazi do lošije kvalitete sjetve, a što se manifestira neravnomjernim rasporedom sjemena u redu, smanjenim sklopom biljaka i većim oštećenjem sjemena.
2. Oštećenja sjemena u procesu sjetve su različita za pojedine kulture. Najveća oštećenja sjemena utvrđena su kod sjetve graha i to kod povećanih radnih brzina.
3. Na temelju rezultata istraživanja može se uočiti da je veći postotak oštećenja utvrđen kod sjemena ovalnog oblika, a manji kod okruglog sjemena.
4. Radna brzina je osnov za kvalitetu rada, povećanje proizvodnosti, produktivnosti i ekonomičnosti. Dijapazon optimalnih brzina treba odrediti za svaku kulturu posebno, kao i za vrijeme i uvjete rada.

LITERATURA

1. BRČIĆ J., DUJMOVIĆ M., (1970) Mehanizacija u povrćarstvu, Zagreb.
2. ČULJAT M., (1986) Sijačice za okopavine, Agrotehničar br. 3, Zagreb.
3. HAFRAT W., (1990) Faktoren für die Ablagegenauigkeit von Einzelkornsamaschinen, Praktische Landtechnik.
4. IVANČAN S., (1991) Utjecaj brzine rada sijačice na kvalitetu sjetve šećerne repe, Zbornik radova Aktualni zadaci mehanizacije poljoprivrede, Pula.
5. PAVLEK P., (1970) Specijalno povrćarstvo, Zagreb.
6. TODORIĆ I., BOROŠIĆ J., (1990) Sjetva sitnozrnatog sjemenja povrća, Zbornik radova Aktualni zadaci mehanizacije poljoprivrede, Opatija.

SEED DAMAGE AT VARIOUS DRILL SPEEDS

SUMMARY

The higher the drill speed, the higher is the percentage of damaged seeds. The highest proportion of damage (3.5%) was recorded in bean seeding at a speed of 6.0 km/h. Such damage may affect seed germination, particularly in adverse climatic and soil conditions. Speed increase to 4.0 km/h had a negligible effect upon seed damage in all three studied crops. Seed damage was lower in cabbage seeding than in lettuce seeding. Lowest seed damage was determined in trials with the cabbage seed drill. Up to the working speed of 4.1 km/h, damage to cabbage seed was 2.1 %, which rose to 2.5 % at a speed of 6.0 km/h.

Key words: *seeding, seed damage, bean, lettuce, cabbage*



REAL-TIME MONITORING SYSTEM OF REARING CONDITIONS FOR SILKWORM PRODUCTION

MINZAN LI, MASANOBU OHURA *

China Agricultural University
Beijing, China

*National Institute of Agrobiological Sciences
Tsukuba, Japan

SUMMARY

To create a system that utilizes silkworms to produce new materials and functional substances, we are conducting research to develop an automated silkworm rearing system working under clean air conditions. As a part of the project, we set up a remote control system that performed real-time monitoring and control of the rearing apparatus from remote places by means of the Internet. The monitoring and control system consists of two sub-systems: a remote rearing condition monitoring system, and a remote rearing temperature and humidity measurement system. The remote rearing condition monitoring system employs a live camera to capture images of silkworms in the rearing room continuously, and a network camera server to send these digital images over by the Internet. The remote rearing temperature and humidity measurement system, which consists of a control computer with Web browser and a rearing environment measurement control system, enables the real time observation of the rearing temperature and humidity from remote places via the Internet. The experimental results of the monitoring and control system tests showed that the rearing information, such as growing status of silkworms, rearing temperature and rearing humidity, can be well understood from a distance. Hence, optimal management of a large-scale silkworm rearing facility could be conducted remotely and automatically by these systems.

Key words: *sikworm production system, Internet, rearing condition monitoring, automatic control.*

INTRODUCTION

It is an important project to create new materials and functional substances from insects such as silkworm and bee. For this purpose, it is necessary to develop an automated system for large-scale and low-cost insect rearing, which can protect rearing insects from contaminant throughout a year. Thus, we have developed a silkworm rearing environment control system (Peng and Ohura, 1999), an automated silkworm rearing machine (Ohura, et al. 1999), and an automated artificial diet feeding system (Ohura and Li, 2001). The automatic rearing machine consists of a control computer, a control sequencer, a rearing house and a movable lift. The rearing house unit has four columns, with six layers and 20 rearing trays. By using the movable lift set by the rearing house unit, circulation and movement of rearing trays can be performed. These systems make it possible to rear silkworms automatically under clean air conditions.

On the other hand, in order to execute optimal rearing management, it is necessary to understand the operation conditions of the rearing system and growing situation of silkworm larvae continuously, under the condition that operator does not have to enter the rearing room. In line with the development of information technology, it is also desirable to perform such management, and if possible, control, from remote places away from the rearing room. Thus, to achieve these goals, we developed a remote monitoring and control system. This system can monitor the rearing conditions in real-time from remote places via the Internet, and can measure the rearing environment parameters such as rearing temperature and humidity from a distance.

METHODS AND MATERIALS

Figure 1 outlines the developed remote monitoring and control system. It can be separated into two sub-systems. One is a remote rearing condition monitoring system that captures images of silkworm larvae in the rearing room continuously and send the images to the Internet automatically. The other is a remote rearing temperature and humidity measurement system for the control of the rearing environment from a remote place using a Web browser.

RESULTS AND DISCUSSION

Remote Rearing Condition Monitoring System

Construction of the remote rearing condition monitoring system:

Figure 2 shows a schematic diagram of the remote rearing condition monitoring system. It is composed of a live camera (VC-C4R, Canon Inc., Tokyo, Japan) set up in the rearing room and a network camera server (VB-101, Canon Inc.).

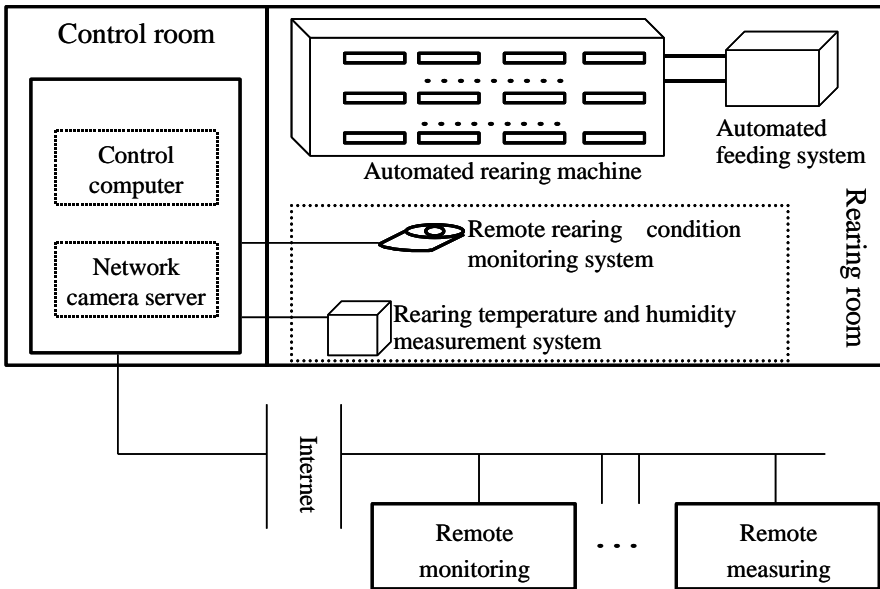

Figure 1. Schematic diagram of the remote monitoring and controlling system

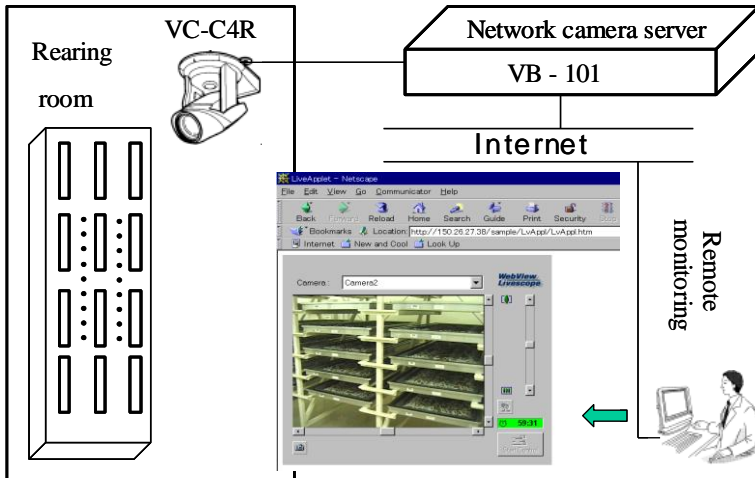

Figure 2. Schematic diagram of the remote rearing condition monitoring system

The live camera is used to capture images of silkworm larvae in the rearing room. It has a 16x zoom lens and function for rotating 360 degrees in any direction. The total number of pixels is 410,000, and effective pixels 380,000. The resolution is 460 TV lines (horizontal) and 350 TV lines (vertical). The scan mode is interlase (60 field / 30 frame). In addition, it has three output terminals, a video output terminal, an S-video output terminal, and an RS-232C I/O terminal.

The network camera server converts the images into digital data and sends over the Internet. It is fully compatible with the live camera VC-C4R. The specifications of the camera server are as follows. Communication protocol: TCP/IP, HTTP, and FTP; Video compression method: Motion-JPEG (Quality can be varied from 1 to 99) / JPEG (for still image); Video compression rate: 30 fps (max); Serial interface: RS-232C X 3 (DIN8, two for camera control, and one for initial setting); Network interface: Ethernet X 1 (RJ45, 10/100 Auto-switching).

The camera server can not only transmit images over the Internet, but also receive camera control commands from the image receiver in the same way, and then change the camera angle and zoom ratio as requested.

Furthermore, the camera server can record still picture images of the rearing conditions, if necessary. The pictures are stored in a flash memory card, to be transmitted over the Internet or edited by a personal computer.

Web page for monitoring rearing condition of silkworms:

In order to monitor the rearing conditions of silkworms over the Internet, a Web page was created. Using the Web page, rearing images of silkworms can be viewed, and the rearing temperature and humidity of silkworms can be monitored. Figure 3 (a) shows the Web page.

There are two ways to view the images of rearing conditions from remote places: One is called Fast Manner; the other is called Normal Manner.

If Fast Manner is used, a viewing platform needs to be pre-installed so that the viewing window can be started rapidly. When the "Fast Manner" button is clicked on the Web page, images of the rearing conditions are displayed as shown in Figure 3 (b). Using the scroll keys, viewing angle and zoom of the camera can be adjusted. In addition, the size of the image can be changed as required.

If "Normal Manner" button is used (as shown in Figure 3(c)), the viewing platform does not need to be installed, so the rearing conditions can be monitored anywhere from a Web browser. However, there may be some delay before the first image is displayed, since a Java program needs to be downloaded first. In addition, the size of the image on the users side on the Web browser cannot be changed.

On this Web page, clicking the "Still Image" button as shown in Figure 3(d) can retrieve stored image data. By setting retrieval conditions, appropriate images can be searched for, and then copied and edited.



(a)

(b)

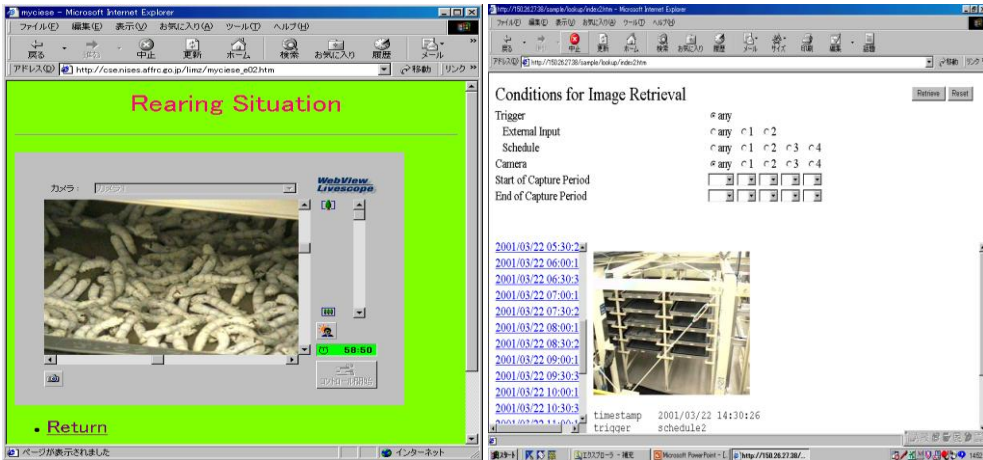

(c)

(d)

Figure 3 Web pages for monitoring rearing condition of silkworms

Remote Rearing Temperature And Humidity Measurement System

The rearing temperature and rearing humidity are important parameters of the rearing environment. A fully automated environmental control system for insect production has been developed (Peng and Ohura, 1999). By adding a mail server this system was further developed into a remote measurement and control system (Peng and Ohura, 2000). However, in this case it is needed to pre-install a program on the remote computer, which was specially written for this purpose. Thus, in this study we developed a remote rearing environment measurement system, which can be conveniently operated via a Web browser

so that the rearing temperature and humidity can be observed without requiring the pre-installed special program from a remote place.

Remote measurement of rearing temperature and humidity:

To obtain environmental information of the rearing room from a remote place via a Web browser, it is required to have a system to send the information to the Internet at the rearing room and another to receive the information via a Web browser at the site of the remote observer.

The data receiving software was coded in Microsoft VB 6.0, and the MAPI control protocol of VB was used to read messages from the Internet and send reply data to the rearing room immediately. Outlook Express by MS was used as the interface to transmit information data of the rearing temperature and humidity between the rearing room and observer. Figure 4 shows the flowchart of the control program.

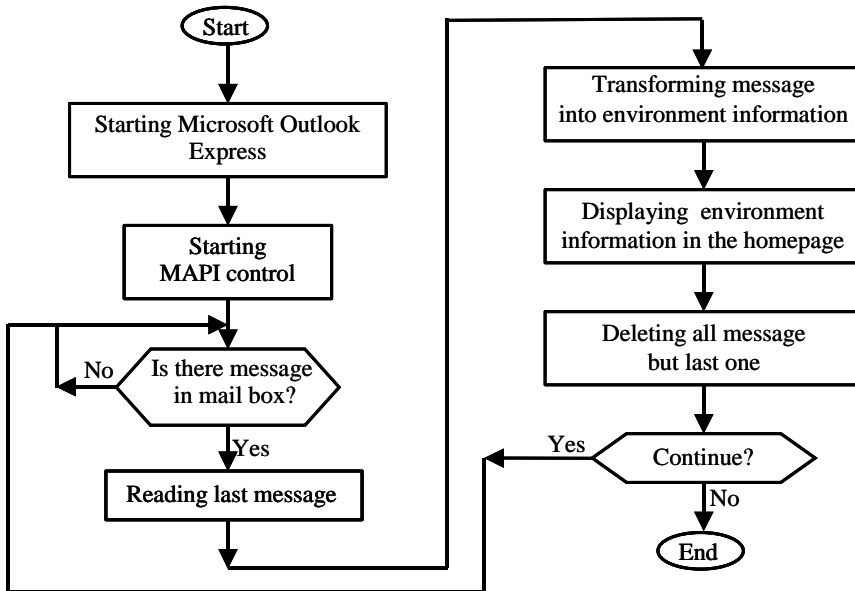

Figure 4. Flowchart of program for the remote rearing temperature and humidity measurement system

When the program is started at a remote place, temperature and humidity data are checked by the Outlook Express mail system. Then, the last message is read and transformed to environmental information, and the rearing temperature and humidity are displayed on the Web page. The interval between reading a measuring message and displaying information can be set in real time.

This program is linked to the Web page shown in Fig. 3(a) so that the rearing temperature and humidity can be checked from a remote place.

Displaying of rearing temperature and humidity on the web page:

The program was edited to display the rearing temperature and humidity on the Web page. When the “Rearing Temp.” and ”Rearing Humi.” buttons are clicked on the Web page shown in Figure 3(a), the rearing temperature and humidity are displayed as graphs. Figure 5 shows the time series of rearing temperature.

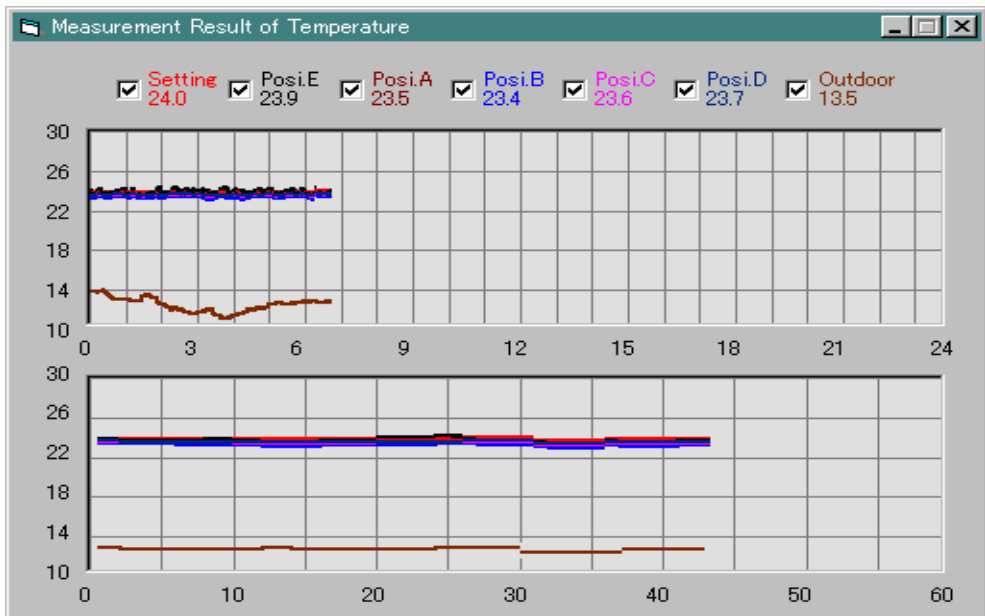

Figure 5. Rearing temperature shown in a remote place

Data of rearing temperature are displayed in two graphs, at 24-hour interval (top) or 1-hour interval (bottom). In each graph, seven lines are displayed: setting temperature, outdoor temperature, and the temperatures at different positions inside the rearing room where the temperature-humidity sensors are located. In addition to the lines, temperatures could be viewed numerically by clicking the appropriate check box.

The rearing humidity can also be measured in the same way as rearing temperature.

CONCLUSION

To create a system that utilizes silkworms to produce new materials and functional substances, we are conducting research to develop an automated silkworm rearing system

working under clean air conditions. As a part of the project, we set up a remote control system that performed real-time monitoring and control of the rearing apparatus from remote places by means of the Internet. The monitoring and control system consists of two sub-systems: a remote rearing condition monitoring system, and a remote rearing temperature and humidity measurement system.

The remote rearing condition monitoring system employs a live camera to capture images of silkworms in the rearing room continuously, and a network camera server to send these digital images over by the Internet. As the basis of optimal rearing management of silkworms, it is necessary to monitor the rearing conditions of silkworms in real time without interference. Since any object can be observed by operating the camera via a Web browser from a remote place by this system, the silkworm rearing conditions, such as growing status, behavior and presence of artificial diet, can be monitored from anywhere at any time.

The remote rearing temperature and humidity measurement system, which consists of a control computer with Web browser and a rearing environment measurement control system, enables the real time observation of the rearing temperature and humidity from remote places via the Internet, and thus the operator can determine whether the silkworms are in optimal rearing conditions. The measurement results provide the basis for optimal rearing management of silkworms. The system makes it easy to automatically carry out large-scale silkworm rearing at low cost, and to execute remote environmental control of the rearing room.

REFERENCES

1. OHURA, M., PENG, Y.K., NINAGI, O., (1999) Development of an automatic rearing machine for the fifth instar larvae of the silkworm, *Bombyx mori*. J. Seric. Sci. Jpn, Vol.68, pp 245-251.
2. OHURA, M. LI, M., (2001) Automatic artificial diet feeding system for rearing silkworm, *Bombyx mori*, J. Insect Biotechnology & Sericology, Vol.70, pp 59-62.
3. PENG, Y.K., OHURA, M., (1999) Development of measurement and control system of rearing environment for insect factory (II) Temperature and humidity control of silkworm rearing room. J. JSAM, Vol.61, No.4, pp 151-158.
4. PENG, Y. OHURA, M. (2000) Remote automated environment control system for insect production, Applied Engineering in Agriculture, Vol.16, No.6, pp 715-721



THE TEMPERATURE CONDITIONS IN UNINSULATED COWSHED

BRONIUS KAVOLELIS

Lithuanian Institute of Agricultural Engineering
Kaunas, Lithuania

SUMMARY

In Lithuania the cold loose housing systems for dairy cows have been built during the last few years. Now cows are kept within a cubicle housing system with straw bedding or in deep litter house. The aim of this work is to analyse the conformance of Lithuanian uninsulated cowsheds development with the global trends, to estimate climatic conditions of uninsulated cowshed, intensity of ammonia emission. Technological and technical solutions of uninsulated cowsheds built in Lithuania are analogous to those applied in West Europe. Average daily outside air temperature during the research period varied from +10 °C to -14 °C. By analytical and experiment tests we determined that the calculated value of indoor and outdoor air temperatures difference is 4 °C, and the indoor air relative humidity is about 5 % lower than that of outdoor air. According to experiments air quality to be higher in uninsulated cubicle cowshed than the traditional one. Ammonia evaporation intensity in uninsulated cowshed is 30 % lower than in the insulated one, and per one animal place it makes 14 and 20 g per day, correspondingly.

Key words: *uninsulated cowshed, temperature, relative humidity, ammonia emission, mathematical model.*

INTRODUCTION

Construction of uninsulated (cold) cowsheds has been on an increase in Europe lately (Brehme 1999). Experimental findings of recent years (Epinatjeff 1997) suggest that the most suitable temperature for a productive cow is from 5 °C above zero to 10 °C below zero. A marked reduction in milk yield occurs only when the temperature exceeds 24 °C above zero and when it drops below 27 °C subzero. It is asserted that a cowshed has to be cheap. It is enough to protect the stock from the wind and precipitation. Capital insulation of a building means not only heavy costs but also a hindrance for flexible changing of

livestock housing technology. Temperature and air humidity in the cowshed can be close to the outdoor temperature and moisture. However, it is important that the premises are well-aerated, livestock is protected from the wind, and soft and dry den is provided. Due to a higher livestock productivity and better health, milk production in cold cowsheds is more profitable than that in insulated cowsheds, which are common in our country. Although, for example in Germany, most of the currently built cowsheds are uninsulated cubicle-type (Suhr et al. 1999), deep or with sloping floors uninsulated cowsheds are cheaper than cubicle-type ones (Pöllinger 1998). Appropriate ventilation of a cowshed is increasingly winning attention. Most often natural ventilation system is installed, and a spacious cowshed is built, as great space promotes self-ventilation of the shed. In order to increase the space from 30 m³ to 40-50 m³ per cow, the roof inclination should be increased from minimum 16° to 22-24°.

The attitude towards cow housing is changing in Lithuania. The first cold cubicle-type was built in 1999, and in 2000 a few cold deep cowsheds.

The objectives of the present study are to analyse the conformance of Lithuanian uninsulated cowsheds development with the global trends, estimate climatic conditions of uninsulated cowshed, intensity of ammonia emission.

OBJECTS AND METHODS

The object of our studies and analysis were uninsulated cowsheds constructed in Lithuania over the recent years. The following types of cowsheds were investigated:

- cubicle-type, housing 80-200 cows. The pens are littered by straw. Average heat transfer coefficient of walls and roof $k=4.5$ W/m² K. One cow gets 7 m² of cubicle and walking area and 35 m³ of space. Manure is removed by a scraping transporter or a tractor bulldozer. Clean air flows in through the gaps at the top of longitudinal walls and contaminated air is removed through the gap of the ridge;
- deep, housing 120 cows. Walls and roof $k=4.0$ W/m² K. One cow gets 7 m² of den area, 9 m² of den and walking area and 57 m³ of space. Clean air flows in through the windows covered with a net, and contaminated air is removed through the gap of the ridge.

Using analytical and experimental methods we worked out a mathematical model of the criterion describing air quality in the cowshed and weeping of inner surface of barriers - the difference of indoor and outdoor temperatures.

By experimental tests we determined microclimatic conditions in cowsheds, intensity of ammonia emission. While processing the experimental data by the regression analysis method we determined the relationship between indoor and outdoor climatic factors necessary for cold cowsheds, as well as for designing and exploitation of their ventilation systems. By comparing analytical and experimental data we verified if the intensity of cowshed ventilation was adequate. Comprehensive investigations were carried out at AC “Lumpenai Rambynas” cubicle-type cowshed, and in the other cowsheds we performed observations of production scale. The obtained data were compared with the analogous data from an insulated cowshed.

During our experiments we measured major microclimatic parameters of the indoor air (temperature, relative air humidity, ammonia concentration, air movement velocity), outdoor air climatic parameters (temperature, relative air humidity, wind velocity).

For the investigation of ammonia emission we used the methods of mass flow (Carlson et al. 1994) and indirect, according to calculated ventilation intensity (Pedersen et al. 1998).

During the period investigations outdoor air temperature varied from +10 to -14 °C.

RESULTS

Mathematical model of the difference of indoor and outdoor temperatures

In order to prevent condensation of water vapour on the inner surface of external barrier it is necessary to maintain the temperature in the cowshed, which is found from the following equation

$$t_r \leq \tau = t_p - \frac{k}{\alpha_p} (t_p - t_l) \quad (1)$$

where

t_r - dew point temperature inside air, °C;

τ - temperature of the internal surface of the external barrier, °C;

t_p - inside air temperature, °C;

t_l - outside air temperature, °C;

k - coefficient of the heat transmission of the external barrier, W/m² K;

α_p - coefficient of heat transfer of the internal surface of the barrier, W/m² K.

From equation (1) we find permissible difference of temperatures

$$\Delta t \leq \frac{\alpha_p}{k} (t_p - t_r) \quad (2)$$

The indoor and dew point temperatures will be found with its moisture by the regression equation. Having statistically processed physical air data we see that the highest (saturation state) water vapour content in per unit of air mass d , g/kg, also depends on its temperature t , °C,

$$d = 3.82 \cdot 1.08^t \text{ when } (-20 \leq t \leq 5) \text{ °C.} \quad (3)$$

From equation (3) we find that the indoor air temperature

$$t_p = 29.9 \lg d - 17.43 \quad (4)$$

Actual content of water vapour per unit of indoor air mass

$$d_p = d \varphi_p = 3,82 \cdot 1,08^{t_p} \quad (5)$$

where

φ_p - relative humidity of indoor air, in parts of unit.

Then the indoor air dew point temperature

$$t_r = 29.9 (\lg d + \lg \varphi_p) - 17.43. \quad (6)$$

Having worked out equations (2), (4) and (6) we see that in order to prevent condensation of water vapour on the inner surface of exterior barriers of the cowshed it is necessary to maintain the following difference between indoor and outdoor air temperatures (where $\alpha_p = 8.7 \text{ W/m}^2 \text{ K}$)

$$\Delta t \leq -260 \lg \varphi_p / k. \quad (7)$$

In order to calculate permissible air temperature according to equation (7) it is necessary to know the indoor air relative humidity. The relationship between indoor air relative humidity and outdoor air relative humidity is

$$\varphi_p = 8.93 + 0.815 \varphi_l, \quad R^2 = 0.65 \quad (8)$$

where

φ_p, φ_l - relative humidity of indoor and outdoor air, %.

The indoor air average relative humidity is about 5 % lower than that of outdoor air humidity. However in separate days the indoor air relative humidity was up to 10 % higher and up to 10 % lower than outdoor air humidity.

A cowshed must be ventilated so intensively as to maintain permissible temperature difference value. Ventilation intensity, G , kg/s

$$G = \frac{\sum Q_0}{c} \left(\frac{\varepsilon}{\Delta t} - x \right) = \rho v f, \quad (9)$$

where

$\sum Q_0$ - flow of the total heat of the cattle, kW;

c - specific heat capacity of the air, KJ/kg K;

ε - ratio of the sensible heat of the cattle and total heat;

x - modulus of the heat losses through the external barriers of the cowshed, 1/K

($x = 10^{-3} \sum kF / \sum Q_0$, where F - area of the external barrier, m^2);

ρ - density of the inside air, kg/m^3 ;

v - speed of the outlet air, m/s;

f - area of the air outlets opening, m^2 .

To check whether ventilation system of a cowshed is well fitted and exploited we compare the calculated (equation 7) temperature difference between indoor and outdoor air with the actual one. The latter must not be higher than the calculated one. Experimental tests were carried out in an uninsulated cowshed with 200 places, whose average heat transfer coefficient of external barriers was $4.5 \text{ W/m}^2 \text{ K}$, and heat losses module 0.06 1/K . Experimental data and calculation results are provided in Figure. The ventilation system maintained temperature difference, whose mean value was $\Delta t = 3.8 \pm 1.0$ ($p \leq 0.33$). The calculated temperature difference was $4 \text{ }^\circ\text{C}$, when the indoor air relative humidity was 5%

lower than that of outdoor air. Water vapour condensation on internal surface of external barriers was not observed. We can assert that the ventilation system was well fitted in and adequately exploited.

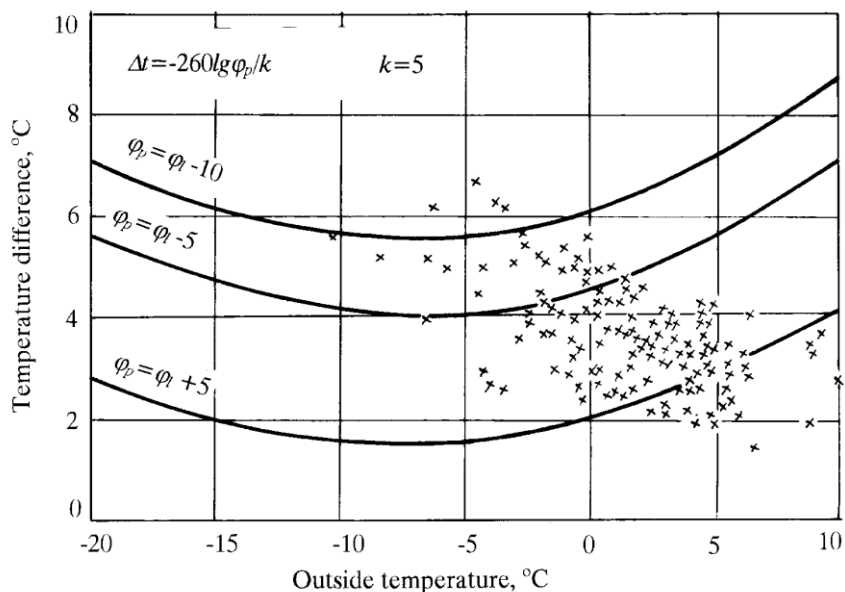

Figure. The dependence of indoor and outdoor air temperatures difference on the outdoor air temperature. Continuous line - analytical dependence, point - experimental dependence

Indoor air quality indicators and livestock housing conditions

In this chapter we present air quality parameters of a cubicle-type uninsulated cowshed and their comparison with those of an insulated cowshed.

Ammonia emission is an important indicator describing air quality and ecological state. Our experimental findings show that ammonia concentration and emission were as follows: in an uninsulated cowshed 3 ppm and 14 ± 3 g per day per animal place ($p < 0.33$), when the indoor air temperature is $t_p = 3$ °C; in an insulated cowshed 11 ppm and 20 ± 8 g per day per animal place ($p < 0.33$), when $t_p = 11$ °C. West European experimental evidence indicates (Amon et al. 1999) that 6-17 g of ammonia evaporates per day per animal place in a cowshed.

The air of an uninsulated cowshed is less contaminated by dust and microorganisms. Here dust concentration fluctuated from 1.51 to 2.58 mg/m^3 , and in an insulated cowshed from 2.56 to 4.75 mg/m^3 . Average dust content in the air in an insulated cowshed is by 2.06 mg/m^3 higher than that in an uninsulated shed ($0.01 < p < 0.001$). During the indoor period the concentration of microorganisms in an insulated cowshed was by on average $31 \cdot 10^6$ in m^3 higher than that in an uninsulated one ($0.05 < p < 0.001$). (Investigation of the Lithuanian Veterinary Academy).

Air quality parameters in a cold deep cowshed are going to be investigated in the future.

Tecnological and technical solutions of uninsulated cowsheds constructed in Lithuania meet major requirements of livestock welfare and are congruent with international trends. In summer animals graze in pastures.

CONCLUSIONS

1. Technological and technical solutions of uninsulated cowsheds built in Lithuania are analogous to those applied in West Europe.
2. Mathematical model of the parameter describing climatic conditions of an uninsulated cowshed and weeping of inner surface of barriers - the difference between indoor and outdoor temperatures, was elaborated (equation 7).
3. By analytical and experimental tests we determined that when selecting parameters of uninsulated cowsheds ventilation system, the calculated value of indoor and outdoor air temperatures differences is 4 °C, and the indoor air relative humidity is about 5 % lower than that of outdoor air.
4. Ammonia emission in wintertime in an uninsulated cubicle-type cowshed is 30 % lower than that in an insulated one and makes up 14 g per day per animal place.

We are planning to evaluate air quality parameters in a cold deep cowshed in the future.

REFERENCES

1. AMON B., AMON TH., BOXBERGER J.(1999). Emissions of NH₃, N₂O and CH₄ from milking cows housed in a farmyard manure tying stall (housing), manure storage, manure spreading. Proceedings of the International Conference "Trends in Agricultural Engineering" held in Prague on September 15-17, 1999. Czech University of Agriculture Prague, p.452-457.
2. BREHME U. Dairy cattle management in cold housing-experience gained on East German dairy farms. (1999). Proceedings of the International Conference "Trends in Agricultural Engineering" held in Prague (Czech Republic) on September 15-17, 1999. Czech University of Agriculture Prague, p. 346-353.
3. CARLSON G., SVENSSON L. (1994). Ammonia and dust emissions from animal housing and ammonia emissions from manure stores and land application. Animal waste management. ESCORENA, p.289-300.
4. EPINATJEFF P. (1997). Aussenkliämstalle für Milchvieh. Landtechnik, Jg.52, N 6, s.313-316.
5. PEDERSEN S. et al. (1998). A comparison of three balance methods for calculating ventilation rates in livestock buildings. J. agric. Engng Res., 70, p.25-37.
6. PÖLLINGER A. (1998). Besser mobil als stationär-Die mobile Entmistung im Rinderstall hilft Kosten sparen. DLZ Agrobonus, N 2., s.22-26.
7. SUHR A., JAHNKE D., MAIER P. (1999). Was kosten moderne Milchviehställe?. Neue Landworts,- Jg. 10, N 11, s. 76-80.